



## Second Revision No. 1-NFPA 750-2021 [ Sections 1.2.2, 1.2.3 ]

### 1.2.2

The purpose of this standard for low-rise occupancies ~~and~~ in accordance with 10.3.1 , and one- and two-family dwellings in accordance with 10.3.2 , shall be to provide the requirements for a water mist system that aids in the detection and control of residential fires and, thus, provides improved protection against injury, life loss, and property damage.

### 1.2.3

For low-rise occupancies in accordance with 10.3.1 , and one- and two-family dwellings in accordance with 10.3.2 , a water mist system shall be designed and installed in accordance with this standard to prevent flashover (total involvement) in the room of fire origin where water mist nozzles are installed, and to improve the ability of occupants to escape or be evacuated.

## Submitter Information Verification

**Committee:** WAM-AAA

**Submittal Date:** Wed Sep 22 15:22:05 EDT 2021

## Committee Statement

**Committee Statement:** Section updated to clarify that the scope defined in sections 1.2.2 and 1.2.3 are specific to the noted chapter 10 sections .

**Response Message:** SR-1-NFPA 750-2021

Public Comment No. 19-NFPA 750-2021 [Sections 1.2.2, 1.2.3]



## Second Revision No. 9-NFPA 750-2021 [ Section No. 2.4 ]

### 2.4 References for Extracts in Mandatory Sections.

NFPA 1, *Fire Code*, 2018 2021 edition.

NFPA 13, *Standard for the Installation of Sprinkler Systems*, 2022 edition.

NFPA 20, *Standard for the Installation of Stationary Pumps for Fire Protection*, 2019 2022 edition.

NFPA 25, *Standard for the Inspection, Testing, and Maintenance of Water-Based Fire Protection Systems*, 2017 2020 edition.

### Submitter Information Verification

**Committee:** WAM-AAA

**Submittal Date:** Fri Nov 05 15:15:19 EDT 2021

### Committee Statement

**Committee Statement:** Reference to NFPA 13, 2022 Edition has been restored as it's now referenced in chapter 5 of NFPA 750.

**Response Message:** SR-9-NFPA 750-2021



## Second Revision No. 2-NFPA 750-2021 [ New Section after 3.3.25.3 ]

### 3.3.25.2 Electronically-Operated Automatic Water Mist Nozzles.

Nozzles that are normally closed and operated by electrical energy that is initiated and supplied by fire detection and control equipment.

### Submitter Information Verification

**Committee:** WAM-AAA

**Submittal Date:** Wed Sep 22 15:28:03 EDT 2021

### Committee Statement

**Committee Statement:** Electronically Operated Automatic Water Mist Nozzles do exist in the industry therefore a definition was added to recognize this new technology. There is no prerequisite for a product to be listed/approved before being referenced in an NFPA code or standard. The requirements clearly recognize new and developing technology but do not allow the use without a listing.

**Response Message:** SR-2-NFPA 750-2021

Public Comment No. 15-NFPA 750-2021 [New Section after 3.3.25.3]



## Second Revision No. 7-NFPA 750-2021 [ Sections 5.1.1, 5.1.2, 5.1.3 ]

### 5.1.1\* Light Hazard Occupancies.

Light hazard occupancies shall be defined as occupancies or portions of other occupancies where the quantity and/or combustibility of contents is low and fires with relatively low rates of heat release are expected.

#### A.5.1.1

Light hazard occupancies include occupancies having uses and conditions similar to the following:

- (1) Animal shelters
- (2) Churches
- (3) Clubs
- (4) Eaves and overhangs, if of combustible construction with no combustibles beneath
- (5) Educational
- (6) Hospitals, including animal hospitals and veterinary facilities
- (7) Institutional
- (8) Kennels
- (9) Libraries, except large stack rooms
- (10) Museums
- (11) Nursing or convalescent homes
- (12) Offices, including data processing
- (13) Residential
- (14) Restaurant seating areas
- (15) Theaters and auditoriums, excluding stages and prosceniums
- (16) Unused attics

Note that it is not the committee's intent to automatically equate library bookshelves with ordinary hazard occupancies or with library stacks. Typical library bookshelves of approximately 2.4 m (8 ft) in height, containing books stored vertically on end, held in place in close association with each other, with aisles wider than ~~762~~ 750 mm (30 in.) can be considered to be light hazard occupancies. Similarly, library stack areas, which are more akin to shelf storage or record storage, as defined in NFPA 232, should be considered to be ordinary hazard occupancies. [13:A.4.3.2]

### 5.1.2\* Ordinary Hazard (Group 1) (OH1).

Ordinary hazard (Group 1) occupancies shall be defined as occupancies or portions of other occupancies where ~~the quantity and combustibility of the contents do not exceed the amount of miscellaneous storage of Class 2, 3, 4, plastics, tires, and roll paper provided in Table 4.3.1.7.1.1 of NFPA 13~~ combustibility is low, quantity of combustibles is moderate, stockpiles of contents does not exceed 2.4 m (8 ft), and fires with moderate rates of heat release are expected.

### 5.1.3\* Ordinary Hazard (Group 2) (OH2).

Ordinary hazard (Group 2) occupancies shall be defined as occupancies or portions of other occupancies where the quantity and combustibility of contents are moderate to high, stockpiles of contents with moderate rates of heat release do not exceed ~~3.66~~ 3.7 m (12 ft), and stockpiles of contents with high rates of heat release do not exceed 2.4 m (8 ft).

**A.5.1.3**

Ordinary hazard (Group 2) occupancies include occupancies having uses and conditions similar to the following:

- (1) Agricultural facilities
- (2) Automobile parking garages
- (3) Barns and stables
- (4) Cereal mills
- (5) Chemical plants — ordinary
- (6) Confectionery products
- (7) Distilleries
- (8) Dry cleaners
- (9) Exterior loading docks (Note that exterior loading docks only used for loading and unloading of ordinary combustibles should be classified as OH2. For the handling of flammable and combustible liquids, or hazardous materials, or where utilized for storage, exterior loading docks and all interior loading docks should be protected based upon the actual occupancy and the materials handled on the dock, as if the materials were actually stored in that configuration.)
- (10) Feed mills
- (11) Horse stables
- (12) Leather goods manufacturing
- (13) Libraries — large stack room areas
- (14) Machine shops
- (15) Metal working
- (16) Mercantile
- (17) Paper and pulp mills
- (18) Paper process plants
- (19) Piers and wharves
- (20) Plastics fabrication, including blow molding, extruding, and machining; excluding operations using combustible hydraulic fluids
- (21) Post offices
- (22) Printing and publishing
- (23) Racetrack stable/kennel areas, including those stable/kennel areas, barns, and associated buildings at state, county, and local fairgrounds
- (24) Repair garages
- (25) Resin application areas
- (26) Stages
- (27) Textile manufacturing
- (28) Tire manufacturing
- (29) Tobacco products manufacturing
- (30) Wood machining
- (31) Wood product assembly

[13:A.4.3.3.2]

## Submitter Information Verification

**Committee:** WAM-AAA

**Submittal Date:** Wed Sep 22 15:42:52 EDT 2021

## Committee Statement

**Committee Statement:** The definitions of LH, OH1, and OH2 in the main body are extracted from NFPA 13 (2022 Edition) since the annex text for these definitions are already indicated as being extracted from NFPA 13. This update provides consistency between the two documents. This approach is consistent with the 2015 edition of NFPA 750.

The NFPA 750 extracted annex sections are updated as per the updates in annex sections of the 2022 Edition of NFPA 13.

**Response Message:** SR-7-NFPA 750-2021

[Public Comment No. 14-NFPA 750-2021 \[Section No. 5.1.2\]](#)



## Second Revision No. 6-NFPA 750-2021 [ Section No. 6.9.1.8 ]

### 6.9.1.8 Unloader Valves.

Unloader: Where provided, unloader valves shall be part of a listed pump assembly or be listed separately.

### Submitter Information Verification

**Committee:** WAM-AAA

**Submittal Date:** Wed Sep 22 15:38:42 EDT 2021

### Committee Statement

**Committee Statement:** The change clarifies that unloader valve is not required to be provided.

**Response Message:** SR-6-NFPA 750-2021

[Public Comment No. 5-NFPA 750-2021 \[Global Input\]](#)



## Second Revision No. 3-NFPA 750-2021 [ Section No. 7.3 ]

### 7.3 Nozzle Types.

Water mist nozzles shall be classified as one of the following ~~three~~ four types:

- (1) Automatic
- (2) Nonautomatic
- (3) Multifunctional
- (4) Electronically-operated automatic

### Submitter Information Verification

**Committee:** WAM-AAA

**Submittal Date:** Wed Sep 22 15:31:05 EDT 2021

### Committee Statement

**Committee Statement:** Recognition is warranted based on inclusion of the definition of electronically operated automatic water mist nozzle. Committee corrected name for consistency.

**Response Message:** SR-3-NFPA 750-2021

[Public Comment No. 18-NFPA 750-2021 \[Section No. 7.3\]](#)



## Second Revision No. 4-NFPA 750-2021 [ Section No. A.4.1 ]

### A.4.1

A water mist system is a water-based fire protection system using that uses very fine water sprays (i.e., water mist). The very small water droplets allow the water mist to control or extinguish fires by cooling of the flames and fire plumes, displacing oxygen displacement by water with water vapor, attenuating radiant heat attenuation, and prevention of fire, and preventing fire spread by pre-wetting of combustibles.

Water mist systems have proved effective in controlling, suppressing, or extinguishing many types of fires. Potential applications include the following:

- (1) Gas jet fires
- (2) Flammable and combustible liquids, including storage
- (3) Hazardous solids, including fires involving plastic foam furnishings
- (4) Protection of aircraft occupants from an external pool fire long enough to provide time to escape
- (5) Ordinary (Class A) combustible fires such as paper, wood, and textiles
- (6) Occupancy classifications in accordance with Chapter 5
- (7) Electrical hazards, such as transformers, switches, circuit breakers, rotating equipment, and cable tunnels
- (8) Electronic equipment, including telecommunications equipment
- (9) Highway and railway tunnels (*see NFPA 502*)  
Fighter aircraft hangars, light aircraft hangars, and helicopter hangars

### Submitter Information Verification

**Committee:** WAM-AAA

**Submittal Date:** Wed Sep 22 15:33:22 EDT 2021

### Committee Statement

**Committee Statement:** Aircraft hangar applications are removed as there are no references to Recognized Testing Laboratory fire testing protocols that evaluate water mist fire protection performance in aircraft hangar applications. NFPA 409 does not have any requirements for the protection of hangars using water mist systems.

**Response Message:** SR-4-NFPA 750-2021

Public Comment No. 1-NFPA 750-2021 [Section No. A.4.1]



**Second Revision No. 8-NFPA 750-2021 [ Section No. A.13.1.6 ]**



**A.13.1.6**

See Figure A.13.1.6(a) through Figure A.13.1.6(l).

**Figure A.13.1.6(a) Schematic Representation of a High Pressure, Gas-Driven System with Stored Water (Pre-Engineered System). [Typical]**

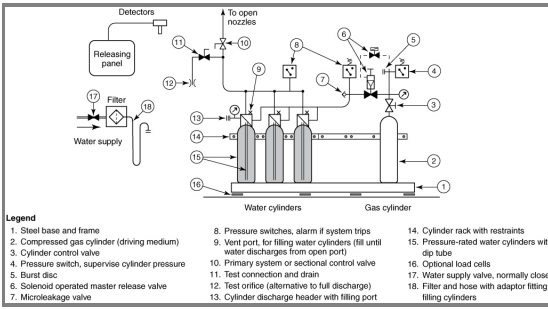

**Figure A.13.1.6(b) Schematic Representation of a High Pressure, Gas-Driven System with Multiple Accumulator Units for Extended Duration. [Typical]**

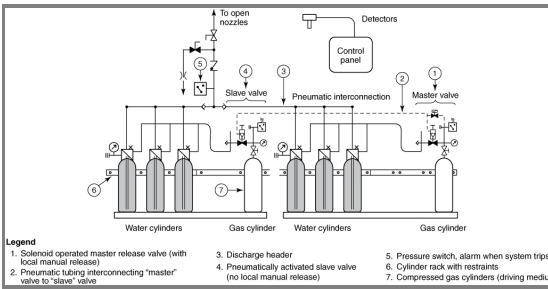

**Figure A.13.1.6(c) Schematic Representation of a Low-Pressure Twin-Fluid Water Mist System. [Typical]**

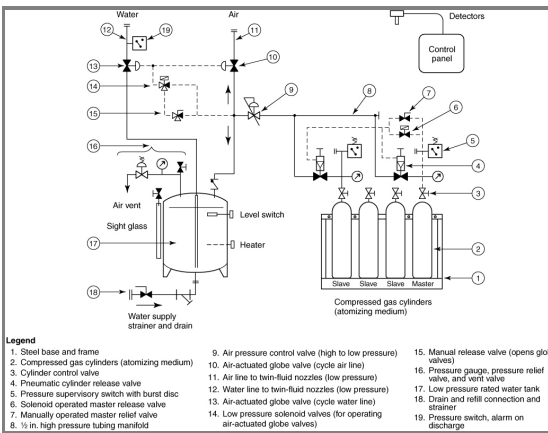

**Figure A.13.1.6(d) Schematic Representation of a Single-Fluid Water Mist System. [Typical]**

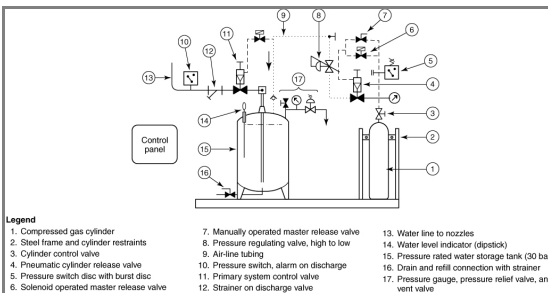

**Figure A.13.1.6(e) Schematic Diagram of a Pump-Driven Water Mist System. [Typical]**

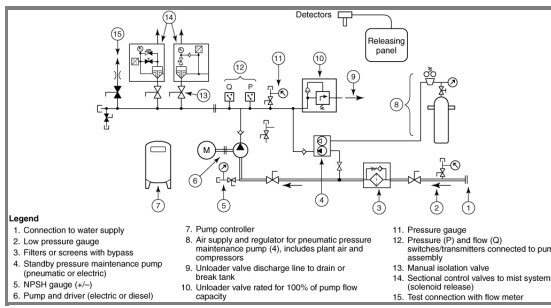

**Figure A.13.1.6(f) Schematic Representation of a Positive Displacement Pump Assembly with Unloader Valves on Each Pump and Pressure Relief Valve on Discharge Manifold. [Typical]**

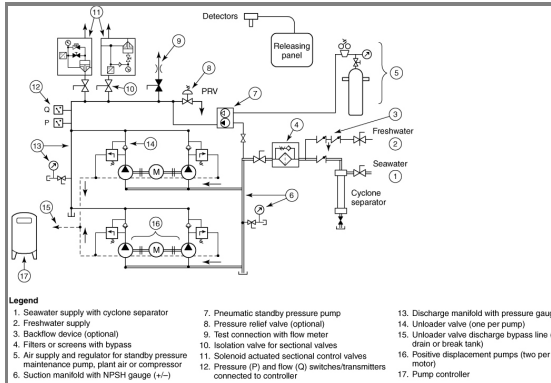

**Figure A.13.1.6(g) Schematic Representation of a Positive Displacement Pump Assembly with Pressure Relief Valve on Discharge Manifold. [Typical]**

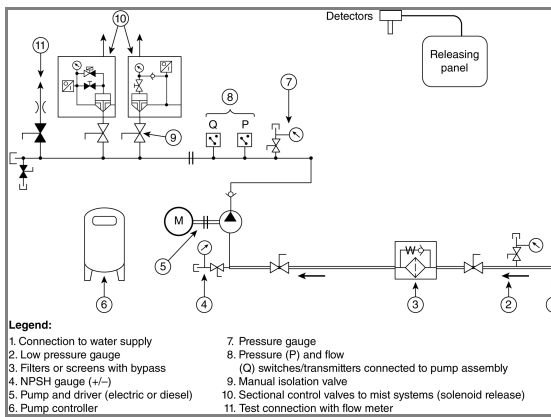

**Figure A.13.1.6(h) Schematic Diagram of a "Break Tank" Connection in Supply to Positive Displacement Pumps (Marine Systems). [Typical]**

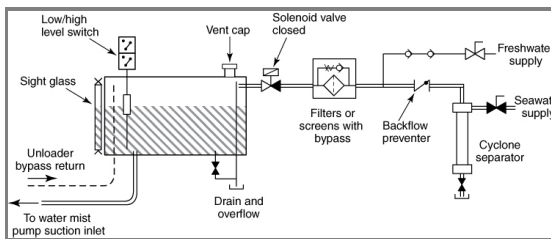

**Figure A.13.1.6(i) Gas Pump Unit for Machinery Spaces and Gas Turbine Enclosures. [Typical]**

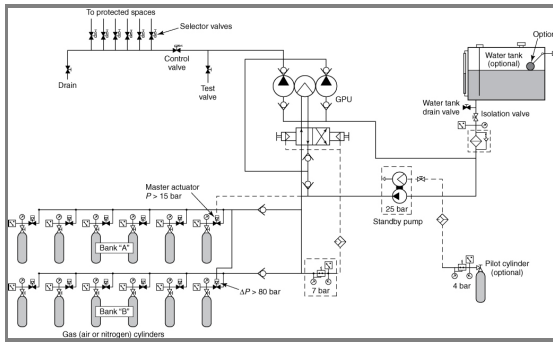

Figure A.13.1.6(j) Gas Pump for Light Hazard Applications. [Typical]

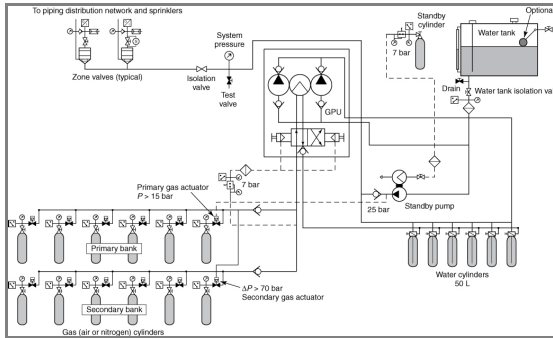

Figure A.13.1.6(k) Example of a Piping Arrangement with Fire Department Connection for Intermediate or High Pressure Water Mist Systems with Positive Displacement Pump or Pump Assembly.

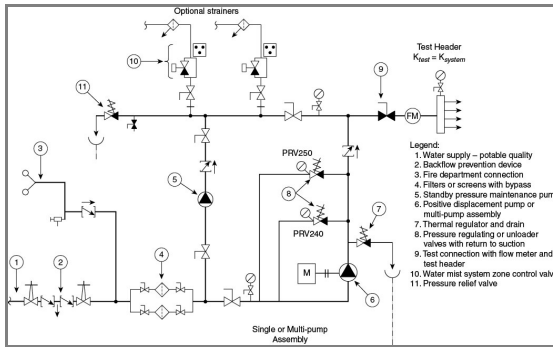
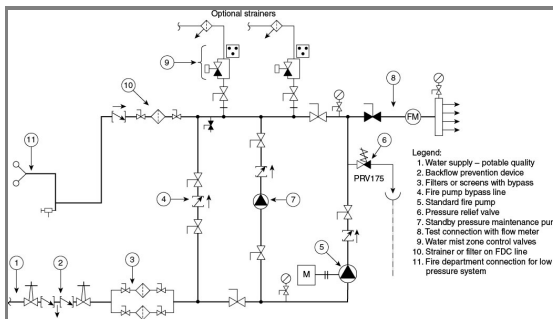

Figure A.13.1.6(l) Example of a Piping Arrangement with Fire Department Connection for Low- Pressure Water Mist Systems.



Supplemental Information

File Name	Description	Approved
NEW_Figure_A.13.1.6_g_.jpg	For Editorial	

## Submitter Information Verification

**Committee:** WAM-AAA

**Submittal Date:** Tue Oct 12 17:10:10 EDT 2021

## Committee Statement

**Committee Statement:** New diagram is added to illustrate a water mist system that does not include an unloader valve since an unloader valve is not required in all systems.

**Response Message:** SR-8-NFPA 750-2021

[Public Comment No. 13-NFPA 750-2021 \[Global Input\]](#)



## Second Revision No. 10-NFPA 750-2021 [ Section No. E.3 ]

### E.3 References for Extracts in Informational Sections.

NFPA 13, *Standard for the Installation of Sprinkler Systems*, ~~2019~~ 2022 edition.

NFPA 20, *Standard for the Installation of Stationary Pumps for Fire Protection*, 2022 edition

### Submitter Information Verification

**Committee:** WAM-AAA

**Submittal Date:** Fri Nov 05 16:21:42 EDT 2021

### Committee Statement

**Committee Statement:** Adding NFPA 20 to reference list for extracts as it is now extracted in Annex A.

**Response Message:** SR-10-NFPA 750-2021