



Public Input No. 1624-NFPA 70-2023 [Global Input]

NOTE: This public input originates from Tentative Interim Amendment No. 23-9 (Log 1687) issued by the Standards Council on March 21, 2023 and per the NFPA Regs., needs to be reconsidered by the Code-Making Panel for the next edition of the Document.

See attached TIA 23-9 (Log 1687) for revisions to the definition of "Pool" and to revise Section 680.26.

Additional Proposed Changes

<u>File Name</u>	<u>Description</u>	<u>Approved</u>
TIA_1687_70_23_9.pdf	NEC TIA 23-9 Log 1687	

Statement of Problem and Substantiation for Public Input

NOTE: This public input originates from Tentative Interim Amendment No. 23-9 (Log 1687) issued by the Standards Council on March 21, 2023 and per the NFPA Regs., needs to be reconsidered by the Code-Making Panel for the next edition of the Document.

Substantiation: This Tentative Interim Amendment (TIA) is proposed by a Task Group appointed by NFPA staff pursuant to the decision of the Standards Council D#22-3 on Agenda item SC#22-8-5-w-1 as voted 12 August 2022. This decision denied the underlying appeal, but found that issues raised at the hearing relative to current research and loss experience required "timely analysis." Given the "highly technical nature" of the subject matter, the Council directed that this Task Group be one that was "balanced" and that possessed the technical expertise to evaluate the relevant research. As there is considerable controversy over this issue, the focus was reaching common ground which would result in a practical compromise acceptable to the participants.

The Task Group focused its attention on 680.26(B)(2) which covers the bonding of the surfaces that make up the perimeter of a swimming pool. After extensive discussion, the Task Group is proposing a complete rewrite of this material, as well as related material within the scope of CMP 17. The detailed substantiation follows:

The Task Group considered action by inspectors in some jurisdictions that consider large bodies of water with limited beaches, many acres in size, as pools because they are used for swimming. In such instances, the perimeter bonding requirements have resulted in requirements to bury bare solid 8 AWG around the entire perimeter of such bodies of water. These applications are clearly covered in Article 682, and the revised text makes that clear.

The Task Group is also suggesting new Informational Notes in 680.26(A) that address general performance issues. The Task Group emphasizes that the potential hazard in these areas results from voltage gradients in the earth that can pose unique hazards to persons entering or exiting a swimming pool or to persons simultaneously in contact with the perimeter surface and the pool water, because wet skin has substantially decreased resistance to electric current.

The Task Group is aware that these gradients can originate on either side of the service point, including on the utility side of that point. A new informational note points to the lack of jurisdiction of the NEC in such cases, and identifies the NESC provisions that can allow for reduction or elimination of such gradients from that source. A second informational note points to the effects that corrosive environments can have on electrical components, including bonding connections.

The remainder of the TIA addresses 680.26(B)(2) on "Perimeter Surfaces." This location was the focus of the Standards Council appeal, and it involved the most extensive discussions. The mandatory horizontal reach of these requirements, 900mm (3 ft), is unchanged. The task group

discussed at length increasing this distance to 5 ft , and decided against changing the mandatory limit; however, the task group did agree to change the wording to “not less than” to emphasize that the distance specified is not an upper limit, only the lower limit. It is important to recognize that any horizontal measurement extends an island of stable voltage in a potential sea of gradients. Addressing these could logically require extending the size of the island to encompass the entire parcel of land, and that clearly would be impractical. The 3-ft parameter addresses the enhanced exposure presented to swimmers entering or exiting a pool or to persons simultaneously in contact with the perimeter surface and the pool water.

There is also a height parameter added that limits the reach to surfaces within 900mm (3 ft) above the maximum water level and not over 600 mm (2 ft) below this level. The vertical limit excludes surfaces that are out of reach of a swimmer (3 ft vertical reach from within the pool, or what would end up being a reach across a pool wall and then 2 ft down to grade) and also excludes aboveground pools that do not present a walk-off exposure. These were also excluded in the public comment that put the appeal in motion. The 2 ft measurement also prevents someone from making the distinction with a pool that is really an inground pool with a minor upward extension from grade.

Nonconductive pool shells continue to omit the four-corner bonding connection rule as such connections are impossible. However, there will be other more enhanced requirements in place. Any perimeter surfaces that are included elsewhere in a bonding requirement must meet that requirement, with the bonding to include a connection to an 8 AWG solid conductor that will also make a connection to the water and any other bonded surfaces. It will also be connected to any conductive support structure for the pool. The surrounding perimeter surfaces incorporate a bonding requirement, and the wording here assures that such bonding includes other relevant parts of the pool and the immediately surrounding perimeter locations.

A new informational note follows at this point that describes the principal remaining utility of the single wire bonding connection, and that is to interconnect noncontiguous portions of a pool that has stranded perimeter surfaces with intervening spaces that do not present an exposure hazard from voltage gradients. A good example would be a pool with one wall that is on the edge of a steep incline, one that precludes any entrance or exit from the pool from that side. The remainder of the section is completely rewritten with four third level subdivisions [(a), (b), (c), and (d)]. The first [(a)] one covers conductive paved portions of perimeter surfaces. The word “conductive” in this case correlates with the use of equivalent terminology in 680.26(B)(1), and thereby includes cast-in-place concrete, pneumatically applied or sprayed concrete, and concrete block with painted or plastered coatings, and it recognizes the increased conductivity resulting the proximity of water and the resulting permeability and porosity. The topic sentence also expressly includes masonry pavers in this category.

The language includes prescriptive requirements on the reinforcing used in these surfaces, which where used must comply with equivalent reinforcing applications for the pool itself in 680.26(B)(1)(a), or apply welded wire mesh. The mesh must be chaired up so as to be completely embedded within the concrete placement. The text does allow for the use of fiber reinforcement which precludes embedded conductive reinforcement. In such cases the grid must be positioned below the concrete, but no more than 6 in. below finished grade. The “finished grade” parameter was supposed to have been included in the 2023 NEC, but its inclusion was a casualty of the Standards Council action to revert to previous edition text; it is now being restored. A new informational note follows, explaining the effects of locating the bonding elements as close to the surface as possible.

Also included are requirements for grids for equipotential bonding. Steel and copper show up together, now with the same requirements, and the grade reference is corrected from the former “subgrade” to the intended “finished grade” The equivalence between steel and copper is intended, because a new requirement is added for a listing on this equipment with an appropriate delayed effective date. The listing requirement would not apply to fully embedded steel reinforcing because it is already subject to testing and identification under applicable standards which address corrosion and mechanical performance, including for full embedding in concrete, and because years of experience has shown that where fully embedded, traditional reinforcing members which meet the applicable standards retain their integrity. A new informational note here provides comprehensive background information on ASTM recognized classifications for reinforcing steel as could be applied (contingent on a listing) in these applications.

The next third level subdivision [(b)] covers unpaved perimeter surfaces, leading off, in (1), with the single bare 8 AWG conductor. The first five list items are unchanged from the 2023 NEC, and are not in themselves controversial. Regarding the sixth list item, the Task Group did not reach any specific conclusion as to the comparative effectiveness of various bonding approaches. As a compromise, the single wire is now to be allowed only under perimeter surfaces that do not

have “direct access to swimmers in the pool.” Any other perimeter surface required to be bonded must now employ a grid bonding approach. Note that this phrasing carefully avoided the use of related terms including “accessible” as covered in Art. 100; this usage generally correlates with the limitations of these requirements to areas involved in the exposure of swimmers to voltage gradients.

The other major topic here, in (2), covers the use of grids for equipotential bonding. Steel and copper show up together, now with the same requirements as for paved surfaces, and here again, the grade reference is corrected from the former “subgrade” to the intended “finished grade” The next third level subdivision [(c)] covers a common-sense exemption from bonding to surfaces that are nonconductive, and as such are inherently excluded from the potential propagation of voltage gradients. This includes any perimeter surfaces that are electrically separated from the pool structure and raised on nonconductive supports above a bonded surface. For example, this latter type of construction is sometimes used for (but not limited to) pools on and in buildings where the surrounding floor is inherently and securely bonded due to the concrete reinforcement, but there is a walking surface consisting of individual tiles or nonconductive boards, separated from each other and from the pool structure, and raised above the bonded floor on insulated risers. Such an arrangement isolates the user of the perimeter surface from whatever might exist in terms of voltage gradients.

The final third level subdivision [(d)] requires the interconnection of all bonded portions of perimeter surfaces. If this were not so, the voltage on one part of the perimeter could differ from another part. This in turn could allow a dangerous potential difference to exist between adjacent parts of the perimeter, and thereby undermine the objectives of the other rules.

Emergency Nature: The proposed TIA intends to offer to the public a benefit that would lessen a recognized (known) hazard or ameliorate a continuing dangerous condition or situation.

As set forth in the underlying appeal that prompted the Standards Council to decree prompt action on this matter, this TIA, in accordance with 5.4(d) of the Regulations, will “offer to the public a benefit that would lessen a recognized hazard and ameliorate a continuing dangerous condition or situation.” Indeed, the urgency of this matter informed the Council decision that also required the Task Group to come to a conclusion and report by November 30, 2022 so the Council could take action at its very next meeting in December. This TIA will make these benefits generally available upon issuance and enforceable as soon as possible.

Submitter Information Verification

Submitter Full Name: CMP on NEC-P17

Organization: Code-Making Panel 17

Street Address:

City:

State:

Zip:

Submittal Date: Thu Jul 27 14:09:47 EDT 2023

Committee: NEC-P17

Committee Statement

Resolution: [FR-9239-NFPA 70-2024](#)

Statement: Revisions to this section include:

Informational Note 1 to 680.26(A) was revised to comply with 2.1.10 of the NEC Style Manual.

Informational Note 2 to 680.26(A) was deleted as it did not add clarity to the requirements. Corrosive environments are already addressed in 680.14, and performance requirements are already addressed in 680.26(A). Therefore, this language is not needed.

Section 680.26(B) was editorially revised into a list format for ease of reading, in

accordance with 3.5.2 of the NEC Style Manual. New text was added to clarify that structural reinforcing steel and steel structural welded wire reinforcement are permitted options for bonding. These options were inferred but not explicitly stated.

Section 680.26(B) was revised by changing “panelboard” to “panelboard enclosure” for accuracy.

Multiple editorial changes were made to 680.26(B)(2) for clarification and readability; and redundant language, including 680.26(B)(2)(d), was eliminated. The word “conductor” was added to the phrase “copper grid” in multiple locations for consistency, as was adding the word “structural” to the phrase “reinforcing steel.”

An allowance for a copper conductor grid was added in 680.26(B)(2)(a)(2) because a copper conductor grid should be a permitted method of achieving the bonding contemplated in this section.



Tentative Interim Amendment

NFPA[®] 70[®]

National Electrical Code[®]

2023 Edition

Reference: Definition of Pool, and 680.26

TIA 23-9

(SC 23-3-8 / TIA Log #1687)

Pursuant to Section 5 of the NFPA *Regulations Governing the Development of NFPA Standards*, the National Fire Protection Association has issued the following Tentative Interim Amendment to NFPA 70[®], *National Electrical Code[®]*, 2023 edition. The TIA was processed by the NEC Code-Making Panel 17 and the NEC Correlating Committee, and was issued by the Standards Council on March 21, 2023, with an effective date of April 10, 2023.

1. *Revise the definition of “Pool” to read as follows:*

Pool. Manufactured or field-constructed equipment designed to contain water on a permanent or semipermanent basis and used by persons for swimming, wading, immersion, or therapeutic purposes, but not including bodies of water incorporated as part of an industrial process or lakes, lagoons, surf parks, or other natural and man-made bodies of water that may incorporate swimming and swimming areas. (680) (CMP-17)

Informational Note: Natural and man-made bodies of water, which includes lakes, lagoons, surf parks, or other similar bodies of water, are addressed in Article 682.

2. *Revise section paragraph 680.26 to read as follows:*

680.26 Equipotential Bonding.

(A) Performance. The equipotential bonding required by 680.26(B) and (C) to reduce voltage gradients in the pool area shall be installed for pools with or without associated electrical equipment related to the pool.

Informational Note No. 1: Some causes of voltage gradients originate outside the premises wiring system and are not within the scope of the NEC. Measures identified in Rule 097D2 of ANSI C2, *National Electrical Safety Code*, can also serve to address voltage gradients originating on the utility side of the service point.

Informational Note No. 2: By its nature, equipotential bonding of swimming pools and perimeter surfaces involves contact between various metallic materials and the earth. This can, in some cases, expose various specific metals to a corrosive environment, depending on factors such as the type and chemical content of the soil and the specific metal. Corrosive environments are also addressed in 680.14.

(B) Bonded Parts. ...

(1) Conductive Pool Shells. ...

(2) Perimeter Surfaces. The perimeter surface to be bonded shall be considered to extend for ~~4 m~~ 900 mm (3 ft) horizontally beyond the inside walls of the pool ~~and~~ while also at a height between 900 mm (3 ft) above and 600 mm (2 ft) below the maximum water level. The perimeter surface shall include unpaved surfaces, concrete, and other types of paving. Perimeter surfaces separated from the pool by a permanent wall or building 1.5 m (5 ft) in height or more shall

require equipotential bonding only on the pool side of the permanent wall or building. Bonding to perimeter surfaces shall be provided as specified in 680.26(B)(2)(a), (B)(2)(b), ~~or (B)(2)(c), and (B)(2)(d).~~ and For conductive pool shells where bonding to perimeter surfaces is required, it shall be attached to the pool reinforcing steel or copper conductor grid at a minimum of four points uniformly spaced around the perimeter of the pool, or if the bonded perimeter surface does not surround the entire pool, it shall be attached to the pool reinforcing steel or copper conductor grid at a minimum of four uniformly spaced points along the bonded perimeter surface. For nonconductive pool shells where bonding to the perimeter surfaces is required, bonding at four points shall not be required, and the perimeter bonding shall be attached to the 8 AWG copper equipotential bonding conductor and, if present, to any conductive support structure for the pool.

Informational Note: Because the perimeter surface can incorporate various types of materials at various locations and elevations above and below maximum water level, the perimeter surface required to be bonded might not surround the entire pool. The 8 AWG copper equipotential bonding conductor can encircle the entire pool to facilitate connection of bonded parts.

(a) *Structural Reinforcing Steel.* Structural reinforcing steel shall be bonded in accordance with 680.26(B)(1)(a). *Conductive Paved Portions of Perimeter Surfaces.* Conductive paved portions of perimeter surfaces, including masonry pavers, if used, shall be bonded with unencapsulated structural reinforcing steel in accordance with 680.26(B)(1)(a), or with unencapsulated steel structural welded wire reinforcement (welded wire mesh, welded wire fabric), bonded together by steel tie wires or the equivalent. Steel welded wire reinforcement shall be fully embedded within the pavement unless the pavement will not allow for embedding. If the reinforcing steel is absent, or is encapsulated in a nonconductive compound, or embedding is not possible, unencapsulated welded wire steel reinforcement or a copper conductor grid shall be provided and shall be secured directly under the paving, and not more than 150 mm (6 in.) below finished grade.

Unencapsulated steel welded wire reinforcement that is not fully embedded in concrete, and copper grid regardless of location, where used for equipotential bonding, shall be listed for corrosion resistance and mechanical performance. This listing requirement shall become effective January 1, 2025. The copper grid or unencapsulated steel welded wire reinforcement shall also meet the following:

- (1) Copper grid is constructed of 8 AWG solid bare copper and arranged in accordance with 680.26(B)(1)(b)(3).
- (2) Steel welded wire reinforcement is minimum ASTM 6x6-W2.0 x W2.0 or minimum No. 3 rebar constructed in a 300 mm (12 in.) grid.
- (3) Copper grid and steel welded wire reinforcement follow the contour of the perimeter surface extending not less than 900 mm (3 ft) horizontally beyond the inside walls of the pool.
- (4) Only listed splicing devices or exothermic welding are used.

Informational Note No. 1: Performance of the equipotential bonding system at the perimeter surface is improved as the distance between the bonding means and finished grade is minimized, either by embedding within, or by direct contact with the underside of, the finished pavement.

Informational Note No. 2: See ASTM A615/A615M, *Standard Specification for Deformed and Plain Carbon-Steel Bars for Concrete Reinforcement*; A1064/A1064M, *Standard Specification for Carbon-Steel Wire and Welded Wire Reinforcement, Plain and Deformed, for Concrete*; A1022/A1022M, *Standard Specification for Deformed and Plain Stainless Steel Wire and Welded Wire for Concrete Reinforcement*; A1060A/A1060M, *Standard Specification for Zinc-Coated (Galvanized) Steel Welded Wire Reinforcement, Plain and Deformed, for Concrete*; and ACI Standard ACI 318, *Building Code Requirements for Structural Concrete*, for examples of standards currently used in the listing of reinforcing steel bars and steel welded wire reinforcement.

(b) *Unpaved Portions of Perimeter Surfaces.* Unpaved portions of perimeter surfaces shall be bonded with any of the following methods:

(1) *Copper Ring.* Where structural reinforcing steel is not available or is encapsulated in a nonconductive compound, a copper conductor(s) shall be utilized where the following requirements are met-meet the following:

(1)a. At least one minimum 8 AWG bare solid copper conductor, including the 8 AWG copper equipotential bonding conductor if available shall be provided.

(2)b. The conductors shall follow the contour of the perimeter surface.

(3)c. Only listed splicing devices or exothermic welding are used. shall be permitted.

(4)d. The required conductor(s) is shall be 450 mm to 600 mm (18 in. to 24 in.) from the inside walls of the pool.

(5)e. The required conductor(s) shall be secured within or is under the unpaved portion of the perimeter surface 100 mm to 150 mm (4 in. to 6 in.) below the subgrade finished grade.

f. Be installed only in perimeter surfaces not intended to have direct access to swimmers in the pool.

~~(e2) Copper Grid. Where structural reinforcing steel is not available or is encapsulated in a nonconductive compound, eCopper grid or unencapsulated steel welded wire reinforcement used for equipotential bonding of unpaved portions of perimeter surfaces shall be utilized where the following requirements are met meet the following:~~

~~(1)a. The copper grid shall be constructed of 8 AG solid bare copper and be arranged-Be installed in accordance with 680.26(B)(1)(b)(3)(B)(2)(a).~~

~~(2) The copper grid shall follow the contour of the perimeter surface extending 1 m (3 ft) horizontally beyond the inside walls of the pool.~~

~~(3) Only listed splicing devices or exothermic welding shall be permitted.~~

~~(4)b. The copper grid shall be secured-Be located within or under the deck or unpaved surface(s) between 100 mm to 150 mm (4 in. to 6 in.) below the subgradefinished grade.~~

(c) Nonconductive Perimeter Surfaces. Equipotential bonding shall not be required for nonconductive portions of perimeter surfaces that are separated from earth or raised on nonconducting supports, and it shall not be required for any perimeter surface that is electrically separated from the pool structure and raised on nonconductive supports above an equipotentially bonded surface.

Informational Note: Nonconductive materials include, but are not limited to, wood, plastic, wood-plastic composites, fiberglass, and fiberglass composites.

(d) Interconnection of Bonded Portions of Perimeter Surfaces. All surfaces where equipotential bonding is required shall be interconnected using listed splicing devices or exothermic welding. Where copper wire is used for this purpose, it shall be solid copper, not smaller than 8 AWG. The conductor shall be permitted to encircle the pool to facilitate bonding connections to portions of the perimeter covered in 680.26(B)(2)(a) and (B)(2)(b) that are not contiguous.

Issue Date: March 21, 2023

Effective Date: April 10, 2023

(Note: For further information on NFPA Codes and Standards, please see www.nfpa.org/docinfo)

Copyright © 2023 All Rights Reserved
NATIONAL FIRE PROTECTION ASSOCIATION



Public Input No. 4233-NFPA 70-2023 [Definition: Appliance.]

Appliance.

Utilization equipment, generally other than industrial, that is fastened in place, fixed, stationary, or portable; is normally built in a standardized size or type; and is installed or connected as a unit to perform one or more functions such as clothes washing, air-conditioning, food mixing, deep frying, and so forth. (CMP-17)

Statement of Problem and Substantiation for Public Input

According to the current definition, an “Appliance” is utilization equipment, generally other than industrial, that is fastened in place, stationary, or portable... What about “Fixed”? Section 210.8(B)(7) was expanded in 2023 to address cord-and-plug-connected fixed or stationary appliances located within 6 feet of a sink.

UL 197 is the Standard for Commercial Electric Cooking Appliances and has several definitions pertaining to appliances in Section 2 including:

2.3 Appliance

2.4 Automatically Controlled Appliance

2.12 Equipment-Fixed

2.12 Equipment-Portable

According to UL 197, a Fixed appliance is “An appliance that is intended to be fastened in place or located in a dedicated space and is permanently wired to the branch circuit”.

In the 2023 NEC, the terms “fixed appliance” and “portable appliance” from Article 550 were merged with the Article 100 definition of “appliance” with the intent to make one definition of an appliance that incorporates everything. Unfortunately, this one definition doesn’t include the word “fixed” and doesn’t quite align with the appliance definitions provided in product safety standards, or mention how the appliance types are connected to power.

Since the current definition of “Fixed” only applies to Article 680 applications, I am submitting a related Public Input to delete the reference to Article (680) from the definition.

Related Public Inputs for This Document

<u>Related Input</u>	<u>Relationship</u>
<u>Public Input No. 4229-NFPA 70-2023 [Definition: Fixed (as applied to equipment).]</u>	

Submitter Information Verification

Submitter Full Name: Jeffrey Simpson

Organization: ElectricalLicenseRenewal.com

Street Address:

City:

State:

Zip:

Submittal Date: Thu Sep 07 02:26:24 EDT 2023

Committee: NEC-P17

Committee Statement

Resolution: [FR-8854-NFPA 70-2024](#)

Statement: The existing list items were removed to improve clarity as they could be viewed as all-inclusive and unintentionally omit other types of appliances.



Public Input No. 2350-NFPA 70-2023 [Definition: Fixed (as applied to equipment).]

Fixed (as applied to equipment).

Equipment that is fastened or otherwise secured at a specific location. (680)-(CMP-47 1)

Statement of Problem and Substantiation for Public Input

The term 'fixed' is used 266 times in the Code. This definition is a very common word that should apply in general and not just to Article 680 requirements. This definition should also fall under the purview of CMP-1. The proposed revisions will enhance usability throughout the NEC.

Submitter Information Verification

Submitter Full Name: Mike Holt
Organization: Mike Holt Enterprises Inc
Street Address:
City:
State:
Zip:
Submittal Date: Wed Aug 16 14:08:17 EDT 2023
Committee: NEC-P17

Committee Statement

Resolution: [FR-9009-NFPA 70-2024](#)

Statement: The term "Fixed" is used in articles beyond Article 680, but still relates to CMP17 for many of its uses, therefore should remain under purview of CMP17, and not change to CMP 1.



Public Input No. 4229-NFPA 70-2023 [Definition: Fixed (as applied to equipment).]

Fixed (as applied to equipment).

Equipment that is fastened or otherwise secured at a specific location. (680) (CMP-17)

Statement of Problem and Substantiation for Public Input

Delete the reference to Article (680) from the definition. Code readers need a definition of the word "Fixed" that can be applied throughout the code rather than being limited to only Article 680 applications.

The term "Fixed" is used throughout the code, not just in Article 680 applications.

I am also submitting similar public inputs for the definitions of "Fastened-in-Place", "Stationary", and "Fixed-in-Place."

Related Public Inputs for This Document

<u>Related Input</u>	<u>Relationship</u>
Public Input No. 4228-NFPA 70-2023 [Definition: Stationary (as applied to equipment).]	
Public Input No. 4230-NFPA 70-2023 [Definition: Fastened-in-Place.]	
Public Input No. 4231-NFPA 70-2023 [Definition: Fixed-in-Place.]	
Public Input No. 4228-NFPA 70-2023 [Definition: Stationary (as applied to equipment).]	
Public Input No. 4230-NFPA 70-2023 [Definition: Fastened-in-Place.]	
Public Input No. 4231-NFPA 70-2023 [Definition: Fixed-in-Place.]	
Public Input No. 4233-NFPA 70-2023 [Definition: Appliance.]	

Submitter Information Verification

Submitter Full Name: Jeffrey Simpson
Organization: ElectricalLicenseRenewal.com
Street Address:
City:
State:
Zip:
Submittal Date: Thu Sep 07 01:39:52 EDT 2023
Committee: NEC-P17

Committee Statement

Resolution: [FR-9009-NFPA 70-2024](#)

Statement: The term "Fixed" is used in articles beyond Article 680, but still relates to CMP17 for many of its uses, therefore should remain under purview of CMP17, and not change to CMP 1.



Public Input No. 901-NFPA 70-2023 [Definition: Low-Voltage Contact Limit.]

Low-Voltage Contact Limit.

A voltage not exceeding the following values:

- (1) 15 volts (RMS) for sinusoidal ac
 - (2) 21.2 volts peak for nonsinusoidal ac
 - (3) 30 volts for continuous dc
 - (4) 12.4 volts peak for dc that is interrupted at a rate of 10 to 200 Hz
- (680)-(CMP-17)

Statement of Problem and Substantiation for Public Input

This term is used in more locations than just Article 680, such as 555.38.

Submitter Information Verification

Submitter Full Name: Ryan Jackson

Organization: Self-employed

Street Address:

City:

State:

Zip:

Submittal Date: Sat May 27 22:16:44 EDT 2023

Committee: NEC-P17

Committee Statement

Resolution: [FR-9010-NFPA 70-2024](#)

Statement: The term "Low-Voltage Contact Limit" is used in articles beyond Article 680 but still relates to CMP17 for many of its uses. The reference to Article 680 is being removed, and should remain under purview of CMP17.



Public Input No. 1678-NFPA 70-2023 [Definition: Pool, Permanently Installed Swimming, Wading, I...]

Pool, Permanently Installed Swimming, Wading, Immersion, and Therapeutic. (Permanently Installed Swimming, Wading, Immersion, and Therapeutic Pools)

Those that are constructed or installed in the ground or partially in the ground, and all pools installed on or inside of a building, whether or not served by electrical circuits of any nature. (680) (CMP-17)

Additional Proposed Changes

<u>File Name</u>	<u>Description</u>	<u>Approved</u>
rooftop_pool.jpg	rooftop pool	

Statement of Problem and Substantiation for Public Input

This PI proposes to clarify the definition of a permanently installed pool. The supporting picture shows a pool on the rooftop of a hotel. A literal reading of the current definition does not consider this a permanently installed pool as it is not installed "inside of a building". By adding "on" a building, there should be no question that this type of pool installation meets the definition.

Submitter Information Verification

Submitter Full Name: Vincent Della Croce

Organization:

Street Address:

City:

State:

Zip:

Submittal Date: Fri Jul 28 14:25:50 EDT 2023

Committee: NEC-P17

Committee Statement

Resolution: [FR-9012-NFPA 70-2024](#)

Statement: These changes include "above ground", and "pools on a building", and are intended to clarify the pool types intended to be covered by this definition.





Public Input No. 1712-NFPA 70-2023 [Definition: Pool, Permanently Installed Swimming, Wading, I...]

Pool, Permanently Installed Swimming, Wading, Immersion, and Therapeutic. (Permanently Installed Swimming, Wading, Immersion, and Therapeutic Pools)

Those that are permanently constructed or installed in the ground or partially in the ground, ~~and all pools installed on the ground, above the ground, or inside of a building, whether or not served by electrical circuits of any nature, with or without associated electrically powered equipment.~~ (680) (CMP-17)

Statement of Problem and Substantiation for Public Input

Input submitted to improve clarity and assumed intent. The objective of previous changes appeared to be an attempt to separate pools into two categories; permanent and storable; regardless of pool/water depth. Current definition uses a list included in a sentence to describe types of permanent pools and includes in ground, partially in ground, and pools inside buildings. That list does not include permanent pools installed on or above the ground. On ground and above ground pools are common.

Submitter Information Verification

Submitter Full Name: Donald Cook
Organization: Dewberry/Edmonds Engineering
Affiliation: self
Street Address:
City:
State:
Zip:
Submittal Date: Sat Jul 29 16:02:43 EDT 2023
Committee: NEC-P17

Committee Statement

Resolution: [FR-9012-NFPA 70-2024](#)

Statement: These changes include “above ground”, and “pools on a building”, and are intended to clarify the pool types intended to be covered by this definition.



Public Input No. 234-NFPA 70-2023 [Definition: Pool, Permanently Installed Swimming, Wading, I...]

Pool, Permanently Installed Swimming, Wading, Immersion, and Therapeutic. (Permanently Installed Swimming, Wading, Immersion, and Therapeutic Pools)

Those that are constructed or installed in the ground or partially in the ground, and all pools constructed or installed inside of a building, or on a building whether or not served by electrical circuits of any nature. (680) (CMP-17)

Additional Proposed Changes

<u>File Name</u>	<u>Description</u>	<u>Approved</u>
Permanantly_installed_pools.pdf	Rooftop pools ON buildings rather than INSIDE buildings	

Statement of Problem and Substantiation for Public Input

Pools can be either "installed" or "constructed" inside of buildings. But they can also be "installed" or "constructed" ON the outside of the building too! Rooftop pools come to mind. Is a rooftop pool considered INSIDE the building or ON the building? This could potentially cause different interpretations. A one-piece fiberglass pool that is set into the floor or roof by a lift or a crane would be considered "installed". But, a pool assembled of rebar, and sprayed or poured concrete would probably be better described as "constructed". These installations could happen INSIDE the building or ON the building. This definition needs to be revised to capture all of these various constructions and locations.

Submitter Information Verification

Submitter Full Name: Russ Leblanc
Organization: Leblanc Consulting Services
Street Address:
City:
State:
Zip:
Submittal Date: Sat Jan 28 10:12:50 EST 2023
Committee: NEC-P17

Committee Statement

Resolution: [FR-9012-NFPA 70-2024](#)

Statement: These changes include "above ground", and "pools on a building", and are intended to clarify the pool types intended to be covered by this definition.

This pool installed or constructed ON the rooftop does not meet the definition of “Pool, Permanently Installed Swimming, Wading, Immersion, and Therapeutic. (Permanently Installed Swimming, Wading, Immersion, and Therapeutic Pools)” since it is not “inside of a building”.



This pool installed or constructed ON the rooftop does not meet the definition of “Pool, Permanently Installed Swimming, Wading, Immersion, and Therapeutic. (Permanently Installed Swimming, Wading, Immersion, and Therapeutic Pools)” since it is not “inside of a building”.



This pool installed or constructed ON the rooftop does not meet the definition of “Pool, Permanently Installed Swimming, Wading, Immersion, and Therapeutic. (Permanently Installed Swimming, Wading, Immersion, and Therapeutic Pools)” since it is not “inside of a building”.



This pool installed or constructed ON the rooftop does not meet the definition of “Pool, Permanently Installed Swimming, Wading, Immersion, and Therapeutic. (Permanently Installed Swimming, Wading, Immersion, and Therapeutic Pools)” since it is not “inside of a building”.



This pool installed or constructed ON the rooftop does not meet the definition of “Pool, Permanently Installed Swimming, Wading, Immersion, and Therapeutic. (Permanently Installed Swimming, Wading, Immersion, and Therapeutic Pools)” since it is not “inside of a building”.



This pool installed or constructed ON the rooftop does not meet the definition of “Pool, Permanently Installed Swimming, Wading, Immersion, and Therapeutic. (Permanently Installed Swimming, Wading, Immersion, and Therapeutic Pools)” since it is not “inside of a building”.



This pool installed or constructed ON the rooftop does not meet the definition of “Pool, Permanently Installed Swimming, Wading, Immersion, and Therapeutic. (Permanently Installed Swimming, Wading, Immersion, and Therapeutic Pools)” since it is not “inside of a building”.





Public Input No. 2510-NFPA 70-2023 [Definition: Pool, Permanently Installed Swimming, Wading, I...]

Pool, Permanently Installed Swimming, Wading, Immersion, and Therapeutic. (Permanently Installed Swimming, Wading, Immersion, and Therapeutic Pools)

Those that are constructed or installed in the ground or partially in the ground, ~~and~~ all pools installed inside of a building, and all pool not defied as storable, whether or not served by electrical circuits of any nature. (680) (CMP-17)

Statement of Problem and Substantiation for Public Input

Revisions made for the 2023 edition inadvertently removed pools such as rooftop pools and aboveground pools from the definition. Obviously it was not intended, but it needs to be fixed.

Submitter Information Verification

Submitter Full Name: Ryan Jackson
Organization: Self-employed
Street Address:
City:
State:
Zip:
Submittal Date: Fri Aug 18 13:45:33 EDT 2023
Committee: NEC-P17

Committee Statement

Resolution: [FR-9012-NFPA 70-2024](#)

Statement: These changes include “above ground”, and “pools on a building”, and are intended to clarify the pool types intended to be covered by this definition.



Public Input No. 3695-NFPA 70-2023 [Definition: Pool, Permanently Installed Swimming, Wading, I...]

Pool, Permanently Installed Swimming, Wading, Immersion, and Therapeutic. (Permanently Installed Swimming, Wading, Immersion, and Therapeutic Pools)

Those that are constructed or installed in the ground

or

partially in the ground, or completely above the ground, and all pools installed inside of a building, whether or not served by electrical circuits of any nature. (680)(CMP-17).

Statement of Problem and Substantiation for Public Input

There are some permanent pools that are constructed completely above ground and should be included.

Related Public Inputs for This Document

<u>Related Input</u>	<u>Relationship</u>
<u>Public Input No. 3681-NFPA 70-2023 [New Definition after Definition: Pool, Permanently Installe...]</u>	revision of definition
<u>Public Input No. 3700-NFPA 70-2023 [Definition: Pool, Storable; used for Swimming, Wading, or I...]</u>	
<u>Public Input No. 3710-NFPA 70-2023 [Part II.]</u>	
<u>Public Input No. 3719-NFPA 70-2023 [Section No. 680.20]</u>	

Submitter Information Verification

Submitter Full Name: Ronald Dalrymple
Organization: City of Schertz Texas
Street Address:
City:
State:
Zip:
Submittal Date: Tue Sep 05 14:16:22 EDT 2023
Committee: NEC-P17

Committee Statement

Resolution: FR-9012-NFPA 70-2024

Statement: These changes include “above ground”, and “pools on a building”, and are intended to clarify the pool types intended to be covered by this definition.



Public Input No. 2205-NFPA 70-2023 [Definition: Pool, Storable; used for Swimming, Wading, or I...]

Pool, Storable; used for Swimming, Wading, or Immersion (Storable Immersion Pool). (Storable Pool)

Pools of any water depth installed entirely on or above the ground that are intended to be stored when not in use and are designed for ease of relocation, ~~regardless of water depth~~. (680) (CMP-17)

Statement of Problem and Substantiation for Public Input

This PI makes no technical changes. It only proposes to relocate the water depth language to the beginning of the definition for clarity and usability.

Submitter Information Verification

Submitter Full Name: Vincent Della Croce

Organization:

Street Address:

City:

State:

Zip:

Submittal Date: Mon Aug 14 15:08:16 EDT 2023

Committee: NEC-P17

Committee Statement

Resolution: [FR-9014-NFPA 70-2024](#)

Statement: The definition is being revised to add clarity, without changing the meaning. New informational note was added to indicate that a pool with permanent deck is to be treated as a permanently installed pool.



Public Input No. 3700-NFPA 70-2023 [Definition: Pool, Storable; used for Swimming, Wading, or I...]

Pool, Storable; used for Swimming, Wading, or Immersion (Storable Immersion Pool). (Storable Pool)

Pools installed entirely on or above the ground that are intended to be stored when not in use and are designed for ease of relocation, and do not require modifications to the pool site regardless of water depth, or wiring system, pool does not have a pump, or pump has a longer built in power cord over 3ft in length to allow for use of existing premises receptacles (680) (CMP-17)

Statement of Problem and Substantiation for Public Input

This definition revision is to help clarify that not all above ground pools are meant to be storable. This goes with a new definition of semi-permanent pools to ensure they are bonded per section 680.26

Related Public Inputs for This Document

<u>Related Input</u>	<u>Relationship</u>
Public Input No. 3681-NFPA 70-2023 [New Definition after Definition: Pool, Permanently Installe...]	new definition
Public Input No. 3695-NFPA 70-2023 [Definition: Pool, Permanently Installed Swimming, Wading, I...]	revised definition
Public Input No. 3710-NFPA 70-2023 [Part II.]	
Public Input No. 3719-NFPA 70-2023 [Section No. 680.20]	

Submitter Information Verification

Submitter Full Name: Ronald Dalrymple
Organization: City of Schertz Texas
Street Address:
City:
State:
Zip:
Submittal Date: Tue Sep 05 14:22:43 EDT 2023
Committee: NEC-P17

Committee Statement

Resolution: The proposed revisions do not add clarity to what is considered a "Storable Pool" vs "Permanently Installed Pool" and may be considered requirements rather than terms. NEC Style Manual 2.2.1.5 requires that definitions not contain requirements or recommendations.



Public Input No. 211-NFPA 70-2023 [Definition: Pool.]

Pool.

Manufactured or field-constructed equipment designed to contain water on a permanent or semipermanent basis and used by persons for swimming, wading, immersion, or therapeutic purposes, but not including bodies of water incorporated as part of an industrial process or lakes, lagoons, surf parks, or other natural and man-made bodies of water that may incorporate swimming and swimming areas .(680) (CMP-17)

Informational Note: Natural and man-made bodies of water, which includes lakes, lagoons, surf parks, or other similar bodies of water, are addressed in Article 682.

Statement of Problem and Substantiation for Public Input

This change in definition of "Pool" was approved by the Task Group addressing TIA 1867 for the 2023 Edition, and is submitted for consideration by CMP-17 as a companion to the Task Group recommendations for changes to NEC 680.26(A) and NEC 680.26(B)(2), in the event the TIA is not adopted.

The Task Group's substantiation for the change herein is as follows (including the introductory material) and is submitted as substantiation for this change (copied from the TIA submission):

"This Tentative Interim Amendment (TIA) is proposed by a Task Group appointed by NFPA staff pursuant to the decision of the Standards Council D#22-3 on Agenda item SC#22-8-5-w-1 as voted 12 August 2022. This decision denied the underlying appeal, but found that issues raised at the hearing relative to current research and loss experience required "timely analysis." Given the "highly technical nature" of the subject matter, the Council directed that this Task Group be one that was "balanced" and that possessed the technical expertise to evaluate the relevant research. As there is considerable controversy over this issue, the focus was reaching common ground which would result in a practical compromise acceptable to the participants.

"The Task Group focused its attention on 680.26(B)(2) which covers the bonding of the surfaces that make up the perimeter of a swimming pool. After extensive discussion, the Task Group is proposing a complete rewrite of this material, as well as related material within the scope of CMP 17. The detailed substantiation follows:

[Regarding this change in definition of "Pool"] "The Task Group considered action by inspectors in some jurisdictions that consider large bodies of water with limited beaches, many acres in size, as pools because they are used for swimming. In such instances, the perimeter bonding requirements have resulted in requirements to bury bare solid 8 AWG around the entire perimeter of such bodies of water. These applications are clearly covered in Article 682, and the revised text makes that clear."

Related Public Inputs for This Document

<u>Related Input</u>	<u>Relationship</u>
<u>Public Input No. 212-NFPA 70-2023 [Section No. 680.26(A)]</u>	Companion submittal originally incorporated as part of TIA.
<u>Public Input No. 213-NFPA 70-2023 [Section No. 680.26(B)(2)]</u>	Companion submittal originally incorporated as part of TIA.
<u>Public Input No. 212-NFPA 70-2023 [Section No. 680.26(A)]</u>	
<u>Public Input No. 213-NFPA 70-2023 [Section No. 680.26(B)(2)]</u>	

Submitter Information Verification

Submitter Full Name: E. P. Hamilton
Organization: E. P. Hamilton & Associates, Inc.
Street Address:
City:
State:
Zip:
Submittal Date: Sat Jan 21 17:52:22 EST 2023
Committee: NEC-P17

Committee Statement

Resolution: [FR-9017-NFPA 70-2024](#)

Statement: To aid the user and provide further clarification, additional specific installation types are referenced in the definition, and excluded from the definition, as well as an Informational Note, regarding what is considered a Pool and what is not considered a Pool.

“Permanent” and “Semi-Permanent” are removed from the definition as how long the pool is intended to remain is not relevant to the term Pool.

Additionally, “man-made bodies of water” is revised to “artificially-made bodies of water” since this is a defined term.



Public Input No. 2862-NFPA 70-2023 [Definition: Pool.]

Pool.

Manufactured or field-constructed equipment designed to contain water on a permanent or semipermanent basis and used by persons for swimming, wading, immersion, or therapeutic purposes, but not including bodies of water incorporated as part of an industrial process ~~or lakes or lagoons~~, ~~lagoons~~, surf parks, or other natural ~~and man-made bodies~~ or artificially made bodies of water that may incorporate swimming and swimming areas. (680) (CMP-17)

Informational Note: Natural and ~~man-made~~ artificially made bodies of water, which includes lakes, lagoons, surf parks, or other similar bodies of water, are addressed in Article 682.

Statement of Problem and Substantiation for Public Input

This PI proposed to correlate the definition of a pool. The word "lake" is deleted as it is already included in the definition of "natural bodies of water". "Man-made bodies of water" is deleted as it is not a defined term, and replaced with the defined term "artificially mad bodies of water".

Submitter Information Verification

Submitter Full Name: Vincent Della Croce

Organization:

Street Address:

City:

State:

Zip:

Submission Date: Fri Aug 25 16:53:17 EDT 2023

Committee: NEC-P17

Committee Statement

Resolution: [FR-9017-NFPA 70-2024](#)

Statement: To aid the user and provide further clarification, additional specific installation types are referenced in the definition, and excluded from the definition, as well as an Informational Note, regarding what is considered a Pool and what is not considered a Pool.

“Permanent” and “Semi-Permanent” are removed from the definition as how long the pool is intended to remain is not relevant to the term Pool.

Additionally, “man-made bodies of water” is revised to “artificially-made bodies of water” since this is a defined term.



Public Input No. 295-NFPA 70-2023 [Definition: Pool.]

Pool.

Manufactured or field-constructed equipment designed to contain water on a permanent, seasonal, or ~~semipermanent~~ temporary basis and used for swimming, wading, immersion, or therapeutic purposes, but excluding splash pads; and natural and artificially-made bodies of water that incorporate swimming, wading or immersion areas. (680) (CMP-17)

Informational Note: Natural and artificially-made bodies of water such as lakes, lagoons, surf parks, rivers, streams, aeration ponds, fish farm ponds, storm retention basins, treatment ponds, irrigation channels, or other similar bodies of water are not considered to be pools.

Statement of Problem and Substantiation for Public Input

- Use standardized terminology like "seasonal" and "temporary".
- Are not some storable pools of Article 680 Part III for very temporary immersion, wading and swimming usage? "Permanent" and "semipermanent" are not necessarily applicable to storable pools?
- "Semipermanent"? What's next? Article 595 for "Semipermanent Installations"? Pangea was semipermanent as a continent! Given the hydrological cycle, all water is permanent, short of the fusion of two hydrogen atoms with one oxygen atom.
- "Splash pad" is defined separately in Article 100 and is included in the requirements of Article 680 Part V, distinct from Parts II and Part III for pools.

Submitter Information Verification

Submitter Full Name: Brian Rock
Organization: Hubbell Incorporated
Street Address:
City:
State:
Zip:
Submittal Date: Tue Feb 07 18:33:08 EST 2023
Committee: NEC-P17

Committee Statement

Resolution: [FR-9017-NFPA 70-2024](#)

Statement: To aid the user and provide further clarification, additional specific installation types are referenced in the definition, and excluded from the definition, as well as an Informational Note, regarding what is considered a Pool and what is not considered a Pool.

"Permanent" and "Semi-Permanent" are removed from the definition as how long the pool is intended to remain is not relevant to the term Pool.

Additionally, "man-made bodies of water" is revised to "artificially-made bodies of water" since this is a defined term.



Public Input No. 3994-NFPA 70-2023 [Definition: Portable (as applied to equipment).]

Portable (as applied to equipment):

Equipment that is actually moved or can easily be moved from one place to another in normal use. (680) (CMP-17)

Statement of Problem and Substantiation for Public Input

Both "portable" and "equipment" are already defined terms. Combining two broad definitions to create a third broad definition only complicates the code. The two previously mentioned definitions should be sufficient to provide understanding of what portable equipment is.

Related Public Inputs for This Document

<u>Related Input</u>	<u>Relationship</u>
Public Input No. 3992-NFPA 70-2023 [Definition: Portable.]	
Public Input No. 3992-NFPA 70-2023 [Definition: Portable.]	

Submitter Information Verification

Submitter Full Name: Matthew Grover
Organization: Kings Electric Services
Street Address:
City:
State:
Zip:
Submittal Date: Wed Sep 06 12:55:18 EDT 2023
Committee: NEC-P17

Committee Statement

Resolution: The terms "Portable" and "Portable Equipment" are used in many locations throughout the code. This instance as applied only to Article 680 serves the needs for Pool and Spa applications. CMP17 does not see a benefit in removing this Definition.



Public Input No. 2351-NFPA 70-2023 [Definition: Stationary (as applied to equipment).]

Stationary (as applied to equipment).

Equipment that is not moved from one place to another in normal use. (680)-(CMP-47 1)

Statement of Problem and Substantiation for Public Input

The term 'stationary' is used 62 times in the Code. This definition is a very common word that should apply in general and not just to Article 680 requirements. This definition should also fall under the purview of CMP-1. The proposed revisions will enhance usability throughout the NEC.

Submitter Information Verification

Submitter Full Name: Mike Holt
Organization: Mike Holt Enterprises Inc
Street Address:
City:
State:
Zip:
Submittal Date: Wed Aug 16 14:10:07 EDT 2023
Committee: NEC-P17

Committee Statement

Resolution: [FR-9019-NFPA 70-2024](#)

Statement: The term "Stationary (as applied to equipment)" is used in Article 680 and is also used in other articles. To make it applicable in a larger scope, the reference only to Article 680 is being removed. Since it is used extensively in Article 680, CMP17 reference is being retained.



Public Input No. 4228-NFPA 70-2023 [Definition: Stationary (as applied to equipment).]

Stationary (as applied to equipment).

Equipment that is not moved from one place to another in normal use. ~~(680)~~ (CMP-17)

Statement of Problem and Substantiation for Public Input

Delete the reference to Article (680) from the definition. Code readers need a definition of the word "Stationary" that can be applied throughout the code rather than being limited to only Article 680 applications.

The term "Stationary" (as applied to equipment) is used throughout the code, not just in Article 680 applications.

I am also submitting similar public inputs for the definitions of "Fastened-in-Place", "Fixed", and "Fixed-in-Place".

Related Public Inputs for This Document

<u>Related Input</u>	<u>Relationship</u>
Public Input No. 4229-NFPA 70-2023 [Definition: Fixed (as applied to equipment).]	
Public Input No. 4230-NFPA 70-2023 [Definition: Fastened-in-Place.]	
Public Input No. 4231-NFPA 70-2023 [Definition: Fixed-in-Place.]	
Public Input No. 4229-NFPA 70-2023 [Definition: Fixed (as applied to equipment).]	
Public Input No. 4230-NFPA 70-2023 [Definition: Fastened-in-Place.]	
Public Input No. 4231-NFPA 70-2023 [Definition: Fixed-in-Place.]	

Submitter Information Verification

Submitter Full Name: Jeffrey Simpson
Organization: ElectricalLicenseRenewal.com
Street Address:
City:
State:
Zip:
Submittal Date: Thu Sep 07 01:13:17 EDT 2023
Committee: NEC-P17

Committee Statement

Resolution: [FR-9019-NFPA 70-2024](#)

Statement: The term "Stationary (as applied to equipment)" is used in Article 680 and is also used in other articles. To make it applicable in a larger scope, the reference only to Article 680 is being removed. Since it is used extensively in Article 680, CMP17 reference is being retained.



Public Input No. 3479-NFPA 70-2023 [New Definition after Definition:

Concealed Knob-and-Tube Wi...]

TITLE OF NEW CONTENT

Add the following new definition to Article 100

Conductive Pavement Heating System . A system in which heat is generated by passing current between electrodes embedded within the pavement material and through the pavement material. The pavement material may be primarily of concrete, or asphalt, or the like, and is typically constructed as bridge structures, walks, steps, roads or parking areas. (426) (CMP-17)

Statement of Problem and Substantiation for Public Input

This is a new definition to be added as part of a new Part VI in Article 426 for electrically conductive pavement heating systems where the pavement is part of the heating circuit. This new part in Article 426 is to provide requirements for the safe installation of such systems that have been under development for several years with a number of installations completed for research purposes. The definition is needed to establish the new term for understanding how the requirements are to be applied to these new innovative snow melting and deicing systems.

Related Public Inputs for This Document

<u>Related Input</u>	<u>Relationship</u>
Public Input No. 4168-NFPA 70-2023 [Article 426]	New part using defined term.
Public Input No. 4168-NFPA 70-2023 [Article 426]	

Submitter Information Verification

Submitter Full Name: Charles Mello
Organization: cdc_mello Consulting LLC
Affiliation: Iowa Department of Transportation
Street Address:
City:
State:
Zip:
Submittal Date: Sun Sep 03 18:51:48 EDT 2023
Committee: NEC-P17

Committee Statement

Resolution: [CI-8998-NFPA 70-2024](#)

Statement: CMP17 has reviewed public inputs 3479 and 4168 regarding conductive heated pavement systems and has decided to provide this committee input in order to solicit public review and comments.

CMP17 solicits comments regarding if pavement heating systems warrant specific requirements and/or separate a Part in Art 426, and do the specific requirements originally proposed in public inputs 3479 and 4168 sufficiently address the safety

concerns. Currently, CMP 17 has initial concerns such as, but not necessarily limited to:

- 1) The lack of a product listing standard or outline of investigation clarifying appropriate product performance and safety requirements.
- 2) GFCI and/or GFPE protection or other shock protection measures
- 3) Grounding & bonding
- 4) Capacitive coupling
- 5) Scope of use
- 6) Accessible and acceptable contact voltages on or near the surface of the heated pavement, after damage or possible deterioration of the heated pavement such as wear, cracks, potholes, or penetrations into the heated pavement surface, such as signage, guard rails, benches, etc.
- 7) The use of a grounded or an ungrounded system
- 8) Limits on applied system voltage.
- 9) Concerns with lightning strikes.
- 10) Impact on local utilities.

After public comments are received, as well as progress of development of product safety standards, additional concerns may be presented for consideration.



Public Input No. 3681-NFPA 70-2023 [New Definition after Definition: Pool, Permanently Installe...]

Pool, Semi-Permanent; used for Swimming, Wading, or Immersion.

Pools installed on or above the ground that are not designed for ease of relocation, regardless of being able to be disassembled by hand or with hand tools, and typically require site preparation, or modifications of the electrical system. (680)(CMP-17) ...

Statement of Problem and Substantiation for Public Input

Using the two definitions for Permanent pools and Storable pools leaves a type of above ground pool in limbo of what is required for electrical safety. This type of pool is not meant to be stored when not in use as can be seen in most installation instructions on "how to winterize your pool" which leaves it outside and not stored. My particular concern is the equipotential bonding that's required in section 680.26 . This will require clarification of the definitions for permanently and storable pools. It will also require adding Semi-permanent pools to the title of part II. "Permanently installed pools, and semi-permanently installed pools". I am also sending in input for definition revisions for those 2 definitions. also a change to 680.20 should read as follows "Electrical installations at permanently and semi-permanently installed pools shall comply with the provisions of Part I and Part II of this article."

Related Public Inputs for This Document

<u>Related Input</u>	<u>Relationship</u>
Public Input No. 3695-NFPA 70-2023 [Definition: Pool, Permanently Installed Swimming, Wading, I...]	
Public Input No. 3700-NFPA 70-2023 [Definition: Pool, Storable; used for Swimming, Wading, or I...]	
Public Input No. 3710-NFPA 70-2023 [Part II.]	
Public Input No. 3719-NFPA 70-2023 [Section No. 680.20]	

Submitter Information Verification

Submitter Full Name: Ronald Dalrymple
Organization: City of Schertz Texas
Street Address:
City:
State:
Zip:
Submittal Date: Tue Sep 05 13:46:38 EDT 2023
Committee: NEC-P17

Committee Statement

Resolution: The submitter's objectives are addressed by the revisions of the definitions of "permanently installed pools" and "storable pools." The type of pool suggested in the public input is now considered to be a storable pool unless a permanent deck is installed around all or part of the pool. Therefore, the term "semi-permanently installed pools" is not being added to the title of Part II.



Public Input No. 3462-NFPA 70-2023 [New Section after 422.5]

422.6 Safety Interlock Outlet Protection

All 125-volt 15 ampere receptacle outlets for cord-and-plug-connected refrigerators, freezers, dishwashers, microwave ovens, clothes washers, air conditioning units, and other appliances within enclosed spaces such as closets, cabinets, and pantries shall be protected by a listed safety interlock outlet that includes smoke and heat sensors to deenergize the outlet that supplies the protected appliances.

Statement of Problem and Substantiation for Public Input

The intent of this public input is to create a new 422.6 for Safety Interlock Outlet Protection, and re-number existing 422.6 as 422.7.

Major appliance fires are commonplace and have caused a significant amount of property damage, injuries and deaths. From 2010 to 2014, U.S. municipal fire departments responded to an estimated 15,970 home fires involving clothes dryers or washing machines each year. These fires resulted in annual losses estimated at 13 civilian deaths, 440 civilian injuries, and \$238 million in direct property damage.

From 2018 to 2020, the U.S. Consumer Product Safety Commission estimates there were approximately 360,800 residential fires annually. Of these, the CPSC estimates there were 1,400 air conditioning unit fires annually, 800 microwave fires annually, 800 refrigerator and freezer fires annually, 500 dishwasher fires annually, and 400 washing machine fires annually.

Please see this data at https://www.cpsc.gov/s3fs-public/2018-to-2020-Residential-Fire-Loss-Estimates-Annual-Fire-Loss-Report-Final.pdf?VersionId=si8dwpdtl36yYn_Piq3TQ0HDBz8rZLGb

A significant number of product recalls have taken place in recent years.

In October 2017, the CPSC recalled 408,000 defective dishwashers due to a problem with overheating.

On June 16, 2021, about 42,000 dishwashers were recalled due to a problem with overheating caused by defective cords.

On September 26, 2019, about 26,600 dishwashers were recalled due to a problem with overheating caused by defective cords.

From 2002 to 2009, nearly 15 million appliances were recalled for defects that could cause a fire, according to CPSC records, with 1,942 incidents reported. Almost half of the recalled units were dishwashers.

One of the largest recalls involved 1.6 million Maytag refrigerators that were recalled in March 2009 because of an electrical failure in the relay that turns on the compressor.

Despite these recalls, CPSC data indicates there are still a significant number of major appliance fires. As can be seen from the CPSC data, there remains an electrical safety hazard caused by defective major appliances. Having a means to de-energize electrical power to the appliance upon detection of smoke or heat could significantly reduce this hazard.

Many electrical fires will produce measurable quantities of smoke before flaming exists. This is particularly true of overheated electrical insulation. Smoke detection has resulted in saving countless lives since it was introduced in the 1970s. However, smoke from an overheating appliance inside a cabinet or enclosure will not immediately be detected by a ceiling mounted smoke alarm or detector in

the area.

NFPA 72, National Fire Alarm and Signaling Code only requires smoke detection in sleeping rooms, outside separate sleeping areas, and on each level of the home (usually near stairs). Smoke detection is not required in laundry areas, mud rooms, closets, or other areas where major appliances are installed.

A safety interlock outlet with a smoke and heat sensor is designed to detect smoke and heat from an appliance fire in an enclosed space, such as under a base cabinet, laundry closet, or in a small, enclosed area. The smoke and heat detector are powered by the outlet and are placed in the cabinet or enclosure with the appliance. Many electrical fires will produce measurable quantities of smoke before flaming exists. This is particularly true of overheated electrical insulation. When heat or smoke is detected, the safety interlock is activated, and power is immediately deenergized. Additionally, a sounder will provide indication of the presence of smoke or heat. For an example of this protection method, see this link: <https://dockingdrawer.com/collections/fire-guard-outlet>

Having a smoke and heat detector with a safety interlock outlet in the enclosure with the protected appliance (inside the enclosure or cabinet) will detect the fire much sooner than a ceiling mounted smoke alarm or detector. A safety interlock outlet with a smoke and heat detector will also actively take steps to de-energize the circuit and mitigate electrical hazards.

Submitter Information Verification

Submitter Full Name: Merton Bunker
Organization: Merton Bunker & Associates, LLC
Affiliation: Docking Drawer a division of JTech Solutions Inc.
Street Address:
City:
State:
Zip:
Submittal Date: Sun Sep 03 11:15:49 EDT 2023
Committee: NEC-P17

Committee Statement

Resolution: If this type of protection is needed the requirements would need to be coordinated with the applicable product safety standards for the appliance it is used with. The public input seeks to require a "listed safety interlock outlet," but the CMP is not aware of specific product safety standards that exist for such an outlet. The device shown in the substantiation is listed to UL 498 and UL 60730-2-9, neither of which address "safety interlock outlet" or smoke detection capabilities. Smoke detection in localized areas may be better addressed in NFPA 72 or the applicable building code.



Public Input No. 1548-NFPA 70-2023 [Section No. 422.5(A)]

(A) General.

Appliances identified in 422.5(A)(1) through (A)(7) 150 volts or less to ground and 60 amperes or less, single- or 3-phase, shall be provided with Class A protection for personnel. Multiple Class A protective devices shall be permitted but shall not be required.

- (1) Automotive vacuum machines
- (2) Drinking water coolers and bottle fill stations
- (3) Cord-and-plug-connected high-pressure spray washing machines
- (4) Tire inflation machines
- (5) Vending machines
- (6) Sump pumps
- (7) Dishwashers

Informational Note: Section 210.8 specifies requirements for GFCI protection for the branch-circuit outlet where the covered location warrants such protection.

Statement of Problem and Substantiation for Public Input

Clarification.

Include in 422.5(A) all appliances added to 210.8(D), including electric ranges, wall-mounted ovens, counter-mounted cooking units, clothes dryers, and microwave ovens.

Submitter Information Verification

Submitter Full Name: Dallas Barrow

Organization: [Not Specified]

Street Address:

City:

State:

Zip:

Submittal Date: Tue Jul 25 09:40:49 EDT 2023

Committee: NEC-P17

Committee Statement

Resolution: Insufficient technical substantiation has been submitted to expand the list. Additionally, representatives for both UL 101 Leakage Current for Utilization Equipment and UL 943 GFCIs, as well as other industry stakeholders, are engaged in ongoing discussions concerning GFCI protection and appliance compatibility. This includes possible development of a Class A-HF GFCI to address compatibility concerns with appliances generating frequencies greater than 60 Hz. A timeframe for compatibility within these product standards has not been established. CMP 2 has purview of the branch circuit requirements in 210.8(D) and CMP 17 has purview over the requirements in 422.5(A).



Public Input No. 1677-NFPA 70-2023 [Section No. 422.5(A)]

(A) General.

Appliances identified in 422.5(A)(1) through (A)(7) 150 volts or less to ground and 60 amperes or less, single- or 3-phase, shall be provided with Class A protection for personnel. Multiple Class A protective devices shall be permitted but shall not be required.

- (1) Automotive vacuum machines
- (2) Drinking water coolers and bottle fill stations
- (3) Cord-and-plug-connected high-pressure spray washing machines
- (4) Tire inflation machines
- (5) Vending machines
- (6) Sump pumps
- (7) Dishwashers

Informational Note: Section 210.8 specifies requirements for GFCI protection for the branch-circuit outlet where the covered location warrants such protection.

Statement of Problem and Substantiation for Public Input

Section 422.5 (A) (2) of NEC 2023 presently requires gfi protection for 'Drinking water coolers and bottle fill stations.' Proposed change is to add the 'drinking water fountains' also as many times architects and plumbing engineers indicate 'Drinking water fountains' on the plans. This will avoid any arguments at the time of plan review and inspection time.

Submitter Information Verification

Submitter Full Name: Mohinder Sood
Organization: Core Engineers
Street Address:
City:
State:
Zip:
Submittal Date: Fri Jul 28 14:17:32 EDT 2023
Committee: NEC-P17

Committee Statement

Resolution: [FR-8871-NFPA 70-2024](#)

Statement: This section is editorially revised by creating sub-divisions (A), (B) and (C), including a charging statement. The permission for multiple GFCI devices is now in the charging statement and Class A is revised to the defined term acronym GFCI.

First level sub-division (A) is retitled to "circuit rating" to more accurately describe the requirements that follow. This sub-division is also revised to base the appliance GFCI protection on the branch circuit rating and not the rating of the appliance. The voltage and rating thresholds are put into list item form for clarity. A reference to the low voltage

contact limit, a defined term in Article 100, is added to clarify that GFCI protection is not required when the branch circuit voltage is below the defined thresholds.

First level sub-division (B) is created for clarity and includes the appliances that require GFCI protection. List item (1) is revised to “branch-circuit overcurrent protective device” to correlate with the defined term in Article 100. An informational note is added to provide guidance to industry that an electrically cooled drinking water fountain is a type of water cooler. The existing informational note is revised to comply with the NEC Style Manual, Section 2.1.10.

Insufficient technical substantiation has been submitted to expand the list. Additionally, representatives for both UL 101 Leakage Current for Utilization Equipment and UL 943 GFCIs, as well as other industry stakeholders, are engaged in ongoing discussions concerning GFCI protection and appliance compatibility.

A time frame for compatibility within these product standards has not been established.

CMP 2 has purview of the branch circuit requirements in 210.8(D) and CMP 17 has purview over the requirements in 422.5.

Existing sub-division (B) is changed to (C) for editorial purposes.



Public Input No. 1770-NFPA 70-2023 [Section No. 422.5(A)]

(A) General.

Appliances identified in 422.5(A)(1) through (A)(7 12) 150 volts or less to ground and 60 amperes or less, single- or 3-phase, shall be provided with Class A protection for personnel. Multiple Class A protective devices shall be permitted but shall not be required.

- (1) Automotive vacuum machines
- (2) Drinking water coolers and bottle fill stations
- (3) Cord-and-plug-connected high-pressure spray washing machines
- (4) Tire inflation machines
- (5) Vending machines
- (6) Sump pumps
- (7) Dishwashers
- (8) Electric ranges
- (9) Wall-mounted ovens
- (10) Counter-Mounted cooking units
- (11) Clothes dryers
- (12) Microwave ovens

Informational Note: Section 210.8 specifies requirements for GFCI protection for the branch-circuit outlet where the covered location warrants such protection.

Statement of Problem and Substantiation for Public Input

The two sections of 210.8 (D) and 422.5 (A) both list appliances that need GFCI protection. The two list do not match. Both list appliances, so the list should be the same in both places. The way it is now, causes confusion with the installers.

Submitter Information Verification

Submitter Full Name: IEC National
Organization: IEC
Affiliation: Lowell Reith IEC
Street Address:
City:
State:
Zip:
Submittal Date: Tue Aug 01 14:47:07 EDT 2023
Committee: NEC-P17

Committee Statement

Resolution: Insufficient technical substantiation has been submitted to expand the list. Additionally, representatives for both UL 101 Leakage Current for Utilization Equipment and UL 943 GFCIs, as well as other industry stakeholders, are engaged in ongoing discussions concerning GFCI protection and appliance compatibility. This includes possible development of a Class A-HF GFCI to address compatibility concerns with appliances generating frequencies greater than 60 Hz. A timeframe for compatibility within these product standards has not been established. CMP 2 has purview of the branch circuit requirements in 210.8(D) and CMP 17 has purview over the requirements in 422.5(A).



Public Input No. 3205-NFPA 70-2023 [Section No. 422.5(A)]

(A) General.

Appliances identified in 422.5(A)(1) through (A)(7) 150 volts or less to ground and 60 amperes or less, single- or 3-phase, shall be provided with ~~Class A~~ GFCI protection for personnel. Multiple ~~Class A~~ GFCI protective devices shall be permitted but shall not be required.

- (1) Automotive vacuum machines
- (2) Drinking water coolers and bottle fill stations
- (3) Cord-and-plug-connected high-pressure spray washing machines
- (4) Tire inflation machines
- (5) Vending machines
- (6) Sump pumps
- (7) Dishwashers
- (8) Electric ranges
- (9) Wall-mounted ovens
- (10) Counter-mounted cooking units
- (11) Clothes dryers
- (12) Microwave ovens

Informational Note: Section 210.8 specifies requirements for GFCI protection for the branch-circuit outlet where the covered location warrants such protection.

Statement of Problem and Substantiation for Public Input

Revised text from 'Class A device' to 'GFCI device' because the Article 100 definition for GFCI already states it must be a Class A device. Additionally, added text for 210.8(D)(8) through (12) for consistency of both these requirements. These proposed revisions will improve usability and add clarity for Code users.

Submitter Information Verification

Submitter Full Name: Mike Holt
Organization: Mike Holt Enterprises Inc
Street Address:
City:
State:
Zip:
Submission Date: Wed Aug 30 11:12:03 EDT 2023
Committee: NEC-P17

Committee Statement

Resolution: FR-8871-NFPA 70-2024

Statement: This section is editorially revised by creating sub-divisions (A), (B) and (C), including a charging statement. The permission for multiple GFCI devices is now in the charging statement and Class A is revised to the defined term acronym GFCI.

First level sub-division (A) is retitled to “circuit rating” to more accurately describe the requirements that follow. This sub-division is also revised to base the appliance GFCI protection on the branch circuit rating and not the rating of the appliance. The voltage and rating thresholds are put into list item form for clarity. A reference to the low voltage contact limit, a defined term in Article 100, is added to clarify that GFCI protection is not required when the branch circuit voltage is below the defined thresholds.

First level sub-division (B) is created for clarity and includes the appliances that require GFCI protection. List item (1) is revised to “branch-circuit overcurrent protective device” to correlate with the defined term in Article 100. An informational note is added to provide guidance to industry that an electrically cooled drinking water fountain is a type of water cooler. The existing informational note is revised to comply with the NEC Style Manual, Section 2.1.10.

Insufficient technical substantiation has been submitted to expand the list. Additionally, representatives for both UL 101 Leakage Current for Utilization Equipment and UL 943 GFCIs, as well as other industry stakeholders, are engaged in ongoing discussions concerning GFCI protection and appliance compatibility.

A time frame for compatibility within these product standards has not been established.

CMP 2 has purview of the branch circuit requirements in 210.8(D) and CMP 17 has purview over the requirements in 422.5.

Existing sub-division (B) is changed to (C) for editorial purposes.



Public Input No. 4486-NFPA 70-2023 [Section No. 422.5(A)]

(A) General.

Appliances identified in 422.5(A)(1) through (A)(7) 150 volts or less to ground ~~and~~ 60 amperes or less ~~single-phase,~~ or 100 amperes or less 3-phase, shall be provided with Class A protection for personnel. Multiple Class A protective devices shall be permitted but shall not be required.

- (1) Automotive vacuum machines
- (2) Drinking water coolers and bottle fill stations
- (3) Cord-and-plug-connected high-pressure spray washing machines
- (4) Tire inflation machines
- (5) Vending machines
- (6) Sump pumps
- (7) Dishwashers

Informational Note: Section 210.8 specifies requirements for GFCI protection for the branch-circuit outlet where the covered location warrants such protection.

Statement of Problem and Substantiation for Public Input

Appliances are now in use that are beyond the 60 A value currently stated in the code. GFCI devices are commercially available at this amperage rating, and moving the three-phase limit to 100 A correlates to the existing 210.8(B) requirement.

Related Public Inputs for This Document

<u>Related Input</u>	<u>Relationship</u>
Public Input No. 4477-NFPA 70-2023 [Section No. 210.8(D)]	
Public Input No. 4477-NFPA 70-2023 [Section No. 210.8(D)]	

Submitter Information Verification

Submitter Full Name: Mark Pollock
Organization: Littelfuse
Street Address:
City:
State:
Zip:
Submittal Date: Thu Sep 07 16:22:07 EDT 2023
Committee: NEC-P17

Committee Statement

Resolution: Insufficient technical substantiation has been submitted to support the proposed change.



Public Input No. 91-NFPA 70-2023 [Section No. 422.5(A)]

(A) General.

Appliances identified in 422.5(A)(1) through (A)(7) 150 volts or less to ground and 60 amperes or less, single- or 3-phase, shall be provided with Class A protection for personnel. Multiple Class A protective devices shall be permitted but shall not be required.

- (1) Automotive vacuum machines
- (2) Drinking water coolers and bottle fill stations
- (3) Cord-and-plug-connected high-pressure spray washing machines
- (4) Tire inflation machines
- (5) Vending machines
- (6) Sump pumps
- (7) Dishwashers

Exception : GFCI protection shall not be required for appliances having ratings below the low-voltage contact limit

Informational Note: Section 210.8 specifies requirements for GFCI protection for the branch-circuit outlet where the covered location warrants such protection.

Additional Proposed Changes

<u>File Name</u>	<u>Description</u>	<u>Approved</u>
C0AAB35B-54CA-4E08-96EC-B07856CA8C3F.jpeg	low voltage sump pump	

Statement of Problem and Substantiation for Public Input

This exception is needed to allow low-voltage appliances to be installed without GFCI protection. Provisions similar to this exist throughout Article 680 allowing low-voltage swimming pool equipment to be installed without GFCI protection. I don't think low-voltage appliances are any more of a shock hazard than a low-voltage pool pump motor or low-voltage underwater swimming pool light. The pool pump and swimming pool light can be installed without GFCI protection per Article 680. Presently a 12-volt sump pump needs GFCI protection. This proposed exception provides needed relief for low-voltage appliances.

Related Public Inputs for This Document

<u>Related Input</u>	<u>Relationship</u>
<u>Public Input No. 90-NFPA 70-2023 [Section No. 210.8(D)]</u>	low voltage appliances

Submitter Information Verification

Submitter Full Name: Russ Leblanc
Organization: Leblanc Consulting Services
Street Address:
City:
State:

Zip:

Submittal Date: Wed Jan 11 09:26:57 EST 2023

Committee: NEC-P17

Committee Statement

Resolution: [FR-8871-NFPA 70-2024](#)

Statement: This section is editorially revised by creating sub-divisions (A), (B) and (C), including a charging statement. The permission for multiple GFCI devices is now in the charging statement and Class A is revised to the defined term acronym GFCI.

First level sub-division (A) is retitled to “circuit rating” to more accurately describe the requirements that follow. This sub-division is also revised to base the appliance GFCI protection on the branch circuit rating and not the rating of the appliance. The voltage and rating thresholds are put into list item form for clarity. A reference to the low voltage contact limit, a defined term in Article 100, is added to clarify that GFCI protection is not required when the branch circuit voltage is below the defined thresholds.

First level sub-division (B) is created for clarity and includes the appliances that require GFCI protection. List item (1) is revised to “branch-circuit overcurrent protective device” to correlate with the defined term in Article 100. An informational note is added to provide guidance to industry that an electrically cooled drinking water fountain is a type of water cooler. The existing informational note is revised to comply with the NEC Style Manual, Section 2.1.10.

Insufficient technical substantiation has been submitted to expand the list. Additionally, representatives for both UL 101 Leakage Current for Utilization Equipment and UL 943 GFCIs, as well as other industry stakeholders, are engaged in ongoing discussions concerning GFCI protection and appliance compatibility.

A time frame for compatibility within these product standards has not been established.

CMP 2 has purview of the branch circuit requirements in 210.8(D) and CMP 17 has purview over the requirements in 422.5.

Existing sub-division (B) is changed to (C) for editorial purposes.



**THE
BASEMENT
WATCHDOG®
Special #**

**Heavy Duty
Sump Pump**

12 VDC

- Submersible motor
- Not fit for use in oil, corrosive or flammable liquids

Part No. 1011002

Distributed by Glentronics, Inc., Lincolnshire, IL 60069



Public Input No. 98-NFPA 70-2023 [Section No. 422.5(A)]

(A) General.

Appliances identified in 422.5(A)(1) through (A)(7) supplied by branch circuits rated 150 volts or less to ground and 60 amperes or less, single- or 3-phase, shall be provided with Class A protection for personnel. Multiple Class A protective devices shall be permitted but shall not be required.

- (1) Automotive vacuum machines
- (2) Drinking water coolers and bottle fill stations
- (3) Cord-and-plug-connected high-pressure spray washing machines
- (4) Tire inflation machines
- (5) Vending machines
- (6) Sump pumps
- (7) Dishwashers

Informational Note: Section 210.8 specifies requirements for GFCI protection for the branch-circuit outlet where the covered location warrants such protection.

Statement of Problem and Substantiation for Public Input

This revision is needed to clarify that the branch circuit voltage matters! With the present wording the branch circuit voltage is completely irrelevant as it is never mentioned in this rule. Presently only the rating of the appliance matters. A 208V or 250V rated appliance installed on a branch circuit operating at 120V to ground is presently excluded based on the literal wording since the branch circuit operating voltage is not part of this requirement. I don't believe that the intent is to exclude this equipment.

Related Public Inputs for This Document

<u>Related Input</u>	<u>Relationship</u>
Public Input No. 29-NFPA 70-2023 [Section No. 210.8(D)]	branch circuit voltage vs appliance rated voltage

Submitter Information Verification

Submitter Full Name: Russ Leblanc
Organization: Leblanc Consulting Services
Street Address:
City:
State:
Zip:
Submittal Date: Wed Jan 11 11:28:58 EST 2023
Committee: NEC-P17

Committee Statement

Resolution: FR-8871-NFPA 70-2024

Statement: This section is editorially revised by creating sub-divisions (A), (B) and (C), including a charging statement. The permission for multiple GFCI devices is now in the charging statement and Class A is revised to the defined term acronym GFCI.

First level sub-division (A) is retitled to “circuit rating” to more accurately describe the requirements that follow. This sub-division is also revised to base the appliance GFCI protection on the branch circuit rating and not the rating of the appliance. The voltage and rating thresholds are put into list item form for clarity. A reference to the low voltage contact limit, a defined term in Article 100, is added to clarify that GFCI protection is not required when the branch circuit voltage is below the defined thresholds.

First level sub-division (B) is created for clarity and includes the appliances that require GFCI protection. List item (1) is revised to “branch-circuit overcurrent protective device” to correlate with the defined term in Article 100. An informational note is added to provide guidance to industry that an electrically cooled drinking water fountain is a type of water cooler. The existing informational note is revised to comply with the NEC Style Manual, Section 2.1.10.

Insufficient technical substantiation has been submitted to expand the list. Additionally, representatives for both UL 101 Leakage Current for Utilization Equipment and UL 943 GFCIs, as well as other industry stakeholders, are engaged in ongoing discussions concerning GFCI protection and appliance compatibility.

A time frame for compatibility within these product standards has not been established.

CMP 2 has purview of the branch circuit requirements in 210.8(D) and CMP 17 has purview over the requirements in 422.5.

Existing sub-division (B) is changed to (C) for editorial purposes.



Public Input No. 3730-NFPA 70-2023 [Section No. 422.6]

422.6– 2 Listing Required.

All appliances supplied by 50 volts or higher shall be listed.

Statement of Problem and Substantiation for Public Input

The section should be relocated to 422.2 for compliance with the NEC Style Manual Section 2.2.1.

Submitter Information Verification

Submitter Full Name: Derrick Atkins

Organization: Minneapolis Electrical JATC

Street Address:

City:

State:

Zip:

Submittal Date: Tue Sep 05 15:03:16 EDT 2023

Committee: NEC-P17

Committee Statement

Resolution: [FR-8837-NFPA 70-2024](#)

Statement: Listing requirements are relocated to 422.2 to comply with the NEC Style Manual Section 2.2.1.



Public Input No. 2685-NFPA 70-2023 [Section No. 422.10(A)]

(A) Individual Branch Circuits.

Individual branch circuits supplying appliances shall comply with the following as applicable:

- (1) The ampacities of branch-circuit conductors shall not be less than the marked rating of the appliance or the marked rating of an appliance having combined loads.
- (2) The ampacities of branch-circuit conductors for motor-operated appliances not having a marked rating shall be in accordance with ~~Part II of~~ Article 430 , Part II .
- (3) The branch-circuit rating for an appliance that is a continuous load, other than a motor-operated appliance, shall not be less than 125 percent of the marked rating, or not less than 100 percent of the marked rating if the branch-circuit device and its assembly are listed for continuous loading at 100 percent of its rating.
- (4) Branch circuits and branch-circuit conductors for household ranges and cooking appliances shall be permitted to be in accordance with Table 220.55 and shall be sized in accordance with 210.19(C).

Statement of Problem and Substantiation for Public Input

This Public Input is being submitted on behalf of the NEC Correlating Committee Usability Task Group in order to provide correlation throughout the document. The text is revised to to comply with the NEC Style Manual Section 4.1.4, regarding the use of Parts.

4.1.4 References to an Entire Article. References shall not be made to an entire article, except for the Article 100 or where referenced to provide the necessary context. References to specific parts within articles shall be permitted. References to all parts of an article shall not be permitted. The article number shall precede the part number.

The Usability Task Group members are: Derrick Atkins, David Hittinger, Richard Holub, Dean Hunter, Chad Kennedy and David Williams.

Submitter Information Verification

Submitter Full Name: David Williams

Organization: Delta Charter Township

Street Address:

City:

State:

Zip:

Submittal Date: Thu Aug 24 09:39:00 EDT 2023

Committee: NEC-P17

Committee Statement

Resolution: FR-8838-NFPA 70-2024

Statement: The text is revised to comply with the NEC Style Manual Section 4.1.4.



Public Input No. 3138-NFPA 70-2023 [Section No. 422.11(E)]

(E) Single Non-Motor-Operated Appliance.

If the branch circuit supplies a single non-motor-operated appliance, the rating of overcurrent protection shall comply with the following:

- (1) Not exceed the overcurrent protection rating marked on the appliance.
- (2) Not exceed 20 amperes if the overcurrent protection rating is not marked and the appliance is rated 13.3 amperes or less.
- (3) - ~~Not exceed 150 percent~~ 150 percent of the appliance rated current if the overcurrent protection rating is not marked and the appliance is rated over 13.3 amperes. Where 150 percent of the appliance rating does not correspond to a standard overcurrent device ampere rating, the next higher standard rating shall be permitted.

Statement of Problem and Substantiation for Public Input

Article 422.11 (E)(3) starts by stating (Not Exceed) then goes on to say if the 150 percent does not correspond to a standard overcurrent device ampere rating , the next higher standard rating shall be permitted .

If it cannot exceed 150 percent how can it go up.

This is confusing either 150 percent is the max or it is not.

Submitter Information Verification

Submitter Full Name: George Tidden

Organization: les Residential

Affiliation: IEC Gulf Coast

Street Address:

City:

State:

Zip:

Submittal Date: Tue Aug 29 15:44:57 EDT 2023

Committee: NEC-P17

Committee Statement

Resolution: List item three contains a maximum value, not an absolute value. By removing the text of "not exceed," the number becomes absolute. There are instances where 125% could be desired and should remain code compliant.



Public Input No. 2686-NFPA 70-2023 [Section No. 422.11(G)]

(G) Motor-Operated Appliances.

Motors of motor-operated appliances shall be provided with overload protection in accordance with ~~Part III of Article 430, Part III~~. Hermetic refrigerant motor-compressors in air-conditioning or refrigerating equipment shall be provided with overload protection in accordance with ~~Part VI of Article 440, Part VI~~. Where appliance overcurrent protective devices that are separate from the appliance are required, data for selection of these devices shall be marked on the appliance. The minimum marking shall be that specified in 430.7 and 440.4.

Statement of Problem and Substantiation for Public Input

This Public Input is being submitted on behalf of the NEC Correlating Committee Usability Task Group in order to provide correlation throughout the document. The text is revised to to comply with the NEC Style Manual Section 4.1.4, regarding the use of Parts.

4.1.4 References to an Entire Article. References shall not be made to an entire article, except for the Article 100 or where referenced to provide the necessary context. References to specific parts within articles shall be permitted. References to all parts of an article shall not be permitted. The article number shall precede the part number.

The Usability Task Group members are: Derrick Atkins, David Hittinger, Richard Holub, Dean Hunter, Chad Kennedy and David Williams.

Submitter Information Verification

Submitter Full Name: David Williams
Organization: Delta Charter Township
Street Address:
City:
State:
Zip:
Submittal Date: Thu Aug 24 09:40:07 EDT 2023
Committee: NEC-P17

Committee Statement

Resolution: [FR-8841-NFPA 70-2024](#)

Statement: The text is revised to comply with the NEC Style Manual Section 4.1.4.



Public Input No. 4421-NFPA 70-2023 [Section No. 422.11(G)]

~~(G) Motor-Operated Appliances:~~

~~Motors of motor-operated appliances shall be provided with overload protection in accordance with Part III of Article 430. Hermetic refrigerant motor compressors in air-conditioning or refrigerating equipment shall be provided with overload protection in accordance with Part VI of Article 440. Where appliance overcurrent protective devices that are separate from the appliance are required, data for selection of these devices shall be marked on the appliance. The minimum marking shall be that specified in 430.7 and 440.4.~~

Statement of Problem and Substantiation for Public Input

This section is not necessary as the requirements are already a part of other Articles as reference by this section. (Ref. 4.1.1 of the NEC Style manual)

Submitter Information Verification

Submitter Full Name: Thomas Domitrovich
Organization: Eaton Corporation
Street Address:
City:
State:
Zip:
Submittal Date: Thu Sep 07 14:55:41 EDT 2023
Committee: NEC-P17

Committee Statement

Resolution: CMP17 affirms the references enhance usability and are valuable to users of the Code. Although the text contains requirements from another article, it is the CMP's opinion that it does not violate 4.1.1 of the 2023 NEC Style Manual.



Public Input No. 1292-NFPA 70-2023 [Section No. 422.12]

422.12 Central Heating Equipment.

Central heating equipment other than fixed electric space-heating equipment shall be supplied by an individual branch circuit.

Exception No. 1: Auxiliary equipment, such as a pump, valve, humidifier, germicide irradiation luminaire, or electrostatic air cleaner directly associated with the heating equipment, shall be permitted to be connected to the same branch circuit.

Exception No. 2: Permanently connected air-conditioning equipment shall be permitted to be connected to the same branch circuit.

Additional Proposed Changes

<u>File Name</u>	<u>Description</u>	<u>Approved</u>
410.191_alt1.jpg		

Statement of Problem and Substantiation for Public Input

Germicide irradiation luminaires are typically installed in the plenum of a central heating system. The current required for them is quite low, and there is no reason to not allow them on the same circuit as the heating equipment. It can easily be argued that this exception already allows the practice, but as these systems gain in popularity arguments are sure to happen about the circuiting requirements.

Submitter Information Verification

Submitter Full Name: Ryan Jackson
Organization: Self-employed
Street Address:
City:
State:
Zip:
Submittal Date: Thu Jul 06 15:50:08 EDT 2023
Committee: NEC-P17

Committee Statement

Resolution: FR-8861-NFPA 70-2024

Statement: CMP 17 reaffirms that the requirements for central heating equipment are necessary to be retained in this article in order to provide specific installation requirements to industry.

The permission to connect other loads to the central heating equipment individual branch circuit in Exception No. 2 was expanded to include the receptacle required in 210.63(A) and the lighting outlet required in 210.70(C) as these loads would not typically overload an individual branch circuit.

In order to not continually expand the list, Exception No.1 was revised to include “similar equipment” which will permit equipment such as germicidal irradiation luminaires to be connected to the branch circuit.

410.191 Listing

© Ryan Jackson 2023



Luminaires that emit germicidal irradiation must be listed and be identified for germicidal irradiation.



Public Input No. 3467-NFPA 70-2023 [Section No. 422.12]

~~422.12~~ Central Heating Equipment:

~~Central heating equipment other than fixed electric space-heating equipment shall be supplied by an individual branch circuit.~~

~~Exception No. 1:- Auxiliary equipment, such as a pump, valve, humidifier, or electrostatic air cleaner directly associated with the heating equipment, shall be permitted to be connected to the same branch circuit.~~

~~Exception No. 2:- Permanently connected air-conditioning equipment shall be permitted to be connected to the same branch circuit.~~

Statement of Problem and Substantiation for Public Input

The requirement for an individual branch circuit for central heating equipment was first added to Article 422 in the 1990 edition of the NEC. See Proposal 10-5, Log # 2579 [n TCRA-1989 and Comments 10-2 & 10-1, Log numbers 2998 & 254 in TCDA-1989 for review of proposal, comments, and committee actions. This input includes the following substantiation to this section and requirement.

1. Proposal and comments for initial inclusion of this requirement identified the hazard as loss of heat and damage to a residence from potential freezing conditions in the structure while owners were away from home. While those conditions are not desirable, they are not electrical hazards as identified in the scope of the NEC.
2. Circuit overloading for circuits supplying central heating equipment other than fixed electric space-heating (the concern identified in initial proposal and comments for this requirement) is assumed to already be covered in Chapter 2.
3. This requirement covers "central heating equipment". That term is not defined. While most of us could likely explain our opinion of what equipment is covered by this requirement, we might determine in that discussion that opinions might vary significantly about which equipment is included.
4. While substantiation for the initial proposal and comments for this requirement seems to be limited to residential or senior citizen complexes, the NEC text was never limited to those occupancy types. If it was determined that ducted HVAC systems (central) using hot water coils or gas or other fuel in schools, retail space, businesses, health care, entertainment or other occupancy types were not fixed electric space-heating equipment, would this requiremnt be applicable?

Submitter Information Verification

Submitter Full Name: Donald Cook
Organization: Dewberry/Edmonds Engineering
Affiliation: self
Street Address:
City:
State:
Zip:
Submittal Date: Sun Sep 03 16:05:07 EDT 2023
Committee: NEC-P17

Committee Statement

Resolution: [FR-8861-NFPA 70-2024](#)

Statement: CMP 17 reaffirms that the requirements for central heating equipment are necessary to be retained in this article in order to provide specific installation requirements to industry.

The permission to connect other loads to the central heating equipment individual branch circuit in Exception No. 2 was expanded to include the receptacle required in 210.63(A) and the lighting outlet required in 210.70(C) as these loads would not typically overload an individual branch circuit.

In order to not continually expand the list, Exception No.1 was revised to include “similar equipment” which will permit equipment such as germicidal irradiation luminaires to be connected to the branch circuit.



Public Input No. 4108-NFPA 70-2023 [Section No. 422.12]

422.12 Central Heating Equipment.

~~Central heating equipment other than fixed electric space-heating equipment shall be supplied by an individual branch circuit.~~

~~Exception No. 1: Auxiliary equipment, such as a pump, valve, humidifier, or electrostatic air cleaner directly associated with the heating equipment, shall be permitted to be connected to the same branch circuit.~~

~~Exception No. 2: Permanently connected air-conditioning equipment shall be permitted to be connected to the same branch circuit.~~

An individual branch circuit shall be permitted to supply central heating equipment

Statement of Problem and Substantiation for Public Input

There is no definition for "Central heating equipment" but it is required to be on an individual branch circuit by section 422.12. The scope of Article 424 states "This article covers fixed electric equipment used for space heating. For the purpose of this article, heating equipment includes heating cables, unit heaters, boilers, central heating systems, or other fixed electric space-heating equipment. This article does not apply to process heating and room air conditioning." Why does section 422.12 make a distinction between central heating equipment and fixed electric space-heating equipment? Sections of 422.12 adds confusion and must be modified.

Submitter Information Verification

Submitter Full Name: Armando Lozano
Organization: MSF Electric, Inc.
Street Address:
City:
State:
Zip:
Submittal Date: Wed Sep 06 16:47:04 EDT 2023
Committee: NEC-P17

Committee Statement

Resolution: [FR-8861-NFPA 70-2024](#)

Statement: CMP 17 reaffirms that the requirements for central heating equipment are necessary to be retained in this article in order to provide specific installation requirements to industry.

The permission to connect other loads to the central heating equipment individual branch circuit in Exception No. 2 was expanded to include the receptacle required in 210.63(A) and the lighting outlet required in 210.70(C) as these loads would not typically overload an individual branch circuit.

In order to not continually expand the list, Exception No.1 was revised to include "similar equipment" which will permit equipment such as germicidal irradiation luminaires to be connected to the branch circuit.



Public Input No. 4424-NFPA 70-2023 [Section No. 422.12]

~~422.12~~ Central Heating Equipment:

~~Central heating equipment other than fixed electric space-heating equipment shall be supplied by an individual branch circuit.~~

~~*Exception No. 1: Auxiliary equipment, such as a pump, valve, humidifier, or electrostatic air cleaner directly associated with the heating equipment, shall be permitted to be connected to the same branch circuit.*~~

~~*Exception No. 2: Permanently connected air-conditioning equipment shall be permitted to be connected to the same branch circuit.*~~

Statement of Problem and Substantiation for Public Input

This requirement is more appropriately located in Article 440 and has been moved to that Article as part of a companion public input to this public input.

Submitter Information Verification

Submitter Full Name: Thomas Domitrovich
Organization: Eaton Corporation
Street Address:
City:
State:
Zip:
Submittal Date: Thu Sep 07 15:04:24 EDT 2023
Committee: NEC-P17

Committee Statement

Resolution: [FR-8861-NFPA 70-2024](#)

Statement: CMP 17 reaffirms that the requirements for central heating equipment are necessary to be retained in this article in order to provide specific installation requirements to industry.

The permission to connect other loads to the central heating equipment individual branch circuit in Exception No. 2 was expanded to include the receptacle required in 210.63(A) and the lighting outlet required in 210.70(C) as these loads would not typically overload an individual branch circuit.

In order to not continually expand the list, Exception No.1 was revised to include "similar equipment" which will permit equipment such as germicidal irradiation luminaires to be connected to the branch circuit.



Public Input No. 1295-NFPA 70-2023 [Section No. 422.13]

422.13 Storage-Type Water Heaters.

The rating of the branch-circuit overcurrent device and the ampacity of the conductors for fixed storage-type water heaters that have a capacity of 450 L (120 gal) or less shall ~~have an ampere rating of be~~ not less than 125 percent of the ampere rating of the water heater.

Informational Note: See 422.10 for branch-circuit rating.

Statement of Problem and Substantiation for Public Input

This editorial revision uses the term "ampacity" when referring to the conductors, as required by the style manual.

Submitter Information Verification

Submitter Full Name: Ryan Jackson

Organization: Self-employed

Street Address:

City:

State:

Zip:

Submittal Date: Thu Jul 06 15:57:06 EDT 2023

Committee: NEC-P17

Committee Statement

Resolution: [FR-8856-NFPA 70-2024](#)

Statement: This section was revised to clarify that the load is considered continuous. The text now applies to feeders, not just branch circuits, and recognizes 210.19, 210.20, 215.2 and 215.3 for conductor ampacity and overcurrent protective device rating.



Public Input No. 3266-NFPA 70-2023 [Section No. 422.13]

422.13 Storage-Type Water Heaters.

The branch-circuit overcurrent device ~~and conductors for ampere rating and the branch-circuit conductor ampacity for~~ fixed storage-type water heaters that have a capacity of 450 L (120 gal) or less shall ~~have an ampere rating of not be~~ less than 125 percent of the ampere rating of the water heater.

Informational Note: See 422.10 for branch-circuit rating.

Statement of Problem and Substantiation for Public Input

Conductors have an ampacity and overcurrent protective devices have an ampere rating. Making these edits to make those points clear in the requirement.

Submitter Information Verification

Submitter Full Name: Mike Holt

Organization: Mike Holt Enterprises Inc

Street Address:

City:

State:

Zip:

Submittal Date: Wed Aug 30 20:39:17 EDT 2023

Committee: NEC-P17

Committee Statement

Resolution: [FR-8856-NFPA 70-2024](#)

Statement: This section was revised to clarify that the load is considered continuous. The text now applies to feeders, not just branch circuits, and recognizes 210.19, 210.20, 215.2 and 215.3 for conductor ampacity and overcurrent protective device rating.



Public Input No. 741-NFPA 70-2023 [Section No. 422.13]

422.13 Storage-Type Water Heaters.

The branch-circuit overcurrent device and conductors for fixed storage-type water heaters that have a capacity of 450 L (120 gal) or less shall have an ampere rating of not less than 125 percent of the ampere rating of the water heater.

Exception: The installation in located in USDA plant hardiness zone 8a, IECC climate zone 3, or Energy Star climate zone South-Central (whichever is colder) or a warmer climate zone.

Informational Note: See 422.10 for branch-circuit rating.

Statement of Problem and Substantiation for Public Input

In warmer climates, such as the lower elevations of California (which is the nation's most populous state by far and where almost all people in the state live), the upper limit of what is considered a normal household's hot water usage will not cause a standard 40-to-50 US gallon (<120 US gallons) storage-type electric resistive/heat pump water heater to run for 3 or more hours, let alone 1 hour, continuously during the coldest months of January and February. A lot of codes in the US are based on the cold Northeast and Great Lakes because that is where most of the population has historically been centered on. The NEC defines a continuous load as expected to run at full load 3 or more hours continuously.

Abroad, the Canadian Electrical Code is more specific, defining that as 3 or more hours for any 6-hour period and 1 or more hours for any 2-hour period. Even under the more stringent Canadian Electrical Code definition, the storage type water heater in the metropolitan areas of California, Texas, Desert Southwest, and Southern states (where the cold water intake is warmer due to warmer winter temperatures) still isn't a continuous load. Besides, the ambient temperature is colder during winter, so the wires have extra ampacity compared to the standard 30 deg C.

As a result, a storage type electric water heater is definitely not a continuous load in warmer climates.

Submitter Information Verification

Submitter Full Name: Conrad Ko

Organization: [Not Specified]

Street Address:

City:

State:

Zip:

Submittal Date: Wed Apr 26 03:15:50 EDT 2023

Committee: NEC-P17

Committee Statement

Resolution: CMP17 reaffirms, notwithstanding weather conditions, that water heaters may operate for more than 3 hours. Insufficient technical substantiation has been submitted to support the proposed exception.



Public Input No. 2117-NFPA 70-2023 [Section No. 422.16(B)(1)]

(1) Electrically Operated In-Sink Waste Disposers.

Electrically operated in-sink waste disposers shall be permitted to be cord-and-plug-connected with a ~~flexible~~ power-supply cord identified as suitable in the installation instructions of the appliance manufacturer where all of the following conditions are met:

- (1) The length of the power-supply cord is not less than 450 mm (18 in.) and not exceeding 900 mm (36 in.).
- (2) Receptacles are located to protect against physical damage to the ~~flexible-cord~~ power-supply cord.
- (3) The receptacle is accessible.
- (4) The ~~flexible~~ power-supply cord has an equipment grounding conductor and is terminated with a grounding-type attachment plug.

Exception: A listed appliance distinctly marked to identify it as protected by a system of double insulation shall not be required to be terminated with a grounding-type attachment plug.

Statement of Problem and Substantiation for Public Input

A power-supply cord is a defined term in Article 100. This proposed change will make the language technically correct based on the Article 100 definition of "power-supply cord."

Submitter Information Verification

Submitter Full Name: Mike Holt

Organization: Mike Holt Enterprises Inc

Street Address:

City:

State:

Zip:

Submittal Date: Sat Aug 12 10:46:18 EDT 2023

Committee: NEC-P17

Committee Statement

Resolution: FR-8842-NFPA 70-2024

Statement: "Power-supply" is added to correlate with the existing defined term power-supply cord in Article 100.



Public Input No. 2118-NFPA 70-2023 [Section No. 422.16(B)(2)]

(2) Built-in Dishwashers and Trash Compactors.

Built-in dishwashers and trash compactors shall be permitted to be cord-and-plug-connected with a ~~flexible~~ power-supply cord identified as suitable for the purpose in the installation instructions of the appliance manufacturer where all of the following conditions are met:

- (1) For a trash compactor, the length of the power-supply cord is not less than 0.9 m (3 ft) and not exceeding 1.2 m (4 ft) measured from the face of the attachment plug to the plane of the rear of the appliance.
- (2) For a built-in dishwasher, the length of the power-supply cord is not less than 0.9 m (3 ft) and not exceeding 2.0 m (6.5 ft) measured from the face of the attachment plug to the plane of the rear of the appliance.
- (3) Receptacles are located to protect against physical damage to the ~~flexible~~ power-supply cord.
- (4) The receptacle for a trash compactor is located in the space occupied by the appliance or adjacent thereto. If a ~~flexible~~ power-supply cord passes through an opening, it shall be protected against damage by a bushing, grommet, smoothed edge, or other approved means.
- (5) The receptacle for a built-in dishwasher is located in the space adjacent to the space occupied by the dishwasher. If a ~~flexible~~ power-supply cord passes through an opening, it shall be protected against damage by a bushing, grommet, smoothed edge, or other approved means.
- (6) The receptacle is accessible.
- (7) The ~~flexible~~ power-supply cord has an equipment grounding conductor that is terminated with a grounding-type attachment plug.

Exception: A listed appliance distinctly marked to identify it as protected by a system of double insulation shall not be required to be terminated with a grounding-type attachment plug.

Statement of Problem and Substantiation for Public Input

A power-supply cord is a defined term in Article 100. This proposed change will make the language technically correct based on the Article 100 definition of "power-supply cord."

Submitter Information Verification

Submitter Full Name: Mike Holt
Organization: Mike Holt Enterprises Inc
Street Address:
City:
State:
Zip:
Submittal Date: Sat Aug 12 10:49:25 EDT 2023
Committee: NEC-P17

Committee Statement

Resolution: [FR-8844-NFPA 70-2024](#)

Statement: "Power-supply" is added to correlate with the existing defined term power-supply cord in Article 100



Public Input No. 2119-NFPA 70-2023 [Section No. 422.16(B)(3)]

(3) Wall-Mounted Ovens and Counter-Mounted Cooking Units.

Wall-mounted ovens and counter-mounted cooking units complete with provisions for mounting and for making electrical connections shall be permitted to be permanently connected or cord-and-plug-connected with a ~~flexible~~ power-supply cord identified as suitable for the purpose in the installation instructions of the appliance manufacturer.

A separable connector or a plug and receptacle combination in the supply line to an oven or cooking unit shall be identified for the temperature of the space in which it is located.

Statement of Problem and Substantiation for Public Input

A power-supply cord is a defined term in Article 100. This proposed change will make the language technically correct based on the Article 100 definition of "power-supply cord."

Submitter Information Verification

Submitter Full Name: Mike Holt

Organization: Mike Holt Enterprises Inc

Street Address:

City:

State:

Zip:

Submittal Date: Sat Aug 12 10:53:31 EDT 2023

Committee: NEC-P17

Committee Statement

Resolution: [FR-8847-NFPA 70-2024](#)

Statement: "Power-supply" is added to correlate with the existing defined term power-supply cord in Article 100.



Public Input No. 2234-NFPA 70-2023 [Section No. 422.16(B)(4)]

(4) Range Hoods and Microwave Oven/Range Hood Combinations.

Range hoods and over-the-range microwave ovens with integral range hoods shall be permitted to be cord-and-plug-connected with a flexible cord identified as suitable for use on range hoods in the installation instructions of the appliance manufacturer, where all of the following conditions are met:

- (1) The length of the cord is not less than 450 mm (18 in.) and not exceeding 1.2 m (4 ft).
- (2) Receptacles are located to protect against physical damage to the flexible cord.
- (3) The receptacle is supplied by an individual branch circuit.
- (4) The receptacle is accessible.
- (5) The receptacle is a single receptacle.
- (6) The flexible cord has an equipment grounding conductor and is terminated with a grounding-type attachment plug.

Exception: A listed appliance distinctly marked to identify it as protected by a system of double insulation shall not be required to be terminated with a grounding-type attachment plug.

Statement of Problem and Substantiation for Public Input

422.16 (B) (4) (3) - require the receptacle which is to be supplied by an individual branch circuit to be a single receptacle outlet. The change will help ensure that only the equipment outlined in 422.16 (B) (4) is connected to the receptacle, thereby helping to ensure that no other loads are supplied by the required individual branch circuit.

Article 100 defines an individual branch circuit as a branch circuit that supplies only one utilization equipment. Limiting 422.16 (B) (4) (3) to a single receptacle outlet will work to ensure the intent of the NEC more fully is realized. Current 422.16 (B) (4) code language does not preclude the installation of a duplex receptacle. The installation of a duplex receptacle on an individual branch circuit invites other loads to be connected to the individual branch circuit.

Submitter Information Verification

Submitter Full Name: Gary Hein

Organization: [Not Specified]

Street Address:

City:

State:

Zip:

Submittal Date: Tue Aug 15 12:42:42 EDT 2023

Committee: NEC-P17

Committee Statement

Resolution: The receptacle is typically installed in a location that reduces the likelihood of it being used for other purposes, so a single receptacle is not needed. A duplex receptacle is

permitted on an individual branch circuit, provided it does not supply other utilization equipment.



Public Input No. 2484-NFPA 70-2023 [Section No. 422.18]

422.18 Ceiling-Suspended (Paddle) Fans.

(A) Support.

Ceiling-suspended (paddle) fans shall be supported independently of an outlet box or by one of the following:

- (1) A listed outlet box or listed outlet box system identified for fan support installed in accordance with 314.27(C)
- (2) A listed outlet box system, a listed weight-supporting ceiling receptacle (WSCR), and a compatible factory-installed weight-supporting attachment fitting (WSAF) that is installed in accordance with 314.27(E)

Exception: In bedrooms of one- and two-family dwellings, ceiling mounted (paddle) fans shall be supported in accordance with both of the following:

(1) A listed outlet box or listed outlet box system identified for fan support installed in accordance with 314.27(C)

(2) A listed outlet box system, a listed WSCR, and a compatible factory installed WSAF that is installed in accordance with 314.27(E)

This exception shall become effective on January 1, 2027.

(B) Location.

No metal parts of ceiling-suspended (paddle) fans in bathrooms and shower spaces shall be located within a zone measured 900 mm (3 ft) horizontally and 2.5 m (8 ft) vertically from the top of the bathtub rim or shower stall threshold. This zone is all-encompassing and shall include the space directly over the tub or shower stall.

Additional Proposed Changes

<u>File Name</u>	<u>Description</u>	<u>Approved</u>
PI_2484_Update.pdf	Problems and Solutions Summary	
Data_PI_2484_Update.pdf	Data File for PI 2484	

Statement of Problem and Substantiation for Public Input

This public input proposes changes to enhance safety and simplify installation practices. This will improve worker safety during installation, maintenance, and replacement of luminaires. It will also make installations more robust and mechanically secure, ensuring a safer installation over the long term.

First of all, the text was revised by including the acronyms for the weight-supporting ceiling receptacle (WSCR) and weight-supporting attachment fitting (WSAF). This will provide consistency throughout the code. Secondly, a new exception was added to require the use of the WSCR and WSAF where there is a ceiling outlet box installed in the bedroom, with a future effective date.

EFFECTIVE DATE. The date was chosen to allow time for implementation by the industry, including depleting current inventory or inventory retrofitting.

STANDARD CONFIGURATION. This Public Comment follows the guidance provided by CMP 18 and

CMP 9 during the last code cycle. PI 3423 from the last cycle was resolved by CMP 18 with the following statement: “The lack of an industry standard configuration allows multiple configurations that can introduce complications if this rule shifts from permissible to mandatory.” Since then, three configurations for both the WSAF and WSCR were approved by NEMA for inclusion in ANSI/NEMA WD 6, “American National Standard for Wiring Devices - Dimensional Specifications.” These devices are designated in the standard as: WS3-50R, WS3-50AF for three poles; and WS3-70R, WS3-70AF for three poles, WS4-70R and WS4-70AF for four poles. These identifiers designate the special configuration of “weight-supporting” (“WS” prefix), the weight rating (50- or 70-pounds) and the application as a “receptacle” (“R” suffix) or the “attachment fitting” (“AF” suffix). The 50-pound configurations (“50” infix) are for the support of luminaires and the 70-pound configurations (“70” infix) are for the support of paddle fans. Informational notes for these new standard configurations in WD6 are now found following the definitions for WSCR and WSAF in Article 100.

INTERCHANGEABILITY. The WSCR has been determined to be compatible with all known ceiling outlet boxes. The WSCR (receptacle) for paddle fans (“70” infix) can accept the WSAF for either fans (“70” infix) or luminaires (“50” infix). The WSCR for luminaires is keyed so that it will only accept the WSAF for luminaires. The WSCR for paddle fans is a more robust receptacle, which is designed to support up to 70-pounds and the vibration from the dynamic load of a fan. The WSCR for luminaires is designed to support up to a 50-pound static luminaire load. The keyed luminaire receptacle will prevent the installation of the WSAF for heavier paddle fans. This video demonstrates the traditional installation of luminaires versus the installation using the WSCR <https://youtu.be/0idb9sOudi0?si=RwjhHB2E7S-woHJv>.

REDUCING THE HAZARD The WSCR reduces the hazard by simplifying installation and most importantly, eliminating the need to touch exposed conductors while installing ceiling-suspended (paddle) fans. Furthermore, installing ceiling-suspended (paddle) fans requires work on ladders and that, according to the CDC, falls are the leading cause of injuries. This is not just a problem for homeowners, it is also a problem for professionals. According to OSHA, falls are the leading cause of death in construction (see <https://www.osha.gov/stop-falls>), The use of ladders cannot be eliminated, but the simplified installation will reduce the time spent on ladders. It will also eliminate the need to juggle fixtures, while trying to make electrical connections. By engineering out the hazard, the human factors contributing to injuries or deaths are mitigated. The proposed changes to this section increase safety for the initial installation and for future exchanges of luminaires or ceiling-suspended (paddle) fans in one- and two-family dwellings. OSHA reports point to two professional electricians’ deaths that potentially could’ve been prevented by the use of WSCR. See the following links:

https://www.osha.gov/pls/imis/establishment.inspection_detail?id=18396960

https://www.osha.gov/pls/imis/establishment.inspection_detail?id=314163627 According to the American Housing Survey, which is a report generated every two years by the U.S. Census Bureau, a lot of home renovations are performed by the homeowner. Many homeowners are now installing their own ceiling-suspended (paddle) fans. Some hire professionals, but often the installer is not an electrical professional. The installer could be a painter, carpenter, drywaller or handy person. The data is in the supporting material included with this public input.

CONCLUSION

PUBLIC SAFETY. The WSCR and WSAF would improve public safety; a previously installed WSCR (female portion in the ceiling) will:

- REDUCE installation time and time on ladders (due to ease of installation)
- REDUCE time standing on something substituting for a ladder (chair, table, sofa, etc.)
- ELIMINATE homeowners splicing of wiring especially while on ladders
- REDUCE incorrect installations that could lead to fires or shock hazards
- REDUCE the number of falling luminaires and paddle fans
- REDUCE injuries and deaths from -- shock and electrocution – falls
- PROMOTE robust and safe first-time installation by professionals
- ALLOW quick connect for initial and future installations
- ELIMINATE straining of conductors and connectors holding the weight of luminaire during installation
- ELIMINATE the need to support the weight of the luminaire or ceiling paddle fan during wiring; the WSCR weighs ounces.
- FACILITATE safety because the inspector can verify the polarity of the wiring to the WSCR via a circuit tester (versus no polarity verification of luminaires/paddle fans currently)

ADDITIONAL BENEFITS TO MANUFACTURERS WHO LICENSE TECHNOLOGY. This submission

complies with the ANSI/NFPA Essential Patent Policy, and the necessary documentation has been provided to NFPA.

The WSCR and WSAF would benefit manufacturers as follows:

- REDUCE liability exposure
 - INCREASE purchasing of luminaires/paddle fans due to -- reduced installation costs -- ease of installation
 - INCREASE purchasing of different types or themed luminaires/paddle fans could be easily quick connected/disconnected based on events/holidays/formality
- DECREASE time get a certificate of occupancy once WSCR is installed in ceiling
- INCREASE purchasing of WSCR by homebuilders who wish to maximize spec homes (easy switch out of luminaires/paddle fans based on customer preference)
- REDUCE procrastination of remodeling (entire construction industry benefits)
- INCREASE interchangeability by promoting standardization
- INCREASED business - interchangeability that anyone's luminaire/paddle fan can be replaced with yours
 - DECREASE costs since multiple designs of connectors are not necessary
 - INCREASE product lines containing the "quick connect/disconnect" feature

This public input focuses on injury prevention. There are two categories of injuries that we are trying to prevent, those that can occur during installation and maintenance, and those that can happen subsequently, if a fixture falls. As noted in the supporting material entitled "Problems and Solutions Summary," falls are the leading cause of injury for the years 2001 through 2020 (see pages 32 and 33).

The Bureau of Labor Statistics reported on April 25, 2022 that

"Fatal injuries from ladders down in 2020; nonfatal ladder injuries were essentially unchanged In 2020, there were 161 fatal work injuries from which ladders were the primary source." The report also indicated that there were 171 death in 2019.

Nonfatal ladder injuries resulting in at least one day away from work were essentially unchanged in 2020. There were 22,710 injuries where the primary source of the injury was a ladder in 2020, compared with 22,330 in 2019. Installation, maintenance, and repair occupations had 5,790 injuries where the primary source was a ladder. Construction and extraction occupations had 5,370 ladder injuries, and service occupations had 3,160." (<https://www.bls.gov/opub/ted/2022/fatal-injuries-from-ladders-down-in-2020-nonfatal-ladder-injuries-were-essentially-unchanged.htm>)

It should be noted that there was a significant slow down in economic activity in 2020 due to the Covid 19 pandemic, which likely had an impact on ladder related injuries in the workplace.

According to the American Ladder Institute, as published on February 15, 2018 on the ANSI Blog: <https://blog.ansi.org/ali/common-causes-ladder-incidents/?amp=1>, the number 3 cause of ladder incidents is overreaching while on the ladder. This is common when installing luminaires and paddle fans.

The CPSC's National Electronic Injury Surveillance System (NEISS) contains numerous incidents involving injuries from ceiling fans, which is captured in the supporting material. This data comes from reports completed by hospital personnel who admit patients for treatment. It is important to note that this data comes from only 96 hospitals, that were selected by CPSC staff. There are 6,129 hospitals and an estimated 10,800 active urgent care clinics in the US. The document entitled "Relevant Incidents involving Ceiling (Paddle) Fans 2022-2013" reports on incidents where patient care was provided by one of those 96 hospitals. It is important to note that these incidents likely injuries caused by a falling fan. This is because NEISS reports on injuries caused by consumer products.

Falls are the most common of all injuries, but Incidents that occurred from falls during installation may not show up in this report, because they were not caused by the fan or luminaire. They were cause by a ladder safety issue. Many of the incidents involving ceiling fans are the result of improperly installed fans that have fallen on occupants. The WSCR for ceiling fans provides a safe and robust installation that includes a double-locking mechanism, along with an additional locking bracket to provide protection from the dynamic forces from the spinning fan motor.

Submitter Information Verification

Submitter Full Name: Mark Earley

Organization: Alumni Code Consulting

Affiliation: SKYX Platforms
Street Address:
City:
State:
Zip:
Submittal Date: Fri Aug 18 11:45:25 EDT 2023
Committee: NEC-P17

Committee Statement

Resolution: Existing text in the NEC already provides for use of a weight supporting ceiling receptacle or factory installed weight supporting fitting as an option, and not a required construction. Although these devices may improve safety and ease of installation, requiring these devices as the only method may restrict other options which are still in use and supported by manufacturers, installers and AHJs. CMP 17 reaffirms not including the proposed exception, see Public Comment 1136 from the 2023 NEC revision cycle.

PROBLEMS AND SOLUTIONS SUMMARY

Problem: Traditional wiring

Existing practices allow wiring of luminaires and paddle fans that can result in faulty installations or hazards that can include:

- Shocks, electrocutions, injuries & death
- Fires & shorts
- Exposure & contacting energized conductors
- Incorrect & sloppy wiring
- Splicing wires while on a ladder
- Straining of conductors & connectors holding the weight of luminaire during installation
- Incorrect installations go undetected
 - Loss of grounding/bonding connections
- Incorrect support causing luminaires/paddle fans to fall or damage wires
- Falls from ladders during installation from:
 - Shocks
 - Unsteadiness and losing balance
 - Awkwardness - handling while connecting wires

Solution: Weight Supporting Ceiling Receptacle (WSCR)

Plugging-in luminaires & paddle fans using the WSCR & Weight Supporting Attachment Fitting (WSAF) will eliminate and/or reduce risk of faulty wire installations and can:

- Reduce shocks, electrocutions, injuries & deaths
- Eliminate the need to touch wires; no exposed wires
- Prevent fires due to incorrect or sloppy wiring
- Provide a means to check polarity
- Eliminate straining of conductors & connectors holding the weight of luminaire during installation
- Eliminate splicing wires while on a ladder
- Reduce majority of time on ladders (unsteadiness & losing balance)
- Reduce awkwardness of handling luminaires/paddle fans while connecting wires

Supporting Data for Public Input

REQUIREMENTS FOR WEIGHT SUPPORTING CEILING RECEPTACLE
(WSCR) AND WEIGHT SUPPORTING ATTACHMENT FITTING (WSAF)

*formerly Locking Support and Mounting Receptacle and
Attachment Fitting*

Table of Contents

Do It Yourselfers.....	1
Renovation Statistics.....	1
Home Improvement DIY vs Professional Percentages, 2011 through 2017.....	2
Electrical Home Improvement Projects.....	3
NFPA Residential Fire Statistics.....	3
Injury Reports.....	5
OSHA Reports.....	5
NIOSH Reports.....	5
CPSC Statistics.....	6
CDC Data.....	6
Annex A: Home Renovations Reported in the American Housing Survey.....	8
2015-2016 DIY vs Professional by Renovation Type.....	8
2013-2014 DIY vs Professional by Renovation Type.....	14
2011-2012 DIY vs Professional by Renovation Type.....	20
2009-2010 DIY vs Professional by Renovation Type.....	26
Annex B: CDC Injury Data.....	32
Fall Deaths, 2001-2017.....	32
10 Leading Causes of Nonfatal ER Visits, 2001-2017.....	33

MANY DIY'ERS MAKE THIS TECHNOLOGY CRUCIAL FOR SAFETY

Large Support Network for Do It Yourselfers

There is a significant market for do-it-yourself home improvement. Big-box retailers have sprung up across North America that supply products directly to the consumer. There are 2,286 North American Home Depot stores, 2155 Lowe's Stores, 5000 Ace Hardware stores, 3800 True Value stores, 4500 Do it Best stores, 1000 Harbor Freight stores and others that supply inexpensive tools to many of the DIYers. The DIY market is also supported by all sorts of You Tube videos, some of which is vendor supported, but much of which is generated by someone who may not be an expert. In addition, the Home and Garden TV Network (HGTV) has convinced many that they can make large profits by buying distressed existing home and flipping them. This has also encouraged homeowners to improve their own homes.

The big box stores are known for having large lighting departments that have extensive displays of fixtures. Many can arrange for a local contractor to do the installation. However, many consumers are taking on the project themselves or having some unlicensed handyman do the installation work.

The public inputs will propose to require that lighting outlets utilize listed WSCR and WSAF (locking support-type receptacles to connect to compatible attachment fittings) on luminaires and paddle fans. The use of the WSCR and WSAF simplify the replacement of luminaires and paddle fans. The use of the WSCR and WSAF limits the exposure to energized parts for future fixture replacements. Falls from ladders are a safety problem for professionals in the workplace. They are also a safety problem in the home. Simplifying the replacement process limits the time spent on ladders, and reduces the extended reach from higher ladder steps, minimizing the number of falls.

Fixtures have varying degrees of installation complexity and a variety of fastening means. There is also a lot of variety of degrees of assembly that is required. Some of assembly might take place on the ladder. With WSCR and WSAF, all of the assembly can take place off the ladder and the completed assembly can simply be raised into position and plugged in.

Renovation Statistics

The American Housing Survey, produced by the Census Bureau is generated every two years¹. One of the many factors analyzed is home renovations. The survey analyzes professional and DIY renovations. The statistics appear to show a level percentage of DIY renovations out of the total number of renovations for each reporting period. Some renovations can easily be

¹ U. S. Census Bureau, *American Housing Survey*. (n.d.). Retrieved July 20, 2020, from https://www.census.gov/programs-surveys/ahs/data/interactive/ahstablecreator.html?s_areas=00000&s_year=2011&s_tablename=TABLE16&s_bygroup1=24&s_bygroup2=1&s_filtergroup1=1&s_filtergroup2=1.

performed by the homeowner. Surprisingly, the statistics also show a fairly consistent percentage of electrical renovations that are DIY. Permits are rarely taken out for DIY equipment replacements or renovations. That is sometimes the case with flipped homes. As a result, DIY work is rarely inspected by jurisdictional electrical inspectors. Even when permits are taken out, there is no guarantee that the work will be performed by professionals or that it will be inspected. Many jurisdictions will only spot check the work of homeowners because inspections cost money and if there is no inspection, the jurisdiction can just collect the permit fee. For those who are classified as professional, how many of the practitioners are electricians? How many are just handymen? Figures 1 through 4 illustrate the percentages of home improvement projects for a two-year period ending in 2017, 2015, 2013, and 2011. Figure 5 illustrates all of the electrical home improvement projects reported by the survey from 2010 through 2017. The background data is in Annex A.

FIGURES 1-4: LARGE PERCENTAGE OF HOME IMPROVEMENTS DONE BY DIY'ers; "PROFESSIONALS" CAN INCLUDE PAINTERS AND HANDYMEN, NOT ALWAYS ELECTRICIANS.

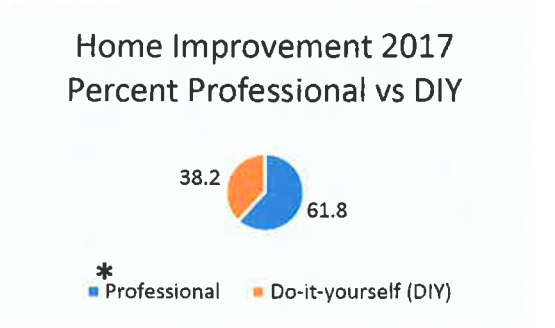

Figure 1.

* Professionals include handyman/painters/electricians

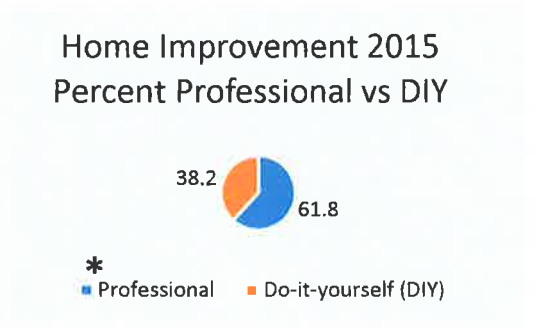

Figure 2.

* Professionals include handyman/painters/electricians

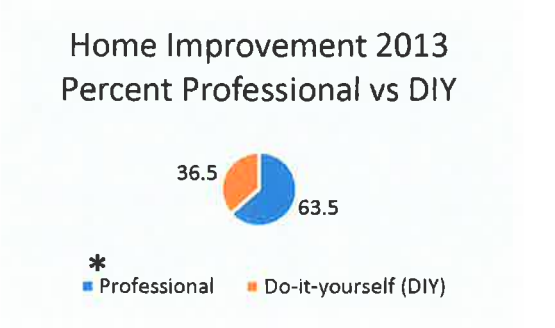

Figure 3.

* Professionals include handyman/painters/electricians

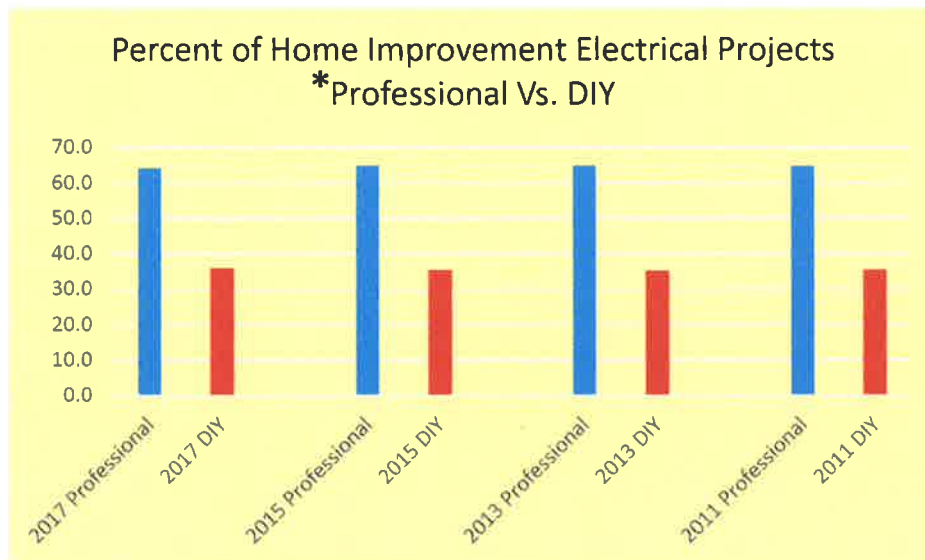

Figure 4.

* Professionals include handyman/painters/electricians

Electrical Home Improvement Projects

The number of people who are willing to do electrical work themselves has been a similar percentage to that of all DIY projects. It has also remained steady over the study periods of the survey. The raw statistics are included to provide a clearer picture of the types of home improvement projects undertaken. Many of the interior renovations likely include some electrical work, which may or may not be included separately as electrical work.



* Professionals include handyman/painters/electricians

Figure 5.

NFPA Residential Fire Statistics

NFPA estimates that 17,600 home fires in the US that are caused by faulty wiring connected with ceiling fans and lights (<https://www.nfpa.org/-/media/Files/News-and-Research/Fire-statistics-and-reports/Building-and-life-safety/oshomes.pdf>) The report notes "Electrical distribution or lighting equipment was the leading cause of home fire property damage. An average of 35,000 such fires caused 500 deaths; 1,130 injuries; and \$1.4 billion in direct property damage per year. Wiring and related equipment accounted for 7 percent of all home fires and 10 percent of all home fire deaths. Cords or plugs were involved in only 1 percent of the fires but 6 percent of the deaths. Extension cords dominated the cord or plug category. More information is available in the NFPA report, *Electrical Fires*²."

² Campbell, R. (2019, March). *Electrical Fires* (Tech.). Retrieved July 20, 2020, from National Fire Protection Association website: <https://www.nfpa.org/News-and-Research/Data-research-and-tools/Electrical/Electrical>

The following table notes fire statistics for lighting and distribution equipment. This is a rather broad category. There is a separate category for ceiling fans. It appears that fans category includes bathroom vent fans. It may also include kitchen exhaust fans.

Table 5.
Home Fires Involving Electrical Failure or Malfunction as Factor Contributing to Ignition
by Equipment Involved in Ignition, 2012-2016 Annual Averages

Equipment Involved	Fires		Civilian Deaths		Civilian Injuries		Direct Property Damage (in Millions)	
Electrical distribution and lighting equipment	22,620	(50%)	310	(71%)	700	(56%)	\$786	(62%)
Wiring and related equipment	17,600	(39%)	190	(43%)	440	(35%)	\$588	(46%)
Cord or plug	2,080	(5%)	100	(23%)	130	(11%)	\$85	(7%)
Lamp, bulb or lighting	1,850	(4%)	10	(3%)	70	(5%)	\$64	(5%)
Transformers and power supplies	1,080	(2%)	10	(2%)	60	(5%)	\$49	(4%)

Later on, NFPA's *Electrical Fires* report contains the following table, which, for the same time period has different and larger numbers:

Table 14.
Home Fires Involving Electrical Distribution and Lighting Equipment, by Equipment Involved in Ignition
2012-2016 Annual Averages

Equipment Involved	Fires		Civilian Deaths		Civilian Injuries		Direct Property Damage (in Millions)	
Wiring and related equipment	24,780	(67%)	270	(55%)	640	(53%)	\$853	(67%)
Lamp, bulb or lighting	4,970	(13%)	40	(9%)	200	(17%)	\$164	(13%)
Cord or plug	3,330	(11%)	160	(33%)	230	(19%)	\$143	(11%)
Transformers and power supplies	2,060	(9%)	20	(3%)	130	(11%)	\$108	(9%)
Other known equipment involved in ignition	20	(0%)	0	(0%)	0	(0%)	\$0	(0%)
Total	35,150	(100%)	490	(100%)	1,200	(100%)	\$1,270	(100%)

Injury Reports

OSHA Reports. Falls from ladders are a frequent hazard. They happen in commercial and industrial settings as well as in residential situations. For example: in the OSHA electrocution training materials, an OSHA Fatal Fact is presented³ that details a union electrician's death by electrocution during trouble shooting with lamps. The shock caused the electrician to fall off the ladder (OSHA Incident Report #0418800).⁴

Another example: in 2011, an electrician was electrocuted when the wires of a light fixture he was attempting to hang became stripped energizing the light fixture. As he grabbed one of the attached steel hanging cables, he received a fatal shock (OSHA Incident Report #0317700).⁵ It is reasonable to conclude that this incident could have been avoided if the new technology receptacle/attachment fitting technology had been used because the fixture could not have become energized, as there would be no access to electricity through the disconnected fixture.

NIOSH Reports. The National Institute for Occupational Safety and Health (NIOSH) conducts the Fatal Accident Circumstances and Epidemiology (FACE) Project. Data are collected from a sample of fatal accidents, including electrical-related fatalities.

For example: NIOSH FACE Report 87-55⁶ summarized a 1987 electrocution of a North Carolina electrician. While repairing a fluorescent light fixture over a kitchen sink in a single-family residence, a 33-year-old journeyman electrician was electrocuted when he contacted an energized wire on the load side of the ballast (400 volts). The ballast had been replaced. However, he could not get the light to operate properly. The electrician was sitting on the sink when he apparently contacted an energized wire on the load side of the ballast. The circuit had not been de-energized at the panel box or at the single-pole switch on the wall beside the sink.

It is reasonable to conclude that this incident might have been avoided if the WSCR/WSAF technology had been used. The receptacle would've already been installed, and the fixture could've been taken down through a simple quick disconnect for examination. If the fixture was determined to be in working order, additional work could be completed with the fixture

³ Construction Focus Four: Electrocution Hazards, Instructor Guide. OSHA Training Institute, OSHA Directorate of Training and Education, April 2011. Document can be found online at https://www.osha.gov/dte/outreach/construction/focus_four/electrocution/electr_ig.pdf

⁴ OSHA Report ID: 0418800 can be found at https://www.osha.gov/pls/imis/establishment.inspection_detail?id=18396960

⁵ OSHA Report ID: 0317700 can be found at https://www.osha.gov/pls/imis/establishment.inspection_detail?id=314163627⁶ NIOSH Face Reports 1982 to 2005 including 87-55 can be found at http://wwwn.cdc.gov/NIOSH-FACE/Default.cshtml?state=ALL&Incident_Year=ALL&Category2=0006&Submit=Submit#.VFjs8y7-DK0.email. This particular report can be located directly at <http://www.cdc.gov/niosh/face/In-house/full8755.html>

⁶ NIOSH Face Reports 1982 to 2005 including 87-55 can be found at http://wwwn.cdc.gov/NIOSH-FACE/Default.cshtml?state=ALL&Incident_Year=ALL&Category2=0006&Submit=Submit#.VFjs8y7-DK0.email. This particular report can be located directly at <http://www.cdc.gov/niosh/face/In-house/full8755.html>

⁷ 2004 Electrocutions Associated with Consumer Products, By Matthew V. Hnatov. Hazard Analysis Division, Directorate for Epidemiology, Consumer Products Safety Commission. April 2009

quickly disconnected and out of the vicinity so full attention could be given to the wiring. If the new technology had been used, the electrocution might have been avoided.

CPSC Data. It is important to note that CPSC data includes only the data the CPSC becomes aware of, and it is understood that there are many other incidents that are not reported or do not come to their attention. Consumers are not obligated to report incidents to the CPSC. The research from the National Electronic Injury Surveillance System (NEISS) database from 2009 to 2013 included the following:

- CPSC estimates 4 electrocution deaths per year associated with lighting products.⁷
- There were 38 incidents involving the installation of light fixtures that resulted in hospital emergency room visits;
- 32 of those incidents involved falls and at least four of those incidents involved the victims being shocked.

With the new technology, after the receptacle is installed in the ceiling, there is no additional wiring necessary, no weight or bulk of the fixture during the initial receptacle installation, certainty of connection of the fixture to the equipment grounding conductor, and no shock hazard during the quick connect of the fixture. Without the weight/bulk, the falls may not have occurred. With the new technology receptacle in place, installation of the luminaire is a quick connect and no shock would have occurred.

- There were 418 incidents involving changing light bulbs that resulted in hospital emergency room visits;
- 390 involved falls and at least six of those incidents involved the victims being shocked.
- There were 9 additional incidents associated with cleaning the light fixture that resulted in hospital emergency room visits; 8 of those involved falls.

Many of these incidents could have been avoided or minimized if the new technology receptacle/attachment fitting technology had been used. The fixture is simply disconnected and any bulb or fixture maintenance or cleaning can be done on a table, not at an elevation, thereby reducing the time at an elevated level, thereby reducing the hazard.

- There were 55 incidents involving a luminaire falling from the ceiling onto the victim that resulted in hospital emergency room visits.

If the receptacle/attachment fitting (WSCR/WSAF) technology had been used, many of these incidents could have been avoided or minimized. The new technology must pass weight support requirements in the UL product safety standards well beyond what the NEC permits.

⁷ 2004 Electrocutions Associated with Consumer Products, By Matthew V. Hnatov. Hazard Analysis Division, Directorate for Epidemiology, Consumer Products Safety Commission. April 2009

The NEC does not permit the assembly to support a luminaire weighing more than 50 lbs or a ceiling fan weighing more than 70 lbs, therefore the fixtures would not fall.

CDC Data. According to the Centers for Disease Control and Prevention (CDC), falls are the number one cause of injury. From 2001-2017, there were 144,895,242 falls reported to CDC. During the same period, there were 443,576 deaths from falls. It is not unreasonable to assume that many of these falls involved working on a luminaire. Ladder related accidents are common. In addition, some will resort to stools, chairs, and chairs with boxes or books on them to get to the right height. Detailed information can be found in Annex B. There is little information on what the victims were doing when they fell.

In 1997, Industrial Safety and Hygiene News (ISHN) noted “According the American Academy of Orthopedic Surgeons, every year 500,000 people are treated for ladder-related injuries and approximately 300 of these incidents prove to be fatal. The Liberty Mutual Research Institute for Safety found that in 2007 alone, more than 400 people died as a result of falls on or from ladders or scaffolding⁸.

Summary

When viewing data contained in the Annexes, it is important to note that there is no way to know the exact number of improper installations. For example, if there were one million annual installations of luminaires (it could be argued that there are significantly *more* annual installations per Annex A) and just 2% of them were improperly installed by an untrained do-it-yourselfers, that would result in 20,000 improperly installed luminaires.

⁸ 500,000 Falls from Ladders Annually; 97 Percent Occur at Home or on Farms. (July 6, 2017). *Industrial Safety and Hygiene News*. Retrieved July 20, 2020, from <https://www.ishn.com/articles/106830-000-falls-from-ladders-annually-97-percent-occur-at-home-or-on-farms>

Annex A. Home Renovations Reported in the American Housing Survey

Survey Notes: Estimates and Margins of Error in thousands of housing units, except as indicated. Medians are rounded to four significant digits as part of disclosure avoidance protocol. Margin of Error is calculated at the 90% confidence interval. Weighting consistent with Census 2010. Blank cells represent zero; Z rounds to zero; '.' Represents not applicable or no cases in sample; S represents estimates that did not meet publication standards or withheld to avoid disclosure.

Characteristics	Professional/Do- It-Yourself Total Estimate	Professional Estimate	Do-It-Yourself Estimate
HOME IMPROVEMENT ACTIVITY IN LAST TWO YEARS (2017)			
Total			
Number of projects (1,000)	113,155	69,975	43,181
Median expenditures (\$)	1,364	2,408	600
Total expenditures (1,000)	450,089,818	368,366,827	81,722,991
Disaster Repairs.			
Earthquake			
Number of projects (1,000)	S	S	S
Median expenditures (\$)	S	S	300
Total expenditures (1,000)	S	S	S
Tornado/hurricane			
Number of projects (1,000)	418	303	115
Median expenditures (\$)	7,000	7,000	S
Total expenditures (1,000)	4,490,105	3,276,862	S
Landslide			
Number of projects (1,000)	S	S	.
Median expenditures (\$)	6,020	6,020	.
Total expenditures (1,000)	S	S	.
Fire			

Number of projects (1,000)	113	85	S
Median expenditures (\$)	10,000	10,000	S
Total expenditures (1,000)	S	S	S
Flood			
Number of projects (1,000)	197	121	76
Median expenditures (\$)	S	13,500	S
Total expenditures (1,000)	5,283,698	S	S
Other			
Number of projects (1,000)	867	734	133
Median expenditures (\$)	9,500	10,500	3,800
Total expenditures (1,000)	10,898,601	10,190,039	708,562
Room Additions and Renovations.			
Bedroom			
Number of projects (1,000)	419	184	235
Median expenditures (\$)	7,000	23,000	2,000
Total expenditures (1,000)	7,289,971	6,000,692	1,289,280
Bath			
Number of projects (1,000)	274	162	112
Median expenditures (\$)	6,400	10,000	4,000
Total expenditures (1,000)	3,258,882	2,493,137	765,746
Recreation Room			
Number of projects (1,000)	196	105	91
Median expenditures (\$)	S	24,000	3,750
Total expenditures (1,000)	4,880,565	3,875,457	S
Kitchen			
Number of projects (1,000)	159	94	65
Median expenditures (\$)	S	30,000	S
Total expenditures (1,000)	4,559,506	3,686,182	S
Other			

Number of projects (1,000)	827	444	383
Median expenditures (\$)	6,500	12,500	S
Total expenditures (1,000)	13,508,584	11,125,843	2,382,741

Remodeling.

Bath

Number of projects (1,000)	5,739	3,001	2,738
Median expenditures (\$)	3,000	5,250	1,500
Total expenditures (1,000)	35,305,520	26,856,855	8,448,665

Kitchen

Number of projects (1,000)	4,184	2,358	1,826
Median expenditures (\$)	6,000	10,000	3,000
Total expenditures (1,000)	49,553,906	37,772,420	11,781,486

Exterior Additions and Replacements.

Attached garage/carport

Number of projects (1,000)	736	389	347
Median expenditures (\$)	2,800	4,500	2,200
Total expenditures (1,000)	6,120,015	4,365,016	1,754,999

Porch/deck/patio/terrace

Number of projects (1,000)	3,331	1,798	1,533
Median expenditures (\$)	2,500	4,400	1,000
Total expenditures (1,000)	18,805,519	14,757,663	4,047,856

Roofing

Number of projects (1,000)	6,766	5,656	1,110
Median expenditures (\$)	6,000	6,800	2,200
Total expenditures (1,000)	50,222,041	45,937,650	4,284,391

Siding

Number of projects (1,000)	1,937	1,264	672
Median expenditures (\$)	3,000	4,800	920

Total expenditures (1,000)	9,468,686	8,030,873	1,437,813
Windows/doors			
Number of projects (1,000)	7,443	4,799	2,644
Median expenditures (\$)	1,400	2,300	500
Total expenditures (1,000)	24,777,309	21,119,910	3,657,399
Chimney/stairs/other exterior additions			
Number of projects (1,000)	1,531	1,087	444
Median expenditures (\$)	1,072	1,440	480
Total expenditures (1,000)	3,856,308	3,133,861	722,448
Interior Additions and Replacements			
Insulation			
Number of projects (1,000)	2,712	1,451	1,261
Median expenditures (\$)	750	1,250	400
Total expenditures (1,000)	3,886,216	2,948,857	937,359
Water pipes			
Number of projects (1,000)	3,014	1,792	1,221
Median expenditures (\$)	550	1,000	200
Total expenditures (1,000)	4,549,002	3,972,440	576,562
Plumbing fixtures			
Number of projects (1,000)	8,192	3,924	4,268
Median expenditures (\$)	400	700	250
Total expenditures (1,000)	10,766,188	8,227,445	2,538,743
Electrical wiring/fuse boxes/breaker switches			
Number of projects (1,000)	4,487	2,879	1,609
Median expenditures (\$)	600	1,000	300
Total expenditures (1,000)	6,388,526	5,088,660	1,299,866
Security system			
Number of projects (1,000)	4,286	2,933	1,353

Median expenditures (\$)	400	400	400
Total expenditures (1,000)	2,605,279	1,732,909	872,370
Flooring/carpeting/paneling/ceiling tiles			
Number of projects (1,000)	10,438	6,364	4,074
Median expenditures (\$)	2,000	2,875	920
Total expenditures (1,000)	33,135,645	26,515,795	6,619,850
HVAC			
Number of projects (1,000)	9,930	8,571	1,359
Median expenditures (\$)	3,600	4,000	2,000
Total expenditures (1,000)	43,413,330	39,616,745	3,796,585
Septic tank			
Number of projects (1,000)	355	300	55
Median expenditures (\$)	3,000	3,000	S
Total expenditures (1,000)	1,474,779	1,387,439	S
Water heater/dishwasher/garbage disposal			
Number of projects (1,000)	14,569	8,457	6,113
Median expenditures (\$)	500	700	400
Total expenditures (1,000)	10,813,487	7,882,752	2,930,735
Other interior			
Number of projects (1,000)	1,901	1,250	651
Median expenditures (\$)	1,700	2,143	1,000
Total expenditures (1,000)	S	S	1,348,948
Lot or Yard Additions & Replacements.			
Driveways/walkways			
Number of projects (1,000)	3,858	2,627	1,231
Median expenditures (\$)	1,800	2,640	550
Total expenditures (1,000)	12,015,598	10,545,199	1,470,399
Fencing/walls			

Number of projects (1,000)	4,449	2,303	2,146
Median expenditures (\$)	1,300	2,600	601
Total expenditures (1,000)	10,140,802	7,603,533	2,537,269
Swimming pool/tennis court/recreational structures			
Number of projects (1,000)	967	537	431
Median expenditures (\$)	3,500	7,500	748
Total expenditures (1,000)	11,131,910	10,170,999	960,911
Shed/detached garage/other building			
Number of projects (1,000)	2,337	1,095	1,243
Median expenditures (\$)	2,000	3,100	1,000
Total expenditures (1,000)	11,680,657	7,570,385	4,110,272
Landscaping/sprinkler system			
Number of projects (1,000)	5,541	2,279	3,262
Median expenditures (\$)	900	2,000	500
Total expenditures (1,000)	13,390,741	9,353,303	4,037,438
Other			
Number of projects (1,000)	964	612	352
Median expenditures (\$)	2,000	3,000	500
Total expenditures (1,000)	4,583,936	4,169,719	414,217

Characteristics	Professional/Do-it-Yourself		
	Total Estimate	Professional Estimate	Do-it-Yourself Estimate
HOME IMPROVEMENT ACTIVITY IN LAST TWO YEARS (2015)			
Total			
Number of projects (1,000)	123,481	76,277	47,204
Median expenditures (\$)	1,200	2,000	600
Total expenditures (1,000)	431,497,494	347,110,853	84,386,641
Disaster Repairs.			
Earthquake			
Number of projects (1,000)	23	13	S
Median expenditures (\$)	S	S	S
Total expenditures (1,000)	194,698	172,620	S
Tornado/hurricane			
Number of projects (1,000)	339	263	76
Median expenditures (\$)	6,000	7,000	S
Total expenditures (1,000)	3,171,864	2,692,720	S
Lightning/fire			
Number of projects (1,000)	142	92	50
Median expenditures (\$)	S	S	S
Total expenditures (1,000)	5,161,751	S	S
Flood			
Number of projects (1,000)	211	139	72
Median expenditures (\$)	8,150	8,685	S
Total expenditures (1,000)	2,999,016	S	S
Other			
Number of projects (1,000)	823	708	115

Median expenditures (\$)	8,550	9,000	3,000
Total expenditures (1,000)	10,029,780	9,309,961	S

Room Additions and Renovations.

Bedroom

Number of projects (1,000)	516	259	257
Median expenditures (\$)	5,000	17,000	2,000
Total expenditures (1,000)	10,997,017	8,903,760	2,093,257

Bath

Number of projects (1,000)	303	162	141
Median expenditures (\$)	S	10,000	2,500
Total expenditures (1,000)	3,463,143	2,847,832	615,311

Recreation Room

Number of projects (1,000)	253	124	130
Median expenditures (\$)	S	15,000	2,800
Total expenditures (1,000)	3,036,052	2,510,855	525,197

Kitchen

Number of projects (1,000)	198	133	65
Median expenditures (\$)	12,110	15,000	5,000
Total expenditures (1,000)	4,355,845	3,925,883	S

Other

Number of projects (1,000)	861	453	408
Median expenditures (\$)	5,000	8,000	2,000
Total expenditures (1,000)	9,920,768	7,905,575	2,015,193

Remodeling.

Bath

Number of projects (1,000)	6,547	3,406	3,141
Median expenditures (\$)	3,000	5,000	1,500
Total expenditures (1,000)	37,537,408	28,304,879	9,232,529

Kitchen			
Number of projects (1,000)	4,740	2,595	2,145
Median expenditures (\$)	5,000	7,000	3,000
Total expenditures (1,000)	47,380,831	34,471,023	12,909,808
Exterior Additions and Replacements.			
Attached garage/carport			
Number of projects (1,000)	717	403	314
Median expenditures (\$)	4,000	5,000	2,500
Total expenditures (1,000)	5,304,691	3,745,563	1,559,127
Porch/deck/patio/terrace			
Number of projects (1,000)	3,616	1,953	1,663
Median expenditures (\$)	2,500	4,000	1,200
Total expenditures (1,000)	18,899,196	14,824,455	4,074,741
Roofing			
Number of projects (1,000)	8,035	6,543	1,492
Median expenditures (\$)	5,500	6,000	2,500
Total expenditures (1,000)	52,948,893	47,088,310	5,860,584
Siding			
Number of projects (1,000)	2,275	1,607	667
Median expenditures (\$)	3,000	4,000	1,000
Total expenditures (1,000)	12,524,667	10,787,609	1,737,057
Windows/doors			
Number of projects (1,000)	8,693	5,580	3,114
Median expenditures (\$)	1,500	2,000	600
Total expenditures (1,000)	27,257,002	22,199,593	5,057,410
Chimney/stairs/other exterior additions			
Number of projects (1,000)	1,479	983	496
Median expenditures (\$)	1,050	1,500	450
Total expenditures (1,000)	3,427,485	2,944,792	482,694

Interior Additions and Replacements.**Insulation**

Number of projects (1,000)	3,531	1,862	1,669
Median expenditures (\$)	750	1,200	400
Total expenditures (1,000)	4,991,329	3,779,128	1,212,201

Water pipes

Number of projects (1,000)	3,540	2,080	1,461
Median expenditures (\$)	500	900	200
Total expenditures (1,000)	5,259,795	4,233,234	1,026,561

Plumbing fixtures

Number of projects (1,000)	9,116	4,313	4,804
Median expenditures (\$)	400	550	250
Total expenditures (1,000)	9,667,129	6,882,298	2,784,831

Electrical wiring/fuse boxes/breaker switches

Number of projects (1,000)	5,018	3,249	1,769
Median expenditures (\$)	600	916	240
Total expenditures (1,000)	7,302,161	6,141,821	1,160,340

Security system

Number of projects (1,000)	3,707	2,943	764
Median expenditures (\$)	350	300	400
Total expenditures (1,000)	2,194,706	1,705,733	488,973

Flooring/carpeting/paneling/ceiling tiles

Number of projects (1,000)	12,051	7,224	4,827
Median expenditures (\$)	1,674	2,300	800
Total expenditures (1,000)	32,026,087	24,970,431	7,055,656

HVAC

Number of projects (1,000)	10,301	8,915	1,387
Median expenditures (\$)	3,150	3,429	1,800
Total expenditures (1,000)	40,379,006	36,507,489	3,871,517

Septic tank			
Number of projects (1,000)	387	319	68
Median expenditures (\$)	3,000	3,000	900
Total expenditures (1,000)	1,584,211	1,255,016	S
Water heater/dishwasher/garbage disposal			
Number of projects (1,000)	15,838	9,316	6,522
Median expenditures (\$)	500	700	400
Total expenditures (1,000)	11,087,649	7,899,118	3,188,531
Other interior			
Number of projects (1,000)	1,661	1,192	469
Median expenditures (\$)	1,200	1,500	754
Total expenditures (1,000)	4,660,744	3,947,101	713,642
Lot or Yard Additions and Replacements			
Driveways/walkways			
Number of projects (1,000)	4,099	2,712	1,387
Median expenditures (\$)	1,500	2,000	500
Total expenditures (1,000)	10,744,436	9,123,787	1,620,649
Fencing/walls			
Number of projects (1,000)	4,369	2,289	2,080
Median expenditures (\$)	1,000	2,000	600
Total expenditures (1,000)	9,239,951	6,722,489	2,517,462
Swimming pool/tennis court/recreational structures			
Number of projects (1,000)	806	445	361
Median expenditures (\$)	4,000	7,000	800
Total expenditures (1,000)	8,864,172	7,345,981	1,518,191
Shed/detached garage/other building			
Number of projects (1,000)	2,359	1,023	1,337
Median expenditures (\$)	1,500	2,500	1,000

Total expenditures (1,000)	9,333,571	5,637,621	3,695,950
Landscaping/sprinkler system			
Number of projects (1,000)	6,096	2,467	3,630
Median expenditures (\$)	800	2,000	500
Total expenditures (1,000)	12,123,260	8,640,867	3,482,393
Other			
Number of projects (1,000)	829	514	315
Median expenditures (\$)	1,500	2,250	S
Total expenditures (1,000)	3,429,179	2,945,964	483,215

Characteristics	Professional/Do-It-Yourself		
	Total Estimate	Professional Estimate	Do-It-Yourself Estimate
HOME IMPROVEMENT ACTIVITY IN LAST TWO YEARS (2013)			
Total			
Number of projects (1,000)	93,558	59,411	34,147
Median expenditures (\$)	1,000	2,000	500
Total expenditures (1,000)	300,831,306	246,338,538	54,492,768
Remodeling.			
Kitchen			
Number of projects (1,000)	2,954	1,700	1,253
Median expenditures (\$)	5,000	6,200	3,000
Total expenditures (1,000)	26,626,680	18,827,473	7,799,207
Bath			
Number of projects (1,000)	4,064	2,168	1,896
Median expenditures (\$)	2,500	4,000	1,500
Total expenditures (1,000)	18,685,777	13,962,662	4,723,115
Room Additions and Renovations.			
Kitchen			
Number of projects (1,000)	45	34	11
Median expenditures (\$)	35,000	35,821	15,000
Total expenditures (1,000)	1,584,009	1,441,692	142,317
Bath			
Number of projects (1,000)	546	293	253
Median expenditures (\$)	5,000	8,221	3,000
Total expenditures (1,000)	4,600,965	3,556,359	1,044,605

Bedroom			
Number of projects (1,000)	907	451	456
Median expenditures (\$)	3,343	8,500	1,600
Total expenditures (1,000)	12,578,231	10,045,582	2,532,649
Recreation Room			
Number of projects (1,000)	320	136	184
Median expenditures (\$)	5,000	6,627	3,700
Total expenditures (1,000)	2,899,929	1,581,672	1,318,257
Other			
Number of projects (1,000)	1,624	798	826
Median expenditures (\$)	3,500	6,866	1,848
Total expenditures (1,000)	14,945,765	11,958,530	2,987,235
Systems and Equipment			
Plumbing/pipes			
Number of projects (1,000)	2,767	1,716	1,051
Median expenditures (\$)	500	800	200
Total expenditures (1,000)	3,604,401	3,009,925	594,475
Electrical system			
Number of projects (1,000)	3,716	2,409	1,307
Median expenditures (\$)	500	800	200
Total expenditures (1,000)	4,269,937	3,549,517	720,420
Plumbing fixtures			
Number of projects (1,000)	6,881	3,437	3,444
Median expenditures (\$)	331	500	200
Total expenditures (1,000)	5,957,561	4,210,317	1,747,244
HVAC			
Number of projects (1,000)	7,250	6,340	910
Median expenditures (\$)	3,000	3,200	1,500
Total expenditures (1,000)	26,516,143	24,496,257	2,019,885

Appliances/major equipment			
Number of projects (1,000)	14,838	9,177	5,661
Median expenditures (\$)	400	500	334
Total expenditures (1,000)	8,617,672	6,333,578	2,284,094

Exterior Additions and Replacements.

Roofing

Number of projects (1,000)	5,851	4,876	975
Median expenditures (\$)	5,000	5,500	1,800
Total expenditures (1,000)	36,079,462	33,223,391	2,856,071

Siding

Number of projects (1,000)	1,677	1,219	458
Median expenditures (\$)	3,000	4,200	500
Total expenditures (1,000)	7,437,346	6,749,185	688,161

Windows/doors

Number of projects (1,000)	6,491	4,108	2,383
Median expenditures (\$)	1,100	1,800	500
Total expenditures (1,000)	16,670,157	13,622,788	3,047,369

Interior Additions and Replacements.

Insulation

Number of projects (1,000)	2,681	1,617	1,065
Median expenditures (\$)	573	955	300
Total expenditures (1,000)	3,060,617	2,498,934	561,683

Flooring/paneling/ceiling

Number of projects (1,000)	14,241	8,534	5,706
Median expenditures (\$)	1,000	1,647	500
Total expenditures (1,000)	27,522,730	21,585,632	5,937,098

Other interior

Number of projects (1,000)	1,761	1,236	524
----------------------------	-------	-------	-----

Median expenditures (\$)	1,200	1,500	800
Total expenditures (1,000)	5,620,345	4,070,664	1,549,681
Other Additions and Replacements.			
Deck/porch			
Number of projects (1,000)	489	282	207
Median expenditures (\$)	3,000	5,373	1,200
Total expenditures (1,000)	2,625,615	2,236,047	389,568
Patio/terrace/detached deck			
Number of projects (1,000)	2,737	1,534	1,203
Median expenditures (\$)	2,000	3,500	1,000
Total expenditures (1,000)	11,324,775	9,034,084	2,290,691
Garage			
Number of projects (1,000)	94	73	21
Median expenditures (\$)	18,000	24,000	500
Total expenditures (1,000)	2,206,566	2,140,830	65,736
Carport			
Number of projects (1,000)	94	58	37
Median expenditures (\$)	1,400	2,269	500
Total expenditures (1,000)	440,123	381,558	58,565
Shed			
Number of projects (1,000)	1,547	746	801
Median expenditures (\$)	1,400	2,500	800
Total expenditures (1,000)	8,344,883	6,885,567	1,459,315
Swimming pool/tennis court/recreational structures			
Number of projects (1,000)	628	359	269
Median expenditures (\$)	3,000	5,075	600
Total expenditures (1,000)	4,951,069	4,436,168	514,901
Other exterior			
Number of projects (1,000)	7,548	4,620	2,928

Median expenditures (\$)	1,500	2,000	500
Total expenditures (1,000)	19,708,734	16,325,326	3,383,408
Disaster Repairs			
Number of projects (1,000)	1,807	1,490	316
Median expenditures (\$)	7,000	7,600	2,000
Total expenditures (1,000)	23,951,815	20,174,799	3,777,017
Other interior			
Number of projects (1,000)	1,661	1,192	469
Median expenditures (\$)	1,200	1,500	754
Total expenditures (1,000)	4,660,744	3,947,101	713,642
Lot or Yard Additions and Replacements			
Driveways/walkways			
Number of projects (1,000)	4,099	2,712	1,387
Median expenditures (\$)	1,500	2,000	500
Total expenditures (1,000)	10,744,436	9,123,787	1,620,649
Fencing/walls			
Number of projects (1,000)	4,369	2,289	2,080
Median expenditures (\$)	1,000	2,000	600
Total expenditures (1,000)	9,239,951	6,722,489	2,517,462
Swimming pool/tennis court/recreational structures			
Number of projects (1,000)	806	445	361
Median expenditures (\$)	4,000	7,000	800
Total expenditures (1,000)	8,864,172	7,345,981	1,518,191
Shed/detached garage/other building			
Number of projects (1,000)	2,359	1,023	1,337
Median expenditures (\$)	1,500	2,500	1,000
Total expenditures (1,000)	9,333,571	5,637,621	3,695,950

Landscaping/sprinkler system			
Number of projects (1,000)	6,096	2,467	3,630
Median expenditures (\$)	800	2,000	500
Total expenditures (1,000)	12,123,260	8,640,867	3,482,393
Other			
Number of projects (1,000)	829	514	315
Median expenditures (\$)	1,500	2,250	S
Total expenditures (1,000)	3,429,179	2,945,964	483,215

Characteristics	Professional/Do-It-Yourself		
	Total	Professional	Do-It-Yourself
HOME IMPROVEMENT ACTIVITY IN LAST TWO YEARS (2011)			
Total			
Number of projects (1,000)	116,263	73,015	43,248
Median expenditures (\$)	1,000	1,999	500
Total expenditures (1,000)	348,536,558	287,026,972	61,509,586
Remodeling.			
Kitchen			
Number of projects (1,000)	3,608	2,081	1,527
Median expenditures (\$)	5,000	7,993	3,000
Total expenditures (1,000)	34,661,061	26,886,023	7,775,039
Bath			
Number of projects (1,000)	4,825	2,503	2,323
Median expenditures (\$)	2,500	4,000	1,500
Total expenditures (1,000)	22,723,885	16,388,045	6,335,840
Room Additions and Renovations.			
Kitchen			
Number of projects (1,000)	63	52	11
Median expenditures (\$)	27,353	30,000	8,000
Total expenditures (1,000)	1,830,275	1,683,443	146,832
Bath			
Number of projects (1,000)	713	392	321
Median expenditures (\$)	3,500	5,882	2,000
Total expenditures (1,000)	4,523,881	3,460,385	1,063,497
Bedroom			

Number of projects (1,000)	1,142	506	636
Median expenditures (\$)	2,500	5,000	1,500
Total expenditures (1,000)	8,537,461	5,954,937	2,582,524
Recreation Room			
Number of projects (1,000)	490	202	288
Median expenditures (\$)	3,000	6,882	1,600
Total expenditures (1,000)	3,486,584	2,662,713	823,871
Other			
Number of projects (1,000)	1,978	997	981
Median expenditures (\$)	3,000	5,000	1,500
Total expenditures (1,000)	16,627,399	13,298,699	3,328,700
Systems and Equipment			
Plumbing/pipes			
Number of projects (1,000)	3,312	2,082	1,231
Median expenditures (\$)	500	900	180
Total expenditures (1,000)	4,506,681	3,955,534	551,146
Electrical system			
Number of projects (1,000)	4,434	2,864	1,569
Median expenditures (\$)	500	800	200
Total expenditures (1,000)	4,976,258	4,231,366	744,892
Plumbing fixtures			
Number of projects (1,000)	7,944	3,811	4,133
Median expenditures (\$)	305	500	200
Total expenditures (1,000)	6,207,328	4,125,458	2,081,870
HVAC			
Number of projects (1,000)	9,574	8,365	1,209
Median expenditures (\$)	3,000	3,176	1,500
Total expenditures (1,000)	33,214,557	30,498,058	2,716,499
Appliances/major equipment			

Number of projects (1,000)	17,913	11,276	6,637
Median expenditures (\$)	400	500	320
Total expenditures (1,000)	10,213,056	7,588,909	2,624,147

Exterior Additions and Replacements.

Roofing

Number of projects (1,000)	7,269	5,950	1,319
Median expenditures (\$)	4,800	5,276	1,807
Total expenditures (1,000)	42,534,922	38,896,570	3,638,351

Siding

Number of projects (1,000)	2,154	1,444	710
Median expenditures (\$)	3,000	4,500	762
Total expenditures (1,000)	10,342,508	8,965,278	1,377,230

Windows/doors

Number of projects (1,000)	8,676	5,629	3,047
Median expenditures (\$)	1,282	2,000	500
Total expenditures (1,000)	23,145,692	19,648,147	3,497,546

Interior Additions and Replacements.

Insulation

Number of projects (1,000)	4,085	2,116	1,970
Median expenditures (\$)	500	1,000	300
Total expenditures (1,000)	4,287,875	3,214,117	1,073,757

Flooring/paneling/ceiling

Number of projects (1,000)	18,320	10,907	7,413
Median expenditures (\$)	1,000	1,510	500
Total expenditures (1,000)	31,910,709	25,087,900	6,822,809

Other interior

Number of projects (1,000)	1,780	1,218	561
Median expenditures (\$)	1,000	1,500	500

Total expenditures (1,000)	4,129,829	3,416,024	713,805
Other Additions and Replacements.			
Deck/porch			
Number of projects (1,000)	505	287	217
Median expenditures (\$)	2,000	3,000	1,342
Total expenditures (1,000)	2,701,309	2,290,101	411,208
Patio/terrace/detached deck			
Number of projects (1,000)	3,500	1,835	1,665
Median expenditures (\$)	2,000	3,176	1,000
Total expenditures (1,000)	13,022,905	9,963,322	3,059,583
Garage			
Number of projects (1,000)	158	87	71
Median expenditures (\$)	15,000	20,250	5,000
Total expenditures (1,000)	2,621,310	2,165,996	455,314
Carport			
Number of projects (1,000)	158	82	76
Median expenditures (\$)	1,500	1,600	1,300
Total expenditures (1,000)	399,581	240,654	158,927
Shed			
Number of projects (1,000)	2,098	977	1,121
Median expenditures (\$)	1,429	2,600	800
Total expenditures (1,000)	8,599,423	5,927,181	2,672,242
Swimming pool/tennis court/recreational structures			
Number of projects (1,000)	713	414	300
Median expenditures (\$)	2,500	6,000	500
Total expenditures (1,000)	7,417,915	7,102,007	315,908
Other exterior			
Number of projects (1,000)	9,003	5,419	3,584
Median expenditures (\$)	1,247	2,000	500

Total expenditures (1,000)	22,898,421	18,263,708	4,634,713
Disaster Repairs			
Number of projects (1,000)	1,846	1,519	327
Median expenditures (\$)	7,000	8,000	2,736
Total expenditures (1,000)	23,015,733	21,112,396	1,903,337
Other interior			
Number of projects (1,000)	1,661	1,192	469
Median expenditures (\$)	1,200	1,500	754
Total expenditures (1,000)	4,660,744	3,947,101	713,642
Lot or Yard Additions & Replacements.			
Driveways/walkways			
Number of projects (1,000)	4,099	2,712	1,387
Median expenditures (\$)	1,500	2,000	500
Total expenditures (1,000)	10,744,436	9,123,787	1,620,649
Fencing/walls			
Number of projects (1,000)	4,369	2,289	2,080
Median expenditures (\$)	1,000	2,000	600
Total expenditures (1,000)	9,239,951	6,722,489	2,517,462
Swimming pool/tennis court/recreational structures			
Number of projects (1,000)	806	445	361
Median expenditures (\$)	4,000	7,000	800
Total expenditures (1,000)	8,864,172	7,345,981	1,518,191
Shed/detached garage/other building			
Number of projects (1,000)	2,359	1,023	1,337
Median expenditures (\$)	1,500	2,500	1,000
Total expenditures (1,000)	9,333,571	5,637,621	3,695,950
Landscaping/sprinkler system			
Number of projects (1,000)	6,096	2,467	3,630

Median expenditures (\$)	800	2,000	500
Total expenditures (1,000)	12,123,260	8,640,867	3,482,393
Other			
Number of projects (1,000)	829	514	315
Median expenditures (\$)	1,500	2,250	S
Total expenditures (1,000)	3,429,179	2,945,964	483,215

FATAL DATA VISUALIZATION HOME

SELECTED YEARS

RESET FILTER

FILTER DATA

Year Range: 2001 - 2020 Unintentional Fall Deaths x Sex: Both Sexes Age Range: All Ages Race: All F

547,043	6,183,393,140	8.85	8.04	1,362,237
Number of Deaths	Population	Crude Rate	Age-Adjusted Rate	Years of Potential Life L

CAUSES OF INJURY-RELATED DEATH

For more information on a single cause of injury, select an element from the diagram to the right to filter the rest of the dashboard.

Hover over elements for details

Data source: NCHS Vital Statistics System for numbers of deaths. Bureau of Census for population estimates.

Users can filter data by clicking on chart or by selecting Filters from Filter Data button when using keyboard navigation.

DOWNLOAD DATA / IMAGE

Group By:

View As:

SUBMIT

** indicates Unstable values, -- indicates Suppressed values, --* indicates Secondary Suppression

GO TO TOP

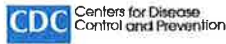

Leading Causes of Nonfatal Injury

Export Options

WISQARS - Data Filters

Data Years: 2001 to 2020 | Number of Causes: Top 10 | Intent of Injury: All Injuries | Sex: Both Sexes | Disposition: All Cases
 Age: 1-14 in 5-year groups; 15 65+ in 10-year groups

Choose Filters

10 Leading Causes of Nonfatal Emergency Department Visits, United States 2001 to 2020, All Injuries, Disposition: All Cases, Both Sexes, All Races, All Ages

Unintentional Assault Self-Harm

	< 1	1 to 4	5 to 9	10 to 14	15 to 24	25 to 34	35 to 44	45 to 54	55 to 64	65+	All Ages
1	Unintentional Fall 2,502,385	Unintentional Fall 16,372,166	Unintentional Fall 12,098,025	Unintentional Fall 11,207,526	Unintentional Struck by /Against 18,061,779	Unintentional Fall 14,564,377	Unintentional Fall 14,555,015	Unintentional Fall 16,694,734	Unintentional Fall 16,342,377	Unintentional Fall 47,487,924	Unintentional Fall 167,959,317
2	Unintentional Struck by /Against 591,729	Unintentional Struck by /Against 6,700,358	Unintentional Struck by /Against 7,569,449	Unintentional Struck by /Against 10,631,148	Unintentional Fall 16,124,530	Unintentional Overexertion 12,223,390	Unintentional Overexertion 10,790,668	Unintentional Overexertion 8,343,859	Unintentional Struck by /Against 4,788,473	Unintentional Struck by /Against 5,138,015	Unintentional Struck by /Against 83,016,455
3	Unintentional Bite: Other, including sting 234,289	Unintentional Bite: Other, including sting 2,769,068	Unintentional Cut/Pierce 2,139,090	Unintentional Overexertion 5,258,733	Unintentional Motor Vehicle Occupant 14,304,138	Unintentional Struck by /Against 12,207,063	Unintentional Struck by /Against 9,644,374	Unintentional Struck by /Against 7,680,435	Unintentional Overexertion 4,606,116	Unintentional Overexertion 3,964,282	Unintentional Overexertion 61,396,600
4	Unintentional Foreign Body 192,533	Unintentional Foreign Body 2,413,262	Unintentional Bite: Other, including sting 1,884,417	Unintentional Cut/Pierce 2,522,629	Unintentional Overexertion 13,148,869	Unintentional Motor Vehicle Occupant 11,191,851	Unintentional Motor Vehicle Occupant 8,357,307	Unintentional Motor Vehicle Occupant 6,758,207	Unintentional Motor Vehicle Occupant 4,313,897	Unintentional Motor Vehicle Occupant 3,841,979	Unintentional Motor Vehicle Occupant 52,337,178
5	Unintentional Fire / Burn 185,185	Unintentional Cut/Pierce 1,573,107	Unintentional Pedal cyclist (bicycle, etc.) 1,552,384	Unintentional Pedal cyclist (bicycle, etc.) 1,955,699	Unintentional Cut/Pierce 8,631,457	Unintentional Cut/Pierce 8,167,950	Unintentional Cut/Pierce 6,468,728	Unintentional Other Specified 5,389,638	Unintentional Cut/Pierce 3,431,278	Unintentional Cut/Pierce 2,779,745	Unintentional Cut/Pierce 41,160,894
6	Unintentional Other Specified 156,799	Unintentional Overexertion 1,466,098	Unintentional Overexertion 1,488,024	Unintentional Unknown / Unspecified 1,750,279	Assault - Other Struck by /Against 7,970,286	Assault - Other Struck by /Against 6,240,240	Unintentional Other Specified 5,229,003	Unintentional Cut/Pierce 5,326,151	Unintentional Other Specified 3,222,871	Unintentional Poisoning 1,815,178	Unintentional Other Specified 27,749,865
7	Unintentional Inhalation / Suffocation 139,460	Unintentional Other Specified 1,039,544	Unintentional Motor Vehicle Occupant 1,206,958	Unintentional Motor Vehicle Occupant 1,580,880	Unintentional Other Specified 4,808,939	Unintentional Other Specified 5,584,544	Assault - Other Struck by /Against 4,229,339	Unintentional Poisoning 4,138,681	Unintentional Poisoning 2,670,665	Unintentional Bite: Other, including sting 1,735,775	Assault - Other Struck by /Against 25,201,448
8	Unintentional Cut/Pierce 118,548	Unintentional Fire / Burn 999,974	Unintentional Foreign Body 1,120,799	Assault - Other Struck by /Against 1,507,773	Unintentional Bite: Other, including sting 3,246,432	Unintentional Poisoning 3,919,879	Unintentional Poisoning 3,891,642	Assault - Other Struck by /Against 2,878,372	Unintentional Bite: Other, including sting 1,724,033	Unintentional Other Specified 1,475,256	Unintentional Bite: Other, including sting 21,105,233
9	Unintentional Overexertion 104,837	Unintentional Poisoning 862,709	Unintentional Bite: Dog 850,041	Unintentional Bite: Other, including sting 1,176,531	Unintentional Poisoning 3,052,105	Unintentional Bite: Other, including sting 3,165,595	Unintentional Bite: Other, including sting 2,680,900	Unintentional Bite: Other, including sting 2,487,757	Assault - Other Struck by /Against 1,195,386	Unintentional Other Transportation 1,366,320	Unintentional Poisoning 20,858,231
10	Unintentional Unknown / Unspecified 101,913	Unintentional Unknown / Unspecified 841,770	Unintentional Other Transportation 763,369	Unintentional Other Transportation 1,007,414	Unintentional Unknown / Unspecified 2,938,464	Unintentional Unknown / Unspecified 2,114,561	Unintentional Unknown / Unspecified 1,750,668	Unintentional Unknown / Unspecified 1,506,079	Unintentional Unknown / Unspecified 981,476	Unintentional Unknown / Unspecified 1,300,755	Unintentional Unknown / Unspecified 14,008,972

Display as: Chart | Statistic to display: Estimated Number | Highlight Injury Cause: Unintentional Fall

Apply Selections

10 Leading Causes of Nonfatal Injury for ages <1 All Injuries, 2001 to 2020, Both Sexes, All Cases, All Races

**Relevant Incidents involving Ceiling (Paddle)
Fans 2022-2013
Public Input 2484**

This report contains the narrative reports of incidents involving injuries from ceiling (paddle) fans. These reports come from the National Electronic Injury Surveillance System (NEISS), which is maintained by the Consumer Product Safety Commission. According to the NEISS Coding Manual, “The primary purpose of NEISS is to provide timely data on unintentional consumer product-related injuries and deaths occurring in the U.S. NEISS injury data are gathered from the emergency departments (ED) of 96 hospitals selected as a probability sample of all U.S. hospitals with 24-hour EDs and at least 6 inpatient beds. Each participating NEISS hospital is hand-selected by CPSC

because it provides an important representation of all other hospitals of its size and unique characteristics in the U.S.” (January 2022, P.1) It is important to note that at the end of 2021, there were 6,129 hospitals in the US (<https://www.statista.com/statistics/185843/number-of-all-hospitals-in-the-us/#:~:text=This%20statistic%20shows%20the%20number,2021%2C%20there%20were%206%2C129%20hospitals>). In addition, there are approximately “10,800 active urgent care clinics in the US” (<https://www.definitivehc.com/resources/healthcare-insights/urgent-care-clinics-us/#:~:text=According%20to%20data%20from%20Definitive,urgent%20care%20clinics%20per%20capita.>). This strongly indicates that the number of injuries is much higher.

The primary purpose is collect the necessary information to begin treatment. It is important to understand that some incidents may simply be classified as falls, without digging deeper to determine what the patient was doing at the time, because the additional detail may not be considered clinically important. Such incidents will not appear correctly in these statistics. A few of the incidents that are included in this report involve pieces of fans falling on occupants. Such incidents likely occurred because the installation was not as robust as it needed to be, allowing parts to loosen and fall.

This report does not include workplace injuries. Workplace injury data is collected by the National Institute of Occupational Safety and Health.

There are a number of incidents involving injuries to occupants of bunk beds. There are also incidents involving injuries to children who threw some object at a fan. Such incidents are excluded from this report, because they are not germane to this public input.

Relevant Incidents involving Ceiling (Paddle) Fans 2022-2013

2022	2022
CPSC Case #	Narrative
220419511	25year old male PRESENTS WITH EVALUATION AFTER HEAD INJURY. PATIENT STATES HE WAS STANDING NEAR A DOOR WHEN SUDDENLY PART OF THE CEILING FELL AND CEILING FAN STRUCK HIM IN THE TOP OF HIS HEAD CAUSING HIM TO FALL BACKWARDS. DX: STRAIN OF MUSCLE,FASCIA AND TENDON AT NECK LEVEL. SPRAIN OF INTERPHALANGEAL JOINT OF UNSPECIFIED FINGER.
220348929	41 year old male REPORTS A FAN FELL AND STRUCK HIM IN THE THUMB.DX: LACERATION OF LEFT HAND
220361987	27 year old male ELECTROCUTED AT HOME WHILE TRYING TO INSTALL A CEILING FAN, TRIED TO TURN ON WHILE THE OTHER HAND WAS TOUCHING DISHWASHER. DX ELECTROCUTION ACCIDENT, CHEST STRAIN
220547269	64year old male C/O FOREIGN BODY. PT WAS SLEEPING & CEILING FAN FELL DOWN ONTO HIM. THE BULB BROKE OVER HIS LEG. DX: MULTIPLE ABRASIONS, LLE LAC, KNEE CONTUSION
220567703	69year old female, TO ER AFTERFALL AT HOME, PT REACHING FOR FAN & FELL HITTING HEAD ON FLOOR, PT SUSTAINED LACERATION OF CHIN, & SKIN TEAR TO BILAT FOREARMS PT HAS BUMP ON BACK OF HEAD, NO LOC, PT IS ON ***, PT HAS SOME NAUSEA, FALL OCCURED 1 HR AGO, NO DIZZINES & WAS ABLE TO GET SELF UP HERSELF DX FALL, CHIN LACERATION, SKIN TEAR TO BILATERAL FOREARMS
220571365	69 year old female STATES THAT A CEILING FAN FELL ON HER IN FEBRUARY 2022, AND HAS SINCE BEEN EXPERIENCING DIZZINESS AND FEELINGS OF BEING OFF-BALANCE. DX CHRONIC CONFUSION, CHRONIC BALANCE PROBLEM, CHRONIC VISUAL DISTURBANCE
220600649	52year old female HAD A CEILING FAN FALL ONTOP OF RIGHT FOOT DX: CONTUSION TO FOOT

220616691 59year old female, UP ON A TABLE TRYING TO FIX CEILING FAN WHEN FELT DIZZY, STEPPING DOWN ON A CHAIR WHICH BROKE UNDERNEATH HER WEIGHT AND FELL, +ECCHYMOSIS TO THIGH
DX: FALL, INTIAL ENCOUNTER; NEARSYNCOPE; LEFT WRIST PAIN; LEFT LEG PAIN

220727044 46year old female PRESENTS AFTER A CEILING FAN FELL ON HER HEAD WHILE SHE WAS AT A LAUNDROMAT. SHE HAS LACERATION TO HER RIGHT FOREHEAD. DX: FOREHEAD LACERATION

220868992 55 year old female WAS HIT ON THE KNEE BY A FALLING FAN. DX: LEFT KNEE CONTUSION.

220900699 32year old female PT REACHED UP TO STABILIZE A BROKEN FAN WHEN SHE WAS ELECTRICAL SHOCK TO HAND. DX: ACUTE RIGHT HAND ELECTRICAL INJURY.

220961902 47year old male PT WAS AT HOME UP ON A LADDER HANGING CEILING FAN LOST BALANCE FALLING HITTING LEFT HEAD ON CEMENT. DX: FALL, HEAD INJURY.

220751022 47year old female HAD A CEILING FAN FALL ON HEAD. DX SHOULDER PAIN, NECK PAIN

220949006 34year old female PT HAD THE CEILING FAN FALL ONTO HER RT LOWER LEG AND FOOT HURT TOE PAINFUL DX FRACTURE RT GREAT TOE, CONTUSION RT LOWER LEG

220822776 38year old female, STANDING ON A LADDER HELPING BOYFRIEND PUTTING A FAN WHEN FELL DX: RIGHT WRIST SPRAIN

220839695 31year old male,A CEILING FAN FELL OFF THE CEILING AN HIT HIM ON BACK,DX:LAC BACK

220867719 47year old male, STANDING ON THE BED TRYING TO HOOK A CEILING FAN AND FELL OFF AGAINST A CHAIR DX: HEMATOMA OF BUTTOCK

220925332 58year old male WAS HIT IN THE HEAD BY A FALLING PIECE OF A CEILING FAN. DX: HEAD TRAUMA, CONCUSSION

220926009 9month old male STRUCK BY GLASS LIGHT FIXTURE GLOBE THAT FELL OFF CEILING FAN. DX: HEAD INJURY, FACIAL LAC

220960075 57 year old male WAS CHANGING OUT A FAN, DROPPED IT AND CUT HIS R HAND 5TH DIGIT, "TO THE BONE." DX: LEFT WITHOUT BEING SEEN

221007001 18 month old male - PART OF CEILING FAN FELL AND HIT PT ON THE HEAD. DX HEAD INJURY

221014739 25year old female HAD A CEILING FAN FALL HITTING HER IN THE HEAD. DX: CLOSED HEAD INJURY, NECK PAIN

221020990 25year old female HAD A CEILING FAN FALL HITTING HER NECK, DX: CONTUSION NECK

221021003 52year old male HAD A CEILING FAN FALL NEAR HIM AND A PIECE BROKE OFF AND HIT HIM IN THE RT EYE. DX: TRAUMATIC IRITIS

230200510 35year old female STS A CEILING FAN FELL ON HEAD AT LAUNDRY MAT C/O NECK PAIN DX ACUTE TORTICOLLIS

221007169 83year old female WITH INJURY TO HEAD, HER HUSBAND WAS STANDING ON THE BED WORKING ON A FAN, HE FELL AND HIT PATIENT'S HEAD WITH HIS HEAD. DX: CONTUSION WITH SOFT TISSUE HEMATOMA SCALP.

221007170 80year old male WITH FALL AT HOME, STANDING ON BED WORKING ON A CEILING FAN, FELL OFF BED AND HIT FLOOR DX: LAC. SCALP; SOFT TISSUE HEMATOMA SCALP

221029830 8year old female PIECE OF CEILING FAN BROKE & FELL ON PT. DX: ABR FACE

221168661 71year old female WAS SITTING IN HER WHEELCHAIR AT HOME WHEN CEILING COLLAPSED AND CEILING FAN LANDED ON PT. DX: CLOSED COMPRESSION FX L4 AND WEDGE COMPRESSION FX, L3, ACUTE NECK AND BACK PAIN.

221227240 2year old male PRESENTS AFTER A CEILING FAN FELL BESIDE HIM, CAUSING MULTIPLE LACERATIONS TO HIS RIGHT FOREARM. DX: LACERATION OF MULTIPLE SITES OF RIGHT UPPER EXTREMITY

221210342 74 year old male CEILING FAN FELL ON HEAD DX; SCALP LAC

2021
CPSC Case #

2021
Narrative

210123158 23year old female HAD A CEILING FAN FALL ONTO HER HEAD AT HOME DX: CLOSED HEAD INJURY;
LACERATION SCALP

210127852 48 year old male INJURED HAND,FELL OFF LADDER,CHANGING CEILING FAN,AT HOME. DX-
CONTUSION LEFT HAND

210147668 41year old male ELECTRICAL INJURY TO HAND WHILE CHANGING A CEILING FAN AT HOME. DX:
LOW VOLTAGE ELECTRIC SHOCK HAND, LEFT HAND PARASTHESIA.

210148674 13 year old female AT HOME WHEN A CEILING FAN FELL ONTOP OF HER C/O SHOULDER PAIN DX
SHOULDER INJURY

210202412 53 year old female INJURED HEAD,NECK,CEILING FAN FELL ON HEAD WHILE PATIENT WAS LAYING
IN BED,AT HOME. DX-TRAUMATIC HEAD INJURY,INJURY NECK

210211645 68year old male WAS WORKING ON A CEILING FAN AND FELL OFF THE LADDER DX: SPLEEN
FRACTURE

210222909 8month old male JHAD A SECTION OF THE CEILING FAN FALL ONTO FACE WHILE SLEEPING IN
month old males BED DX: LACERATION TO FACE

210232864 39year old male WAS HANGING A CEILING FAN AT HOME AND IT FELL ONTO HEAD DX: CLOSED
HEAD INJURY LACERATION TO SCALP

210233092 44year old female WAS AT HOME WHEN A FAN CAUGHT ON FIRE SHE INHALED THE SMOKE AND
DEVELOPED COUGHING NO COHGB DRAN NS IF FD ON SCENE DX: SMOKE INHALATION

210303893 73 year old male FIXING CEILING FAN AND FELL FROM LADDER HIT HEAD ON NIGHTSTAND DX CHI

210307324 88year old male WAS TRYING TO HANG A CEILING FAN ON THE CEILING AND DEVELOPED PAIN IN
RIGHT SHOULDER DX: RIGHT SHOULDER STRAIN

210342628 9year old male CEILING FAN FELL ONTO PT; DX: CHI, SCALP LAC

210343317 59 year old female HIT HEAD ON CEILING FAN AT HOME IN KITCHEN DX SCALP LACERATION

210350387 48year old male PT HANGING UP A CEILING FAN, FELT POPPING/SNAPPING SENSATION IN RT SHOULDER DX: ACUTE SHOULDER PAIN #

210357241 34year old female WAS ON A LADDER HANGING A CEILING FAN ON THE CEILING AND IT FELL AND LACERATED HER LEFT EYEBROW DX: FACIAL LACERATION

210416920 30year old male WAS SITTING O HIS COUCH WHEN A CEILING FAN FELL ONTO HIS HEAD DX: CLOSED HEAD INJURY

210417621 45 year old male STANDING ON LADDER TO INSTALL CEILING FAN, HURT BACK. DX LS STRAIN

210448460 47year old female HAD A CEILING FAN FROM HER KITCHEN FALL ON HER HEAD DX: CLOSED HEAD INJURY

210507955 57year old female CEILING FAN FELL ONTO RIGHT HAND DX: LACERATION TO HAND

210511950 53year old male WHILE PUTTING FAN UP,FELL OFF LADDER--DX:FX SHOULDER+RIB

210534932 21 year old male WAS STANDING ON A BED PUTTING UP A CELING FAN WHEN HE FELL OFF OF THE BED LANDING ON OUTSTRETCHED RIGHT ARM. DX: RIGHT SHOULDER PAIN S/P FALL, SUSPECTED ROTATOR CUFF INJURY

210538106 37year old male HAD A CEILING FAN FALL ONTO HEAD. DX: CHI

210616701 29 year old male. PT C/O OF FOREHEAD PAIN AFTER CEILING FAN FELL FROM CEILING AT HOME. DX: SCALP CONTUSION

210616702 10 year old male. PT C/O HEAD PAIN AFTER CEILING FAN FELL FROM CEILING AT HOME. DX: SCALP CONTUSION

210631134 40year old male WAS HANGING A CEILING FAN AND IT FELL ONTO FACE DX: NASAL FRACTURE

210638703 44 year old male WAS INSTALLING A CEILING FAN AND HAD IT RESTING ON TOP OF A LADDER; IT FELL OFF THE LADDER STRIKING HIM ON THE HEAD +HEADACHE DX CHI, SCALP HEMATOMA, SUPERFICIAL LAC

210715623 62 year old male. HEAD INJURY AFTER A CEILIGN FAN FELL & HIT HIM ON THE TOP OF THE HEAD.
DX: CLOSED HEAD INJURY; SCALP LAC

210721503 64year old female, A CEILING FAN, FELL OFF THE CEILING STRIKING HEAD WITHOUT LOSS OF
CONSCIOUS, DX: LACERATION OF SCALP; MINOR HEAD INJURY

210741839 32year old female WAS WALKING TO HER ROOM WHEN THE CEILING AND CEILING FAN COLLAPSED
ONTO HER HEAD DX: NECK PAIN

210844629 45year old female WAS IN AN APARTMENT FIRE WHEN AN ELECTRICAL FAN CAUGHT FIRE INHALED
THE SOKE AND STARETD TO COUCH AND WHEEZE COHGB OF 3 FD WAS ON SCENE DX: SMOKE
INHALATION

210847909 31 year old female CEILING FAN FELL ON HEAD DX: SCALP CONTUSION

210865407 44year old female HAD A CEILING FAN FALL ONTO HEAD DX: CONCUSSION

210926430 10year old female HAD A CEILING FAN FALL ONTO HER NOSE. DX: NOSE SWELLING; LWBS

211052894 88 year old male HAD A CEILING FAN FALL AND HIT HIM ON THE HEAD. DX: CLOSED HEAD INJURY.

211066278 52year old male PATIENT PUTTING UP A CEILING FAN ON 6 FOOT LADDER AND LOST BALANCE
FALLING HAVING LEFT RIB PAIN, LEFT ELBOW EFFUSION DX: RIB FRACTURE, ELBOW INJURY,
ACCIDENTAL FALL FROM LADDER

211200580 21year old male PT WAS AT HOME WHEN A CEILING FAN FELL HITTING SHOULDER. DX: SHOULDER
PAIN.

2020	2020
CPSC Case #	Narrative
200105581	48year old male WITH BACK PAIN AFTER FALLING OFF OF LADDER WHILE TRYING TO INSTALL A CEILING FAN, WAS APPROX 4 STEPS UP WHEN HE LOST HIS BALANCE AND FELL BACKWARDS STRIKING A WINDOWSILL ON LOWER BBACK, DX: ACUTE ON CHRONIC LS BACK PAIN

200138673 29year old male WAS TRYING TO HANG A CEILING FAN AT HOME WHEN IT FELL ON HIM. DX: CERVICAL STRAIN, THORACIC STRAIN.

200153632 50 year old female HX OF MS CEILING FAN FELL ON HEAD, PRESENTS WITH CONFUSION, HEAD PAIN. DX: HEAD PAIN

200315385 64 year old male C/O SHOULDER PAIN S/P REACHING UP TO INSTALL A CEILING FAN AT HOME. DX: SHOULDER PAIN

200529122 25year old male CUT TO [R] RING FINGER FROM CEILING FAN; HE WAS CHANGING IT FELL; DX: [R] RING FINGER LACERATION

200427815 1month old female CELING FELL IN BECAUSE OF WATER LEAKAGE AND THE CEILING FAN FELL ONTO PT. DX EYE? INJURY

200502133 80year old male WAS ON A LADDER WORKING ON A FAN AND FELL OFF DX: LEFT HIP FX

200719409 68year old male.FALLING DOWN FROM LADDER INSTALLING CEILING FAN.DX.HEAD TRAUMA AND,CONT.LT.ANKLE

200648912 8year old male WAS HIT ON THE RIGHT SHOULDER WHEN A CEILING FAN FELL. DX: SHOULDER LACERATION.

200737210 29year old female TWISTED NECK TRYING TO CATCH FALLING FAN, DX: NECK PAIN

200804044 79 year old male FELL YESTERDAY WHILE TRYING TO MOUNT A KITCHEN FAN, FELL OFF CHAIR HE WAS STANDING ON HITTING HIS HEAD AND FACE, DX: ACUTE HEAD INJURY, FACIAL ABRASION, FRACTURE TRANSVERSE LUMBAR VERTEBRA

200805056 45year old male WAS AT HOME AND HIS CEILING FAN FELL ON HIM. DX NECK AND BACK PAIN

200828084 7year old female HAD CELING FAN ACCDIENTALLY FALL ON HER HEAD AND FACE. DX FACIAL LACERATION@

200906426 19year old male PRESENTS AFTER A CELIING FAN FELL AND HE INHALED SOME DUST PARTICLES AND EXPERIENCED CHEST TIGHTNESS AND WHEEZING, DX: MILD INTERMITTENT ASTHMA

200915596 48 year old female WAS HIT ON THE HAND BY A FALLING CEILING FAN. DX: RIGHT HAND FRACTURE.

210202899 30year old male WAS INSTALLING A CEILING FAN AND ACCIDENTALLY BEGAN TO COME DOWN LOST HIS BALANCE FALLING ON A BOX FRAME RESULTING IN LACERATION TO HIS HAND AND LACERATION TO RIGHT FOOT. DX: LACERATION RIGHT FOOT AND LACERATION RIGHT HAND

201020077 48year old male WAS PUTTING UP A CEILING FAN AT HOME WHEN HE WAS STRUCK IN THE WRIST WITH THE BLADE DX: CONTUSION TO WRIST

201108499 29year old male PATIENT HAVING RIGHT UPPER BACK PAIN SINCE A CEILING FAN FELL ON HIS RIGHT ARM TODAY DX: RIGHT UPPER BACK PAIN

201200650 37year old female PT STS CEILING FAN FELL FROM THE CEILING HITTING PT IN THE LEG. DX: LEG CONTUSION.

201200651 31year old male PT STS CEILING FANS FELL ON HIM WHILE IN BED HITT LEGS AND HIP. DX: LEG CONTUSION.

201234762 69year old female.WHILE SLEEPING CEILING FAN FELL ON FOREHEAD.DX.LAC.FOREHEAD

201110731 45year old male HAD A CEILING FAN FALL ONTO HIS HEAD FOUR WEEKS AGO CONTINUED HEADACHE DX: POST CONCUSSION SYNDROME

201231242 8year old male WAS AT HIS GRANDMA'S WHEN THE GLOBE FROM THE CELING FAN FELL AND PATIENT TRIED TO CATCH IT, CUTTING HIS RIGHT ARM. DX: LACERATION OF RIGHT FOREARM.

201251388 63year old female PRESENTS AFTER A FALL X2 WEEKS. PT STATES SHE WAS PUTTING UP A CEILING FAN WHEN SHE LOST HER BALANCE, FELL ONTO THE BED AND THEN ONTO HER BUTTOCKS ON THE CEMENT FLOOR. -HEAD STRIKE. DX: FALL, COCCYX CONTUSION

2019
CPSC Case #

2019
Narrative

190115444 4year old male WHO WAS AT HOME WHEN A CEILING FAN FELL FROM 8-1/2 TO 9 FEET HIGH. HE WAS BENDING OVER AT THE TIME, AND IT HIT HIM IN THE BACK. DX: LACERATION OF BACK.

190119288 5year old female EYE PAIN AND ABR NOSE, CEILING FAN FELL OFF CEILING & STRUCK FACE

190431484 25year old male C/O HEAD INJURY. PT WAS SITTING ON COUCH WHEN A CEILING FAN FELL & HIT HIM ON THE HEAD, -LOC.DX MINOR HEAD INJURY WITHOUT LOSS OF CONSCIOUSNESS.

190438414 31year old male WAS INSTALLING CEILING FAN WHEN IT FELL ON HEAD. -FALL -LOC +HEAD PAIN DX SCALP LAC

190442421 65year old female WAS SHOCKED BY A MALFUNCTIONING CEILING FAN SHOCK WENT THROUGH HER ARM AND THROUGH HER BACK ABOUT 6 FEET DX: ELECTRIC SHOCK INJURY

190504645 70year old male ON LADDER FIXING CEILING FAN WHEN HE FELL, 6-7 FT, LANDED ON SHOULDER COMPLAINS OF PAIN DX-CONTUSION RT SHOULDER, CONTUSION SCALP

190510351 3YR M PLAYING IN LIVING ROOM WHEN CEILING FAN FELL AND STRUCK HIM ON HEAD;DX SCALP LAC

190531689 30year old male HAD CEILING FAN FALL ONTO HEAD. NO LOC. DX: HEAD LACERATION

190534847 45YM MOVING FURNITURE HOME WHEN A FAN FELL FROM 4FT HEIGHT STRIKING HEAD W/O LOC YET H/A&NAUSEA SINCE, DX: CONCUSSION

190549199 5MO F CEILING FAN FELL, BOUNCED OFF THE WALL AND THE BED, BLADE HIT ABDOMEN;DX ABDOMINAL CONTUSION

190622032 9YR F SITTING AT HOME UNDER CEILING FAN, PIECE OF LIGHT FIXTURE FELL HITTING HER IN HAND;DX HAND LAC

190625745 18 year old male - A CEILING FAN FELL AND HIT PT ON THE FACE. DX LACERATION

190650411 60year old female CEILING FAN FELL ON HEAD, DX: INJ OF HEAD

190701002 A 46year old female STATES CEILING FAN FELL ON HEAD AT HOME, DX CONTUSION TO HEAD WITH HEMATOMA TO HEAD

190747973 12 year old female - FAN DROPPED ONTO PTS HEAD. DX HEAD INJURY

190804970 65year old male WAS STANDING ON HIS BED WORKING ON A CEILING FAN AND FELL ONTO THE FLOOR DX: CLOSED HEAD INJURY STRAINED NECK

190817677 23year old female PT REPORTS WAS SLEEPING AT A FRIED'S HOUSE WHEN A FAN FELL ON TOP OF HER DX: LAC RT EYEBROW

190840241 52 YO F STATES A BLADE FROM CEILING FAN FELL AND HIT HER ON TOP OF HEAD DX HEMATOMA SCALP

190857912 31 year old male WAS SLEEPING ON HIS STOMACH WHEN A CEILING FAN FELL ON HIS POSTERIOR SHOULDER, C/O SHOULDER PAIN, NO TRAUMATIC INJURY. DX: SHOULDER PAIN

190919502 35year old male PT STS A CEILING FAN DROPPED HITTING HIM ON RT HAND. DX: RT HAND LACERATION

190929754 39year old male HAD A WOODEN BLADE FROM A CEILING FAN FALL ONTO HEAD WHILE AT HIS GIRLFRIENDS HOUSE DX: CLOSED HEAD INJURY

190950625 42year old female PAIN IN NECK INSTALLING A CEILING FAN AT HOME. DX: NECK PAIN

190951511 40 year old male WITH NECK AND BACK PAIN AFTER THE CEILING FAN FELL AND HIT HIM IN THE BACK TONIGHT ABOUT 3 HOURS PRIOR TO ARRIVAL. PT STATES THAT HE WAS JUST LAYING IN THE BED AND IT HIT HIM. DX CERVICAL STRAIN, ACUTE THORACIC Myear old femaleASCIAL STRAIN

190962605 23 year old male HIT ON THE HEAD BY A CEILING FAN THAT FELL ON HIM ONE HOUR AGO, DX: HEAD INJURY

191000407 29year old female WAS AT HOME WITH A CEILING FAN FELL ONTO UPPER BACK AND HEAD DX: CONTUSION TO BACK CLOSED HEAD INJURY

191013492 45year old male WAS INSTALLING A CEILING FAN AND FELL OFF THE LADDER AT HOME DX: RIGHT LOWER LEG PAIN

191016376 59year old female ROLLED OUT OF BED AND HIT HEAD ON FAN/O NOT FEELING WELL DX PERSON W/ FEARED COMPLAINT

191028710 6year old male A FAN AT SCHOOL FELL AND HIT PT IN HIS HEAD. DX CHI AND FOREHEAD CONTUSION

191064043 55year old female C/O SHOULDER AND UPPER BACK HURTS SINCE CEILING FAN FELL ONTO HER. DX SHOULDER AND UPPER BACK CONTUSION

191135383 56year old female FELL TAKING DOWN A CEILING FAN FELL OFF A STEP LADDER DX: FRACTURED THORACIC VERTEBRA

191207804 34 year old male WITH LEFT NECK AND SHOULDER PAIN, PT REPORTS THAT A LARGE CRACK IN HIS CEILING AROUND THE FAN FELL ON HIS LAST NIGHT, DX NECK PAIN LEFT SIDE, ACUTE PAIN OF LEFT SHOULDER

191213587 29year old female WAS AT HOME WHEN A BLADE FROM A CEILING FAN FELL OFF ONTO FACE DX: LACERATION TO FACE

200136653 50year old male. INSTALLING CEILING FAN FELL ON FACE. DX. LAC. RT. EYELID

200248853 43year old female TRIED TO TURN OFF CEILING FAN AND IT FELL ON HER HEAD. DX CLOSED HEAD INJURY, CONCUSSION

200301513 67year old male. CEILING FAN FELL ON HEAD. DX. LAC. HEAD.

2018	2018
CPSC Case #	Narrative
180315431	89year old male EVAL OF R ANKLE, PT STS YESTERDAY MORNING @ 5AM CEILING FAN FELL OFF FROM CEILING & HIT PT IN R ANKLE WHILE HE SLEPT DX R ANKLE PAIN
180349162	17 year old female CEILING FAN FELL ONT HEAD & SHOULDERS 1 WK AGO. HAS INCREASING NECK PAIN. DX NECK CONTUSION; SHOULDER CONTUSION

180440320 64year old male WAS PUTTING UP CEILING FANS IN HIS HOUSE YESTERDAY AND NOW HAS PAIN IN RIGHT SHOULDER DX SHOULDER PAIN

180537938 62year old male HAD A CEILING FAN FALL OUT OF THE CEILING ONTO THE DINING ROOM TABLE AND SHATTER PIECE OF GLASS WENT INTO LOWER LEG LACERATION LOWER LEG

180538758 49year old male-SCALP LAC-30# FAN PART FELL ON PT'S HEAD-LOCATION NS NASAL BONE OPEN FX.

180564056 74 year old female WAS HIT BY A CEILING FAN THAT FELL OUT FROM THE CEILING.

180614243 47 YO MALE HAD A CELING FAN FALL AND HIT HEAD. DX CLOSED HEAD INJURY

180624873 26 year old female CEILING FAN FELL FROM CEILING AND HIT PT DX: FACE LAC

180734576 32 year old male WAS HIT N HEAD BY A CEILING FALN 30 MIN AGO. C/O PAIN IN FOREHEAD. DX MILD CONCUSSION

180736744 9 year old female GLOBE ON CEILING FAN FELL BROKE LACERATED PTS LOWER LEG

180745122 32year old male PT STS HE WAS WORKING ON A FAN WHEN IT FELL HITTING LEG. DX: RIGHT ARM LACERATION.

180825547 69 YR OLD FEMALE HAD A FAN FALL ONTO HER LEG WITH SKIN TEAR TO LOWER LEG

180831642 14year old female WAS HIT IN THE HEAD BY BEDROOM CEILING FAN, NO LOC, CEILING FAN BLADE FELL AND HIT HIM IN THE HEAD, DX BLUNT HEAD INJURY;

180856312 A 3year old male WAS SITTING AT TABLE, CEILING FAN FELL ON HEAD, CONTUSION TO HEAD

181027614 11 YO M PT PLAYING IN HIS ROOM WHEN THE CEILING FAN FELL OFF THE CEILING LANDED ON PT CUTTING RT UPPER ARM DX 2CM LAC RT HUMERUS

181029186 16 year old male INJURED HEAD,WHILE IN BED,CEILING FAN FELL ON HIM,AT HOME, 2 WEEKS AGO. DX-CLOSED HEAD INJURY,CONCUSSION

181035707 47 year old female PT WAS STANDING ON A BED INSTALLING A CEILING FAN & LOST BALANCE& FELL OFF LANDING ON SHOULDER DX RIGHT SHOULDER PAIN

181039139 20YM RTS A FAN FELL ONTO HIS HEAD WHILE SLEEPING 1WA>>CHI
 181246223 28year old male INTALLING A CEILING FAN AND IT FELL HITTING HEAD. / SCALP LAC
 181249230 27year old female PAIN IN SHOULDER WHEN CEILING FAN FELL ONTO PATIENT AT HOME. DX: RT SHOULDER PAIN

2017 CPSC Case #	2017 Narrative
170125189	LT SHOULDER STR. 25year old male CEILING FAN FELL ON SHOULDER AT HOME.
170332472	HIP CONT. 52year old female BEDROOM CEILING FAN FELL ONTO PATIENT WHILE SLEEPING AT HOME.
170332473	CHI. 45year old female BEDROOM CEILING FAN FELL ONTO HEAD WHILE SLEEPING AT HOME.
170339774	28YF RTS THE LANDLORD CHANGED CEILING FAN THAT CONTAINED GLASS LIGHT WHICH FELL ON TOP OF HER HEAD&IT SHATTERED C/O H/A&LHD'NESS>>CONCUSSION
170538937	19 MO FEMALE INJURED HEAD, CEILING FAN FELL ON HEAD. DX-CONTUSION SCALP
170543168	39 year old male UPPER BACK CONTUSION, CEILING FAN FELL HITTING HIS BACK
170544041	CLOSED HEAD INJURY 27year old female FAN FELL ONTO HEADDX: CHI
170553902	4year old female LAC HEAD- CEILING FAN FELL ON HEAD
170569130	15year old female NS INJ FACE- CEILING FAN FELL ON PT
170739878	60year old male ARRIVES C/O SHOULDER PAIN, PUTTING UP CEILING FAN, FELL DOWN 4FEET, HURT SHOULDER DX-CONTUSION RT SHOULDER FALL
170740295	11year old male-PT TRYING TO FIX CEILING FAN WHEN THE GLASS PORTION FELL ONTOFACE IMMEDIATE BLEEDING. DX- 7.5CM FOREHEAD LACERATION.
170832679	46 year old male HEAD & NECK PAIN AFTER HAVING A CEILING FAN FALL ON HEAD TODAYAT HOME. DX CERVICAL STRAIN, CLOSED HEAD INJURY
170834181	A 16year old male STATES CEILING FAN FELL AND GLASS LITE COVER BROKE, LAC TO HAND

170851999 22 year old female INJURED HEAD, CEILING FAN FELL ON HEAD WHILE IN BED AT HOME. DX-
CLOSED HEAD INJURY

170853779 47year old female LAC FACE- MAKING BED, CEILING FAN FELL ON PT

170872595 62year old female REPORTS CEILING FAN FELL ON RT SIDE OF FACE. DX: RT EYE AND FACEPAIN.*

170916472 5month old male month old male SMELLED ELECTRICAL SMOKE COMING FROM PTS BEDROOM
THE CEILING FAN WAS SMOKING ROOM FILLED WITH SMOKE- TO ED FOR POSSIBLE SMOKE
INHALAT

170954722 12year old male WAS LYING ON HIS STOMACH ON BED WHEN A CEILING FAN FELL HITTING PT IN
BACK OF HEAD DX: HEAD LACERATION

171011622 63year old female HAD A SECTION OF A CEILING FAN FALL ONTO HEAD AT HOME CLOSED
HEADINJURY

171030985 14 year old female - CEILING FAN FELL ON PT. DX WRIST CONTUSION

171041926 61 year old male C/O HEAD & NECK PAIN AFTER CEILING FAN FELL ON HIM THIS AM.DX
CONCUSSION, CERVICAL STRAIN, CONTRUSION OF LT SHOULDER

171104924 36 year old female C/O DIZZINESS, LIGHTHEADEDNESS AND HEADACHE SINCE A FAN FELL STRILING
HER HEAD 5 DAYS AGO. DX CLOSED HEAD INJURY

171218478 CT,COCCYX.71year old female.WHILE WALKING GOT TANGLE WITHF CABLE OF FAN FALLING DOWN
ON FLOOR

2016	2016
CPSC Case #	Narrative
160112322	17year old female WAS SITTING AT HOME AND A GLOBE FROM A CEILING FAN FELL AND HIT PTIN HEAD. HEAD INJURY*
160201019	47year old female SAW CEILING FAN FALLING AND PUT HAND UP TO BLOCK IT DX SPRAIN WRIST

160213484 61year old male STANDING ON A STOOL HANGING A CEILING FAN AND FELL OFF LACERATION TO FACE

160360022 40year old female AT HOME STS CEILING FAN FELL ON PTS HEAD SAW SPOTS WHEN IT HIT NLOC DX NECK STRAIN HEADACHE

160402495 40 year old female CEILING FAN FELL ON PT AT HOME DX; FOREHEAD LAC

160420785 15year old female CEILING FAN FELL ON HER; DX CHI, LAC FOREHEAD

160446536 42 YO F WAS TRYING TO REPAIR A CEILING FAN WHEN IT FELL ONTO HER HEAD/FACE AND ARM DX HEAD INJ/LAC

160543849 25 YR OLD MALE HAD CEILING FAN CATCH FIRE AND PULLED IT DOWN BURNING HANDS, UNK IF FIRE DEPT ATTEND

160550759 16 year old male HAD CEILING FAN FALL ONTO KNEE DX CONTUSION

160614263 55 year old female - CONCUSSION - CEILING FAN FELL AND HIT PT IN HEAD

160653230 12year old female HAD A PIECE OF A CEILING FAN FALL ONTO HEAD AT HOME CLOSED HEAD INJURY

160653844 31year old male WITH HEAD INJURY AFTER A FAN FELL ON PT DX HEAD INJURY*

160704286 2 YO F PER month old male SHE WAS IN KITCHEN HEARD LOUD NOISE SAW THAT A LARGE FAN HAD FALLEN ON THE PT AND CUT HER DX LT CHEEK LAC

160710135 9 year old male - A BLADE OF A CEILING FAN FELL AND HIT PTS HEAD. DX HEAD INJURY

160728421 CEILING FAN FELL ON PT'S HEAD. HEAD CONTUSION. 45 year old female*

160733450 2 month old female - FAN FELL ON PTS HEAD. DX HEAD INJURY

160812800 16month old female-PT WAS HOME WHEN LIGHT /CEILING FAN FELL ONTO FOREHEAD NO LOC N/V. LACERATION TO FOREHEAD. DX- 2CM FOREHEAD LACERATION.

160821384 4year old male LAC HEAD- GLASS LIGHT GLOBE FIXTURE FELL FROM CEILING FAN ONTO PT

160849617 28 YO M TRAUMA ALERT S/P CEILING FAN FELL ON HIS HEAD SHOULDER LOC DX FOREHEAD RT SHOULDER ABRASIONS

160853324 26year old male REPORTS THAT CEILING FAN FELL AND HIT HIM ON HEAD. HAS HEAD PAINNOW. LWOT. *

160857622 26 year old female DX LACERATION TO FOREHEAD - DUE TO FALLING CEILING FAN TODAY.

160942759 21 year old female WAS SITTING IN HER KITCHEN WHEN A CELING FAN FELL AND STRUCK HERHEAD C/O HEAD AND NECK PAIN DX CERVICAL STRAIN

160943402 70year old female HANGING A CEILING FAN AND FELL OFF THE LADDER AND SUSTAINED A CLAVICLE FX

161001944 LAC.HEAD.57year old female.REFERS A CEILING FAN FELL ON HEAD WHILE IN BED.

161005808 40 year old male DX SCALP LACERATION - S/P PT STOOD ON WASHING MACHINE INLAUNDROMAT WHEN CEILING FAN HIT HEAD.

161014365 44 year old male WAS HANGING A CELING FAN AT HOME AND FELL OFF LADDER LANDING ONLT SHOULDER. DX SHOULDER DISLOCATION @

161117756 4year old female HIT HEAD ON CEILING FAN; DX LAC FOREHEAD

161132359 46 year old female. SITTING IN HER SON'S CLASSROOM & THE CEILING FAN FELL ON PT FACE,LAC & NOSE SWELLING. DX: CLOSED FX OF NASAL BONE

170100833 55 year old female REPORTS CEILING FAN FELL ON HEAD & LATER SHE FELL DOWN SOME STAIRS & "PEOPLE" FELL ON TOP OF HER, CAUSING HEAD PAIN. DX HEAD INJURY/

2015	2015
CPSC Case #	Narrative
150140897	58 year old male NECK, SHOULDER, BACK PAIN. YESTERDAY PUT UP CEILING FAN. HAD ARMS ABOVE HEAD AND NECK BENT MOST OF DAY. DX: MUSCLE SPASM
150238105	21year old female-FACIAL AB-CUT WHEN A CEILING FAN FELL FROM CEILING-@ HOME

150432012 48 year old female CEILING FAN FELL, HIT PT, KNOCKED HER OUT OF CHAIR DX: NECK CONTUSION
150600442 72year old male TRYING TO HANG A CEILING FAN AT HOME AND SUSTAINED A FOREARM
LACERATION
150604880 33 year old female CEILING FAN FELL, HIT PT IN FACE DX; OPEN NOSE FX
150607319 PT STUCK HAND IN FAN. LACERATION HAND, RIGHT, COMPLICATED. 21 month old female*
150609233 R EYEBROW LAC/27YOWM AT HOME WAS ATTEMPTING TO INSTALL A CEILING FAN AND THE
BLADE OF THE FAN STRUCK HIM CAUSING LACERATION.
150614890 54year old male WITH 2ND AND 1ST DEGREE BURNS TO UPPER BODY AFTER CEILING FAN STARTED
A FIRE AND WALLS IN HOME WERE BURNING. FIRE DEPARTMENT RESPONDED.
150640946 11year old female-PT HAD A LARGE FAN THAT FELL FROM HEIGHT 10-12 FEET HITTING PT TOTHE
HEAD. DX- CHI.
150658269 24 year old female WAS CLEANING CEILING FAN AT HOME WHEN IT FELL ONTO HERSHOULDER DX
CONTUSION
150662048 PT WAS WORKING ON A CEILING FAN AND FELT A PULL. LOW BACK PAIN.43 year old male*
150728242 49year old female LAC F'HD- FAN FELL FROM CEILING
150728355 81year old male LAC TO UPPER LIP WHEN CEILING FAN FELL HITTING PT IN FACE. DX LIPLAC
150728875 13 year old male WAS EATING AND CEILING FAN BLADE FELL AND HIT HIS HEADDX CONCUSSION
150803450 HAND ABR 9year old male MOVING FAN FELL INTO GLASS AT HOMEDX: ABR HAND
150822901 79year old female LAC HEAD- LIGHT FIXTURE FELL FROM CEILING FAN
150822955 28year old male STR NECK- INSTALLING CEILING FAN, FELL 4' FROM LADDER
150822988 36year old male FX RIBS- INSTALLING CEILING FAN, FELL ON TABLE
150847403 59YM UP ON A LADDER TRYING TO HANG A FAN WHEN FELL OFF STRIKING HEAD ONTO PIECE OF
WOOD NO LOC>>CHI/LAC
150860118 41YM RTS A FAN FELL OFF THE CEILING HITTING HIS HEAD>>LAC

150860338 22YM WAS CHANGING CEILING FAN, FORGOT TO TURN OFF POWER, GRABBED A WIRE&FELT A SHOCK C/O HAND N&T/HA>>ELECTRIC SHOCK

150921508 37 year old male LAC TO HEAD WHEN CEILING FAN FELL FROM THE CEILING AND HIT HIM

150924235 60year old male WSHOULDER & HAND PAIN 2/2 FAN THAT FELL FROM CEILING HIT HIS SHOULDER & THEN HE FELL ON HIS SHOULDER.

151007421 76year old male STANDING ON A STEP LADDER TAKING DOWN CEILING FAN. FAN FELL AND PT FELL ON TOP OF IT CUTTING EAR. / EAR LAC

151055928 80year old female AT THE FLEA MARKET WHEN A PIECE OF THE CEILING FAN CAME DOWN ONTOHEAD LACERATION TO SCALP

151058126 63year old female AT HOME WHEN CEILING FAN WITH LIGHT FIXTURE FELL ON HEADDX HEAD INJURY, HEAD PAIN, ABRASION

151143412 48year old female STATES A LIGHT FIXTURE FROM CEILING FAN FELL & HIT TOP OF HEAD. DX; HEAD INJURY

151219137 LAC.LT.EAR.57year old female.CEILING FAN FELL HITTING EAR

151226435 FRAC LOW TRUNK 56year old male PUTTING UP FAN FELL OFF LADDER AT HOMEDX: FRAC HIP

151230025 10 year old male WAS AT COUSIN'S HOUSE & WAS LAYING IN THE LIVING ROOM WHEN THECEILING FAN LIGHT COVER FELL OFF & HIT HIM IN HEAD- VOMITED. DX; CHI

151243534 56year old female CONT HEAD - CEILING FAN FELL FROM CEILING

151243823 82YF SENT IN FROM ECF C/O H/A P GOT HIT BY FALLING LIGHT FIXTURE FROM THE FAN TO HEAD NO LOC>>CHI

151247421 12year old male AT HOME STS CEILING FAN FELL OFF BRACKET & HIT PT ON R SIDE OF HEAD DX HEAD INJURY

160222186 49year old male RAN INTO BURNING HOME TO SAVE PEOPLE AND THE CEILING COLLAPSED AND A CEILING FAN FELL ON HIM. +LOC. DX SMOKE INHALATION, ?FD ON SCENE.

2014 CPSC Case #	2014 Narrative
140309768	26year old male CHANGING A CIELING FAN AND FELL 8 FEET OFF A LADDER ONTO HEAD SKULL FX
140404086	37year old male WITH CHI FROM A FALLING FAN
140431646	73YO M WAS ON LADDER WORKING ON CEILING FAN WHEN FELL OFF LADDER. DX:SUBARACHNOID HEMORRHAGE. ADMIT.
140455467	32year old male FELL OFF LADDER WHILE PUTTING UP CEILING FAN AT HOME CHEST CONTUSION
140459978	24year old female WITH FOREHEAD LAC 2/2 CEILING FAN FALLING ON HER TODAY. NO LOC.
140522693	59 YO M, C/O LT NECK, SHOULDER PAIN S/P CEILING FAN FALLING ONTO LT SHOULDER, DX LT SHOULDER PAIN
140532910	67year old female SITTING IN A RESTAURANT WHEN A PIECE OF A CEILING FAN FELL ONTO EHAD CLOSED HEAD INJURY
140533352	87year old male FELL & A FAN FELL ONTO CHEST C/O RIB PAIN DX: RIBS CONTUSION
140605800	LT CORNEA ABRASION. 82year old female GLOBE FROM CEILING FAN FELL OUT AND SCRATCHED EYE.
140606131	A 10year old female STATES CEILING FAN FELL ON HEAD, DX HEAD INJURY
140621518	5year old female PT COMPLAINING OF FOREHEAD CONTUSION AFTER A CEILING FAN FELL ONPT'S FOREHEAD AT HOME DX CONTUSION#
140662507	59YM FROM GROUP HOME AFTER CEILING FAN FELL STRIKING HIS BACK, PT DENIES PAIN>>MED EVAL
140667358	70 YR OLD MALE TAKING DOWN A FAN AND EXTENDED NECK STRAINING IT
140703104	DX SCALP CONTUSION 38year old female FAN FELL ON TOP OF PATIENT'S HEAD DIZZY/NAUSEA
140712492	88 year old female DISTAL RADIUS FX. PT WAS AT HOME WHEN HER CEILING FAN FELL HITTING HER WRIST, SPLINT APPLIED F/U ORTHO

140801604 7 year old male MOTHER STATES A BLADE FROM CEILING FAN FELL OFF A FEW DAYS AGO IT WAS LEANING AGAINST WALL PT FELL LANDED ON BLADE DX LACERATION HAND

140835976 68YR OLD MALE PUTTING UP A CEILING FAN AND STRAINED NECK WITH SPASM

140907489 62 YM INJURED TOE WHEN A CEILING FAN FELL ON LEFT FOOT. DX TOE LAC

140967705 46year old male LAC HAND WHILE INSTALLING CEILING FAN

141011313 19 year old female LAC TO FACE WHEN STRUCK BY A CEILING FAN

141104132 64year old male HAD A CEILING FAN FALL ON HEAD, CONCUSSION, AND SCALP CONTUSION

141217642 21 year old female LAC TO HEAD WHEN CEILING FAN FELL AND HIT HEAD

150216298 69year old female HAD A FAN FALL ONTO HEAD LACERATION TO SCALP

2013

CPSC Case #

2013

Narrative

130159875 57 year old male DEVELOPED PAIN TO NECK & SHOULDER S/P HANGING A CEILING FAN ON THE CEILING LAST WEEK.*

130339950 54 year old female SUSTAINED A LACERATION OF THE SCALP FROM BEING STRUCK BY A FALLING FAN ABOUT THE WORKSHOP DOOR.

130348393 10month old female HAD CEILING FAN FALL ONTO HEAD AT HOME CLOSED HEAD INJURY

130441724 57YM REPORTS A CEILING FAN FELL ON TOP OF HIS HEAD NO LOC>>CHI/LAC

130508409 47 YO M WITH LOW BACK PAIN WHICH BEGAN WHILE HANGING CEILING FANS ON CEILING AT HOME. DX:LOW BACK MUSCLE STRAIN.

130633247 54year old male LOOKING UP AT A CEILING FAN THAT WAS WABBLING AND FELL ONTO FACE LACERATION FACE

130713056 53year old female GOT HIT BY FALLING FAN DX: CONTUSION TO SHOULDER

130716773 24 YO M, C/O CEILING FAN FALLING ON HIS HEAD WHILE HE WAS REMOVING IT FROM CEILING, FELL OFF LADDER (5 FT), NO LOC, DX SCALP LACERATION

130743728 67year old female HANDING CEILING FAN TO FRIEND ON LADDER;FRIEND FELL ONTO PTLAC LT ELBOW DX: LAC/CONTUS ELBOW

130743737 78year old male INSTALLING FAN, FELL OFF LADDER;LANDED ON FRIEND; C/O LOW BACKPAIN DX: BACK CONTUSOIN

130751372 47year old female WITH HEAD INJ 2/2 HER CEILING FAN FALLING AND HITTING HER IN THEHEAD. NO LOC. REPORTS DIZZINESS & SEEING SPOTS.

130842821 47year old male WITH CHI FROM A FALLING FAN

130844229 37 year old female WAS AT A PARTY AT A PUBLIC FACILITY AND A CEILING FAN FELL ONTOHER HEAD, DX: CHI

130901274 43 YO M, S/P ACCIDENT W/ CEILING FAN FALLING ON HIS HEAD YESTERDAY AT 8PM, HAD BLEEDING INITIALLY, DX SCALP LACERATION

130917238 57 year old female C/O FAN FALLING AND STRIKING HER IN HEAD. DX FOREHEAD LAC

130938185 PAIN UP TRUNK 82year old female CEILING FAN IN HOUSE FELL STARTLING HER AT HOMEDX: CHEST PAIN

130945163 37 year old female STATES A CEILING FAN FELL ON HER TOEDX:FRACTURE TOE

131129265 22year old male-CONCUSSION-A FAN MOTOR FELL HITTING PT'S HEAD-@ HOME

131221372 15year old male WITH THUMB LACERATION AFTER TRYING TO CATCH FALLING FAN DX THUMBLACERATION **

140101020 33 Year old female WAS AT HOME AND THE CEILING FAN FELL ON HER. DX LOW BACK PAIN

Relevant Incidents involving Ceiling (Paddle)

Fans 2022-2013

Public Input 2484

This report contains the narrative reports of incidents involving injuries from ceiling (paddle) fans. These reports come from the National Electronic Injury Surveillance System (NEISS), which is maintained by the Consumer Product Safety Commission. According to the NEISS Coding Manual, “The primary purpose of NEISS is to provide timely data on unintentional consumer product-related injuries and deaths occurring in the U.S. NEISS injury data are gathered from the emergency departments (ED) of 96 hospitals selected as a probability sample of all U.S. hospitals with 24-hour EDs and at least 6 inpatient beds. Each participating NEISS hospital is hand-selected by CPSC

because it provides an important representation of all other hospitals of its size and unique characteristics in the U.S.”(January 2022, P.1) It is important to note that at the end of 2021, there were 6,129 hospitals in the US (<https://www.statista.com/statistics/185843/number-of-all-hospitals-in-the-us/#:~:text=This%20statistic%20shows%20the%20number,2021%2C%20there%20were%206%2C129%20hospitals>). In addition, there are approximately “10,800 active urgent care clinics in the US” (<https://www.definitivehc.com/resources/healthcare-insights/urgent-care-clinics-us#:~:text=According%20to%20data%20from%20Definitive,urgent%20care%20clinics%20per%20capita.>). This strongly indicates that the number of injuries is much higher.

The primary goal of admitting personnel is to collect the necessary information to begin treatment. It is important to understand that some incidents may simply be classified as falls, without a relation to a consumer product because the additional detail may not be considered clinically important. In fact, the data collected by CPSC focuses primarily on injuries caused by consumer products. Therefore, falls may not appear with complete details in these statistics. A few of the incidents that are included in this report involve pieces of fans falling on occupants. Such incidents likely occurred because the installation was not as robust as it needed to be, allowing parts to loosen and fall.

This report does not include workplace injuries. Workplace injury data is collected by the National Institute of Occupational Safety and Health.

There are a number of incidents involving injuries to occupants of bunk beds. There are also incidents involving injuries to children who threw some object at a fan. Such incidents are excluded from this report, because they are not germane to this public input.

Relevant Incidents involving Ceiling (Paddle) Fans 2022-2013

2022

2022

CPSC Case

Narrative

220419511 25year old male PRESENTS WITH EVALUATION AFTER HEAD INJURY. PATIENT STATES HE WAS STANDING NEAR A DOOR WHEN SUDDENLY PART OF THE CEILING FELL AND CEILING FAN STRUCK HIM IN THE TOP OF HIS HEAD CAUSING HIM TO FALL BACKWARDS. DX: STRAIN OF MUSCLE,FASCIA AND TENDON AT NECK LEVEL. SPRAIN OF INTERPHALANGEAL JOINT OF UNSPECIFIED FINGER.

220348929 41 year old male REPORTS A FAN FELL AND STRUCK HIM IN THE THUMB.DX: LACERATION OF LEFT HAND

220361987 27 year old male ELECTROCUTED AT HOME WHILE TRYING TO INSTALL A CEILING FAN, TRIED TO TURN ON WHILE THE OTHER HAND WAS TOUCHING DISHWASHER. DX ELECTROCUTION ACCIDENT, CHEST STRAIN

220547269 64year old male C/O FOREIGN BODY. PT WAS SLEEPING & CEILING FAN FELL DOWN ONTO HIM.

THE BULB BROKE OVER HIS LEG. DX: MULTIPLE ABRASIONS, LLE LAC, KNEE CONTUSION

220567703 69year old female, TO ER AFTERFALL AT HOME, PT REACHING FOR FAN & FELL HITTING HEAD ON FLOOR, PT SUSTAINED LACERATION OF CHIN, & SKIN TEAR TO BILAT FOREARMS PT HAS BUMP ON BACK OF HEAD, NO LOC, PT IS ON ***, PT HAS SOME NAUSEA, FALL OCCURED 1 HR AGO, NO DIZZINES & WAS ABLE TO GET SELF UP HERSELF DX FALL, CHIN LACERATION, SKIN TEAR TO BILATERAL FOREARMS

220571365 69 year old female STATES THAT A CEILING FAN FELL ON HER IN FEBRUARY 2022, AND HAS SINCE BEEN EXPERIENCING DIZZINESS AND FEELINGS OF BEING OFF-BALANCE. DX CHRONIC CONFUSION, CHRONIC BALANCE PROBLEM, CHRONIC VISUAL DISTURBANCE

220600649 52year old female HAD A CEILING FAN FALL ONTOP OF RIGHT FOOT DX: CONTUSION TO FOOT

220616691 59year old female, UP ON A TABLE TRYING TO FIX CEILING FAN WHEN FELT DIZZY, STEPPING DOWN ON A CHAIR WHICH BROKE UNDERNEATH HER WEIGHT AND FELL, +ECCHYMOSSIS TO THIGH
DX: FALL, INTIAL ENCOUNTER; NEARSYNCOPE; LEFT WRIST PAIN; LEFT LEG PAIN

220727044 46year old female PRESENTS AFTER A CEILING FAN FELL ON HER HEAD WHILE SHE WAS AT A LAUNDROMAT. SHE HAS LACERATION TO HER RIGHT FOREHEAD. DX: FOREHEAD LACERATION

220868992 55 year old female WAS HIT ON THE KNEE BY A FALLING FAN. DX: LEFT KNEE CONTUSION.

220900699 32year old female PT REACHED UP TO STABILIZE A BROKEN FAN WHEN SHE WAS ELECTRICAL SHOCK TO HAND. DX: ACUTE RIGHT HAND ELECTRICAL INJURY.

220961902 47year old male PT WAS AT HOME UP ON A LADDER HANGING CEILING FAN LOST BALANCE FALLING HITTING LEFT HEAD ON CEMENT. DX: FALL, HEAD INJURY.

220751022 47year old female HAD A CEILING FAN FALL ON HEAD. DX SHOULDER PAIN, NECK PAIN

220949006 34year old female PT HAD THE CEILING FAN FALL ONTO HER RT LOWER LEG AND FOOT HURT TOE PAINFUL DX FRACTURE RT GREAT TOE, CONTUSION RT LOWER LEG

220822776 38year old female, STANDING ON A LADDER HELPING BOYFRIEND PUTTING A FAN WHEN FELL DX: RIGHT WRIST SPRAIN

220839695 31year old male,A CEILING FAN FELL OFF THE CEILING AN HIT HIM ON BACK,DX:LAC BACK

220867719 47year old male, STANDING ON THE BED TRYING TO HOOK A CEILING FAN AND FELL OFF AGAINST A CHAIR DX: HEMATOMA OF BUTTOCK

220925332 58year old male WAS HIT IN THE HEAD BY A FALLING PIECE OF A CEILING FAN. DX: HEAD TRAUMA, CONCUSSION

220926009 9month old male STRUCK BY GLASS LIGHT FIXTURE GLOBE THAT FELL OFF CEILING FAN. DX: HEAD INJURY, FACIAL LAC

220960075 57 year old male WAS CHANGING OUT A FAN, DROPPED IT AND CUT HIS R HAND 5TH DIGIT, "TO THE BONE." DX: LEFT WITHOUT BEING SEEN

221007001 18 month old male - PART OF CEILING FAN FELL AND HIT PT ON THE HEAD. DX HEAD INJURY

221014739 25year old female HAD A CEILING FAN FALL HITTING HER IN THE HEAD. DX: CLOSED HEAD INJURY, NECK PAIN

221020990 25year old female HAD A CEILING FAN FALL HITTING HER NECK, DX: CONTUSION NECK

221021003 52year old male HAD A CEILING FAN FALL NEAR HIM AND A PIECE BROKE OFF AND HIT HIM IN THE RT EYE. DX: TRAUMATIC IRITIS

230200510 35year old female STS A CEILING FAN FELL ON HEAD AT LAUNDRY MAT C/O NECK PAINDX ACUTE TORTICOLLIS

221007169 83year old female WITH INJURY TO HEAD, HER HUSBAND WAS STANDING ON THE BED WORKING ON A FAN, HE FELL AND HIT PATIENT'S HEAD WITH HIS HEAD.DX: CONTUSION WITH SOFT TISSUE HEMATOMA SCALP.

221007170 80year old male WITH FALL AT HOME, STANDING ON BED WORKING ON A CEILING FAN, FELL OFF BED AND HIT FLOORDX: LAC. SCALP; SOFT TISSUE HEMATOMA SCALP

221029830 8year old female PIECE OF CEILING FAN BROKE & FELL ON PT. DX: ABR FACE

221168661 71year old female WAS SITTING IN HER WHEELCHAIR AT HOME WHEN CEILING COLLAPSED AND CEILING FAN LANDED ON PT. DX:CLOSED COMPRESSION FX L4 AND WEDGE COMPRESSION FX, L3, ACUTE NECK AND BACK PAIN.

221227240 2year old male PRESENTS AFTER A CEILING FAN FELL BESIDE HIM, CAUSING MULTIPLE LACERATIONS TO HIS RIGHT FOREARM. DX: LACERATION OF MULTIPLE SITES OF RIGHT UPPER EXTREMITY

221210342 74 year old male CEILING FAN FELL ON HEAD DX; SCALP LAC

2021

2021

CPSC Case #

Narrative

210123158 23year old female HAD A CEILING FAN FALL ONTO HER HEAD AT HOME DX: CLOSED HEAD INJURY;
LACERATION SCALP

210127852 48 year old male INJURED HAND,FELL OFF LADDER,CHANGING CEILING FAN,AT HOME. DX-
CONTUSION LEFT HAND

210147668 41year old male ELECTRICAL INJURY TO HAND WHILE CHANGING A CEILING FAN AT HOME. DX:
LOW VOLTAGE ELECTRIC SHOCK HAND, LEFT HAND PARASTHESIA.

210148674 13 year old female AT HOME WHEN A CEILING FAN FELL ONTOP OF HER C/O SHOULDER PAIN DX
SHOULDER INJURY

210202412 53 year old female INJURED HEAD,NECK,CEILING FAN FELL ON HEAD WHILE PATIENT WAS LAYING
IN BED,AT HOME. DX-TRAUMATIC HEAD INJURY,INJURY NECK

210211645 68year old male WAS WORKING ON A CEILING FAN AND FELL OFF THE LADDER DX: SPLEEN
FRACTURE

210222909 8month old male JHAD A SECTION OF THE CEILING FAN FALL ONTO FACE WHILE SLEEPING IN
month old maleS BED DX: LACERATION TO FACE

210232864 39year old male WAS HANGING A CEILING FAN AT HOME AND IT FELL ONTO HEAD DX: CLOSED
HEAD INJURY LACERATION TO SCALP

210233092 44year old female WAS AT HOME WHEN A FAN CAUGHT ON FIRE SHE INHALED THE SMOKE AND
DEVELOPED COUGHING NO COHGB DRAN NS IF FD ON SCENE DX: SMOKE INHALATION

210303893 73 year old male FIXING CEILING FAN AND FELL FROM LADDER HIT HEAD ON NIGHTSTAND DX CHI

210307324 88year old male WAS TRYING TO HANG A CEILING FAN ON THE CEILING AND DEVELOPED PAIN IN
RIGHT SHOULDER DX: RIGHT SHOULDER STRAIN

210342628 9year old male CEILING FAN FELL ONTO PT; DX: CHI, SCALP LAC

210343317 59 year old female HIT HEAD ON CEILING FAN AT HOME IN KITCHEN DX SCALP LACERATION

210350387 48year old male PT HANGING UP A CEILING FAN, FELT POPPING/SNAPPING SENSATION IN RT SHOULDER DX: ACUTE SHOULDER PAIN #

210357241 34year old female WAS ON A LADDER HANGING A CEILING FAN ON THE CEILING AND IT FELL AND LACERATED HER LEFT EYEBROW DX: FACIAL LACERATION

210416920 30year old male WAS SITTING O HIS COUCH WHEN A CEILING FAN FELL ONTO HIS HEAD DX: CLOSED HEAD INJURY

210417621 45 year old male STANDING ON LADDER TO INSTALL CEILING FAN, HURT BACK. DX LS STRAIN

210448460 47year old female HAD A CEILING FAN FROM HER KITCHEN FALL ON HER HEAD DX: CLOSED HEAD INJURY

210507955 57year old female CEILING FAN FELL ONTO RIGHT HAND DX: LACERATION TO HAND

210511950 53year old male WHILE PUTTING FAN UP,FELL OFF LADDER--DX:FX SHOULDER+RIB

210534932 21 year old male WAS STANDING ON A BED PUTTING UP A CELING FAN WHEN HE FELL OFF OF THE BED LANDING ON OUTSTRETCHED RIGHT ARM. DX: RIGHT SHOULDER PAIN S/P FALL, SUSPECTED ROTATOR CUFF INJURY

210538106 37year old male HAD A CEILING FAN FALL ONTO HEAD. DX: CHI

210616701 29 year old male. PT C/O OF FOREHEAD PAIN AFTER CEILING FAN FELL FROM CEILING AT HOME. DX: SCALP CONTUSION

210616702 10 year old male. PT C/O HEAD PAIN AFTER CEILING FAN FELL FROM CEILING AT HOME. DX: SCALP CONTUSION

210631134 40year old male WAS HANGING A CEILING FAN AND IT FELL ONTO FACE DX: NASAL FRACTURE

210638703 44 year old male WAS INSTALLING A CEILING FAN AND HAD IT RESTING ON TOP OF A LADDER; IT FELL OFF THE LADDER STRIKING HIM ON THE HEAD +HEADACHE DX CHI, SCALP HEMATOMA, SUPERFICIAL LAC

210715623 62 year old male. HEAD INJURY AFTER A CEILIGN FAN FELL & HIT HIM ON THE TOP OF THE HEAD.

DX: CLOSED HEAD INJURY; SCALP LAC

210721503 64year old female, A CEILING FAN, FELL OFF THE CEILING STRIKING HEAD WITHOUT LOSS OF CONSCIOUS, DX: LACERATION OF SCALP; MINOR HEAD INJURY

210741839 32year old female WAS WALKING TO HER ROOM WHEN THE CEILING AND CEILING FAN COLLAPSED ONTO HER HEAD DX: NECK PAIN

210844629 45year old female WAS IN AN APARTMENT FIRE WHEN AN ELECTRICAL FAN CAUGHT FIRE INHALED THE SOKE AND STARETD TO COUCH AND WHEEZE COHGB OF 3 FD WAS ON SCENE DX: SMOKE INHALATION

210847909 31 year old female CEILING FAN FELL ON HEAD DX: SCALP CONTUSION

210865407 44year old female HAD A CEILING FAN FALL ONTO HEAD DX: CONCUSSION

210926430 10year old female HAD A CEILING FAN FALL ONTO HER NOSE. DX: NOSE SWELLING; LWBS

211052894 88 year old male HAD A CEILING FAN FALL AND HIT HIM ON THE HEAD. DX: CLOSED HEAD INJURY.

211066278 52year old male PATIENT PUTTING UP A CEILING FAN ON 6 FOOT LADDER AND LOST BALANCE FALLING HAVING LEFT RIB PAIN, LEFT ELBOW EFFUSION DX: RIB FRACTURE, ELBOW INJURY, ACCIDENTAL FALL FROM LADDER

211200580 21year old male PT WAS AT HOME WHEN A CEILING FAN FELL HITTING SHOULDER. DX: SHOULDER PAIN.

2020

2020

CPSC Case #

Narrative

200105581 48year old male WITH BACK PAIN AFTER FALLING OFF OF LADDER WHILE TRYING TO INSTALL A CEILING FAN, WAS APPROX 4 STEPS UP WHEN HE LOST HIS BALANCE AND FELL BACKWARDS STRIKING A WINDOWSILL ON LOWER BBACK, DX: ACUTE ON CHRONIC LS BACK PAIN

200138673 29year old male WAS TRYING TO HANG A CEILING FAN AT HOME WHEN IT FELL ON HIM. DX: CERVICAL STRAIN, THORACIC STRAIN.

200153632 50 year old female HX OF MS CEILING FAN FELL ON HEAD, PRESENTS WITH CONFUSION, HEAD PAIN. DX: HEAD PAIN

200315385 64 year old male C/O SHOULDER PAIN S/P REACHING UP TO INSTALL A CEILING FAN AT HOME. DX: SHOULDER PAIN

200529122 25year old male CUT TO [R] RING FINGER FROM CEILING FAN; HE WAS CHANGING IT FELL; DX: [R] RING FINGER LACERATION

200427815 1month old female CELING FELL IN BECAUSE OF WATER LEAKAGE AND THE CEILING FAN FELL ONTO PT. DX EYE? INJURY

200502133 80year old male WAS ON A LADDER WORKING ON A FAN AND FELL OFF DX: LEFT HIP FX

200719409 68year old male.FALLING DOWN FROM LADDER INSTALLING CEILING FAN.DX.HEAD TRAUMA AND,CONT.LT.ANKLE

200648912 8year old male WAS HIT ON THE RIGHT SHOULDER WHEN A CEILING FAN FELL. DX: SHOULDER LACERATION.

200737210 29year old female TWISTED NECK TRYING TO CATCH FALLING FAN, DX: NECK PAIN

200804044 79 year old male FELL YESTERDAY WHILE TRYING TO MOUNT A KITCHEN FAN, FELL OFF CHAIR HE WAS STANDING ON HITTING HIS HEAD AND FACE, DX: ACUTE HEAD INJURY, FACIAL ABRASION, FRACTURE TRANSVERSE LUMBAR VERTEBRA

200805056 45year old male WAS AT HOME AND HIS CEILING FAN FELL ON HIM. DX NECK AND BACK PAIN

200828084 7year old female HAD CELING FAN ACCDIENTALLY FALL ON HER HEAD AND FACE. DX FACIAL LACERATION@

200906426 19year old male PRESENTS AFTER A CELING FAN FELL AND HE INHALED SOME DUST PARTICLES AND EXPERIENCED CHEST TIGHTNESS AND WHEEZING, DX: MILD INTERMITTENT ASTHMA

200915596 48 year old female WAS HIT ON THE HAND BY A FALLING CEILING FAN. DX: RIGHT HAND FRACTURE.

210202899 30year old male WAS INSTALLING A CEILING FAN AND ACCIDENTALLY BEGAN TO COME DOWN LOST HIS BALANCE FALLING ON A BOX FRAME RESULTING IN LACERATION TO HIS HAND AND LACERATION TO RIGHT FOOT. DX: LACERATION RIGHT FOOT AND LACERATION RIGHT HAND

201020077 48year old male WAS PUTTING UP A CEILING FAN AT HOME WHEN HE WAS STRUCK IN THE WRIST WITH THE BLADE DX: CONTUSION TO WRIST

201108499 29year old male PATIENT HAVING RIGHT UPPER BACK PAIN SINCE A CEILING FAN FELL ON HIS RIGHT ARM TODAY DX: RIGHT UPPER BACK PAIN

201200650 37year old female PT STS CEILING FAN FELL FROM THE CEILING HITTING PT IN THE LEG. DX: LEG CONTUSION.

201200651 31year old male PT STS CEILING FANS FELL ON HIM WHILE IN BED HITT LEGS AND HIP. DX: LEG CONTUSION.

201234762 69year old female.WHILE SLEEPING CEILING FAN FELL ON FOREHEAD.DX.LAC.FOREHEAD

201110731 45year old male HAD A CEILING FAN FALL ONTO HIS HEAD FOUR WEEKS AGO CONTINUED HEADACHE DX: POST CONCUSSION SYNDROME

201231242 8year old male WAS AT HIS GRANDMA'S WHEN THE GLOBE FROM THE CELING FAN FELL AND PATIENT TRIED TO CATCH IT, CUTTING HIS RIGHT ARM. DX: LACERATION OF RIGHT FOREARM.

201251388 63year old female PRESENTS AFTER A FALL X2 WEEKS. PT STATES SHE WAS PUTTING UP A CEILING FAN WHEN SHE LOST HER BALANCE, FELL ONTO THE BED AND THEN ONTO HER BUTTOCKS ON THE CEMENT FLOOR. -HEAD STRIKE. DX: FALL, COCCYX CONTUSION

2019

2019

CPSC Case #

Narrative

190115444 4year old male WHO WAS AT HOME WHEN A CEILING FAN FELL FROM 8-1/2 TO 9 FEET HIGH. HE WAS BENDING OVER AT THE TIME, AND IT HIT HIM IN THE BACK. DX: LACERATION OF BACK.

190119288 5year old female EYE PAIN AND ABR NOSE, CEILING FAN FELL OFF CEILING & STRUCK FACE

190431484 25year old male C/O HEAD INJURY. PT WAS SITTING ON COUCH WHEN A CEILING FAN FELL & HIT HIM ON THE HEAD, -LOC.DX MINOR HEAD INJURY WITHOUT LOSS OF CONSCIOUSNESS.

190438414 31year old male WAS INSTALLING CEILING FAN WHEN IT FELL ON HEAD. -FALL -LOC +HEAD PAIN DX SCALP LAC

190442421 65year old female WAS SHOCKED BY A MALFUNCTIONING CEILING FAN SHOCK WENT THROUGH HER ARM AND THROUGH HER BACK ABOUT 6 FEET DX: ELECTRIC SHOCK INJURY

190504645 70year old male ON LADDER FIXING CEILING FAN WHEN HE FELL, 6-7 FT, LANDED ON SHOULDER COMPLAINS OF PAIN DX-CONTUSION RT SHOULDER, CONTUSION SCALP

190510351 3YR M PLAYING IN LIVING ROOM WHEN CEILING FAN FELL AND STRUCK HIM ON HEAD;DX SCALP LAC

190531689 30year old male HAD CEILING FAN FALL ONTO HEAD. NO LOC. DX: HEAD LACERATION

190534847 45YM MOVING FURNITURE HOME WHEN A FAN FELL FROM 4FT HEIGHT STRIKING HEAD W/O LOC YET H/A&NAUSEA SINCE, DX: CONCUSSION

190549199 5MO F CEILING FAN FELL, BOUNCED OFF THE WALL AND THE BED, BLADE HIT ABDOMEN;DX ABDOMINAL CONTUSION

190622032 9YR F SITTING AT HOME UNDER CEILING FAN, PIECE OF LIGHT FIXTURE FELL HITTING HER IN HAND;DX HAND LAC

190625745 18 year old male - A CEILING FAN FELL AND HIT PT ON THE FACE. DX LACERATION

190650411 60year old female CEILING FAN FELL ON HEAD, DX: INJ OF HEAD

190701002 A 46year old female STATES CEILING FAN FELL ON HEAD AT HOME, DX CONTUSION TO HEAD WITH HEMATOMA TO HEAD

190747973 12 year old female - FAN DROPPED ONTO PTS HEAD. DX HEAD INJURY

190804970 65year old male WAS STANDING ON HIS BED WORKING ON A CEILING FAN AND FELL ONTO THE FLOOR DX: CLOSED HEAD INJURY STRAINED NECK

190817677 23year old female PT REPORTS WAS SLEEPING AT A FRIED'S HOUSE WHEN A FAN FELL ON TOP OF HER DX: LAC RT EYEBROW

190840241 52 YO F STATES A BLADE FROM CEILING FAN FELL AND HIT HER ON TOP OF HEAD DX HEMATOMA SCALP

190857912 31 year old male WAS SLEEPING ON HIS STOMACH WHEN A CEILING FAN FELL ON HIS POSTERIOR SHOULDER, C/O SHOULDER PAIN, NO TRAUMATIC INJURY. DX: SHOULDER PAIN

190919502 35year old male PT STS A CEILING FAN DROPPED HITTING HIM ON RT HAND. DX: RT HAND LACERATION

190929754 39year old male HAD A WOODEN BLADE FROM A CEILING FAN FALL ONTO HEAD WHILE AT HIS GIRLFRIENDS HOUSE DX: CLOSED HEAD INJURY

190950625 42year old female PAIN IN NECK INSTALLING A CEILING FAN AT HOME. DX: NECK PAIN

190951511 40 year old male WITH NECK AND BACK PAIN AFTER THE CEILING FAN FELL AND HIT HIM IN THE BACK TONIGHT ABOUT 3 HOURS PRIOR TO ARRIVAL. PT STATES THAT HE WAS JUST LAYING IN THE BED AND IT HIT HIM. DX CERVICAL STRAIN, ACUTE THORACIC Myear old femaleASCIAL STRAIN

190962605 23 year old male HIT ON THE HEAD BY A CEILING FAN THAT FELL ON HIM ONE HOUR AGO, DX: HEAD INJURY

191000407 29year old female WAS AT HOME WITH A CEILING FAN FELL ONTO UPPER BACK AND HEAD DX: CONTUSION TO BACK CLOSED HEAD INJURY

191013492 45year old male WAS INSTALLING A CEILING FAN AND FELL OFF THE LADDER AT HOME DX: RIGHT LOWER LEG PAIN

191016376 59year old female ROLLED OUT OF BED AND HIT HEAD ON FANC/O NOT FEELING WELLDX PERSON
W/ FEARED COMPLAINT

191028710 6year old male A FAN AT SCHOOL FELL AND HIT PT IN HIS HEAD. DX CHI AND FOREHEAD
CONTUSION

191064043 55year old female C/O SHOULDER AND UPPER BACK HURTS SINCE CEILING FAN FELL ONTO HER. DX
SHOULDER AND UPPER BACK CONTUSION

191135383 56year old female FELL TAKING DOWN A CEILING FAN FELL OFF A STEP LADDER DX: FRACTURED
THORACIC VERTEBRA

191207804 34 year old male WITH LEFT NECK AND SHOULDER PAIN, PT REPORTS THAT A LARGE CRACK IN HIS
CEILING AROUND THE FAN FELL ON HIS LAST NIGHT, DX NECK PAIN LEFT SIDE, ACUTE PAIN OF LEFT
SHOULDER

191213587 29year old female WAS AT HOME WHEN A BLADE FROM A CEILING FAN FELL OFF ONTO FACE DX:
LACERATION TO FACE

200136653 50year old male.INSTALLING CEILING FAN FELL ON FACE.DX.LAC.RT.EYELID

200248853 43year old female TRIED TO TURN OFF CEILING FAN AND IT FELL ON HER HEAD. DX CLOSED HEAD
INJURY, CONCUSSION

200301513 67year old male.CEILING FAN FELL ON HEAD.DX.LAC.HEAD.

2018

2018

CPSC Case #

Narrative

180315431 89year old male EVAL OF R ANKLE, PT STS YESTERDAY MORNING @ 5AM CEILING FAN FELL OFF
FROM CEILING & HIT PT IN R ANKLE WHILE HE SLEPT DX R ANKLE PAIN

180349162 17 year old female CEILING FAN FELL ONT HEAD & SHOULDERS 1 WK AGO. HAS INCREASINGNECK
PAIN. DX NECK CONTUSION; SHOULDER CONTUSION

180440320 64year old male WAS PUTTING UP CEILING FANS IN HIS HOUSE YESTERDAY AND NOW HAS PAIN IN RIGHT SHOULDER DX SHOULDER PAIN

180537938 62year old male HAD A CEILING FAN FALL OUT OF THE CEILING ONTO THE DINING ROOM TABLE AND SHATTER PIECE OF GLASS WENT INTO LOWER LEG LACERATION LOWER LEG

180538758 49year old male-SCALP LAC-30# FAN PART FELL ON PT'S HEAD-LOCATION NS NASAL BONE OPEN FX.

180564056 74 year old female WAS HIT BY A CEILING FAN THAT FELL OUT FROM THE CEILING.

180614243 47 YO MALE HAD A CELING FAN FALL AND HIT HEAD. DX CLOSED HEAD INJURY

180624873 26 year old female CEILING FAN FELL FROM CEILING AND HIT PT DX: FACE LAC

180734576 32 year old male WAS HIT N HEAD BY A CEILING FALN 30 MIN AGO. C/O PAIN IN FOREHEAD. DX MIILD CONCUSSION

180736744 9 year old female GLOBE ON CEILING FAN FELL BROKE LACERATED PTS LOWER LEG

180745122 32year old male PT STS HE WAS WORKING ON A FAN WHEN IT FELL HITTING LEG. DX: RIGHT ARM LACERATION.

180825547 69 YR OLD FEMALE HAD A FAN FALL ONTO HER LEG WITH SKIN TEAR TO LOWER LEG

180831642 14year old female WAS HIT IN THE HEAD BY BEDROOM CEILING FAN, NO LOC, CEILING FAN BLADE FELL AND HIT HIM IN THE HEAD, DX BLUNT HEAD INJURY;

180856312 A 3year old male WAS SITTING AT TABLE, CEILING FAN FELL ON HEAD, CONTUSION TO HEAD

181027614 11 YO M PT PLAYING IN HIS ROOM WHEN THE CEILING FAN FELL OFF THE CEILING LANDED ON PT CUTTING RT UPPER ARM DX 2CM LAC RT HUMERUS

181029186 16 year old male INJURED HEAD,WHILE IN BED,CEILING FAN FELL ON HIM,AT HOME, 2 WEEKS AGO. DX-CLOSED HEAD INJURY,CONCUSSION

181035707 47 year old female PT WAS STANDING ON A BED INSTALLING A CEILING FAN & LOST BALANCE& FELL OFF LANDING ON SHOULDER DX RIGHT SHOULDER PAIN

181039139 20YM RTS A FAN FELL ONTO HIS HEAD WHILE SLEEPING 1WA>>CHI
181246223 28year old male INTALLING A CEILING FAN AND IT FELL HITTING HEAD. / SCALP LAC
181249230 27year old female PAIN IN SHOULDER WHEN CEILING FAN FELL ONTO PATIENT AT HOME. DX: RT
SHOULDER PAIN

2017

2017

CPSC Case #

Narrative

170125189 LT SHOULDER STR. 25year old male CEILING FAN FELL ON SHOULDER AT HOME.

170332472 HIP CONT. 52year old female BEDROOM CEILING FAN FELL ONTO PATIENT WHILE SLEEPING AT HOME.

170332473 CHI. 45year old female BEDROOM CEILING FAN FELL ONTO HEAD WHILE SLEEPING AT HOME.

170339774 28YF RTS THE LANDLORD CHANGED CEILING FAN THAT CONTAINED GLASS LIGHT WHICH FELL ON TOP OF HER HEAD&IT SHATTERED C/O H/A&LHD'NESS>>CONCUSSION

170538937 19 MO FEMALE INJURED HEAD, CEILING FAN FELL ON HEAD. DX-CONTUSION SCALP

170543168 39 year old male UPPER BACK CONTUSION, CEILING FAN FELL HITTING HIS BACK

170544041 CLOSED HEAD INJURY 27year old female FAN FELL ONTO HEADDX: CHI

170553902 4year old female LAC HEAD- CEILING FAN FELL ON HEAD

170569130 15year old female NS INJ FACE- CEILING FAN FELL ON PT

170739878 60year old male ARRIVES C/O SHOULDER PAIN, PUTTING UP CEILING FAN, FELL DOWN 4FEET, HURT SHOULDER DX-CONTUSION RT SHOULDER FALL

170740295 11year old male-PT TRYING TO FIX CEILING FAN WHEN THE GLASS PORTION FELL ONTOFACE IMMEDIATE BLEEDING. DX- 7.5CM FOREHEAD LACERATION.

170832679 46 year old male HEAD & NECK PAIN AFTER HAVING A CEILING FAN FALL ON HEAD TODAYAT HOME. DX CERVICAL STRAIN, CLOSED HEAD INJURY

170834181 A 16year old male STATES CEILING FAN FELL AND GLASS LITE COVER BROKE, LAC TO HAND

170851999 22 year old female INJURED HEAD, CEILING FAN FELL ON HEAD WHILE IN BED AT HOME. DX-
CLOSED HEAD INJURY

170853779 47year old female LAC FACE- MAKING BED, CEILING FAN FELL ON PT

170872595 62year old female REPORTS CEILING FAN FELL ON RT SIDE OF FACE. DX: RT EYE AND FACEPAIN.*

170916472 5month old male month old male SMELLED ELECTRICAL SMOKE COMING FROM PTS BEDROOM
THE CEILING FAN WAS SMOKING ROOM FILLED WITH SMOKE- TO ED FOR POSSIBLE SMOKE
INHALAT

170954722 12year old male WAS LYING ON HIS STOMACH ON BED WHEN A CEILING FAN FELL HITTING PT IN
BACK OF HEAD DX: HEAD LACERATION

171011622 63year old female HAD A SECTION OF A CEILING FAN FALL ONTO HEAD AT HOME CLOSED
HEADINJURY

171030985 14 year old female - CEILING FAN FELL ON PT. DX WRIST CONTUSION

171041926 61 year old male C/O HEAD & NECK PAIN AFTER CEILING FAN FELL ON HIM THIS AM.DX
CONCUSSION, CERVICAL STRAIN, CONTRUSION OF LT SHOULDER

171104924 36 year old female C/O DIZZINESS, LIGHTHEADEDNESS AND HEADACHE SINCE A FAN FELL STRILING
HER HEAD 5 DAYS AGO. DX CLOSED HEAD INJURY

171218478 CT,COCCYX.71year old female.WHILE WALKING GOT TANGLE WITHF CABLE OF FAN FALLING DOWN
ON FLOOR

2016

2016

CPSC Case #

Narrative

160112322 17year old female WAS SITTING AT HOME AND A GLOBE FROM A CEILING FAN FELL AND HIT PTIN
HEAD. HEAD INJURY*

160201019 47year old female SAW CEILING FAN FALLING AND PUT HAND UP TO BLOCK IT DX SPRAIN WRIST

160213484 61year old male STANDING ON A STOOL HANGING A CEILING FAN AND FELL OFF LACERATION TO
FACE

160360022 40year old female AT HOME STS CEILING FAN FELL ON PTS HEAD SAW SPOTS WHEN IT HIT NLOC
DX NECK STRAIN HEADACHE

160402495 40 year old female CEILING FAN FELL ON PT AT HOME DX; FOREHEAD LAC

160420785 15year old female CEILING FAN FELL ON HER; DX CHI, LAC FOREHEAD

160446536 42 YO F WAS TRYING TO REPAIR A CEILING FAN WHEN IT FELL ONTO HER HEAD/FACE AND ARM DX
HEAD INJ/LAC

160543849 25 YR OLD MALE HAD CEILING FAN CATCH FIRE AND PULLED IT DOWN BURNING HANDS, UNK IF
FIRE DEPT ATTEND

160550759 16 year old male HAD CEILING FAN FALL ONTO KNEEDX CONTUSION

160614263 55 year old female - CONCUSSION - CEILING FAN FELL AND HIT PT IN HEAD

160653230 12year old female HAD A PIECE OF A CEILING FAN FALL ONTO HEAD AT HOME CLOSED HEAD
INJURY

160653844 31year old male WITH HEAD INJURY AFTER A FAN FELL ON PT DX HEAD INJURY*

160704286 2 YO F PER month old male SHE WAS IN KITCHEN HEARD LOUD NOISE SAW THAT A LARGE FAN HAD
FALLEN ON THE PT AND CUT HER DX LT CHEEK LAC

160710135 9 year old male - A BLADE OF A CEILING FAN FELL AND HIT PTS HEAD. DX HEAD INJURY

160728421 CEILING FAN FELL ON PT'S HEAD. HEAD CONTUSION. 45 year old female*

160733450 2 month old female - FAN FELL ON PTS HEAD. DX HEAD INJURY

160812800 16month old female-PT WAS HOME WHEN LIGHT /CELING FAN FELL ONTO FOREHEAD NO LOC N/V.
LACERATION TO FOREHEAD. DX- 2CM FOREHEAD LACERATION.

160821384 4year old male LAC HEAD- GLASS LIGHT GLOBE FIXTURE FELL FROM CEILING FAN ONTO PT

160849617 28 YO M TRAUMA ALERT S/P CEILING FAN FELL ON HIS HEAD SHOULDER LOC DX FOREHEAD RT SHOULDER ABRASIONS

160853324 26year old male REPORTS THAT CEILING FAN FELL AND HIT HIM ON HEAD. HAS HEAD PAINNOW. LWOT. *

160857622 26 year old female DX LACERATION TO FOREHEAD - DUE TO FALLING CEILING FAN TODAY.

160942759 21 year old female WAS SITTING IN HER KITCHEN WHEN A CELING FAN FELL AND STRUCK HERHEAD C/O HEAD AND NECK PAIN DX CERVICAL STRAIN

160943402 70year old female HANGING A CEILING FAN AND FELL OFF THE LADDER AND SUSTAINED A CLAVICLE FX

161001944 LAC.HEAD.57year old female.REFERS A CEILING FAN FELL ON HEAD WHILE IN BED.

161005808 40 year old male DX SCALP LACERATION - S/P PT STOOD ON WASHING MACHINE INLAUNDROMAT WHEN CEILING FAN HIT HEAD.

161014365 44 year old male WAS HANGING A CELING FAN AT HOME AND FELL OFF LADDER LANDING ONLT SHOULDER. DX SHOULDER DISLOCATION @

161117756 4year old female HIT HEAD ON CEILING FAN; DX LAC FOREHEAD

161132359 46 year old female. SITTING IN HER SON'S CLASSROOM & THE CEILING FAN FELL ON PT FACE,LAC & NOSE SWELLING. DX: CLOSED FX OF NASAL BONE

170100833 55 year old female REPORTS CEILING FAN FELL ON HEAD & LATER SHE FELL DOWN SOME STAIRS & "PEOPLE" FELL ON TOP OF HER, CAUSING HEAD PAIN. DX HEAD INJURY/

2015

2015

CPSC Case #

Narrative

150140897 58 year old male NECK, SHOULDER, BACK PAIN. YESTERDAY PUT UP CEILING FAN. HAD ARMS ABOVE HEAD AND NECK BENT MOST OF DAY. DX: MUSCLE SPASM

150238105 21year old female-FACIAL AB-CUT WHEN A CEILING FAN FELL FROM CEILING-@ HOME

150432012 48 year old female CEILING FAN FELL, HIT PT, KNOCKED HER OUT OF CHAIR DX: NECK CONTUSION
150600442 72year old male TRYING TO HANG A CEILING FAN AT HOME AND SUSTAINED A FOREARM
LACERATION
150604880 33 year old female CEILING FAN FELL, HIT PT IN FACE DX; OPEN NOSE FX
150607319 PT STUCK HAND IN FAN. LACERATION HAND, RIGHT, COMPLICATED. 21 month old female*
150609233 R EYEBROW LAC/27YOWM AT HOME WAS ATTEMPTING TO INSTALL A CEILING FAN AND THE
BLADE OF THE FAN STRUCK HIM CAUSING LACERATION.
150614890 54year old male WITH 2ND AND 1ST DEGREE BURNS TO UPPER BODY AFTER CEILING FAN STARTED
A FIRE AND WALLS IN HOME WERE BURNING. FIRE DEPARTMENT RESPONDED.
150640946 11year old female-PT HAD A LARGE FAN THAT FELL FROM HEIGHT 10-12 FEET HITTING PT TO THE
HEAD. DX- CHI.
150658269 24 year old female WAS CLEANING CEILING FAN AT HOME WHEN IT FELL ONTO HERSHOULDER DX
CONTUSION
150662048 PT WAS WORKING ON A CEILING FAN AND FELT A PULL. LOW BACK PAIN.43 year old male*
150728242 49year old female LAC F'HD- FAN FELL FROM CEILING
150728355 81year old male LAC TO UPPER LIP WHEN CEILING FAN FELL HITTING PT IN FACE. DX LIPLAC
150728875 13 year old male WAS EATING AND CEILING FAN BLADE FELL AND HIT HIS HEADDX CONCUSSION
150803450 HAND ABR 9year old male MOVING FAN FELL INTO GLASS AT HOMEDX: ABR HAND
150822901 79year old female LAC HEAD- LIGHT FIXTURE FELL FROM CEILING FAN
150822955 28year old male STR NECK- INSTALLING CEILING FAN, FELL 4' FROM LADDER
150822988 36year old male FX RIBS- INSTALLING CEILING FAN, FELL ON TABLE
150847403 59YM UP ON A LADDER TRYING TO HANG A FAN WHEN FELL OFF STRIKING HEAD ONTO PIECE OF
WOOD NO LOC->CHI/LAC
150860118 41YM RTS A FAN FELL OFF THE CEILING HITTING HIS HEAD->LAC

150860338 22YM WAS CHANGING CEILING FAN, FORGOT TO TURN OFF POWER, GRABBED A WIRE&FELT A SHOCK C/O HAND N&T/HA>>ELECTRIC SHOCK

150921508 37 year old male LAC TO HEAD WHEN CEILING FAN FELL FROM THE CEILING AND HIT HIM

150924235 60year old male WSHOULDER & HAND PAIN 2/2 FAN THAT FELL FROM CEILING HIT HIS SHOULDER & THEN HE FELL ON HIS SHOULDER.

151007421 76year old male STANDING ON A STEP LADDER TAKING DOWN CEILING FAN. FAN FELL AND PT FELL ON TOP OF IT CUTTING EAR. / EAR LAC

151055928 80year old female AT THE FLEA MARKET WHEN A PIECE OF THE CEILING FAN CAME DOWN ONTOHEAD LACERATION TO SCALP

151058126 63year old female AT HOME WHEN CEILING FAN WITH LIGHT FIXTURE FELL ON HEADDX HEAD INJURY, HEAD PAIN, ABRASION

151143412 48year old female STATES A LIGHT FIXTURE FROM CEILING FAN FELL & HIT TOP OF HEAD. DX; HEAD INJURY

151219137 LAC.LT.EAR.57year old female.CEILING FAN FELL HITTING EAR

151226435 FRAC LOW TRUNK 56year old male PUTTING UP FAN FELL OFF LADDER AT HOMEDX: FRAC HIP

151230025 10 year old male WAS AT COUSIN'S HOUSE & WAS LAYING IN THE LIVING ROOM WHEN THECEILING FAN LIGHT COVER FELL OFF & HIT HIM IN HEAD- VOMITED. DX; CHI

151243534 56year old female CONT HEAD - CEILING FAN FELL FROM CEILING

151243823 82YF SENT IN FROM ECF C/O H/A P GOT HIT BY FALLING LIGHT FIXTURE FROM THE FAN TO HEAD NO LOC>>CHI

151247421 12year old male AT HOME STS CEILING FAN FELL OFF BRACKET & HIT PT ON R SIDE OF HEAD DX HEAD INJURY

160222186 49year old male RAN INTO BURNING HOME TO SAVE PEOPLE AND THE CEILING COLLAPSED AND A CEILING FAN FELL ON HIM. +LOC. DX SMOKE INHALATION, ?FD ON SCENE.

2014

2014

CPSC Case #

Narrative

140309768 26year old male CHANGING A CIELING FAN AND FELL 8 FEET OFF A LADDER ONTO HEAD SKULL FX
140404086 37year old male WITH CHI FROM A FALLING FAN
140431646 73YO M WAS ON LADDER WORKING ON CEILING FAN WHEN FELL OFF LADDER. DX:SUBARACHNOID
HEMORRHAGE. ADMIT.
140455467 32year old male FELL OFF LADDER WHILE PUTTING UP CEILING FAN AT HOME CHEST CONTUSION
140459978 24year old female WITH FOREHEAD LAC 2/2 CEILING FAN FALLING ON HER TODAY. NO LOC.
140522693 59 YO M, C/O LT NECK, SHOULDER PAIN S/P CEILING FAN FALLING ONTO LT SHOULDER, DX LT
SHOULDER PAIN
140532910 67year old female SITTING IN A RESTAURANT WHEN A PIECE OF A CEILING FAN FELL ONTO EHAD
CLOSED HEAD INJURY
140533352 87year old male FELL & A FAN FELL ONTO CHEST C/O RIB PAIN DX: RIBS CONTUSION
140605800 LT CORNEA ABRASION. 82year old female GLOBE FROM CEILING FAN FELL OUT AND SCRATCHED
EYE.
140606131 A 10year old female STATES CEILING FAN FELL ON HEAD, DX HEAD INJURY
140621518 5year old female PT COMPLAINING OF FOREHEAD CONTUSION AFTER A CEILING FAN FELL ONPT'S
FOREHEAD AT HOME DX CONTUSION#
140662507 59YM FROM GROUP HOME AFTER CEILING FAN FELL STRIKING HIS BACK, PT DENIES PAIN>>MED
EVAL
140667358 70 YR OLD MALE TAKING DOWN A FAN AND EXTENDED NECK STRAINING IT
140703104 DX SCALP CONTUSION 38year old female FAN FELL ON TOP OF PATIENT'S HEAD DIZZY/NAUSEA
140712492 88 year old female DISTAL RADIUS FX. PT WAS AT HOME WHEN HER CEILING FAN FELL HITTING
HER WRIST, SPLINT APPLIED F/U ORTHO

140801604 7 year old male MOTHER STATES A BLADE FROM CEILING FAN FELL OFF A FEW DAYS AGO IT WAS LEANING AGAINST WALL PT FELL LANDED ON BLADE DX LACERATION HAND

140835976 68YR OLD MALE PUTTING UP A CEILING FAN AND STRAINED NECK WITH SPASM

140907489 62 YM INJURED TOE WHEN A CEILING FAN FELL ON LEFT FOOT. DX TOE LAC

140967705 46year old male LAC HAND WHILE INSTALLING CEILING FAN

141011313 19 year old female LAC TO FACE WHEN STRUCK BY A CEILING FAN

141104132 64year old male HAD A CEILING FAN FALL ON HEAD, CONCUSSION, AND SCALP CONTUSION

141217642 21 year old female LAC TO HEAD WHEN CEILING FAN FELL AND HIT HEAD

150216298 69year old female HAD A FAN FALL ONTO HEAD LACERATION TO SCALP

2013

2013

Narrative

CPSC Case #

130159875 57 year old male DEVELOPED PAIN TO NECK & SHOULDER S/P HANGING A CEILING FAN ON THE CEILING LAST WEEK.*

130339950 54 year old female SUSTAINED A LACERATION OF THE SCALP FROM BEING STRUCK BY A FALLING FAN ABOUT THE WORKSHOP DOOR.

130348393 10month old female HAD CEILING FAN FALL ONTO HEAD AT HOMECLOSED HEAD INJURY

130441724 57YM REPORTS A CEILING FAN FELL ON TOP OF HIS HEAD NO LOC>>CHI/LAC

130508409 47 YO M WITH LOW BACK PAIN WHICH BEGAN WHILE HANGING CEILING FANS ON CEILING AT HOME. DX:LOW BACK MUSCLE STRAIN.

130633247 54year old male LOOKING UP AT A CIELING FAN THAT WAS WABBLBY AND FELL ONTO FACE LACERATION FACE

130713056 53year old female GOT HIT BY FALLING FAN DX: CONTUSION TO SHOULDER

130716773 24 YO M, C/O CEILING FAN FALLING ON HIS HEAD WHILE HE WAS REMOVING IT FRMO CEILING,FELL OFF LADDER (5 FT), NO LOC, DX SCALP LACERATION

130743728 67year old female HANDING CEILING FAN TO FRIEND ON LADDER;FRIEND FELL ONTO PTLAC LT
ELBOW DX: LAC/CONTUS ELBOW

130743737 78year old male INSTALLING FAN, FELL OFF LADDER;LANDED ON FRIEND; C/O LOW BACKPAIN DX:
BACK CONTUSOIN

130751372 47year old female WITH HEAD INJ 2/2 HER CEILING FAN FALLING AND HITTING HER IN THEHEAD.
NO LOC. REPORTS DIZZINESS & SEEING SPOTS.

130842821 47year old male WITH CHI FROM A FALLING FAN

130844229 37 year old female WAS AT A PARTY AT A PUBLIC FACILITY AND A CEILING FAN FELL ONTOHER
HEAD, DX: CHI

130901274 43 YO M, S/P ACCIDENT W/ CEILING FAN FALLING ON HIS HEAD YESTERDAY AT 8PM, HAD
BLEEDING INITIALLY, DX SCALP LACERATION

130917238 57 year old female C/O FAN FALLING AND STRIKING HER IN HEAD. DX FOREHEAD LAC

130938185 PAIN UP TRUNK 82year old female CEILING FAN IN HOUSE FELL STARTLING HER AT HOMEDX:
CHEST PAIN

130945163 37 year old female STATES A CEILING FAN FELL ON HER TOEDX:FRACTURE TOE

131129265 22year old male-CONCUSSION-A FAN MOTOR FELL HITTING PT'S HEAD-@ HOME

131221372 15year old male WITH THUMB LACERATION AFTER TRYING TO CATCH FALLING FAN DX
THUMBLACERATION **

140101020 33 Year old female WAS AT HOME AND THE CEILING FAN FELL ON HER. DX LOW BACK PAIN

Relevant Incidents involving Ceiling (Paddle)

Fans 2022-2013

Public Input 2484

This report contains the narrative reports of incidents involving injuries from ceiling (paddle) fans. These reports come from the National Electronic Injury Surveillance System (NEISS), which is maintained by the Consumer Product Safety Commission. According to the NEISS Coding Manual, “The primary purpose of NEISS is to provide timely data on unintentional consumer product-related injuries and deaths occurring in the U.S. NEISS injury data are gathered from the emergency departments (ED) of 96 hospitals selected as a probability sample of all U.S. hospitals with 24-hour EDs and at least 6 inpatient beds. Each participating NEISS hospital is hand-selected by CPSC

because it provides an important representation of all other hospitals of its size and unique characteristics in the U.S.”(January 2022, P.1) It is important to note that at the end of 2021, there were 6,129 hospitals in the US (<https://www.statista.com/statistics/185843/number-of-all-hospitals-in-the-us/#:~:text=This%20statistic%20shows%20the%20number,2021%2C%20there%20were%206%2C129%20hospitals>). In addition, there are approximately “10,800 active urgent care clinics in the US” (<https://www.definitivehc.com/resources/healthcare-insights/urgent-care-clinics-us#:~:text=According%20to%20data%20from%20Definitive,urgent%20care%20clinics%20per%20capita.>). This strongly indicates that the number of injuries is much higher.

The primary goal of admitting personnel is to collect the necessary information to begin treatment. It is important to understand that some incidents may simply be classified as falls, without a relation to a consumer product because the additional detail may not be considered clinically important. In fact, the data collected by CPSC focuses primarily on injuries caused by consumer products. Therefore, falls may not appear with complete details in these statistics. A few of the incidents that are included in this report involve pieces of fans falling on occupants. Such incidents likely occurred because the installation was not as robust as it needed to be, allowing parts to loosen and fall.

This report does not include workplace injuries. Workplace injury data is collected by the National Institute of Occupational Safety and Health.

There are a number of incidents involving injuries to occupants of bunk beds. There are also incidents involving injuries to children who threw some object at a fan. Such incidents are excluded from this report, because they are not germane to this public input.

Relevant Incidents involving Ceiling (Paddle) Fans 2022-2013

2022

2022

CPSC Case

Narrative

220419511 25year old male PRESENTS WITH EVALUATION AFTER HEAD INJURY. PATIENT STATES HE WAS STANDING NEAR A DOOR WHEN SUDDENLY PART OF THE CEILING FELL AND CEILING FAN STRUCK HIM IN THE TOP OF HIS HEAD CAUSING HIM TO FALL BACKWARDS. DX: STRAIN OF MUSCLE,FASCIA AND TENDON AT NECK LEVEL. SPRAIN OF INTERPHALANGEAL JOINT OF UNSPECIFIED FINGER.

220348929 41 year old male REPORTS A FAN FELL AND STRUCK HIM IN THE THUMB.DX: LACERATION OF LEFT HAND

220361987 27 year old male ELECTROCUTED AT HOME WHILE TRYING TO INSTALL A CEILING FAN, TRIED TO TURN ON WHILE THE OTHER HAND WAS TOUCHING DISHWASHER. DX ELECTROCUTION ACCIDENT, CHEST STRAIN

220547269 64year old male C/O FOREIGN BODY. PT WAS SLEEPING & CEILING FAN FELL DOWN ONTO HIM.

THE BULB BROKE OVER HIS LEG. DX: MULTIPLE ABRASIONS, LLE LAC, KNEE CONTUSION

220567703 69year old female, TO ER AFTERFALL AT HOME, PT REACHING FOR FAN & FELL HITTING HEAD ON FLOOR, PT SUSTAINED LACERATION OF CHIN, & SKIN TEAR TO BILAT FOREARMS PT HAS BUMP ON BACK OF HEAD, NO LOC, PT IS ON ***, PT HAS SOME NAUSEA, FALL OCCURED 1 HR AGO, NO DIZZINES & WAS ABLE TO GET SELF UP HERSELF DX FALL, CHIN LACERATION, SKIN TEAR TO BILATERAL FOREARMS

220571365 69 year old female STATES THAT A CEILING FAN FELL ON HER IN FEBRUARY 2022, AND HAS SINCE BEEN EXPERIENCING DIZZINESS AND FEELINGS OF BEING OFF-BALANCE. DX CHRONIC CONFUSION, CHRONIC BALANCE PROBLEM, CHRONIC VISUAL DISTURBANCE

220600649 52year old female HAD A CEILING FAN FALL ONTOP OF RIGHT FOOT DX: CONTUSION TO FOOT

220616691 59year old female, UP ON A TABLE TRYING TO FIX CEILING FAN WHEN FELT DIZZY, STEPPING DOWN ON A CHAIR WHICH BROKE UNDERNEATH HER WEIGHT AND FELL, +ECCHYMOSSIS TO THIGH
DX: FALL, INTIAL ENCOUNTER; NEARSYNCOPE; LEFT WRIST PAIN; LEFT LEG PAIN

220727044 46year old female PRESENTS AFTER A CEILING FAN FELL ON HER HEAD WHILE SHE WAS AT A LAUNDROMAT. SHE HAS LACERATION TO HER RIGHT FOREHEAD. DX: FOREHEAD LACERATION

220868992 55 year old female WAS HIT ON THE KNEE BY A FALLING FAN. DX: LEFT KNEE CONTUSION.

220900699 32year old female PT REACHED UP TO STABILIZE A BROKEN FAN WHEN SHE WAS ELECTRICAL SHOCK TO HAND. DX: ACUTE RIGHT HAND ELECTRICAL INJURY.

220961902 47year old male PT WAS AT HOME UP ON A LADDER HANGING CEILING FAN LOST BALANCE FALLING HITTING LEFT HEAD ON CEMENT. DX: FALL, HEAD INJURY.

220751022 47year old female HAD A CEILING FAN FALL ON HEAD. DX SHOULDER PAIN, NECK PAIN

220949006 34year old female PT HAD THE CEILING FAN FALL ONTO HER RT LOWER LEG AND FOOT HURT TOE PAINFUL DX FRACTURE RT GREAT TOE, CONTUSION RT LOWER LEG

220822776 38year old female, STANDING ON A LADDER HELPING BOYFRIEND PUTTING A FAN WHEN FELL DX: RIGHT WRIST SPRAIN

220839695 31year old male,A CEILING FAN FELL OFF THE CEILING AN HIT HIM ON BACK,DX:LAC BACK

220867719 47year old male, STANDING ON THE BED TRYING TO HOOK A CEILING FAN AND FELL OFF AGAINST A CHAIR DX: HEMATOMA OF BUTTOCK

220925332 58year old male WAS HIT IN THE HEAD BY A FALLING PIECE OF A CEILING FAN. DX: HEAD TRAUMA, CONCUSSION

220926009 9month old male STRUCK BY GLASS LIGHT FIXTURE GLOBE THAT FELL OFF CEILING FAN. DX: HEAD INJURY, FACIAL LAC

220960075 57 year old male WAS CHANGING OUT A FAN, DROPPED IT AND CUT HIS R HAND 5TH DIGIT, "TO THE BONE." DX: LEFT WITHOUT BEING SEEN

221007001 18 month old male - PART OF CEILING FAN FELL AND HIT PT ON THE HEAD. DX HEAD INJURY

221014739 25year old female HAD A CEILING FAN FALL HITTING HER IN THE HEAD. DX: CLOSED HEAD INJURY, NECK PAIN

221020990 25year old female HAD A CEILING FAN FALL HITTING HER NECK, DX: CONTUSION NECK

221021003 52year old male HAD A CEILING FAN FALL NEAR HIM AND A PIECE BROKE OFF AND HIT HIM IN THE RT EYE. DX: TRAUMATIC IRITIS

230200510 35year old female STS A CEILING FAN FELL ON HEAD AT LAUNDRY MAT C/O NECK PAINDX ACUTE TORTICOLLIS

221007169 83year old female WITH INJURY TO HEAD, HER HUSBAND WAS STANDING ON THE BED WORKING ON A FAN, HE FELL AND HIT PATIENT'S HEAD WITH HIS HEAD.DX: CONTUSION WITH SOFT TISSUE HEMATOMA SCALP.

221007170 80year old male WITH FALL AT HOME, STANDING ON BED WORKING ON A CEILING FAN, FELL OFF BED AND HIT FLOORDX: LAC. SCALP; SOFT TISSUE HEMATOMA SCALP

221029830 8year old female PIECE OF CEILING FAN BROKE & FELL ON PT. DX: ABR FACE

221168661 71year old female WAS SITTING IN HER WHEELCHAIR AT HOME WHEN CEILING COLLAPSED AND CEILING FAN LANDED ON PT. DX:CLOSED COMPRESSION FX L4 AND WEDGE COMPRESSION FX, L3, ACUTE NECK AND BACK PAIN.

221227240 2year old male PRESENTS AFTER A CEILING FAN FELL BESIDE HIM, CAUSING MULTIPLE LACERATIONS TO HIS RIGHT FOREARM. DX: LACERATION OF MULTIPLE SITES OF RIGHT UPPER EXTREMITY

221210342 74 year old male CEILING FAN FELL ON HEAD DX; SCALP LAC

2021

2021

CPSC Case #

Narrative

210123158 23year old female HAD A CEILING FAN FALL ONTO HER HEAD AT HOME DX: CLOSED HEAD INJURY;
LACERATION SCALP

210127852 48 year old male INJURED HAND,FELL OFF LADDER,CHANGING CEILING FAN,AT HOME. DX-
CONTUSION LEFT HAND

210147668 41year old male ELECTRICAL INJURY TO HAND WHILE CHANGING A CEILING FAN AT HOME. DX:
LOW VOLTAGE ELECTRIC SHOCK HAND, LEFT HAND PARASTHESIA.

210148674 13 year old female AT HOME WHEN A CEILING FAN FELL ONTOP OF HER C/O SHOULDER PAIN DX
SHOULDER INJURY

210202412 53 year old female INJURED HEAD,NECK,CEILING FAN FELL ON HEAD WHILE PATIENT WAS LAYING
IN BED,AT HOME. DX-TRAUMATIC HEAD INJURY,INJURY NECK

210211645 68year old male WAS WORKING ON A CEILING FAN AND FELL OFF THE LADDER DX: SPLEEN
FRACTURE

210222909 8month old male JHAD A SECTION OF THE CEILING FAN FALL ONTO FACE WHILE SLEEPING IN
month old males BED DX: LACERATION TO FACE

210232864 39year old male WAS HANGING A CEILING FAN AT HOME AND IT FELL ONTO HEAD DX: CLOSED
HEAD INJURY LACERATION TO SCALP

210233092 44year old female WAS AT HOME WHEN A FAN CAUGHT ON FIRE SHE INHALED THE SMOKE AND
DEVELOPED COUGHING NO COHGB DRAN NS IF FD ON SCENE DX: SMOKE INHALATION

210303893 73 year old male FIXING CEILING FAN AND FELL FROM LADDER HIT HEAD ON NIGHTSTAND DX CHI

210307324 88year old male WAS TRYING TO HANG A CEILING FAN ON THE CEILING AND DEVELOPED PAIN IN
RIGHT SHOULDER DX: RIGHT SHOULDER STRAIN

210342628 9year old male CEILING FAN FELL ONTO PT; DX: CHI, SCALP LAC

210343317 59 year old female HIT HEAD ON CEILING FAN AT HOME IN KITCHEN DX SCALP LACERATION

210350387 48year old male PT HANGING UP A CEILING FAN, FELT POPPING/SNAPPING SENSATION IN RT SHOULDER DX: ACUTE SHOULDER PAIN #

210357241 34year old female WAS ON A LADDER HANGING A CEILING FAN ON THE CEILING AND IT FELL AND LACERATED HER LEFT EYEBROW DX: FACIAL LACERATION

210416920 30year old male WAS SITTING O HIS COUCH WHEN A CEILING FAN FELL ONTO HIS HEAD DX: CLOSED HEAD INJURY

210417621 45 year old male STANDING ON LADDER TO INSTALL CEILING FAN, HURT BACK. DX LS STRAIN

210448460 47year old female HAD A CEILING FAN FROM HER KITCHEN FALL ON HER HEAD DX: CLOSED HEAD INJURY

210507955 57year old female CEILING FAN FELL ONTO RIGHT HAND DX: LACERATION TO HAND

210511950 53year old male WHILE PUTTING FAN UP,FELL OFF LADDER--DX:FX SHOULDER+RIB

210534932 21 year old male WAS STANDING ON A BED PUTTING UP A CELING FAN WHEN HE FELL OFF OF THE BED LANDING ON OUTSTRETCHED RIGHT ARM. DX: RIGHT SHOULDER PAIN S/P FALL, SUSPECTED ROTATOR CUFF INJURY

210538106 37year old male HAD A CEILING FAN FALL ONTO HEAD. DX: CHI

210616701 29 year old male. PT C/O OF FOREHEAD PAIN AFTER CEILING FAN FELL FROM CEILING AT HOME. DX: SCALP CONTUSION

210616702 10 year old male. PT C/O HEAD PAIN AFTER CEILING FAN FELL FROM CEILING AT HOME. DX: SCALP CONTUSION

210631134 40year old male WAS HANGING A CEILING FAN AND IT FELL ONTO FACE DX: NASAL FRACTURE

210638703 44 year old male WAS INSTALLING A CEILING FAN AND HAD IT RESTING ON TOP OF A LADDER; IT FELL OFF THE LADDER STRIKING HIM ON THE HEAD +HEADACHE DX CHI, SCALP HEMATOMA, SUPERFICIAL LAC

210715623 62 year old male. HEAD INJURY AFTER A CEILIGN FAN FELL & HIT HIM ON THE TOP OF THE HEAD.

DX: CLOSED HEAD INJURY; SCALP LAC

210721503 64year old female, A CEILING FAN, FELL OFF THE CEILING STRIKING HEAD WITHOUT LOSS OF CONSCIOUS, DX: LACERATION OF SCALP; MINOR HEAD INJURY

210741839 32year old female WAS WALKING TO HER ROOM WHEN THE CEILING AND CEILING FAN COLLAPSED ONTO HER HEAD DX: NECK PAIN

210844629 45year old female WAS IN AN APARTMENT FIRE WHEN AN ELECTRICAL FAN CAUGHT FIRE INHALED THE SOKE AND STARETD TO COUCH AND WHEEZE COHGB OF 3 FD WAS ON SCENE DX: SMOKE INHALATION

210847909 31 year old female CEILING FAN FELL ON HEAD DX: SCALP CONTUSION

210865407 44year old female HAD A CEILING FAN FALL ONTO HEAD DX: CONCUSSION

210926430 10year old female HAD A CEILING FAN FALL ONTO HER NOSE. DX: NOSE SWELLING; LWBS

211052894 88 year old male HAD A CEILING FAN FALL AND HIT HIM ON THE HEAD. DX: CLOSED HEAD INJURY.

211066278 52year old male PATIENT PUTTING UP A CEILING FAN ON 6 FOOT LADDER AND LOST BALANCE FALLING HAVING LEFT RIB PAIN, LEFT ELBOW EFFUSION DX: RIB FRACTURE, ELBOW INJURY, ACCIDENTAL FALL FROM LADDER

211200580 21year old male PT WAS AT HOME WHEN A CEILING FAN FELL HITTING SHOULDER. DX: SHOULDER PAIN.

2020

2020

CPSC Case #

Narrative

200105581 48year old male WITH BACK PAIN AFTER FALLING OFF OF LADDER WHILE TRYING TO INSTALL A CEILING FAN, WAS APPROX 4 STEPS UP WHEN HE LOST HIS BALANCE AND FELL BACKWARDS STRIKING A WINDOWSILL ON LOWER BBACK, DX: ACUTE ON CHRONIC LS BACK PAIN

200138673 29year old male WAS TRYING TO HANG A CEILING FAN AT HOME WHEN IT FELL ON HIM. DX:
CERVICAL STRAIN, THORACIC STRAIN.

200153632 50 year old female HX OF MS CEILING FAN FELL ON HEAD, PRESENTS WITH CONFUSION, HEAD
PAIN. DX: HEAD PAIN

200315385 64 year old male C/O SHOULDER PAIN S/P REACHING UP TO INSTALL A CEILING FAN AT HOME. DX:
SHOULDER PAIN

200529122 25year old male CUT TO [R] RING FINGER FROM CEILING FAN; HE WAS CHANGING IT FELL; DX: [R]
RING FINGER LACERATION

200427815 1month old female CELING FELL IN BECAUSE OF WATER LEAKAGE AND THE CEILING FAN FELL
ONTO PT. DX EYE? INJURY

200502133 80year old male WAS ON A LADDER WORKING ON A FAN AND FELL OFF DX: LEFT HIP FX

200719409 68year old male.FALLING DOWN FROM LADDER INSTALLING CEILING FAN.DX.HEAD TRAUMA
AND,CONT.LT.ANKLE

200648912 8year old male WAS HIT ON THE RIGHT SHOULDER WHEN A CEILING FAN FELL. DX: SHOULDER
LACERATION.

200737210 29year old female TWISTED NECK TRYING TO CATCH FALLING FAN, DX: NECK PAIN

200804044 79 year old male FELL YESTERDAY WHILE TRYING TO MOUNT A KITCHEN FAN, FELL OFF CHAIR HE
WAS STANDING ON HITTING HIS HEAD AND FACE, DX: ACUTE HEAD INJURY, FACIAL ABRASION,
FRACTURE TRANSVERSE LUMBAR VERTEBRA

200805056 45year old male WAS AT HOME AND HIS CEILING FAN FELL ON HIM. DX NECK AND BACK PAIN

200828084 7year old female HAD CELING FAN ACCDIENTALLY FALL ON HER HEAD AND FACE. DX FACIAL
LACERATION@

200906426 19year old male PRESENTS AFTER A CELING FAN FELL AND HE INHALED SOME DUST PARTICLES
AND EXPERIENCED CHEST TIGHTNESS AND WHEEZING, DX: MILD INTERMITTENT ASTHMA

200915596 48 year old female WAS HIT ON THE HAND BY A FALLING CEILING FAN. DX: RIGHT HAND FRACTURE.

210202899 30year old male WAS INSTALLING A CEILING FAN AND ACCIDENTALLY BEGAN TO COME DOWN LOST HIS BALANCE FALLING ON A BOX FRAME RESULTING IN LACERATION TO HIS HAND AND LACERATION TO RIGHT FOOT. DX: LACERATION RIGHT FOOT AND LACERATION RIGHT HAND

201020077 48year old male WAS PUTTING UP A CEILING FAN AT HOME WHEN HE WAS STRUCK IN THE WRIST WITH THE BLADE DX: CONTUSION TO WRIST

201108499 29year old male PATIENT HAVING RIGHT UPPER BACK PAIN SINCE A CEILING FAN FELL ON HIS RIGHT ARM TODAY DX: RIGHT UPPER BACK PAIN

201200650 37year old female PT STS CEILING FAN FELL FROM THE CEILING HITTING PT IN THE LEG. DX: LEG CONTUSION.

201200651 31year old male PT STS CEILING FANS FELL ON HIM WHILE IN BED HITT LEGS AND HIP. DX: LEG CONTUSION.

201234762 69year old female.WHILE SLEEPING CEILING FAN FELL ON FOREHEAD.DX.LAC.FOREHEAD

201110731 45year old male HAD A CEILING FAN FALL ONTO HIS HEAD FOUR WEEKS AGO CONTINUED HEADACHE DX: POST CONCUSSION SYNDROME

201231242 8year old male WAS AT HIS GRANDMA'S WHEN THE GLOBE FROM THE CELING FAN FELL AND PATIENT TRIED TO CATCH IT, CUTTING HIS RIGHT ARM. DX: LACERATION OF RIGHT FOREARM.

201251388 63year old female PRESENTS AFTER A FALL X2 WEEKS. PT STATES SHE WAS PUTTING UP A CEILING FAN WHEN SHE LOST HER BALANCE, FELL ONTO THE BED AND THEN ONTO HER BUTTOCKS ON THE CEMENT FLOOR. -HEAD STRIKE. DX: FALL, COCCYX CONTUSION

2019

2019

CPSC Case #

Narrative

190115444 4year old male WHO WAS AT HOME WHEN A CEILING FAN FELL FROM 8-1/2 TO 9 FEET HIGH. HE WAS BENDING OVER AT THE TIME, AND IT HIT HIM IN THE BACK. DX: LACERATION OF BACK.

190119288 5year old female EYE PAIN AND ABR NOSE, CEILING FAN FELL OFF CEILING & STRUCK FACE

190431484 25year old male C/O HEAD INJURY. PT WAS SITTING ON COUCH WHEN A CEILING FAN FELL & HIT HIM ON THE HEAD, -LOC.DX MINOR HEAD INJURY WITHOUT LOSS OF CONSCIOUSNESS.

190438414 31year old male WAS INSTALLING CEILING FAN WHEN IT FELL ON HEAD. -FALL -LOC +HEAD PAIN DX SCALP LAC

190442421 65year old female WAS SHOCKED BY A MALFUNCTIONING CEILING FAN SHOCK WENT THROUGH HER ARM AND THROUGH HER BACK ABOUT 6 FEET DX: ELECTRIC SHOCK INJURY

190504645 70year old male ON LADDER FIXING CEILING FAN WHEN HE FELL, 6-7 FT, LANDED ON SHOULDER COMPLAINS OF PAIN DX-CONTUSION RT SHOULDER, CONTUSION SCALP

190510351 3YR M PLAYING IN LIVING ROOM WHEN CEILING FAN FELL AND STRUCK HIM ON HEAD;DX SCALP LAC

190531689 30year old male HAD CEILING FAN FALL ONTO HEAD. NO LOC. DX: HEAD LACERATION

190534847 45YM MOVING FURNITURE HOME WHEN A FAN FELL FROM 4FT HEIGHT STRIKING HEAD W/O LOC YET H/A&NAUSEA SINCE, DX: CONCUSSION

190549199 5MO F CEILING FAN FELL, BOUNCED OFF THE WALL AND THE BED, BLADE HIT ABDOMEN;DX ABDOMINAL CONTUSION

190622032 9YR F SITTING AT HOME UNDER CEILING FAN, PIECE OF LIGHT FIXTURE FELL HITTING HER IN HAND;DX HAND LAC

190625745 18 year old male - A CEILING FAN FELL AND HIT PT ON THE FACE. DX LACERATION

190650411 60year old female CEILING FAN FELL ON HEAD, DX: INJ OF HEAD

190701002 A 46year old female STATES CEILING FAN FELL ON HEAD AT HOME, DX CONTUSION TO HEAD WITH HEMATOMA TO HEAD

190747973 12 year old female - FAN DROPPED ONTO PTS HEAD. DX HEAD INJURY

190804970 65year old male WAS STANDING ON HIS BED WORKING ON A CEILING FAN AND FELL ONTO THE FLOOR DX: CLOSED HEAD INJURY STRAINED NECK

190817677 23year old female PT REPORTS WAS SLEEPING AT A FRIED'S HOUSE WHEN A FAN FELL ON TOP OF HER DX: LAC RT EYEBROW

190840241 52 YO F STATES A BLADE FROM CEILING FAN FELL AND HIT HER ON TOP OF HEAD DX HEMATOMA SCALP

190857912 31 year old male WAS SLEEPING ON HIS STOMACH WHEN A CEILING FAN FELL ON HIS POSTERIOR SHOULDER, C/O SHOULDER PAIN, NO TRAUMATIC INJURY. DX: SHOULDER PAIN

190919502 35year old male PT STS A CEILING FAN DROPPED HITTING HIM ON RT HAND. DX: RT HAND LACERATION

190929754 39year old male HAD A WOODEN BLADE FROM A CEILING FAN FALL ONTO HEAD WHILE AT HIS GIRLFRIENDS HOUSE DX: CLOSED HEAD INJURY

190950625 42year old female PAIN IN NECK INSTALLING A CEILING FAN AT HOME. DX: NECK PAIN

190951511 40 year old male WITH NECK AND BACK PAIN AFTER THE CEILING FAN FELL AND HIT HIM IN THE BACK TONIGHT ABOUT 3 HOURS PRIOR TO ARRIVAL. PT STATES THAT HE WAS JUST LAYING IN THE BED AND IT HIT HIM. DX CERVICAL STRAIN, ACUTE THORACIC Myear old femaleASCIAL STRAIN

190962605 23 year old male HIT ON THE HEAD BY A CEILING FAN THAT FELL ON HIM ONE HOUR AGO, DX: HEAD INJURY

191000407 29year old female WAS AT HOME WITH A CEILING FAN FELL ONTO UPPER BACK AND HEAD DX: CONTUSION TO BACK CLOSED HEAD INJURY

191013492 45year old male WAS INSTALLING A CEILING FAN AND FELL OFF THE LADDER AT HOME DX: RIGHT LOWER LEG PAIN

191016376 59year old female ROLLED OUT OF BED AND HIT HEAD ON FANC/O NOT FEELING WELLDX PERSON
W/ FEARED COMPLAINT

191028710 6year old male A FAN AT SCHOOL FELL AND HIT PT IN HIS HEAD. DX CHI AND FOREHEAD
CONTUSION

191064043 55year old female C/O SHOULDER AND UPPER BACK HURTS SINCE CEILING FAN FELL ONTO HER. DX
SHOULDER AND UPPER BACK CONTUSION

191135383 56year old female FELL TAKING DOWN A CEILING FAN FELL OFF A STEP LADDER DX: FRACTURED
THORACIC VERTEBRA

191207804 34 year old male WITH LEFT NECK AND SHOULDER PAIN, PT REPORTS THAT A LARGE CRACK IN HIS
CEILING AROUND THE FAN FELL ON HIS LAST NIGHT, DX NECK PAIN LEFT SIDE, ACUTE PAIN OF LEFT
SHOULDER

191213587 29year old female WAS AT HOME WHEN A BLADE FROM A CEILING FAN FELL OFF ONTO FACE DX:
LACERATION TO FACE

200136653 50year old male.INSTALLING CEILING FAN FELL ON FACE.DX.LAC.RT.EYELID

200248853 43year old female TRIED TO TURN OFF CEILING FAN AND IT FELL ON HER HEAD. DX CLOSED HEAD
INJURY, CONCUSSION

200301513 67year old male.CEILING FAN FELL ON HEAD.DX.LAC.HEAD.

2018

2018

CPSC Case #

Narrative

180315431 89year old male EVAL OF R ANKLE, PT STS YESTERDAY MORNING @ 5AM CEILING FAN FELL OFF
FROM CEILING & HIT PT IN R ANKLE WHILE HE SLEPT DX R ANKLE PAIN

180349162 17 year old female CEILING FAN FELL ONT HEAD & SHOULDERS 1 WK AGO. HAS INCREASINGNECK
PAIN. DX NECK CONTUSION; SHOULDER CONTUSION

180440320 64year old male WAS PUTTING UP CEILING FANS IN HIS HOUSE YESTERDAY AND NOW HAS PAIN IN RIGHT SHOULDER DX SHOULDER PAIN

180537938 62year old male HAD A CEILING FAN FALL OUT OF THE CEILING ONTO THE DINING ROOM TABLE AND SHATTER PIECE OF GLASS WENT INTO LOWER LEG LACERATION LOWER LEG

180538758 49year old male-SCALP LAC-30# FAN PART FELL ON PT'S HEAD-LOCATION NS NASAL BONE OPEN FX.

180564056 74 year old female WAS HIT BY A CEILING FAN THAT FELL OUT FROM THE CEILING.

180614243 47 YO MALE HAD A CELING FAN FALL AND HIT HEAD. DX CLOSED HEAD INJURY

180624873 26 year old female CEILING FAN FELL FROM CEILING AND HIT PT DX: FACE LAC

180734576 32 year old male WAS HIT N HEAD BY A CEILING FALN 30 MIN AGO. C/O PAIN IN FOREHEAD. DX MILD CONCUSSION

180736744 9 year old female GLOBE ON CEILING FAN FELL BROKE LACERATED PTS LOWER LEG

180745122 32year old male PT STS HE WAS WORKING ON A FAN WHEN IT FELL HITTING LEG. DX: RIGHT ARM LACERATION.

180825547 69 YR OLD FEMALE HAD A FAN FALL ONTO HER LEG WITH SKIN TEAR TO LOWER LEG

180831642 14year old female WAS HIT IN THE HEAD BY BEDROOM CEILING FAN, NO LOC, CEILING FAN BLADE FELL AND HIT HIM IN THE HEAD, DX BLUNT HEAD INJURY;

180856312 A 3year old male WAS SITTING AT TABLE, CEILING FAN FELL ON HEAD, CONTUSION TO HEAD

181027614 11 YO M PT PLAYING IN HIS ROOM WHEN THE CEILING FAN FELL OFF THE CEILING LANDED ON PT CUTTING RT UPPER ARM DX 2CM LAC RT HUMERUS

181029186 16 year old male INJURED HEAD, WHILE IN BED, CEILING FAN FELL ON HIM, AT HOME, 2 WEEKS AGO. DX-CLOSED HEAD INJURY, CONCUSSION

181035707 47 year old female PT WAS STANDING ON A BED INSTALLING A CEILING FAN & LOST BALANCE & FELL OFF LANDING ON SHOULDER DX RIGHT SHOULDER PAIN

181039139 20YM RTS A FAN FELL ONTO HIS HEAD WHILE SLEEPING 1WA>>CHI
181246223 28year old male INTALLING A CEILING FAN AND IT FELL HITTING HEAD. / SCALP LAC
181249230 27year old female PAIN IN SHOULDER WHEN CEILING FAN FELL ONTO PATIENT AT HOME. DX: RT
SHOULDER PAIN

2017

2017

CPSC Case #

Narrative

170125189 LT SHOULDER STR. 25year old male CEILING FAN FELL ON SHOULDER AT HOME.

170332472 HIP CONT. 52year old female BEDROOM CEILING FAN FELL ONTO PATIENT WHILE SLEEPING AT
HOME.

170332473 CHI. 45year old female BEDROOM CEILING FAN FELL ONTO HEAD WHILE SLEEPING AT HOME.

170339774 28YF RTS THE LANDLORD CHANGED CEILING FAN THAT CONTAINED GLASS LIGHT WHICH FELL ON
TOP OF HER HEAD&IT SHATTERED C/O H/A&LHD'NESS>>CONCUSSION

170538937 19 MO FEMALE INJURED HEAD, CEILING FAN FELL ON HEAD. DX-CONTUSION SCALP

170543168 39 year old male UPPER BACK CONTUSION, CEILING FAN FELL HITTING HIS BACK

170544041 CLOSED HEAD INJURY 27year old female FAN FELL ONTO HEADDX: CHI

170553902 4year old female LAC HEAD- CEILING FAN FELL ON HEAD

170569130 15year old female NS INJ FACE- CEILING FAN FELL ON PT

170739878 60year old male ARRIVES C/O SHOULDER PAIN, PUTTING UP CEILING FAN, FELL DOWN 4FEET,
HURT SHOULDER DX-CONTUSION RT SHOULDER FALL

170740295 11year old male-PT TRYING TO FIX CEILING FAN WHEN THE GLASS PORTION FELL ONTOFACE
IMMEDIATE BLEEDING. DX- 7.5CM FOREHEAD LACERATION.

170832679 46 year old male HEAD & NECK PAIN AFTER HAVING A CEILING FAN FALL ON HEAD TODAYAT
HOME. DX CERVICAL STRAIN, CLOSED HEAD INJURY

170834181 A 16year old male STATES CEILING FAN FELL AND GLASS LITE COVER BROKE, LAC TO HAND

170851999 22 year old female INJURED HEAD, CEILING FAN FELL ON HEAD WHILE IN BED AT HOME. DX-
CLOSED HEAD INJURY

170853779 47year old female LAC FACE- MAKING BED, CEILING FAN FELL ON PT

170872595 62year old female REPORTS CEILING FAN FELL ON RT SIDE OF FACE. DX: RT EYE AND FACEPAIN.*

170916472 5month old male month old male SMELLED ELECTRICAL SMOKE COMING FROM PTS BEDROOM
THE CEILING FAN WAS SMOKING ROOM FILLED WITH SMOKE- TO ED FOR POSSIBLE SMOKE
INHALAT

170954722 12year old male WAS LYING ON HIS STOMACH ON BED WHEN A CEILING FAN FELL HITTING PT IN
BACK OF HEAD DX: HEAD LACERATION

171011622 63year old female HAD A SECTION OF A CEILING FAN FALL ONTO HEAD AT HOME CLOSED
HEADINJURY

171030985 14 year old female - CEILING FAN FELL ON PT. DX WRIST CONTUSION

171041926 61 year old male C/O HEAD & NECK PAIN AFTER CEILING FAN FELL ON HIM THIS AM.DX
CONCUSSION, CERVICAL STRAIN, CONTRUSION OF LT SHOULDER

171104924 36 year old female C/O DIZZINESS, LIGHTHEADEDNESS AND HEADACHE SINCE A FAN FELL STRILING
HER HEAD 5 DAYS AGO. DX CLOSED HEAD INJURY

171218478 CT,COCCYX.71year old female.WHILE WALKING GOT TANGLE WITHF CABLE OF FAN FALLING DOWN
ON FLOOR

2016

2016

CPSC Case #

Narrative

160112322 17year old female WAS SITTING AT HOME AND A GLOBE FROM A CEILING FAN FELL AND HIT PTIN
HEAD. HEAD INJURY*

160201019 47year old female SAW CEILING FAN FALLING AND PUT HAND UP TO BLOCK IT DX SPRAIN WRIST

160213484 61year old male STANDING ON A STOOL HANGING A CEILING FAN AND FELL OFF LACERATION TO
FACE

160360022 40year old female AT HOME STS CEILING FAN FELL ON PTS HEAD SAW SPOTS WHEN IT HIT NLOC
DX NECK STRAIN HEADACHE

160402495 40 year old female CEILING FAN FELL ON PT AT HOME DX; FOREHEAD LAC

160420785 15year old female CEILING FAN FELL ON HER; DX CHI, LAC FOREHEAD

160446536 42 YO F WAS TRYING TO REPAIR A CEILING FAN WHEN IT FELL ONTO HER HEAD/FACE AND ARM DX
HEAD INJ/LAC

160543849 25 YR OLD MALE HAD CEILING FAN CATCH FIRE AND PULLED IT DOWN BURNING HANDS, UNK IF
FIRE DEPT ATTEND

160550759 16 year old male HAD CEILING FAN FALL ONTO KNEEDX CONTUSION

160614263 55 year old female - CONCUSSION - CEILING FAN FELL AND HIT PT IN HEAD

160653230 12year old female HAD A PIECE OF A CEILING FAN FALL ONTO HEAD AT HOME CLOSED HEAD
INJURY

160653844 31year old male WITH HEAD INJURY AFTER A FAN FELL ON PT DX HEAD INJURY*

160704286 2 YO F PER month old male SHE WAS IN KITCHEN HEARD LOUD NOISE SAW THAT A LARGE FAN HAD
FALLEN ON THE PT AND CUT HER DX LT CHEEK LAC

160710135 9 year old male - A BLADE OF A CEILING FAN FELL AND HIT PTS HEAD. DX HEAD INJURY

160728421 CEILING FAN FELL ON PT'S HEAD. HEAD CONTUSION. 45 year old female*

160733450 2 month old female - FAN FELL ON PTS HEAD. DX HEAD INJURY

160812800 16month old female-PT WAS HOME WHEN LIGHT /CELING FAN FELL ONTO FOREHEAD NO LOC N/V.
LACERATION TO FOREHEAD. DX- 2CM FOREHEAD LACERATION.

160821384 4year old male LAC HEAD- GLASS LIGHT GLOBE FIXTURE FELL FROM CEILING FAN ONTO PT

160849617 28 YO M TRAUMA ALERT S/P CEILING FAN FELL ON HIS HEAD SHOULDER LOC DX FOREHEAD RT SHOULDER ABRASIONS

160853324 26year old male REPORTS THAT CEILING FAN FELL AND HIT HIM ON HEAD. HAS HEAD PAINNOW. LWOT. *

160857622 26 year old female DX LACERATION TO FOREHEAD - DUE TO FALLING CEILING FAN TODAY.

160942759 21 year old female WAS SITTING IN HER KITCHEN WHEN A CELING FAN FELL AND STRUCK HERHEAD C/O HEAD AND NECK PAIN DX CERVICAL STRAIN

160943402 70year old female HANGING A CEILING FAN AND FELL OFF THE LADDER AND SUSTAINED A CLAVICLE FX

161001944 LAC.HEAD.57year old female.REFERS A CEILING FAN FELL ON HEAD WHILE IN BED.

161005808 40 year old male DX SCALP LACERATION - S/P PT STOOD ON WASHING MACHINE INLAUNDROMAT WHEN CEILING FAN HIT HEAD.

161014365 44 year old male WAS HANGING A CELING FAN AT HOME AND FELL OFF LADDER LANDING ONLT SHOULDER. DX SHOULDER DISLOCATION @

161117756 4year old female HIT HEAD ON CEILING FAN; DX LAC FOREHEAD

161132359 46 year old female. SITTING IN HER SON'S CLASSROOM & THE CEILING FAN FELL ON PT FACE,LAC & NOSE SWELLING. DX: CLOSED FX OF NASAL BONE

170100833 55 year old female REPORTS CEILING FAN FELL ON HEAD & LATER SHE FELL DOWN SOME STAIRS & "PEOPLE" FELL ON TOP OF HER, CAUSING HEAD PAIN. DX HEAD INJURY/

2015

2015

CPSC Case #

Narrative

150140897 58 year old male NECK, SHOULDER, BACK PAIN. YESTERDAY PUT UP CEILING FAN. HAD ARMS ABOVE HEAD AND NECK BENT MOST OF DAY. DX: MUSCLE SPASM

150238105 21year old female-FACIAL AB-CUT WHEN A CEILING FAN FELL FROM CEILING-@ HOME

150432012 48 year old female CEILING FAN FELL, HIT PT, KNOCKED HER OUT OF CHAIR DX: NECK CONTUSION
150600442 72year old male TRYING TO HANG A CEILING FAN AT HOME AND SUSTAINED A FOREARM
LACERATION
150604880 33 year old female CEILING FAN FELL, HIT PT IN FACE DX; OPEN NOSE FX
150607319 PT STUCK HAND IN FAN. LACERATION HAND, RIGHT, COMPLICATED. 21 month old female*
150609233 R EYEBROW LAC/27YOWM AT HOME WAS ATTEMPTING TO INSTALL A CEILING FAN AND THE
BLADE OF THE FAN STRUCK HIM CAUSING LACERATION.
150614890 54year old male WITH 2ND AND 1ST DEGREE BURNS TO UPPER BODY AFTER CEILING FAN STARTED
A FIRE AND WALLS IN HOME WERE BURNING. FIRE DEPARTMENT RESPONDED.
150640946 11year old female-PT HAD A LARGE FAN THAT FELL FROM HEIGHT 10-12 FEET HITTING PT TO THE
HEAD. DX- CHI.
150658269 24 year old female WAS CLEANING CEILING FAN AT HOME WHEN IT FELL ONTO HERSHOULDER DX
CONTUSION
150662048 PT WAS WORKING ON A CEILING FAN AND FELT A PULL. LOW BACK PAIN.43 year old male*
150728242 49year old female LAC F'HD- FAN FELL FROM CEILING
150728355 81year old male LAC TO UPPER LIP WHEN CEILING FAN FELL HITTING PT IN FACE. DX LIPLAC
150728875 13 year old male WAS EATING AND CEILING FAN BLADE FELL AND HIT HIS HEADDX CONCUSSION
150803450 HAND ABR 9year old male MOVING FAN FELL INTO GLASS AT HOMEDX: ABR HAND
150822901 79year old female LAC HEAD- LIGHT FIXTURE FELL FROM CEILING FAN
150822955 28year old male STR NECK- INSTALLING CEILING FAN, FELL 4' FROM LADDER
150822988 36year old male FX RIBS- INSTALLING CEILING FAN, FELL ON TABLE
150847403 59YM UP ON A LADDER TRYING TO HANG A FAN WHEN FELL OFF STRIKING HEAD ONTO PIECE OF
WOOD NO LOC->CHI/LAC
150860118 41YM RTS A FAN FELL OFF THE CEILING HITTING HIS HEAD->>LAC

150860338 22YM WAS CHANGING CEILING FAN, FORGOT TO TURN OFF POWER, GRABBED A WIRE&FELT A SHOCK C/O HAND N&T/HA>>ELECTRIC SHOCK

150921508 37 year old male LAC TO HEAD WHEN CEILING FAN FELL FROM THE CEILING AND HIT HIM

150924235 60year old male WSHOULDER & HAND PAIN 2/2 FAN THAT FELL FROM CEILING HIT HIS SHOULDER & THEN HE FELL ON HIS SHOULDER.

151007421 76year old male STANDING ON A STEP LADDER TAKING DOWN CEILING FAN. FAN FELL AND PT FELL ON TOP OF IT CUTTING EAR. / EAR LAC

151055928 80year old female AT THE FLEA MARKET WHEN A PIECE OF THE CEILING FAN CAME DOWN ONTOHEAD LACERATION TO SCALP

151058126 63year old female AT HOME WHEN CEILING FAN WITH LIGHT FIXTURE FELL ON HEADDX HEAD INJURY, HEAD PAIN, ABRASION

151143412 48year old female STATES A LIGHT FIXTURE FROM CEILING FAN FELL & HIT TOP OF HEAD. DX; HEAD INJURY

151219137 LAC.LT.EAR.57year old female.CEILING FAN FELL HITTING EAR

151226435 FRAC LOW TRUNK 56year old male PUTTING UP FAN FELL OFF LADDER AT HOMEDX: FRAC HIP

151230025 10 year old male WAS AT COUSIN'S HOUSE & WAS LAYING IN THE LIVING ROOM WHEN THECEILING FAN LIGHT COVER FELL OFF & HIT HIM IN HEAD- VOMITED. DX; CHI

151243534 56year old female CONT HEAD - CEILING FAN FELL FROM CEILING

151243823 82YF SENT IN FROM ECF C/O H/A P GOT HIT BY FALLING LIGHT FIXTURE FROM THE FAN TO HEAD NO LOC>>CHI

151247421 12year old male AT HOME STS CEILING FAN FELL OFF BRACKET & HIT PT ON R SIDE OF HEAD DX HEAD INJURY

160222186 49year old male RAN INTO BURNING HOME TO SAVE PEOPLE AND THE CEILING COLLAPSED AND A CEILING FAN FELL ON HIM. +LOC. DX SMOKE INHALATION, ?FD ON SCENE.

2014

2014

CPSC Case #

Narrative

140309768 26year old male CHANGING A CIELING FAN AND FELL 8 FEET OFF A LADDER ONTO HEAD SKULL FX
140404086 37year old male WITH CHI FROM A FALLING FAN
140431646 73YO M WAS ON LADDER WORKING ON CEILING FAN WHEN FELL OFF LADDER. DX:SUBARACHNOID
HEMORRHAGE. ADMIT.
140455467 32year old male FELL OFF LADDER WHILE PUTTING UP CEILING FAN AT HOME CHEST CONTUSION
140459978 24year old female WITH FOREHEAD LAC 2/2 CEILING FAN FALLING ON HER TODAY. NO LOC.
140522693 59 YO M, C/O LT NECK, SHOULDER PAIN S/P CEILING FAN FALLING ONTO LT SHOULDER, DX LT
SHOULDER PAIN
140532910 67year old female SITTING IN A RESTAURANT WHEN A PIECE OF A CEILING FAN FELL ONTO EHAD
CLOSED HEAD INJURY
140533352 87year old male FELL & A FAN FELL ONTO CHEST C/O RIB PAIN DX: RIBS CONTUSION
140605800 LT CORNEA ABRASION. 82year old female GLOBE FROM CEILING FAN FELL OUT AND SCRATCHED
EYE.
140606131 A 10year old female STATES CEILING FAN FELL ON HEAD, DX HEAD INJURY
140621518 5year old female PT COMPLAINING OF FOREHEAD CONTUSION AFTER A CEILING FAN FELL ONPT'S
FOREHEAD AT HOME DX CONTUSION#
140662507 59YM FROM GROUP HOME AFTER CEILING FAN FELL STRIKING HIS BACK, PT DENIES PAIN>>MED
EVAL
140667358 70 YR OLD MALE TAKING DOWN A FAN AND EXTENDED NECK STRAINING IT
140703104 DX SCALP CONTUSION 38year old female FAN FELL ON TOP OF PATIENT'S HEAD DIZZY/NAUSEA
140712492 88 year old female DISTAL RADIUS FX. PT WAS AT HOME WHEN HER CEILING FAN FELL HITTING
HER WRIST, SPLINT APPLIED F/U ORTHO

140801604 7 year old male MOTHER STATES A BLADE FROM CEILING FAN FELL OFF A FEW DAYS AGO IT WAS LEANING AGAINST WALL PT FELL LANDED ON BLADE DX LACERATION HAND

140835976 68YR OLD MALE PUTTING UP A CEILING FAN AND STRAINED NECK WITH SPASM

140907489 62 YM INJURED TOE WHEN A CEILING FAN FELL ON LEFT FOOT. DX TOE LAC

140967705 46year old male LAC HAND WHILE INSTALLING CEILING FAN

141011313 19 year old female LAC TO FACE WHEN STRUCK BY A CEILING FAN

141104132 64year old male HAD A CEILING FAN FALL ON HEAD, CONCUSSION, AND SCALP CONTUSION

141217642 21 year old female LAC TO HEAD WHEN CEILING FAN FELL AND HIT HEAD

150216298 69year old female HAD A FAN FALL ONTO HEAD LACERATION TO SCALP

2013

2013

Narrative

CPSC Case

130159875 57 year old male DEVELOPED PAIN TO NECK & SHOULDER S/P HANGING A CEILING FAN ON THE CEILING LAST WEEK.*

130339950 54 year old female SUSTAINED A LACERATION OF THE SCALP FROM BEING STRUCK BY A FALLING FAN ABOUT THE WORKSHOP DOOR.

130348393 10month old female HAD CEILING FAN FALL ONTO HEAD AT HOMECLOSED HEAD INJURY

130441724 57YM REPORTS A CEILING FAN FELL ON TOP OF HIS HEAD NO LOC>>CHI/LAC

130508409 47 YO M WITH LOW BACK PAIN WHICH BEGAN WHILE HANGING CEILING FANS ON CEILING AT HOME. DX:LOW BACK MUSCLE STRAIN.

130633247 54year old male LOOKING UP AT A CIELING FAN THAT WAS WABBLBY AND FELL ONTO FACE LACERATION FACE

130713056 53year old female GOT HIT BY FALLING FAN DX: CONTUSION TO SHOULDER

130716773 24 YO M, C/O CEILING FAN FALLING ON HIS HEAD WHILE HE WAS REMOVING IT FRMO CEILING,FELL OFF LADDER (5 FT), NO LOC, DX SCALP LACERATION

130743728 67year old female HANDING CEILING FAN TO FRIEND ON LADDER;FRIEND FELL ONTO PTLAC LT
ELBOW DX: LAC/CONTUS ELBOW

130743737 78year old male INSTALLING FAN, FELL OFF LADDER;LANDED ON FRIEND; C/O LOW BACKPAIN DX:
BACK CONTUSOIN

130751372 47year old female WITH HEAD INJ 2/2 HER CEILING FAN FALLING AND HITTING HER IN THEHEAD.
NO LOC. REPORTS DIZZINESS & SEEING SPOTS.

130842821 47year old male WITH CHI FROM A FALLING FAN

130844229 37 year old female WAS AT A PARTY AT A PUBLIC FACILITY AND A CEILING FAN FELL ONTOHER
HEAD, DX: CHI

130901274 43 YO M, S/P ACCIDENT W/ CEILING FAN FALLING ON HIS HEAD YESTERDAY AT 8PM, HAD
BLEEDING INITIALLY, DX SCALP LACERATION

130917238 57 year old female C/O FAN FALLING AND STRIKING HER IN HEAD. DX FOREHEAD LAC

130938185 PAIN UP TRUNK 82year old female CEILING FAN IN HOUSE FELL STARTLING HER AT HOMEDX:
CHEST PAIN

130945163 37 year old female STATES A CEILING FAN FELL ON HER TOEDX:FRACTURE TOE

131129265 22year old male-CONCUSSION-A FAN MOTOR FELL HITTING PT'S HEAD-@ HOME

131221372 15year old male WITH THUMB LACERATION AFTER TRYING TO CATCH FALLING FAN DX
THUMBLACERATION **

140101020 33 Year old female WAS AT HOME AND THE CEILING FAN FELL ON HER. DX LOW BACK PAIN



Public Input No. 242-NFPA 70-2023 [Section No. 422.18(B)]

(B) Location.

~~No metal parts~~ No parts of ceiling-suspended (paddle) fans in bathrooms and shower spaces shall be located within a zone measured 900 mm (3 ft) horizontally and 2.5 m (8 ft) vertically from the top of the bathtub rim or shower stall threshold. This zone is all-encompassing and shall include the space directly over the tub or shower stall.

Statement of Problem and Substantiation for Public Input

Why was the term "metal" added here? My Public Input 198-NFPA 70-2019 was submitted merely to relocate the rules for paddles fans from Section 410.10(D)(1) to Article 422 where they correctly belong. My proposal never included the term "metal". No other PI were submitted to add the word "metal" here. First Revision No. 8364-NFPA 70-2021 makes no mention of adding the word "metal". My Public Comment No. 99-NFPA 70-2021 never sought to add the word "metal". Nor did any other Public Comments submitted. Committee Comment No. 8353-NFPA 70-2021 added the word "metallic". But why? No substantiation was given to add this word and exclude nonmetallic parts. Second Correlating Revision No. 61-NFPA 70-2022 changed "metallic" to 'metal'. but again, no substantiation was given for adding the word "metal" to this rule in the first place. In fact, this rule now conflicts with 410.10(D)(1) requirements. Section 410.10(D)(1) requires ALL parts of a paddle fan (with a light kit) to be excluded from this zone regardless if the parts are metal or not. These 2 rules should be applied in the same way. ALL parts of the paddle fan should be excluded from this zone as it has been since the rule was first added to 410.4(d) in the 1996 NEC edition. A wooden fan blade can be located in this zone, but a decorative metal tip on that same wooden fan blade cannot be there? How does this make any sense? A surface-mounted metal light fixture can be mounted on the ceiling or on the wall of the bathtub or shower stall, but that decorative metal tip on a paddle fan can't be there??????? 410.10(D)(1) and 422.18(B) should be worded in a way that excludes the same parts of the paddle fan.

Submitter Information Verification

Submitter Full Name: Russ Leblanc
Organization: Leblanc Consulting Services
Street Address:
City:
State:
Zip:
Submittal Date: Sat Jan 28 11:42:54 EST 2023
Committee: NEC-P17

Committee Statement

Resolution: [FR-8852-NFPA 70-2024](#)

Statement: The reference to metal parts is removed to correlate with the requirements in 410.10(D)(1)



Public Input No. 1872-NFPA 70-2023 [Section No. 422.31]

422.31 Disconnection of Permanently Connected Appliances.

For appliances that do not have a disconnecting means in accordance with 422.33 or 422.34, a disconnecting means shall be provided in accordance with 422.31(A), (B), or (C).

~~(A)– Rated at Not over 300 Volt-Amperes or~~ Appliances of any volt-ampere rating or not over 1/8 Horsepower.

For permanently connected appliances ~~rated at~~ of any volt-ampere rating or not over ~~300 volt-amperes or~~ 1/8 hp, the branch-circuit overcurrent device shall be permitted to serve as the disconnecting means where the switch or circuit breaker is within sight from the appliance or be capable of being locked in the open position in compliance with 110.25.

~~(B)– Appliances Rated over 300 Volt-Amperes:~~

~~For permanently connected appliances rated over 300 volt-amperes, the branch-circuit switch or circuit breaker shall be permitted to serve as the disconnecting means where the switch or circuit breaker is within sight from the appliance or be capable of being locked in the open position in compliance with 110.25 -~~

Informational Note: See 422.34 for appliances employing unit switches.

~~(C)–~~ Motor-Operated Appliances Rated over 1/8 Horsepower.

The disconnecting means shall comply with 430.109 and 430.110. For permanently connected motor-operated appliances with motors rated over 1/8 hp, the disconnecting means shall be within sight from the appliance or be capable of being locked in the open position in compliance with 110.25.

Exception: If an appliance is provided with a unit switch that complies with 422.34(A), (B), or (C), the switch or circuit breaker serving as the other disconnecting means shall be permitted to be out of sight from the appliance.

Statement of Problem and Substantiation for Public Input

(A) and (B) have had the identical requirements since the 2017 code and there is no reason to keep both first level subdivisions.

Submitter Information Verification

Submitter Full Name: Don Ganiere
Organization: none
Street Address:
City:
State:
Zip:
Submittal Date: Sun Aug 06 17:51:57 EDT 2023
Committee: NEC-P17

Committee Statement

Resolution: FR-8858-NFPA 70-2024

Statement: The text concerning the term lockable is revised to comply with the NEC Style Manual Section 3.2.5.

Sections 422.31(A) and (B) are consolidated as the requirements were redundant.

The title of 422.31(A) is revised for clarity to address appliances of any volt-ampere or appliances not over 1/8 horsepower.

Additionally, the language in (A) is revised to “branch-circuit overcurrent protective device” to correlate with the defined term in Article 100.



Public Input No. 2343-NFPA 70-2023 [Section No. 422.31]

422.31 Disconnection of Permanently Connected Appliances.

For appliances that do not have a disconnecting means in accordance with 422.33 or 422.34, a disconnecting means shall be provided in accordance with 422.31(A), (B), or (C).

(A) Rated at Not over 300 Volt-Amperes or $\frac{1}{8}$ Horsepower.

For permanently connected appliances rated at not over 300 volt-amperes or $\frac{1}{8}$ hp, the branch-circuit overcurrent device shall be permitted to serve as the disconnecting means where the switch or circuit breaker is readily accessible and within sight from the appliance or be capable of being locked in the open position in compliance with 110.25. For other than cord - and - plug connected appliances the disconnecting means shall meet the working space requirements of 110.26(A).

(B) Appliances Rated over 300 Volt-Amperes.

For permanently connected appliances rated over 300 volt-amperes, the branch-circuit switch or circuit breaker shall be permitted to serve as the disconnecting means where the switch or circuit breaker is readily accessible and within sight from the appliance or be capable of being locked in the open position in compliance with 110.25. For other than cord - and - plug connected appliances the disconnecting means shall meet the working space requirements of 110.26(A).

Informational Note: See 422.34 for appliances employing unit switches.

(C) Motor-Operated Appliances Rated over $\frac{1}{8}$ Horsepower.

The disconnecting means shall comply with 430.109 and 430.110. For permanently connected motor-operated appliances with motors rated over $\frac{1}{8}$ hp, the disconnecting means shall be within sight from the appliance or be capable of being locked in the open position in compliance with 110.25.

Exception: If an appliance is provided with a unit switch that complies with 422.34(A), (B), or (C), the switch or circuit breaker serving as the other disconnecting means shall be permitted to be out of sight from the appliance.

Statement of Problem and Substantiation for Public Input

Adding language to make it clear the disconnecting means for the appliance must be readily accessible as required in accordance with 408.4(A). Adding same language of 440.14 to 422.31(B) because it relieves the AHJ from interpreting that other than cord-and-plug appliance disconnects, the appliance disconnecting means must have the required working space in 110.26(A). This increases safety for the safe operation and maintenance of such equipment.

Submitter Information Verification

Submitter Full Name: Mike Holt
Organization: Mike Holt Enterprises Inc
Street Address:
City:
State:
Zip:
Submittal Date: Wed Aug 16 13:43:21 EDT 2023
Committee: NEC-P17

Committee Statement

Resolution: Section 4.1.1 of the NEC Style Manual states that the use of redundant references be avoided. Section 240.24 requires circuit breakers to be readily accessible, and 404.8 requires switches and circuit breakers used as switches to be readily accessible. Because appliances include a broad range of equipment and their disconnecting means vary, 110.26(A) requirements should be determined by the AHJ on a case-by-case basis.



Public Input No. 2527-NFPA 70-2023 [Section No. 422.31]

422.31 Disconnection of Permanently Connected Appliances.

For appliances that do not have a disconnecting means in accordance with 422.33 or 422.34, a disconnecting means shall be provided in accordance with 422.31(A), (B), or (C).

(A) Rated at Not over 300 Volt-Amperes or 1/8 Horsepower.

For permanently connected appliances rated at not over 300 volt-amperes or 1/8 hp, the branch-circuit overcurrent device shall be permitted to serve as the disconnecting means where the switch or circuit breaker is within sight from the appliance or ~~be capable of being locked in the open position in compliance with~~ lockable open in accordance with 110.25.

(B) Appliances Rated over 300 Volt-Amperes.

For permanently connected appliances rated over 300 volt-amperes, the branch-circuit switch or circuit breaker shall be permitted to serve as the disconnecting means where the switch or circuit breaker is within sight from the appliance or ~~be capable of being locked in the open position in compliance with~~ lockable open in accordance with 110.25.

Informational Note: See 422.34 for appliances employing unit switches.

(C) Motor-Operated Appliances Rated over 1/8 Horsepower.

The disconnecting means shall comply with 430.109 and 430.110. For permanently connected motor-operated appliances with motors rated over 1/8 hp, the disconnecting means shall be within sight from the appliance or ~~be capable of being locked in the open position in compliance~~ lockable open in accordance with 110.25.

Exception: If an appliance is provided with a unit switch that complies with 422.34(A), (B), or (C), the switch or circuit breaker serving as the other disconnecting means shall be permitted to be out of sight from the appliance.

Statement of Problem and Substantiation for Public Input

This Public Input is being submitted on behalf of the NEC Correlating Committee Usability Task Group in order to provide correlation throughout the document when a disconnecting means is required to be lockable open elsewhere in the code. The text is revised to comply with the NEC Style Manual. The NEC Style Manual Section 3.2.5 Consistent Application of Terms, 3.2.5.3 Lockable Open. Where a requirement specifies that a disconnecting means be capable of being locked in the open position, the phrase lockable open in accordance with 110.25 shall be used.

The Usability Task Group members are: Derrick Atkins, David Hittinger, Richard Holub, Dean Hunter, Chad Kennedy and David Williams.

Submitter Information Verification

Submitter Full Name: David Williams

Organization: Delta Charter Township

Street Address:

City:

State:

Zip:

Submittal Date: Sat Aug 19 21:32:21 EDT 2023

Committee: NEC-P17

Committee Statement

Resolution: [FR-8858-NFPA 70-2024](#)

Statement: The text concerning the term lockable is revised to comply with the NEC Style Manual Section 3.2.5.

Sections 422.31(A) and (B) are consolidated as the requirements were redundant.

The title of 422.31(A) is revised for clarity to address appliances of any volt-ampere or appliances not over 1/8 horsepower.

Additionally, the language in (A) is revised to “branch-circuit overcurrent protective device” to correlate with the defined term in Article 100.



Public Input No. 3734-NFPA 70-2023 [Section No. 424.3]

424.3– ~~XX~~ Other Articles.

Fixed electric space-heating equipment incorporating a hermetic refrigerant motor-compressor shall additionally comply with Table 424.3 unless amended by this article.

Table 424.3 Other Articles

<u>Equipment</u>	<u>Article</u>
Air-conditioning and refrigerating equipment	440 (Parts I, II, III, IV, V, VI)

Statement of Problem and Substantiation for Public Input

The section should be relocated for compliance with the NEC Style Manual Section 2.2.1.

Submitter Information Verification

Submitter Full Name: Derrick Atkins
Organization: Minneapolis Electrical JATC
Street Address:
City:
State:
Zip:
Submittal Date: Tue Sep 05 15:06:09 EDT 2023
Committee: NEC-P17

Committee Statement

Resolution: [FR-8880-NFPA 70-2024](#)

Statement: The section and associated table were renumbered to 424.8, in accordance with section 2.2.1 of the NEC Style Manual.



Public Input No. 3207-NFPA 70-2023 [Section No. 424.4(B)]

(B) Branch-Circuit ~~Conductor~~ Sizing.

The branch-circuit conductor(s) ampacity and the overcurrent protective device ampere rating shall not be less than 125 percent of the load of the fixed electric space-heating equipment and any associated motor(s).

Statement of Problem and Substantiation for Public Input

Added text for sizing the overcurrent protective device at 125% just like for the branch circuit conductors. It is recognized that 424.22 has overcurrent protection requirements, but this proposed language is more specific and adds clarity for Code users. Conductors have an ampacity and overcurrent protective devices have an ampere rating. Making these edits to make those points clear in the requirement.

Submitter Information Verification

Submitter Full Name: Mike Holt

Organization: Mike Holt Enterprises Inc

Street Address:

City:

State:

Zip:

Submittal Date: Wed Aug 30 11:19:49 EDT 2023

Committee: NEC-P17

Committee Statement

Resolution: The sizing of the overcurrent protective device is already addressed in other sections and would be redundant. Section 4.1.1 of the 2023 NEC Style Manual prohibits such redundancy.



Public Input No. 3733-NFPA 70-2023 [Section No. 424.6]

424.6– 2_ Listed Equipment.

Electric baseboard heaters, heating cables, duct heaters, and radiant heating systems shall be listed and labeled.

Statement of Problem and Substantiation for Public Input

The section should be relocated to 424.2 for compliance with the NEC Style Manual Section 2.2.1.

Submitter Information Verification

Submitter Full Name: Derrick Atkins
Organization: Minneapolis Electrical JATC
Street Address:
City:
State:
Zip:
Submittal Date: Tue Sep 05 15:05:07 EDT 2023
Committee: NEC-P17

Committee Statement

Resolution: [FR-9047-NFPA 70-2024](#)

Statement: The requirements for listing previously found in 424.6 and 424.102 were relocated to 424.2, in accordance with 2.2.1 of the NEC Style Manual. An informational note was added to alert the user of the importance of installing low voltage fixed electric space-heating equipment as a complete system.



Public Input No. 1910-NFPA 70-2023 [New Section after 424.12(B)]

424.12 (C) Bathtub and Shower Space

Heater and related equipment shall not be installed inside of the tub or shower or within a zone measured 900mm (3ft) horizontally from any edge of the bathtub or shower stall, including the space outside the bathtub or shower space below the zone.

The zone also includes the space measured vertically from the floor to 2.5m (8ft.) above the top of the bathtub rim or shower stall threshold. The identified zone is all-encompassing and shall include the space directly over the bathtub or shower stall and the space below the zone but not the space separated by a floor, wall, ceiling, room door, window or fixed barrier.

Statement of Problem and Substantiation for Public Input

The NEC clearly covers the installation of receptacles, switches and luminaires within the bathtub and shower areas. I have had people enquire about placing electric wall heaters or the indoor unit (evaporator) of a mini split system with in this area. I think the NEC needs to address this and avoid a potential hazard.

Submitter Information Verification

Submitter Full Name: IEC National
Organization: Clay Carroll - Ace Electric
Affiliation: IEC Central Ohio
Street Address:
City:
State:
Zip:
Submittal Date: Mon Aug 07 14:47:11 EDT 2023
Committee: NEC-P17

Committee Statement

Resolution: CMP17 shares the concerns that equipment should be properly rated for the environment; however, a blanket prohibition on equipment in or near bathtubs or showers is overly broad. Some types of heating equipment are listed for use in bathrooms, including near the shower or bathtub. Section 424.12(B) requires equipment to be listed for a wet or damp location if installed in one.



Public Input No. 2697-NFPA 70-2023 [Section No. 424.19(A)(2)]

(2) Heater Containing a Motor(s) Rated over $\frac{1}{8}$ Horsepower.

The disconnecting means required by 424.19 shall be permitted to serve as the required disconnecting means for both the motor controller(s) and heater under either of the following conditions:

- (1) Where the disconnecting means is in sight from the motor controller(s) and the heater and complies with ~~Part IX of Article 430~~, Part IX.
- (2) Where a motor(s) of more than $\frac{1}{8}$ hp and the heater are provided with a single unit switch that complies with 422.34(A), (B), (C), or (D), the disconnecting means shall be permitted to be out of sight from the motor controller.

Statement of Problem and Substantiation for Public Input

This Public Input is being submitted on behalf of the NEC Correlating Committee Usability Task Group in order to provide correlation throughout the document. The text is revised to to comply with the NEC Style Manual Section 4.1.4, regarding the use of Parts.

4.1.4 References to an Entire Article. References shall not be made to an entire article, except for the Article 100 or where referenced to provide the necessary context. References to specific parts within articles shall be permitted. References to all parts of an article shall not be permitted. The article number shall precede the part number.

The Usability Task Group members are: Derrick Atkins, David Hittinger, Richard Holub, Dean Hunter, Chad Kennedy and David Williams.

Submitter Information Verification

Submitter Full Name: David Williams

Organization: Delta Charter Township

Street Address:

City:

State:

Zip:

Submittal Date: Thu Aug 24 17:23:19 EDT 2023

Committee: NEC-P17

Committee Statement

Resolution: [FR-8886-NFPA 70-2024](#)

Statement: Editorial revisions were made to comply with section 4.1.4 of the 2023 NEC Style Manual.



Public Input No. 2528-NFPA 70-2023 [Section No. 424.19(B)(1)]

(1) Without Motor or with Motor Not over $\frac{1}{8}$ Horsepower.

For fixed electric space-heating equipment without a motor rated over $\frac{1}{8}$ hp, the branch-circuit switch or circuit breaker shall be permitted to serve as the disconnecting means where the switch or circuit breaker is within sight from the heater or ~~is capable of being locked in the open position in compliance-~~ lockable open in accordance with 110.25.

Statement of Problem and Substantiation for Public Input

This Public Input is being submitted on behalf of the NEC Correlating Committee Usability Task Group in order to provide correlation throughout the document when a disconnecting means is required to be lockable open elsewhere in the code. The text is revised to comply with the NEC Style Manual. The NEC Style Manual Section 3.2.5 Consistent Application of Terms, 3.2.5.3 Lockable Open. Where a requirement specifies that a disconnecting means be capable of being locked in the open position, the phrase lockable open in accordance with 110.25 shall be used.

The Usability Task Group members are: Derrick Atkins, David Hittinger, Richard Holub, Dean Hunter, Chad Kennedy and David Williams.

Submitter Information Verification

Submitter Full Name: David Williams

Organization: Delta Charter Township

Street Address:

City:

State:

Zip:

Submittal Date: Sat Aug 19 21:37:23 EDT 2023

Committee: NEC-P17

Committee Statement

Resolution: [FR-8887-NFPA 70-2024](#)

Statement: Editorial revisions were made to comply with section 3.2.5.3 of the NEC Style Manual requirements for consistent application of terms as it relates to "lockable open".



Public Input No. 2698-NFPA 70-2023 [Section No. 424.22(A)]

(A) Branch-Circuit Devices.

Electric space-heating equipment, other than motor-operated equipment required to have additional overcurrent protection by Article 430, Parts III and ~~IV~~ of ~~Article 430~~ or ~~IV~~ or Article 440, Parts III and VI of ~~Article 440~~, shall be permitted to be protected against overcurrent where supplied by one of the branch circuits in ~~Part II~~ of Article 210, Part II.

Statement of Problem and Substantiation for Public Input

This Public Input is being submitted on behalf of the NEC Correlating Committee Usability Task Group in order to provide correlation throughout the document. The text is revised to to comply with the NEC Style Manual Section 4.1.4, regarding the use of Parts.

4.1.4 References to an Entire Article. References shall not be made to an entire article, except for the Article 100 or where referenced to provide the necessary context. References to specific parts within articles shall be permitted. References to all parts of an article shall not be permitted. The article number shall precede the part number.

The Usability Task Group members are: Derrick Atkins, David Hittinger, Richard Holub, Dean Hunter, Chad Kennedy and David Williams.

Submitter Information Verification

Submitter Full Name: David Williams

Organization: Delta Charter Township

Street Address:

City:

State:

Zip:

Submittal Date: Thu Aug 24 17:24:51 EDT 2023

Committee: NEC-P17

Committee Statement

Resolution: [FR-8888-NFPA 70-2024](#)

Statement: Editorial revisions were made to comply with section 4.1.4 of the NEC Style Manual.



Public Input No. 99-NFPA 70-2023 [Section No. 424.44(E)]

(E) Ground-Fault Circuit-Interrupter Protection.

In addition to the requirements in 210.8, ~~ground-fault circuit-interrupter protection~~ GFCI protection for personnel shall be provided for cables installed in electrically heated floors of bathrooms, kitchens, and in hydromassage bathtub locations.

Statement of Problem and Substantiation for Public Input

Editorial changes only. No technical changes here. This revision merely seeks to mimic GFCI language used throughout the Code.

Related Public Inputs for This Document

<u>Related Input</u>	<u>Relationship</u>
<u>Public Input No. 100-NFPA 70-2023 [Section No. 424.45(E)]</u>	

Submitter Information Verification

Submitter Full Name: Russ Leblanc
Organization: Leblanc Consulting Services
Street Address:
City:
State:
Zip:
Submittal Date: Wed Jan 11 11:34:15 EST 2023
Committee: NEC-P17

Committee Statement

Resolution: FR-8891-NFPA 70-2024
Statement: Editorial revisions were made to use the acronym "GFCI" in accordance with section 2.1.2.9 of the NEC Style Manual.



Public Input No. 100-NFPA 70-2023 [Section No. 424.45(E)]

(E) Ground-Fault Circuit-Interrupter Protection.

In addition to the requirements in 210.8, ~~ground-fault circuit-interrupter protection~~
GFCI protection for personnel shall be provided.

Statement of Problem and Substantiation for Public Input

Editorial only. No technical changes here. This revision seeks to mimic GFCI language used through the Code

Related Public Inputs for This Document

<u>Related Input</u>	<u>Relationship</u>
<u>Public Input No. 99-NFPA 70-2023 [Section No. 424.44(E)]</u>	GFCI language

Submitter Information Verification

Submitter Full Name: Russ Leblanc
Organization: Leblanc Consulting Services
Street Address:
City:
State:
Zip:
Submittal Date: Wed Jan 11 11:36:13 EST 2023
Committee: NEC-P17

Committee Statement

Resolution: FR-8892-NFPA 70-2024

Statement: Editorial revisions were made to use the acronym "GFCI" in accordance with section 2.1.2.9 of the NEC Style Manual.



Public Input No. 235-NFPA 70-2023 [Section No. 424.47]

424.47 Label Provided by Manufacturer.

The manufacturers of electric space-heating cables shall provide marking labels that indicate that the space-heating installation incorporates electric space-heating cables and instructions that the labels shall be affixed to the ~~panelboards to~~ panelboard enclosure where the branch circuits originate to identify which branch ~~circuits supply~~ circuits supply the circuits to those space-heating installations. If the electric space-heating cable installations are visible and distinguishable after installation, the labels shall not be required to be provided and affixed to the ~~panelboards~~ panelboard enclosures

Additional Proposed Changes

<u>File Name</u>	<u>Description</u>	<u>Approved</u>
424.47_label.pdf	Example of 424.47 label	

Statement of Problem and Substantiation for Public Input

Installing labels on the panelboard (busbars) itself is certainly not the intent here. I believe the intent is to have these labels installed on the ENCLOSURE for the panelboard. This revision clarifies the intent.

Related Public Inputs for This Document

<u>Related Input</u>	<u>Relationship</u>
Public Input No. 238-NFPA 70-2023 [Section No. 408.5]	
Public Input No. 239-NFPA 70-2023 [Section No. 550.10(B)]	
Public Input No. 240-NFPA 70-2023 [Section No. 552.43(B)]	
Public Input No. 241-NFPA 70-2023 [Section No. 250.32(D)]	

Submitter Information Verification

Submitter Full Name: Russ Leblanc
Organization: Leblanc Consulting Services
Street Address:
City:
State:
Zip:
Submittal Date: Sat Jan 28 10:33:01 EST 2023
Committee: NEC-P17

Committee Statement

Resolution: [FR-8895-NFPA 70-2024](#)

Statement: The term “panelboard” was used incorrectly in previous versions of this section. The panelboard is the busbar assembly, aka the “guts.” The intent of this requirement is for the label to be applied to the panelboard’s enclosure, not the panelboard itself.

Editorial revisions were made to add clarity. A portion of the existing text was rewritten as an exception, as the previous language provided an alternative to the general requirement. Additional reference to 110.21 was added to ensure that the label is appropriate for the intended environment.

CAUTION

RISK OF ELECTRIC SHOCK. ELECTRICAL WIRING AND HEATING CABLES INSTALLED BELOW FLOOR. DO NOT PENETRATE FLOOR WITH NAILS, SCREWS ETC.

**Electric space-heating cables installed in these areas.
Avoid actions which may result in damage to the heating cables**

Room	Circuit#	Voltage	Watts	# of Units
Master Bath	4	120	300	3
Guest Bath	3	120	200	2



Public Input No. 3209-NFPA 70-2023 [Section No. 424.65]

424.65 Location of Disconnecting Means.

Duct heater controller equipment shall be accessible with the disconnecting means installed within sight from the controller or as permitted by 424.19(A B).

Statement of Problem and Substantiation for Public Input

The correct reference is “424.19(B) Heating Equipment Without Supplementary Overcurrent Protection,” not “424.19(A) Heating Equipment with Supplementary Overcurrent Protection.”

Submitter Information Verification

Submitter Full Name: Mike Holt

Organization: Mike Holt Enterprises Inc

Street Address:

City:

State:

Zip:

Submittal Date: Wed Aug 30 11:24:13 EDT 2023

Committee: NEC-P17

Committee Statement

Resolution: [FR-8899-NFPA 70-2024](#)

Statement: The duct heater may or may not have supplemental overcurrent protection, so 424.19(A) or (B) could apply.



Public Input No. 2699-NFPA 70-2023 [Section No. 424.80]

424.80 Scope.

The provisions in Part VIII of this article shall apply to boilers for operation at 600 volts, nominal, or less, in which heat is generated by the passage of current between electrodes through the liquid being heated.

Informational Note: See ~~Part V of~~ Article 495- for ~~,~~ Part V for over 1000 volts.

Statement of Problem and Substantiation for Public Input

This Public Input is being submitted on behalf of the NEC Correlating Committee Usability Task Group in order to provide correlation throughout the document. The text is revised to to comply with the NEC Style Manual Section 4.1.4, regarding the use of Parts.

4.1.4 References to an Entire Article. References shall not be made to an entire article, except for the Article 100 or where referenced to provide the necessary context. References to specific parts within articles shall be permitted. References to all parts of an article shall not be permitted. The article number shall precede the part number.

The Usability Task Group members are: Derrick Atkins, David Hittinger, Richard Holub, Dean Hunter, Chad Kennedy and David Williams.

Submitter Information Verification

Submitter Full Name: David Williams

Organization: Delta Charter Township

Street Address:

City:

State:

Zip:

Submittal Date: Thu Aug 24 17:26:30 EDT 2023

Committee: NEC-P17

Committee Statement

Resolution: [FR-8902-NFPA 70-2024](#)

Statement: Editorial revisions were made to comply with section 4.1.4 of the NEC Style Manual.



Public Input No. 3738-NFPA 70-2023 [Section No. 425.3]

425.3– ~~XX~~ Other Articles.

Fixed industrial process heating equipment incorporating a hermetic refrigerant motor-compressor shall additionally comply with Table 425.3.

Table 425.3 Other Articles

<u>Equipment</u>	<u>Article</u>
Motors, motor circuits, and controllers	430
Air-conditioning and refrigerating equipment	440 (Parts I through IV)

Statement of Problem and Substantiation for Public Input

The requirement should be relocated for compliance with the NEC Style Manual Section 2.2.1.

Submitter Information Verification

Submitter Full Name: Derrick Atkins
Organization: Minneapolis Electrical JATC
Street Address:
City:
State:
Zip:
Submittal Date: Tue Sep 05 15:16:15 EDT 2023
Committee: NEC-P17

Committee Statement

Resolution: [FR-8905-NFPA 70-2024](#)

Statement: The section and associated table were renumbered to 425.8, in accordance with section 2.2.1 of the NEC Style Manual. Specific Parts of Article 430 were added to comply with section 4.1.4 of the NEC Style Manual. Revisions made to update title of 425.8 and Table 425.8 in accordance with the NEC Style Manual.



Public Input No. 996-NFPA 70-2023 [Section No. 425.3]

425.3 Other Articles.

Fixed industrial process heating equipment incorporating a hermetic refrigerant motor-compressor shall additionally comply with Table 425.3.

Table 425.3 Other Articles

<u>Equipment</u>	<u>Article</u>
Motors, motor circuits, and controllers	430 (<u>Parts I through VII, and Parts IX through XIV</u>)
Air-conditioning and refrigerating equipment	440 (Parts I through IV)

Statement of Problem and Substantiation for Public Input

Section .1.4 of the NEC(r) Style Manual prohibits reference to an entire article, except for Article 100 or where required for context. As such, I've proposed what I believe to be applicable parts of Article 430 that would apply to these machines to comply with the style manual and improve usability of the Code.

Submitter Information Verification

Submitter Full Name: Richard Holub
Organization: The DuPont Company, Inc.
Street Address:
City:
State:
Zip:
Submittal Date: Thu Jun 08 14:21:09 EDT 2023
Committee: NEC-P17

Committee Statement

Resolution: [FR-8905-NFPA 70-2024](#)

Statement: The section and associated table were renumbered to 425.8, in accordance with section 2.2.1 of the NEC Style Manual. Specific Parts of Article 430 were added to comply with section 4.1.4 of the NEC Style Manual. Revisions made to update title of 425.8 and Table 425.8 in accordance with the NEC Style Manual.



Public Input No. 3739-NFPA 70-2023 [Section No. 425.6]

425.6– 2 Listed Equipment.

Fixed industrial process heating equipment shall be listed.

Statement of Problem and Substantiation for Public Input

The requirement should be relocated to 425.2 for compliance with the NEC Style Manual Section 2.2.1.

Submitter Information Verification

Submitter Full Name: Derrick Atkins

Organization: Minneapolis Electrical JATC

Street Address:

City:

State:

Zip:

Submittal Date: Tue Sep 05 15:17:27 EDT 2023

Committee: NEC-P17

Committee Statement

Resolution: [FR-8906-NFPA 70-2024](#)

Statement: The listing requirements of this article were relocated to 425.2 to comply with section 2.2.1 of the NEC Style Manual.



Public Input No. 2530-NFPA 70-2023 [Section No. 425.19(A)(1)]

(1) Heater Containing No Motor Rated over $\frac{1}{8}$ Horsepower.

The disconnecting means specified in 425.19 or unit switches complying with 425.19(C) shall be permitted to serve as the required disconnecting means for both the motor controller(s) and heater under either of the following conditions:

- (1) The disconnecting means provided is also within sight from the motor controller(s) and the heater.
- (2) The disconnecting means is ~~capable of being locked in the open position in compliance with~~ lockable open in accordance with 110.25.

Statement of Problem and Substantiation for Public Input

This Public Input is being submitted on behalf of the NEC Correlating Committee Usability Task Group in order to provide correlation throughout the document when a disconnecting means is required to be lockable open elsewhere in the code. The text is revised to comply with the NEC Style Manual. The NEC Style Manual Section 3.2.5 Consistent Application of Terms, 3.2.5.3 Lockable Open. Where a requirement specifies that a disconnecting means be capable of being locked in the open position, the phrase lockable open in accordance with 110.25 shall be used.

The Usability Task Group members are: Derrick Atkins, David Hittinger, Richard Holub, Dean Hunter, Chad Kennedy and David Williams.

Submitter Information Verification

Submitter Full Name: David Williams

Organization:

Street Address:

City:

State:

Zip:

Submittal Date: Sat Aug 19 21:41:18 EDT 2023

Committee: NEC-P17

Committee Statement

Resolution: [FR-8907-NFPA 70-2024](#)

Statement: Editorial revisions were made to comply with sections 3.2.5.3 and 4.1.4 of the NEC Style Manual.



Public Input No. 2531-NFPA 70-2023 [Section No. 425.19(A)(2)]

(2) Heater Containing a Motor(s) Rated over 1/8 Horsepower.

The disconnecting means required by 425.19(A)(1) shall be permitted to serve as the required disconnecting means for both the motor controller(s) and heater under either of the following conditions:

- (1) The disconnecting means is in sight from the motor controller(s) and the heater and complies with Part IX of Article 430.
- (2) Motor(s) of more than 1/8 hp and the heater are provided with disconnecting means. The disconnecting means shall be permitted to be out of sight from the motor controller and shall be ~~capable of being locked in the open position in compliance~~ lockable open in accordance with 110.25.

Statement of Problem and Substantiation for Public Input

This Public Input is being submitted on behalf of the NEC Correlating Committee Usability Task Group in order to provide correlation throughout the document when a disconnecting means is required to be lockable open elsewhere in the code. The text is revised to comply with the NEC Style Manual. The NEC Style Manual Section 3.2.5 Consistent Application of Terms, 3.2.5.3 Lockable Open. Where a requirement specifies that a disconnecting means be capable of being locked in the open position, the phrase lockable open in accordance with 110.25 shall be used.

The Usability Task Group members are: Derrick Atkins, David Hittinger, Richard Holub, Dean Hunter, Chad Kennedy and David Williams.

Submitter Information Verification

Submitter Full Name: David Williams
Organization: Delta Charter Township
Street Address:
City:
State:
Zip:
Submittal Date: Sat Aug 19 21:42:48 EDT 2023
Committee: NEC-P17

Committee Statement

Resolution: [FR-8907-NFPA 70-2024](#)

Statement: Editorial revisions were made to comply with sections 3.2.5.3 and 4.1.4 of the NEC Style Manual.



Public Input No. 2700-NFPA 70-2023 [Section No. 425.19(A)(2)]

(2) Heater Containing a Motor(s) Rated over $\frac{1}{8}$ Horsepower.

The disconnecting means required by 425.19(A)(1) shall be permitted to serve as the required disconnecting means for both the motor controller(s) and heater under either of the following conditions:

- (1) The disconnecting means is in sight from the motor controller(s) and the heater and complies with ~~Part IX of Article 430~~ , Part IX .
- (2) Motor(s) of more than $\frac{1}{8}$ hp and the heater are provided with disconnecting means. The disconnecting means shall be permitted to be out of sight from the motor controller and shall be capable of being locked in the open position in compliance with 110.25.

Statement of Problem and Substantiation for Public Input

This Public Input is being submitted on behalf of the NEC Correlating Committee Usability Task Group in order to provide correlation throughout the document. The text is revised to to comply with the NEC Style Manual Section 4.1.4, regarding the use of Parts.

4.1.4 References to an Entire Article. References shall not be made to an entire article, except for the Article 100 or where referenced to provide the necessary context. References to specific parts within articles shall be permitted. References to all parts of an article shall not be permitted. The article number shall precede the part number.

The Usability Task Group members are: Derrick Atkins, David Hittinger, Richard Holub, Dean Hunter, Chad Kennedy and David Williams.

Submitter Information Verification

Submitter Full Name: David Williams

Organization: Delta Charter Township

Street Address:

City:

State:

Zip:

Submittal Date: Thu Aug 24 17:27:52 EDT 2023

Committee: NEC-P17

Committee Statement

Resolution: [FR-8907-NFPA 70-2024](#)

Statement: Editorial revisions were made to comply with sections 3.2.5.3 and 4.1.4 of the NEC Style Manual.



Public Input No. 2532-NFPA 70-2023 [Section No. 425.19(B)]

(B) Heating Equipment Without Supplementary Overcurrent Protection.

(1) Without Motor or with Motor Not over $\frac{1}{8}$ Horsepower.

For fixed industrial process heating equipment without a motor rated over $\frac{1}{8}$ hp, the branch-circuit switch or circuit breaker shall be permitted to serve as the disconnecting means where the switch or circuit breaker is within sight from the heater, shall be permitted to be out of sight from the motor controller, and shall be ~~capable of being locked in the open position in compliance-~~ lockable open in accordance with 110.25.

(2) Over $\frac{1}{8}$ Horsepower.

For motor-driven fixed industrial process heating equipment with a motor rated over $\frac{1}{8}$ hp, a disconnecting means shall be located within sight from the motor controller or shall be permitted to be out of sight from the motor controller and shall be ~~capable of being locked in the open position in compliance-~~ lockable open in accordance with 110.25.

Statement of Problem and Substantiation for Public Input

This Public Input is being submitted on behalf of the NEC Correlating Committee Usability Task Group in order to provide correlation throughout the document when a disconnecting means is required to be lockable open elsewhere in the code. The text is revised to comply with the NEC Style Manual. The NEC Style Manual Section 3.2.5 Consistent Application of Terms, 3.2.5.3 Lockable Open. Where a requirement specifies that a disconnecting means be capable of being locked in the open position, the phrase lockable open in accordance with 110.25 shall be used.

The Usability Task Group members are: Derrick Atkins, David Hittinger, Richard Holub, Dean Hunter, Chad Kennedy and David Williams.

Submitter Information Verification

Submitter Full Name: David Williams

Organization: Delta Charter Township

Street Address:

City:

State:

Zip:

Submittal Date: Sat Aug 19 21:44:05 EDT 2023

Committee: NEC-P17

Committee Statement

Resolution: FR-8907-NFPA 70-2024

Statement: Editorial revisions were made to comply with sections 3.2.5.3 and 4.1.4 of the NEC Style Manual.



Public Input No. 2529-NFPA 70-2023 [Section No. 425.19 [Excluding any Sub-Sections]]

Means shall be provided to simultaneously disconnect the heater, motor controller(s), and supplementary overcurrent protective device(s) of all fixed industrial process heating equipment from all ungrounded conductors. Where heating equipment is supplied by more than one source, feeder, or branch circuit, the disconnecting means shall be grouped and identified as having multiple disconnecting means. Each disconnecting means shall simultaneously disconnect all ungrounded conductors that it controls. The disconnecting means specified in 425.19(A) and (B) shall have an ampere rating not less than 125 percent of the total load of the motors and the heaters and shall be ~~capable of being locked in the open position in compliance~~ lockable open in accordance with 110.25.

Statement of Problem and Substantiation for Public Input

This Public Input is being submitted on behalf of the NEC Correlating Committee Usability Task Group in order to provide correlation throughout the document when a disconnecting means is required to be lockable open elsewhere in the code. The text is revised to comply with the NEC Style Manual. The NEC Style Manual Section 3.2.5 Consistent Application of Terms, 3.2.5.3 Lockable Open. Where a requirement specifies that a disconnecting means be capable of being locked in the open position, the phrase lockable open in accordance with 110.25 shall be used.

The Usability Task Group members are: Derrick Atkins, David Hittinger, Richard Holub, Dean Hunter, Chad Kennedy and David Williams.

Submitter Information Verification

Submitter Full Name: David Williams
Organization: Delta Charter Township
Street Address:
City:
State:
Zip:
Submittal Date: Sat Aug 19 21:39:29 EDT 2023
Committee: NEC-P17

Committee Statement

Resolution: [FR-8907-NFPA 70-2024](#)
Statement: Editorial revisions were made to comply with sections 3.2.5.3 and 4.1.4 of the NEC Style Manual.



Public Input No. 2701-NFPA 70-2023 [Section No. 425.22(A)]

(A) Branch-Circuit Devices.

Fixed industrial process heating equipment, other than motor-operated equipment required to have additional overcurrent protection by Article 430, Parts III and IV of Article 430 or Part III of Article IV or Article 440, Part III, shall be permitted to be protected against overcurrent where supplied by one of the branch circuits in Article 210, Part II of Article 210.

Statement of Problem and Substantiation for Public Input

This Public Input is being submitted on behalf of the NEC Correlating Committee Usability Task Group in order to provide correlation throughout the document. The text is revised to to comply with the NEC Style Manual Section 4.1.4, regarding the use of Parts.

4.1.4 References to an Entire Article. References shall not be made to an entire article, except for the Article 100 or where referenced to provide the necessary context. References to specific parts within articles shall be permitted. References to all parts of an article shall not be permitted. The article number shall precede the part number.

The Usability Task Group members are: Derrick Atkins, David Hittinger, Richard Holub, Dean Hunter, Chad Kennedy and David Williams.

Submitter Information Verification

Submitter Full Name: David Williams

Organization: Delta Charter Township

Street Address:

City:

State:

Zip:

Submittal Date: Thu Aug 24 17:29:43 EDT 2023

Committee: NEC-P17

Committee Statement

Resolution: [FR-8911-NFPA 70-2024](#)

Statement: Editorial revisions were made to comply with section 4.1.4 of the NEC Style Manual.



Public Input No. 4168-NFPA 70-2023 [Article 426]

Article 426 Fixed Outdoor Electric Deicing and Snow-Melting Equipment

Part I. General

426.1 Scope.

This article covers fixed outdoor electric deicing and snow-melting equipment and the installation of these systems.

(A) Embedded.

Embedded in driveways, walks, steps, roads, and other areas.

(B) Exposed.

Exposed on drainage systems, bridge structures, roofs, roads, and other structures.

Informational Note: See ANSI/IEEE 515.1-2012, *Standard for the Testing, Design, Installation and Maintenance of Electrical Resistance Trace Heating for Commercial Applications*, for further information. See IEEE 844/CSA 293 series of standards for fixed outdoor electric deicing and snow-melting equipment.

(C) Combination. Combinations of embedded and exposed equipment in driveways, walks, steps, roads, bridge structures, and similar locations.

426.3 Other Articles.

Cord-and-plug-connected fixed outdoor electric deicing and snow-melting equipment shall additionally comply with Table 426.3.

Table 426.3 Other Articles

<u>Equipment</u>	<u>Article</u>
Appliances	422 (Parts I, II, III, IV, V)

426.4 Continuous Load.

Fixed outdoor electric deicing and snow-melting equipment shall be considered a continuous load.

426.6 Listing. A conductive pavement heating system shall be listed and installed in accordance with the installation instructions and conductive pavement mixture specifications.

Part II. Installation

426.10 General.

Equipment for outdoor electric deicing and snow melting shall be identified as suitable for the environment and installed in accordance with the manufacturer's instructions.

426.11 Use.

Electric heating equipment shall be installed in such a manner as to be afforded protection from physical damage.

426.12 Thermal Protection.

External surfaces of outdoor electric deicing and snow-melting equipment that operate at temperatures exceeding 60°C (140°F) shall be physically guarded, isolated, or thermally insulated to protect against contact by personnel in the area.

426.13 Identification.

The presence of outdoor electric deicing and snow-melting equipment shall be evident by the posting of appropriate caution signs or markings where clearly visible.

Part III. Resistance Heating Elements**426.20** Embedded Deicing and Snow-Melting Equipment.**(A)** Watt Density.

Panels or units shall not exceed 1300 watts/m² (120 watts/ft²) of heated area.

(B) Spacing.

The spacing between adjacent cable runs is dependent upon the rating of the cable and shall be not less than 25 mm (1 in.) on centers.

(C) Cover.

Units, panels, or cables shall be installed as follows:

- (1) On a substantial concrete, masonry, or asphalt base at least 50 mm (2 in.) thick and have at least 38 mm (1½ in.) of concrete, masonry, or asphalt applied over the units, panels, or cables; or
- (2) They shall be permitted to be installed over other identified bases and embedded within 90 mm (3½ in.) of concrete, masonry, or asphalt but not less than 38 mm (1½ in.) from the top surface; or
- (3) Equipment that has been listed for other forms of installation shall be installed only in the manner for which it has been identified.

(D) Secured.

Cables, units, and panels shall be secured in place by frames or spreaders or other approved means while the concrete, masonry, or asphalt finish is applied.

(E) Expansion and Contraction.

Cables, units, and panels shall not be installed where they bridge expansion joints unless provision is made for expansion and contraction.

426.21 Exposed Deicing and Snow-Melting Equipment.**(A)** Secured.

Heating element assemblies shall be secured to the surface being heated by identified means.

(B) Overtemperature.

Where the heating element is not in direct contact with the surface being heated, the design of the heater assembly shall be such that its temperature limitations shall not be exceeded.

(C) Expansion and Contraction.

Heating elements and assemblies shall not be installed where they bridge expansion joints unless provision is made for expansion and contraction.

(D) Flexural Capability.

Where installed on flexible structures, the heating elements and assemblies shall have a flexural capability that is compatible with the structure.

426.22 Installation of Nonheating Leads for Embedded Equipment.**(A)** Grounding Sheath or Braid.

Except as permitted under 426.22(B), nonheating leads installed in concrete, masonry, or asphalt shall be provided with a grounding sheath or braid in accordance with 426.27 or shall be enclosed in rigid metal conduit, electrical metallic tubing, intermediate metal conduit, or other metal raceways.

(B) Splice Connections.

The splice connection between the nonheating lead and heating element, within concrete, masonry, or asphalt, shall be located no less than 25 mm (1 in.) and no more than 150 mm (6 in.) from the metal raceway. The length of the nonheating lead from the metal raceway to the splice assembly shall be permitted to be provided without a grounding sheath or braid. Grounding continuity shall be maintained.

(C) Bushings.

Insulating bushings shall be used in the concrete, masonry, or asphalt where the leads enter a metal raceway.

(D) Expansion and Contraction.

Leads shall be protected in expansion joints in accordance with 300.4(H) or installed in accordance with the manufacturer's instructions.

(E) Emerging from Grade.

Exposed nonheating leads shall be protected by raceways or other identified means.

(F) Leads in Junction Boxes.

Not less than 150 mm (6 in.) of free nonheating lead shall be within the junction box.

426.23 Installation of Nonheating Leads for Exposed Equipment.**(A) Nonheating Leads.**

Power supply nonheating leads (cold leads) for resistance elements shall be identified for the temperature encountered. Not less than 150 mm (6 in.) of nonheating leads shall be provided within the junction box. Preassembled factory-supplied and field-assembled nonheating leads on approved heaters shall be permitted to be shortened if the markings specified in 426.25 are retained.

(B) Protection.

Nonheating power supply leads shall be enclosed in a rigid conduit, intermediate metal conduit, electrical metallic tubing, or other approved means.

426.24 Electrical Connection.**(A) Heating Element Connections.**

Electrical connections, other than factory connections of heating elements to nonheating elements embedded in concrete, masonry, or asphalt or on exposed surfaces, shall be made with insulated connectors identified for the use.

(B) Circuit Connections.

Splices and terminations at the end of the nonheating leads, other than the heating element end, shall be installed in a box or fitting in accordance with 110.14 and 300.15.

426.25 Marking.

Each factory-assembled heating unit shall be legibly marked within 75 mm (3 in.) of each end of the nonheating leads with the permanent identification symbol, catalog number, and ratings in volts and watts or in volts and amperes.

426.26 Corrosion Protection.

Ferrous and nonferrous metal raceways, cable armor, cable sheaths, boxes, fittings, supports, and support hardware shall be permitted to be installed in concrete or in direct contact with the earth, or in areas subject to severe corrosive influences, where made of material suitable for the condition, or where provided with corrosion protection identified as suitable for the condition.

426.27 Grounding Braid or Sheath.

Grounding means, such as copper braid, metal sheath, or other approved means, shall be provided as part of the heated section of the cable, panel, or unit.

426.28 Ground-Fault Protection.

Ground-fault protection shall be provided for fixed outdoor electric deicing and snow-melting equipment. The trip level of ground-fault protection shall be as specified by the manufacturer.

Part IV. Impedance Heating**426.30** Personnel Protection.

Exposed elements of impedance heating systems shall be physically guarded, isolated, or thermally insulated with a weatherproof jacket to protect against contact by personnel in the area.

426.31 Isolation Transformer.

An isolation transformer with a grounded shield between the primary and secondary windings shall be used to isolate the distribution system from the heating system.

426.32 Voltage Limitations.

The secondary winding of the isolation transformer connected to the impedance heating elements shall not have an output voltage greater than 30 volts ac.

426.33 Induced Currents.

All current-carrying components shall be installed in accordance with 300.20.

Part V. Skin-Effect Heating**426.40** Conductor Ampacity.

The current through the electrically insulated conductor inside the ferromagnetic envelope shall be permitted to exceed the ampacity values shown in Table 310.16, provided it is identified as suitable for this use.

426.41 Pull Boxes.

Where pull boxes are used, they shall be accessible without excavation by location in suitable vaults or above grade. Outdoor pull boxes shall be of watertight construction.

426.42 Single Conductor in Enclosure.

The provisions of 300.20 shall not apply to the installation of a single conductor in a ferromagnetic envelope (metal enclosure).

426.43 Corrosion Protection.

Ferromagnetic envelopes, ferrous or nonferrous metal raceways, boxes, fittings, supports, and support hardware shall be permitted to be installed in concrete or in direct contact with the earth, or in areas subjected to severe corrosive influences, where made of material suitable for the condition, or where provided with corrosion protection identified as suitable for the condition. Corrosion protection shall maintain the original wall thickness of the ferromagnetic envelope.

426.44 Equipment Grounding Conductor.

The ferromagnetic envelope shall be connected to an equipment grounding conductor at both ends; and, in addition, it shall be permitted to be connected to an equipment grounding conductor at intermediate points as required by its design.

Section 250.30 shall not apply to the installation of skin-effect heating systems.

Part VI. Conductive Pavement Heating Systems

426.60 General . Except as modified in this Part, conductive pavement heating systems shall comply with Parts I, II and VII of Article 426 and the following additional requirements.

426.62 Engineered Design .

The engineering design shall comply with all the following.

(A) Site Specific Design . Conductive pavement heating systems shall be designed and specified for specific installation site applications within the limits of the listing and manufacturer's installation instructions.

(B) Professional Engineer Required . The engineer shall be a licensed professional electrical engineer retained by the system owner or installer.

(C) Documentation . Documentation of the engineered design of the conductive pavement heating system shall be stamped and provided to the Authority Having Jurisdiction. The installation instructions, mixture specifications, and required conductivity test reports shall be provided to the Authority Having Jurisdiction.

(D) Additional Design Information . Additional stamped independent engineering reports detailing compliance of the design with applicable electrical standards and industry practice shall be provided upon request of the Authority Having Jurisdiction.

(E) Conformance Documentation . Conformance documentation shall include details of conformance of the design with the applicable parts of Article 426, or other articles of this Code.

426.64 Installation Engineering Supervision . Conductive pavement heating systems shall be installed under design engineering supervision and in accordance with the manufacturer's instructions. All documentation shall be provided to the Authority Having Jurisdiction.

426.66 Conductive Pavement Heating System

(A) Cover . Embedded electrodes shall be installed in accordance with the product listing and the following:

(1) On a substantial concrete, masonry, or asphalt base at least 100 mm (4 in.) thick and having at least 50 mm (2 in.) of conductive pavement applied under the electrodes and over the top of the electrodes; or

(2) The electrodes shall be permitted to be installed over other identified structural bases and embedded within 150 mm (6 in.) of conductive pavement with not less than 50 mm (2 in.) under the electrodes and over the top of the electrodes; or

(3) Equipment that has been listed for other forms of installation shall be installed only in the manner for which it has been identified.

(B) Secured . Electrodes and supply conductors shall be secured in place by frames or spreaders or other approved means while the conductive pavement is installed.

(C) Expansion and Contraction . Electrodes and supply conductors shall not be installed where they bridge expansion joints unless provision is made for expansion, contraction or other movement.

(D) Overtemperature . The conductive pavement system shall be monitored for surface temperatures and have overtemperature protection installed set not greater than 15 ° C (60 ° F). An overtemperature condition shall cause the power to the electrodes to be deenergized.

(E) Flexural Capability . Where installed on flexible structures, the electrodes and associated equipment shall have a flexural capability that is compatible with the movement of the

structure.

426.68- Installation of Nonheating Leads .

(A) Nonheating Leads . Power supply nonheating leads (cold leads) for connection to the electrodes shall be identified for the temperature encountered. Not less than 150 mm (6 in.) of nonheating leads shall be provided within junction boxes.

(B) Protection . Nonheating leads shall be enclosed in a rigid nonmetallic conduit or other approved means.

426.70 Electrical Connection.

(A) Electrode Connections . Electrical connections, other than factory connections of electrodes to nonheating leads, shall be made with insulated connectors identified for the use.

(B) Circuit Connections . Splices and terminations at the end of the nonheating leads, other than the electrode end, shall be installed in a box or fitting in accordance with 110.14 and 300.15.

426.72 Corrosion Protection . Ferrous and nonferrous metal raceways, boxes, fittings, supports, and support hardware shall be permitted to be installed in pavement or in direct contact with the earth, or in areas subject to severe corrosive influences, where made of material suitable for the condition, or where provided with corrosion protection identified as suitable for the condition.

426.74 Ground-Fault Protection . Ground-fault protection of equipment shall be provided for the electrodes used in conductive pavement heating systems. The trip level of ground-fault protection shall be as specified by the conductive pavement heating system manufacturer and listing.

426.76 Conductive Pavement Materials . The conductive pavement materials shall be mixed in accordance with the specifications from the installation instructions. The maximum and minimum limits for resistance or conductivity shall be provided in the installation instructions and in accordance with the listing.

426.78 Conductivity Testing . The conductive pavement material mixture shall be tested for resistance or conductivity and the test report provided to the Authority Having Jurisdiction. Final approval for the installation shall not be granted until all material test reports have been provided and reviewed.

426.80 Equipment Mounting . Structures or equipment mounted onto the conductive pavement surface shall be electrically bonded together and connected to the equipment grounding system.

426.82 Grounding and Bonding .

An 8 AWG bare copper ground ring shall be installed and connected to the equipment grounding conductors. The ground ring and associated connections shall comply with the following:

- (1) The conductors follow the contour of the perimeter surface.
- (2) Only listed splicing devices suitable for direct burial or concrete encasement, or exothermic welding are used.
- (3) The conductor(s) is 150 mm to 300 mm (6 in. to 12 in.) outside the perimeter of the conductive pavement heating system.
- (4) The conductor(s) is under the perimeter surface 100 mm to 150 mm (4 in. to 6 in.) below finished grade.

Part VII. Control and Protection

426.50– 90 Disconnecting Means.**(A)** Disconnection.

All fixed outdoor deicing and snow-melting equipment shall be provided with a means for simultaneous disconnection from all ungrounded conductors. Where readily accessible to the user of the equipment, the branch-circuit switch or circuit breaker shall be permitted to serve as the disconnecting means. The disconnecting means shall be of the indicating type and be capable of being locked in the open (off) position.

(B) Cord-and-Plug-Connected Equipment.

The factory-installed attachment plug of cord-and-plug-connected equipment rated 20 amperes or less and 150 volts or less to ground shall be permitted to be the disconnecting means.

426.51– 92 Controllers.**(A)** Temperature Controller with “Off” Position.

Temperature-controlled switching devices that indicate an “off” position and that interrupt line current shall open all ungrounded conductors when the control device is in the “off” position. These devices shall not be permitted to serve as the disconnecting means unless they are capable of being locked in the open position in compliance with 110.25.

(B) Temperature Controller Without “Off” Position.

Temperature controlled switching devices that do not have an “off” position shall not be required to open all ungrounded conductors and shall not be permitted to serve as the disconnecting means.

(C) Remote Temperature Controller.

Remote controlled temperature-actuated devices shall not be required to meet the requirements of 426.51(A). These devices shall not be permitted to serve as the disconnecting means.

(D) Combined Switching Devices.

Switching devices consisting of combined temperature-actuated devices and manually controlled switches that serve both as the controller and the disconnecting means shall comply with all of the following conditions:

- (1) Open all ungrounded conductors when manually placed in the “off” position
- (2) Be so designed that the circuit cannot be energized automatically if the device has been manually placed in the “off” position
- (3) Be capable of being locked in the open position in compliance with 110.25

426.54– 94 Cord-and-Plug-Connected Deicing and Snow-Melting Equipment.

Cord-and-plug-connected deicing and snow-melting equipment shall be listed.

Additional Proposed Changes

<u>File Name</u>	<u>Description</u>	<u>Approved</u>
Electrically_Conductive_Pavement_Heating_System_Defin_Submission.docx	PI 3479 definition of Conductive Pavement Heating System	
ISU_Rpt_10_21_self-heating_electrically_conductive_concrete_w_cvr.pdf	Iowa State University Research Report. This is in public domain with web site cited	

ECON_2023_NEC_Article_426_Draft_7.0_09062023.docx

in
substantiation.
Clean word file
for revisions to
Article 426 to
ensure Terra
errors are not
included and
clean
substantiation

Statement of Problem and Substantiation for Public Input

Introduction

A conductive concrete heating system that has been developed by the Iowa State University Department of Civil, Construction and Environmental Engineering with several pilot installations. These installations have the pavement surface with electrodes embedded within the pavement and placed at a set distance but not in direct contact with each other. The pavement mixture has additives, such as carbon fiber, included to enhance and increase the conductivity.

Existing NEC Does Not Provide Coverage

The present NEC requirements do not address this new technology. Because this technology is very different than present systems covered by Article 426 a new Part VI is proposed along with other changes specific to the conductive pavement applications. Many of these requirements were taken from those existing in Article 426 and adapted to this new technology.

Background

Over the past decade several research projects have been undertaken to develop alternate methods for snow melting and deicing paved surfaces. This includes sidewalks, steps to public buildings, bridges, bus stops, roadways and similar locations. The primary driver behind seeking the alternatives is the environmental impact of using chemicals as well as the cost in labor and equipment to facilitate snow or ice removal. Even with all the efforts from government and private entities, there are numerous minor to very serious injuries every year from slips and falls on icy or snow-covered walkways.

These projects have ranged from University of Alaska, Anchorage to Iowa State University Department of Civil, Construction and Environmental Engineering among others. There is also interest in implementing this technology by the FAA, transportation departments in Michigan, Colorado, Missouri and others as well as the US Department of Transportation. A web search will identify a number of research papers and other literature promoting the concept of heated pavements using other than the traditional methods. Many pavement materials, concrete or asphalt for example, have some level of conductivity. Regular Portland Cement Concrete (PCC) is conductive and is recognized as such by the NEC, for example, its use in a concrete encased electrode, reference 250.52(A)(3) and as a grounded surface when considering working space in 110.26(A) and 110.34(A). For further information on the research from Iowa State University, see the final report from October 2021 by Iowa State University at this web site:

<https://intrans.iastate.edu/research/completed/self-heating-electrically-conductive-concrete-demonstration-project/>

System Operation

Controls are provided to sense the presence of snow or ice to activate the system and monitor proper operation. When the control system senses snow or icing of the pavement, the system applies a voltage between the electrodes, for example 120 volts AC, and current then flows through the resistance of the conductive pavement generating heat. The temperatures required are only high enough to melt any accumulated snow or ice and to keep ice from forming on the surface. This is approximately 40°F. The system only applies power to the electrodes when needed as determined by

a snow switch and pavement temperature sensing units.

Proposed NEC Sections Technical Discussion

A new definition for Conductive Pavement Heating System has been added to Article 100 for this new technology. This has been recommended to be under the purview of CMP-17 and applicable to Article 426 only. This is to be considered under public input 3479.

The scope of Article 426 has been modified to accommodate this technology and provide coverage for this system that has a combination of embedded and exposed elements. Since this new technology is neither fully embedded nor fully exposed, a new item "(C)" has been added to incorporate systems that are a combination of embedded and exposed elements. The electrodes for this system are fully embedded into the pavement but since the pavement itself is part of the heating circuit, that is obviously exposed.

A new listing requirement, 426.6, has been added specific to this technology. The numbering and location are to comply with the NEC Style Manual. The Iowa Department of Transportation has engaged UL Solutions in developing the listing requirements, either as a modification to an existing standard or development of a new standard. That project is being conducted in parallel and coordinated with the proposed changes to the NEC as this Code cycle progresses.

No changes are proposed to Parts II through V as these parts are specific with different concepts and unrelated technologies. Due to the unique nature of this technology, it was determined a whole new part was needed, therefore the creation of the new Part VI and renumbering of the existing Part VI to Part VII. This is consistent with other parts in Article 426 that address a specific type of equipment or system.

New Part VI

The new part is recommended to become Part VI and the existing Part VI to be renumbered to Part VII with applicable renumbering of the three affected sections. The public input has made the applicable edits to the new Part VII and verified renumbering in cross references. Many of the requirements in this part were extracted from previous parts and modified to fit this new technology. The general sequence remained the same as in previous parts for consistency and usability.

A new general requirement is included to clarify what previous parts of Article 426 are to be included for installations of conductive pavement heating systems. In addition to the listing requirements, the design and oversight of the installation of conductive pavement heating systems is required to be conducted by a registered professional engineer. This is similar to existing NEC requirements found in 371.14 and 691.6. Having the design professional for the custom design of each system with the standardized specification and listing by a recognized testing laboratory provides the Authority Having Jurisdiction with a solid body of information to assist in the approval of the installation. This aspect was strongly recommended by the AHJs that are part of the Iowa DOT team working on this project.

There are clear documentation requirements for the initial design through the final installation to be provided to the Authority Having Jurisdiction for review and approval. The manufacturer's instructions, that will be part of the listing, and the specifications for the pavement batch mixing are required for the AHJ to evaluate conformance of the installation. This is aided by the requirement that the design engineer oversee the installation and provide to the AHJ specific reports as part of the project. One of these reports would be the testing results for the resistance or conductivity of the conductive pavement materials. The testing specifics are in development but will likely include fresh "wet" testing as well as testing after a curing period.

The primary hazards are potential shock if there is sufficient voltage on the surface where someone can contact it and have current through the body. This is considered for when both contact points are on the conductive pavement and when one is on the pavement and the is off the pavement on an adjacent surface. Part of the research completed by Iowa State University has determined this condition to be mitigated to a safe level and further evaluation will be part of the UL Solutions project.

The other hazard is from a surface becoming excessively hot. The level of heat required is only to melt snow or prevent icing, which is about 40°F per the research completed. The temperature limits set in the proposed requirements are 15°C or 60°F which are well below the 50°C or 122°F allowed in many

UL standards for contact without burns.

Code sections have been included for physical location of electrodes within the pavement for coverage of the conductive pavement material over and under the electrodes. In addition, requirements from transportation construction standards are provided to ensure a solid base under the pavement to mitigate ground movement. An alternative is permitted where the listing allows a different base or supporting system. Expansion and contraction are also covered to ensure that this action does not cause failures of the electrodes or associated equipment. Structures such as bridges are going to have natural movement and flexing and this needs to be accounted for in the design and installation.

The power supply lead and all controls are to be installed in non-metallic conduit such as PVC or RTRC to ensure physical protection of the conductors as well as isolation of the conductive pavement, so the current is controlled on the proper paths.

All the electrical components are required to be resistant to corrosion for the environment at the intended installation site. The electrodes in the design are specified to be a corrosion resistant stainless-steel material. The other metal electrical raceways and exposed components can have typical corrosion resistant construction or have supplemental corrosion protection if needed by the environmental conditions.

As provided in 426.28 today, ground fault protection is installed on all the power circuits to the electrodes. The ground fault trip levels would be the same as 426.28 in the 20 to 50 mA range. The trip level for the listed system will be part of the listing evaluation and listing specification. As with the other snow melting and deicing systems, Class A GFCI has a trip level such that the system would not remain in operation.

Since the pavement itself is purposefully conductive and part of the circuit, grounding and bonding will need to accommodate this fact. A means for a ground ring in the surrounding area where the conductive pavement is installed, similar to the equipotential deck for swimming pools and spas, is provided in the requirements. The equipment grounding conductors would then attach to this ground ring conductor as there is no place to attach within the conductive pavement without affecting the proper operation and control of current flow. This ring installation will provide a return path for any leakage from the electrically conductive pavement.

Related Public Inputs for This Document

<u>Related Input</u>	<u>Relationship</u>
<u>Public Input No. 3479-NFPA 70-2023 [New Definition after Definition: Concealed Knob-and-Tube Wi...]</u>	Definition for new Part
<u>Public Input No. 3479-NFPA 70-2023 [New Definition after Definition: Concealed Knob-and-Tube Wi...]</u>	

Submitter Information Verification

Submitter Full Name: Charles Mello
Organization: Cdcmello Consulting Llc
Affiliation: Iowa Department of Transportation
Street Address:
City:
State:
Zip:
Submittal Date: Wed Sep 06 19:16:10 EDT 2023
Committee: NEC-P17

Committee Statement

Resolution: CI-8998-NFPA 70-2024

Statement: CMP17 has reviewed public inputs 3479 and 4168 regarding conductive heated pavement systems and has decided to provide this committee input in order to solicit public review and comments.

CMP17 solicits comments regarding if pavement heating systems warrant specific requirements and/or separate a Part in Art 426, and do the specific requirements originally proposed in public inputs 3479 and 4168 sufficiently address the safety concerns. Currently, CMP 17 has initial concerns such as, but not necessarily limited to:

- 1) The lack of a product listing standard or outline of investigation clarifying appropriate product performance and safety requirements.
- 2) GFCI and/or GFPE protection or other shock protection measures
- 3) Grounding & bonding
- 4) Capacitive coupling
- 5) Scope of use
- 6) Accessible and acceptable contact voltages on or near the surface of the heated pavement, after damage or possible deterioration of the heated pavement such as wear, cracks, potholes, or penetrations into the heated pavement surface, such as signage, guard rails, benches, etc.
- 7) The use of a grounded or an ungrounded system
- 8) Limits on applied system voltage.
- 9) Concerns with lightning strikes.
- 10) Impact on local utilities.

After public comments are received, as well as progress of development of product safety standards, additional concerns may be presented for consideration.

Electrically Conductive Pavement Heating System Proposals

New definition in Article 100

Conductive Pavement Heating System. A system in which heat is generated by passing current between electrodes embedded within the pavement material and through the pavement material. The pavement material may be primarily of concrete, or asphalt, or the like, and is typically constructed as bridge structures, walks, steps, roads or parking areas.

Self-Heating Electrically Conductive Concrete Demonstration Project

Final Report
October 2021



IOWA STATE UNIVERSITY
Institute for Transportation

Sponsored by
Iowa Highway Research Board
(IHRB Project TR-724)
Iowa Department of Transportation
(InTrans Project 17-610)

About the Program for Sustainable Pavement Engineering and Research

The overall goal of the Program for Sustainable Pavement Engineering and Research (PROSPER) is to advance research, education, and technology transfer in the area of sustainable highway and airport pavement infrastructure systems.

About the Institute for Transportation

The mission of the Institute for Transportation (InTrans) at Iowa State University is to save lives and improve economic vitality through discovery, research innovation, outreach, and the implementation of bold ideas.

Iowa State University Nondiscrimination Statement

Iowa State University does not discriminate on the basis of race, color, age, ethnicity, religion, national origin, pregnancy, sexual orientation, gender identity, genetic information, sex, marital status, disability, or status as a US veteran. Inquiries regarding nondiscrimination policies may be directed to the Office of Equal Opportunity, 3410 Beardshear Hall, 515 Morrill Road, Ames, Iowa 50011, telephone: 515-294-7612, hotline: 515-294-1222, email: eooffice@iastate.edu.

Disclaimer Notice

The contents of this report reflect the views of the authors, who are responsible for the facts and the accuracy of the information presented herein. The opinions, findings and conclusions expressed in this publication are those of the authors and not necessarily those of the sponsors.

The sponsors assume no liability for the contents or use of the information contained in this document. This report does not constitute a standard, specification, or regulation.

The sponsors do not endorse products or manufacturers. Trademarks or manufacturers' names appear in this report only because they are considered essential to the objective of the document.

Iowa DOT Statements

Federal and state laws prohibit employment and/or public accommodation discrimination on the basis of age, color, creed, disability, gender identity, national origin, pregnancy, race, religion, sex, sexual orientation or veteran's status. If you believe you have been discriminated against, please contact the Iowa Civil Rights Commission at 800-457-4416 or the Iowa Department of Transportation affirmative action officer. If you need accommodations because of a disability to access the Iowa Department of Transportation's services, contact the agency's affirmative action officer at 800-262-0003.

The preparation of this report was financed in part through funds provided by the Iowa Department of Transportation through its "Second Revised Agreement for the Management of Research Conducted by Iowa State University for the Iowa Department of Transportation" and its amendments.

The opinions, findings, and conclusions expressed in this publication are those of the authors and not necessarily those of the Iowa Department of Transportation.

Technical Report Documentation Page

1. Report No. IHRB Project TR-724	2. Government Accession No.	3. Recipient's Catalog No.	
4. Title and Subtitle Self-Heating Electrically Conductive Concrete Demonstration Project		5. Report Date October 2021	
		6. Performing Organization Code	
7. Author(s) Amir Malakooti (orcid.org/0000-0001-8177-3571), Sajed Sadati (orcid.org/0000-0002-5512-5615), Halil Ceylan (orcid.org/0000-0003-1133-0366), Sunghwan Kim (orcid.org/0000-0002-1239-2350), Kristen Sara Cetin (orcid.org/0000-0003-2662-8480), Peter C. Taylor (orcid.org/0000-0002-4030-1727), Mani Mina (orcid.org/0000-0002-1500-9492), Bora Cetin (orcid.org/0000-0003-0415-7139), and Wei Shen Theh (orcid.org/0000-0002-4755-0961)		8. Performing Organization Report No. InTrans Project 17-610	
9. Performing Organization Name and Address Institute for Transportation Program for Sustainable Pavement Engineering and Research Iowa State University 2711 South Loop Drive, Suite 4700 Ames, IA 50010-8664		10. Work Unit No. (TRAIS)	
		11. Contract or Grant No.	
12. Sponsoring Organization Name and Address Iowa Highway Research Board Iowa Department of Transportation 800 Lincoln Way Ames, IA 50010		13. Type of Report and Period Covered Final Report	
		14. Sponsoring Agency Code IHRB Project TR-724	
15. Supplementary Notes Visit https://intrans.iastate.edu for color pdfs of this and other research reports.			
16. Abstract <p>Many transportation agencies allocate significant time and resources each year to remove ice and snow from their paved surfaces to achieve a safe, accessible, and operational transportation network. An electrically conductive concrete (ECON) heated pavement system (HPS) has been shown to be a promising alternative to conventional snow removal operations using snowplows and deicing chemicals, which is time-consuming, labor-intensive, and environmentally unfriendly.</p> <p>An ECON HPS utilizes the inherent electrical resistance of concrete to maintain the pavement surface at above-freezing temperatures and thus prevent snow and ice accumulation on the surface. Such a sustainable concrete pavement system improves its infrastructure resiliency by allowing it to be safe, open, and accessible during even harsh winter storms.</p> <p>The purpose of this study was to demonstrate the full-scale implementation of 10 ECON HPS slabs at the Iowa Department of Transportation headquarters' south parking lot in Ames, Iowa. This study consisted of system design and control, field implementation, and sensor instrumentation procedures for the construction of the ECON HPS, which took place during October 2018. A programmable logic controller (PLC) was designed, programmed, and utilized to remotely control, operate, and monitor the system, and the heating performance of the remotely operated ECON slabs was evaluated during the 2018 to 2021 winter seasons using the instrumented sensors under the snow and ice. The performance evaluation showed promising results in achieving snow- and ice-free pavement surfaces through several winter weather events.</p>			
17. Key Words concrete pavement system—electrically conductive concrete—heated pavement system—pavement construction—resiliency—resistive heating—winter maintenance		18. Distribution Statement No restrictions.	
19. Security Classification (of this report) Unclassified.	20. Security Classification (of this page) Unclassified.	21. No. of Pages 103	22. Price NA

SELF-HEATING ELECTRICALLY CONDUCTIVE CONCRETE DEMONSTRATION PROJECT

**Final Report
October 2021**

Principal Investigator

Halil Ceylan, Director
Program for Sustainable Pavement Engineering & Research (PROSPER)
Institute for Transportation, Iowa State University

Co-Principal Investigators

Sunghwan Kim, Associate Director
Program for Sustainable Pavement Engineering & Research (PROSPER)
Institute for Transportation, Iowa State University

Peter C. Taylor, Director
National Concrete Pavement Technology Center, Iowa State University

Mani Mina, Associate Professor
Industrial Design and Electrical and Computer Engineering, Iowa State University

Research Assistants

Amir Malakooti, Sajed Sadati, and Wei Shen Theh

Authors

Amir Malakooti, Sajed Sadati, Halil Ceylan, Sunghwan Kim,
Kristen Sara Cetin, Peter C. Taylor, Mani Mina, Bora Cetin, and Wei Shen Theh

Sponsored by
Iowa Highway Research Board
(IHRB Project TR-724)
Iowa Department of Transportation

Preparation of this report was financed in part
through funds provided by the Iowa Department of Transportation
through its Research Management Agreement with the
Institute for Transportation
(InTrans Project 17-610)

A report from
Institute for Transportation
Iowa State University
2711 South Loop Drive, Suite 4700
Ames, IA 50010-8664
Phone: 515-294-8103 / Fax: 515-294-0467
www.intrans.iastate.edu

TABLE OF CONTENTS

ACKNOWLEDGMENTS	xi
EXECUTIVE SUMMARY	xiii
1. INTRODUCTION	1
1.1. Report Content Overview	3
2. SUMMARY OF FIRST ECON HPS AT A US AIRPORT	4
3. PRECONSTRUCTION INVESTIGATIONS	8
3.1. Effects of Electrodes on Performance.....	8
3.2. Energy Requirements for Snow Melting in Ames, Iowa	25
4. DESCRIPTION OF SYSTEM DESIGN ELEMENTS	27
4.1. ECON Mix Design.....	27
4.2. Voltage Selection	28
4.3. Control System Design	28
4.4. Electrode Configuration Design	30
4.5. Sensor Selection.....	37
4.6. Cross Slope Design	37
5. IOWA DOT FULL-SCALE ECON HPS CONSTRUCTION DEMONSTRATION	38
5.1. Planning Considerations	38
5.2. Key Components of ECON HPS Technology	39
5.3. ECON HPS Design	39
5.4. Description of Materials	41
5.5. Instrumentation and Installation Methods	44
5.6. Construction Procedure.....	50
6. IOWA DOT ECON HPS PERFORMANCE EVALUATION.....	53
6.1. State of Practice	53
6.2. First Seasonal Evaluation (2019).....	53
6.3. Second Seasonal Evaluation (2020).....	56
6.4. Third Seasonal Evaluation (2021)	58
6.5. Structural Evaluation	61
7. SUMMARY, CONCLUSIONS, AND RECOMMENDATIONS	64
7.1. Conclusions.....	64
7.2. Recommendations for Implementation and Future Research Directions	65
REFERENCES	69
APPENDIX A. DRAFT STANDARD SPECIFICATION FOR ECON HPS CONSTRUCTION AT THE IOWA DOT SOUTH PARKING LOT.....	75
A.1. Description	75
A.2. Pavement Materials.....	76
A.3. Construction.....	78

A.4. Electrical Works for Power Supply Management and Operation Control Systems	81
APPENDIX B. ECON HPS APPROVAL PROCESS SUMMARY	83
APPENDIX C. DRAFT USER MANUAL FOR IOWA DOT ECON HPS	87

LIST OF FIGURES

Figure 1. Simplified ECON HPS concept.....	2
Figure 2. Construction of two ECON HPS test slabs at DSM.....	4
Figure 3. Pavement layers for ECON HPS test slabs at DSM.....	4
Figure 4. Current and temperature variations in pavement layers and ambient temperature on December 24, 2017	5
Figure 5. Current and temperature variations in pavement layers and ambient temperature on December 27, 2017	6
Figure 6. ECON HPS slab performance: (a) melting snow and (b) infrared thermography ($^{\circ}\text{F} = [^{\circ}\text{C} \times 1.8] + 32$).....	7
Figure 7. Electrodes used in the study (in. = mm/25.4).....	10
Figure 8. Electrode test in water: (a) tank dimensions and (b) setup.....	11
Figure 9. Electrode thermal performance in water: (a) with 2% sodium chloride and (b) without sodium chloride ($^{\circ}\text{F} = [^{\circ}\text{C} \times 1.8] + 32$).....	12
Figure 10. FE model mesh for a pair of 1 in. (25 mm) OD electrodes in water	12
Figure 11. Heat generation profile for 1 in. (25 mm) OD electrodes: (a) FE model, (b) experimental results, and (c) model validation ($^{\circ}\text{F} = [^{\circ}\text{C} \times 1.8] + 32$)	13
Figure 12. ECON prototype slab dimensions: (a) plan and (b) cross-sectional views	14
Figure 13. Construction of ECON prototype slabs: (a) fabricate mold, (b) cast normal PCC and roughen surface, (c) place temperature probe, and (d) cast and finish the ECON layer.....	15
Figure 14. Electrode test in water: (a) thermography imaging, (b) temperature versus time plot, and (c) current versus time plot (in. = mm/25.4, $^{\circ}\text{F} = [^{\circ}\text{C} \times 1.8] + 32$).....	17
Figure 15. Temperature increase rate for electrodes in water ($^{\circ}\text{F} = [^{\circ}\text{C} \times 1.8] + 32$)	18
Figure 17. ECON prototype slab results: (a) average surface temperature versus time and (b) corrected temperature increase per minute for electrodes (in. = mm/25.4, $^{\circ}\text{F}$ $= [^{\circ}\text{C} \times 1.8] + 32$).....	20
Figure 18. Temperature increase rate vs. perimeter for water and ECON tests (in. = mm/25.4, $^{\circ}\text{F} = [^{\circ}\text{C} \times 1.8] + 32$).....	21
Figure 19. Temperature increase rate per average initial cost of electrode (ft = m \times 3.281, in. = mm/25.4, $^{\circ}\text{F} = [^{\circ}\text{C} \times 1.8] + 32$)	24
Figure 20. Required heat flux for snow events at Ames, Iowa, from 1996 to 2019 ($\text{W}/\text{ft}^2 =$ $\text{W}/\text{m}^2 \div 10.76$).....	25
Figure 21. Snow event histogram in Ames, Iowa, in different temperatures ($^{\circ}\text{F} = [^{\circ}\text{C} \times$ $1.8] + 32$).....	26
Figure 22. Control system flowchart to determine applied voltage.....	29
Figure 23. Electrode setup: (a) perpendicularly reinforced with fiberglass bar at DSM and (b) without fiberglass bar reinforcement at Iowa DOT.....	31
Figure 24. Voltage lines developed by different electrodes: (a) smooth solid circular bar, (b) hollow circular bar, and (c) flat bar	32
Figure 25. FE model developed to simulate all pavement layers and the interaction between the surface and the environment	32
Figure 26. FE model of ECON HPS configuration with eight solid circular electrodes	34
Figure 27. Temperature distribution of three design configurations: with 10 (Test Section 1), 8 (Test Section 8), and 6 (Test Section 10) electrodes	35

Figure 28. Estimated average surface temperature of each configuration ($^{\circ}\text{F} = [^{\circ}\text{C} \times 1.8] + 32$)	36
Figure 29. Estimated power density of each configuration ($\text{W}/\text{ft}^2 = \text{W}/\text{m}^2 \div 10.76$)	36
Figure 30. ECON HPS test site: (a) construction location, (b) plan view, and (c) cross-section view.....	39
Figure 31. Electrode and sensor wiring and instrumentation: (a) anchor electrode to PCC layer, (b) wire electrodes, (c) install thermocouple sensor tree, (d) place thermocouple sensors, (e) install strain gauges, and (f) wire shed and sensors in shed	45
Figure 32. PLC control configurations: (a) electrode-based control, (b) slab-based control, and (c) system and relay wiring	48
Figure 33. Cooling fans installed on the relays.....	50
Figure 34. ECON HPS construction steps: (a) place C-3WR-C20 PCC placement, (b) screed PCC layer, (c) install electrodes, (d) place PVC conduit, (e) clean surface, (f) inspect ECON layer, (g) place and compact ECON layer with vibrating screed, and (h) spray curing compound on surface	51
Figure 35. ECON HPS heating performance: (a) southside slabs performance, (b) 2 in. (5 cm) of snow accumulation on surrounding slabs, (c) northside slab performance, and (d) infrared thermography ($^{\circ}\text{F} = [^{\circ}\text{C} \times 1.8] + 32$).....	54
Figure 36. Power density per square feet per resistivity of each slab.....	55
Figure 37. Slab surface temperature and air temperature vs. time.....	55
Figure 38. Thermal performance of ECON HPS slabs in the second seasonal evaluation ($^{\circ}\text{F} = [^{\circ}\text{C} \times 1.8] + 32$).....	56
Figure 39. Second year current measurements of each slab	57
Figure 40. Second year power density measurements of each slab	57
Figure 41. Second year slab resistivity measurements	58
Figure 42. Thermal performance of ECON HPS slabs in the third seasonal evaluation ($^{\circ}\text{F} = [^{\circ}\text{C} \times 1.8] + 32$).....	59
Figure 43. Third year current measurements of each slab	60
Figure 44. Third year power density measurements of each slab.....	60
Figure 45. Third year resistivity measurements of each slab.....	61
Figure 46. Iowa DOT FWD vehicle	62
Figure 47. Average FWD deflection plot for both the control and heated slabs	62
Figure A-1. Conceptual design of ECON HPS.....	75
Figure A-2. ECON construction procedure	78
Figure A-3. Broom or screed PCC surface	79
Figure A-4. Stainless steel 316L smooth electrodes.....	80
Figure B-1. Modification to address the overheating of relays	84
Figure B-2. Letter from a PE in electrical engineering regarding the wiring at Iowa DOT ECON HPS	85
Figure C-1. Step 2 screenshot	87
Figure C-2. Step 3 screenshot	87
Figure C-3. Step 4 screenshot	88
Figure C-4. Step 5 screenshot	88
Figure C-5. Step 6 screenshot	89
Figure C-6. Step 7 screenshot	89

LIST OF TABLES

Table 1. DSM concrete pavement system information.....	5
Table 2. Selected electrodes with the associated cost.....	10
Table 3. ECON mix proportions.....	16
Table 4. Current and resistivity of ECON prototype slabs.....	21
Table 5. Energy conversion efficiency calculation for ECON prototype slabs ($\text{kW}/\text{ft}^2 = \text{kW}/\text{m}^2 \div 10.764$).....	23
Table 6. DSM and Iowa DOT concrete pavement system information.....	27
Table 7. ECON mix proportions for DSM and Iowa DOT projects.....	28
Table 8. Electrode configuration in each slab.....	40
Table 9. ECON mix proportions for the Iowa DOT field implementation.....	42
Table 10. Types and numbers of sensors instrumented on 10 ECON slabs.....	43
Table 11. Types and numbers of sensors instrumented on one PCC slab.....	43

ACKNOWLEDGMENTS

The authors gratefully acknowledge sponsorship for this project from the Iowa Department of Transportation (DOT) and the Iowa Highway Research Board (IHRB), which provided matching funds for a related study, Project No. 1 Heated Airport Pavements, sponsored by the Federal Aviation Administration (FAA) Air Transportation Center of Excellence (COE) for the Partnership to Enhance General Aviation Safety, Accessibility, and Sustainability (PEGASAS). The authors would also like to thank the FAA COE PEGASAS.

The project technical advisory committee (TAC) members are gratefully acknowledged for their guidance, support, and direction throughout the research: Ahmad Abu-Hawash (Iowa DOT), Chris Brakke (Iowa DOT), Vanessa Goetz (Iowa DOT), Todd Hanson (Iowa DOT), Mike Harvey (Iowa DOT), Steve McMenammin (Iowa DOT), Kevin Merryman (Iowa DOT), Wes Musgrove (Iowa DOT), Scott Schram (Iowa DOT), Bob Younie (Iowa DOT), Brandon Billings (Cerro Gordo County Engineers Office), Brian Keierleber (Buchanan County Engineers Office), Wade Weiss (Greene County Engineers Office), Danny Waid (Iowa County Engineers Association Service Bureau [ICEASB]), Brian Moore (ICEASB), and Greg Mulder (Iowa Concrete Paving Association [ICPA]).

Mike Harvey, director of the Iowa DOT's Support Services Office Administrative Services Division; the Iowa DOT electricians; the FAA PEGASAS technical monitors, Matthew T. Brynick, Jeffrey S. Gagnon (interim), Benjamin J. Mahaffay (former), Charles A. Ishee (former), and Donald Barbagallo (former) for Heated Airport Pavements project; and Gary L. Mitchell of the American Concrete Pavement Association (ACPA) are gratefully acknowledged for their guidance, support, and direction throughout the study.

The authors would also like to express their sincere gratitude to other research team members from the Iowa State University Program for Sustainable Pavement Engineering and Research (PROSPER) at the Institute for Transportation for their assistance with the laboratory and field investigations. Many thanks to David Millard for the electrical consultation to the team, Gordon Smith (National Concrete Pavement Technology Center [CP Tech Center]), and Robert F. Steffes (CP Tech Center) for their guidance on construction, and ZOLTEK Corporation for providing carbon fiber, as well as Mannatt's, Inc. for being the contractor for this project.

EXECUTIVE SUMMARY

Many transportation agencies allocate significant time and resources each year to remove ice and snow from their paved surfaces to achieve a safe, accessible, and operational transportation network. An electrically conductive concrete (ECON) heated pavement system (HPS) has been shown to be a promising alternative to conventional snow removal operations using snowplows and deicing chemicals, which are time-consuming, labor-intensive, and environmentally unfriendly. An ECON HPS utilizes the inherent electrical resistance of concrete to maintain the pavement surface above freezing and thus prevent snow and ice accumulation on the surface. Such a sustainable concrete pavement system improves infrastructure resiliency by allowing it to be safe, open, and accessible even during harsh winter storms. The primary objective of this study was to demonstrate the full-scale implementation of 10 ECON HPS slabs at the Iowa Department of Transportation (DOT) headquarters' south parking lot in Ames, Iowa.

To identify the most electrically and thermally efficient type of electrode through experimental testing and theoretical analysis, several laboratory and preconstruction investigations were conducted regarding the influence of electrode size and geometry on the resistive heating performance of an ECON HPS. In addition, a theoretical formulation showing the relationship between thermal and electrical performance as well as the material properties in an ECON HPS was developed for the first time. Testing electrodes in water as a conductive medium was also found to be a quick, nondestructive, and cost-effective alternative method for monitoring the thermal performance of electrodes.

The field demonstration study consisted of developing the system design and identifying electrode and sensor instrumentation procedures for the construction of the ECON HPS, which took place during October 2018. The system design included the ECON mix design, electrode configuration design, sensor selection, and control system design using a programmable logic controller (PLC) to remotely control, operate, and monitor the system. Electrode and sensor instrumentation procedures included identifying suitability in terms of performance and finding appropriate sensors for monitoring system behavior to compare and contrast different electrode design configurations.

The heating performance of the remotely operated ECON slabs was evaluated during the 2018 through 2021 winter seasons using instrumented sensors located under the snow and ice. The performance evaluation showed promising results in producing snow- and ice-free pavement surfaces through several winter weather events.

Considering the variety of tested configurations, this study provides guidance on the design of ECON HPSs for various weather conditions, and its key findings and recommendations are as follows:

- As the largest ECON HPS implementation project, 10 ECON HPS test slabs with various electrode configurations were constructed in the south parking lot of the Iowa DOT headquarters. All the test slabs exhibited promising snow- and ice-free capabilities through a variety of winter weather events.

- The power density range for all the slabs was between 10.2 W/ft² (109.8 W/m²) and 45.6 W/ft² (491.5 W/m²), with an average of 24.6 W/ft² (265.1 W/m²).
- Increasing the electrode diameter in circular solid bars resulted in an increase in the power density for all electrode spacings.
- Based on the theory, the experimental study, and the finite element (FE) model, the temperature increase rate of an electrode is influenced by its surface contact area (perimeter).
- A theoretical formulation was developed to describe the ECON HPS thermal behavior.
- An increase in electrode size resulted in an increase in energy conversion efficiency.
- Falling weight deflectometer tests showed that the average heated pavement deflections were about 10% lower than those of regular concrete pavement slabs, indicating that the heated slabs are stiffer with a higher modulus.
- The best operational practice for heated pavements is to turn the system on before the snow event starts and/or before snow accumulation is initiated, and the operational time and consequent operational cost will decrease if this is done.

1. INTRODUCTION

Transportation networks often experience a significant reduction in mobilization capacity due to delays, sometimes resulting in a complete shutdown of some parts of a network, due to snow and ice accumulation during winter seasons (De Langhe et al. 2013). Departments of transportation (DOTs) and airports annually spend millions of dollars to remove snow and ice from pavements and maintain the safety of the transportation infrastructure (O'Donnell 2008). For example, US freeways, including interstates, experience 5% to 40% average speed reduction and 12% to 27% mobilization capacity reduction during snow and ice precipitation (FHWA 2017). Implementing heated pavement technology, especially in supporting critical infrastructure (e.g., airports, highways), can reduce these costs by increasing transportation network resiliency during the winter season, particularly as climate change continues to make winter seasons harsher, resulting in more extreme conditions in some regions (Nahvi et al. 2018).

Conventional methods for removing ice and snow include the use of snow-removal equipment and anti-icing or deicing chemicals (Baskas 2011). In 2019, the US consumed 27 million tons (24.5 million metric tons) of rock salt for roadway deicing purposes (Bolen 2020). Such methods are time-consuming, labor-intensive, and negatively impact the environment (Arabzadeh et al. 2017a, Ceylan et al. 2014), because deicing chemicals contaminate soil, surface runoff, and groundwater, thereby impacting the ecological system as a whole. It has been estimated that 50% of the world's arable land could be salinized by 2050, directly affecting the global food supply (Jamil et al. 2011). Deicing with chemicals not only affects the ecosystem but also increases the rate of corrosion of already aging infrastructure (Guo et al. 2019).

In Iowa, snow and ice removal are expensive components in winter road maintenance for the state DOT as well as for counties and cities. The Iowa DOT, alone, is responsible for snow and ice removal on more than 9,000 miles (14,000 km) of Iowa highways, uses approximately 900 snowplow trucks, and uses approximately 200,000 tons (181,000 metric tons) of rock salt each year in snow and ice removal on Iowa roadways.

Several innovative techniques have been proposed for facilitating the removal of ice and snow from surfaces by other than these conventional methods. These include hydronic-heated pavement systems (HHPSs) (Habibzadeh-Bigdarvish et al. 2019, Thurston et al. 1995), phase-change materials (PCMs) used in integrated pavement systems (Farnam et al. 2016), and electrically conductive concrete (ECON) heated pavement systems (HPSs) (Abdualla et al. 2016, Arabzadeh et al. 2018, Gomis et al. 2015, Sadati et al. 2017). An HHPS circulates heated glycol, potentially toxic and harmful to the environment, especially if leakage occurs, within embedded pipes to heat the pavement (Ceylan et al. 2014). PCM-integrated pavement systems utilize the heat of fusion generated by phase transformation to increase the pavement temperature. This technology has been found to have an adverse effect on both the dynamic elastic modulus and the compressive strength of concrete, and it is not applicable in harsh climates (Farnam et al. 2016). The ECON HPS has gained increasing attention in recent years based on promising results from full-scale field implementations at the Des Moines International Airport (DSM) in 2016 and the Iowa DOT headquarters in 2018 (Arabzadeh et al. 2017b, Ceylan et al. 2014, Malakooti et al. 2020, Xi and Olsgard 2000).

ECON, using regular portland cement concrete (PCC) combined with a conductive additive material (e.g., carbon fiber, steel shaving), relies on resistive heating of the ECON when embedded electrodes are subjected to an applied electric potential difference (voltage) (Abdualla et al. 2016). To properly facilitate the flow of electricity, a minimum dosage of conductive additive based on the mix's percolation threshold must be present in the mix (Gong et al. 2016, Kim et al. 2016, Liang and Yang 2017, Ravindren et al. 2019, Ceylan et al. 2014); 1% by volume has been found to be an adequate amount of carbon fiber for ECON HPS purposes (Notani et al. 2019, Sassani et al. 2018a).

The advantages of ECON HPS technology include electrification and automation of winter maintenance operations, environmental-friendliness, extended pavement life through elimination of deicing chemicals, and providing a safer platform for use by aircraft, vehicles, and pedestrians (Abdualla et al. 2016). Another application of ECON HPS is self-sensing and dynamic infrastructure monitoring using the operating conductivity range of ECON (Forintos and Czigany 2019, Nguyen et al. 2020, Tian et al. 2019, Zhang et al. 2020). Figure 1 is a conceptual diagram of an ECON HPS in which a pair of electrodes connected to the electrical source establishes a voltage gradient throughout the ECON material.

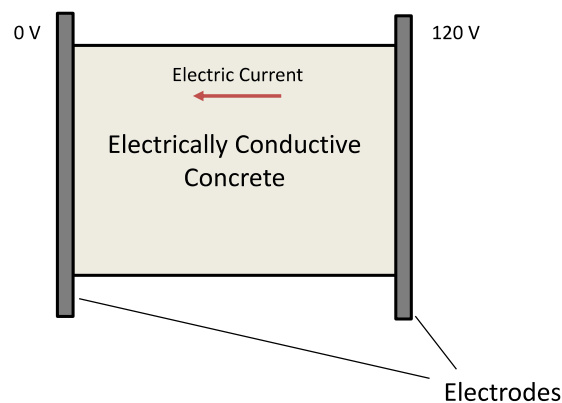

Sadati et al. 2020a, © 2020 Springer Ltd. All rights reserved., used with permission

Figure 1. Simplified ECON HPS concept

Given that weather conditions impact the performance of an ECON HPS, each specific region needs a particular design for ensuring the best system performance (Sadati et al. 2018). The design parameters for an ECON HPS include the thicknesses of the regular and conductive concrete layers, joint spacing, electrode spacing, and electrode size and shape. Among these parameters, electrode spacing and electrode size and shape are those unique to the ECON HPS design and not required for conventional rigid pavement systems. Electrodes, which are essential parts of the ECON HPS design, should exhibit an acceptable level of electrical conductivity to convey electrical current from a power supply into the ECON to increase the surface temperature to a value above the freezing point (41°F [5°C]) and melt accumulated ice and snow on the ECON surface. Adequate bonding between the electrodes and the ECON is critical for achieving satisfactory resistive heating for this system (Chen and Gao 2012, Hou et al. 2007, Tian and Hu 2012).

The objective of this study was to construct, demonstrate, and monitor a full-scale implementation of the largest-to-date operational ECON HPS using different electrode configurations. Ten full-scale slabs were constructed at the south parking lot entrance of the Iowa DOT headquarters in Ames, Iowa, as part of a reconstruction project. These slabs contained various electrode configurations with different spacings, sizes, and shapes to evaluate their effect on the energy and thermal performance of the ECON HPS. Along with the 10 ECON HPS slabs, the test setup included standard concrete slabs as control sections to compare the structural performance of the ECON HPS to standard rigid pavements.

1.1. Report Content Overview

The remainder of this report is structured as follows:

- Chapter 2. Summary of First ECON HPS at a US Airport
- Chapter 3. Preconstruction Investigations
- Chapter 4. Description of System Design Elements
- Chapter 5. Iowa DOT Full-Scale ECON HPS Construction Demonstration
- Chapter 6. Iowa DOT ECON HPS Performance Evaluation
- Chapter 7. Summary, Conclusions, and Recommendations
- References
- Appendix A. Draft Standard Specification for ECON HPS Construction at The Iowa DOT South Parking Lot
- Appendix B. ECON HPS Approval Process Summary
- Appendix C. Draft User Manual for Iowa DOT ECON HPS

2. SUMMARY OF FIRST ECON HPS AT A US AIRPORT

This chapter describes the experimental setup of the ECON HPS test slabs at the DSM and the temperature and electric current values measured during selected previous snowfall events. Two slabs were constructed at the DSM site in November 2016 (Figure 2) for evaluating the design and construction processes of a carbon fiber-based ECON HPS and the testing system performance in terms of its heating capacity and energy use. (The material and equipment used for this project are reported in (Abdualla et al. 2018 and Sassani 2018b).



Figure 2. Construction of two ECON HPS test slabs at DSM

The constructed slabs were 149.6 in. (3.8 m) wide and 181.1 in. (4.6 m) in length, and the total concrete thickness was 7.5 in. (19 cm), comprised of 3.5 in. (8.9 cm) ECON for the top layer and 4 in. (10.1 cm) standard concrete for the bottom layer (Figure 3).



Sadati et al. 2020a, © 2020 Springer Ltd. All rights reserved., used with permission

Figure 3. Pavement layers for ECON HPS test slabs at DSM

Table 1 shows the slab dimensions, thicknesses, and construction time.

Table 1. DSM concrete pavement system information

Items	DSM
Slab dimensions	12.5 ft (3.8 m) × 15 ft (4.6 m)
Number of slabs	2
ECON thickness	3.5 in. (8.9 cm)
PCC thickness	4 in. (10.1 cm)
Electrode type	Angle
Electrode spacing	3 ft (91.4 cm)
Construction time	November 2016

Abdualla et al. (2018) provided a detailed description of construction techniques and system requirements for these ECON HPS slabs. The pavement design was based on Federal Aviation Administration (FAA) requirements for a general aviation apron area. The operation control and the data acquisition systems were installed in a nearby existing airplane hangar belonging to the DSM. The voltage applied to each pair of electrodes was 240 VAC; an existing electrical power supply system was used to operate the slabs. The Iowa DOT construction was five times larger than the DSM project, and this led to construction challenges that are presented and discussed in Chapter 5.

The ECON HPS at DSM was energized during observed snowfall events, and measured values of the electric current and temperature in different pavement system layers are shown in Figure 4 and Figure 5 for testing on December 24 and 27, 2017, respectively.

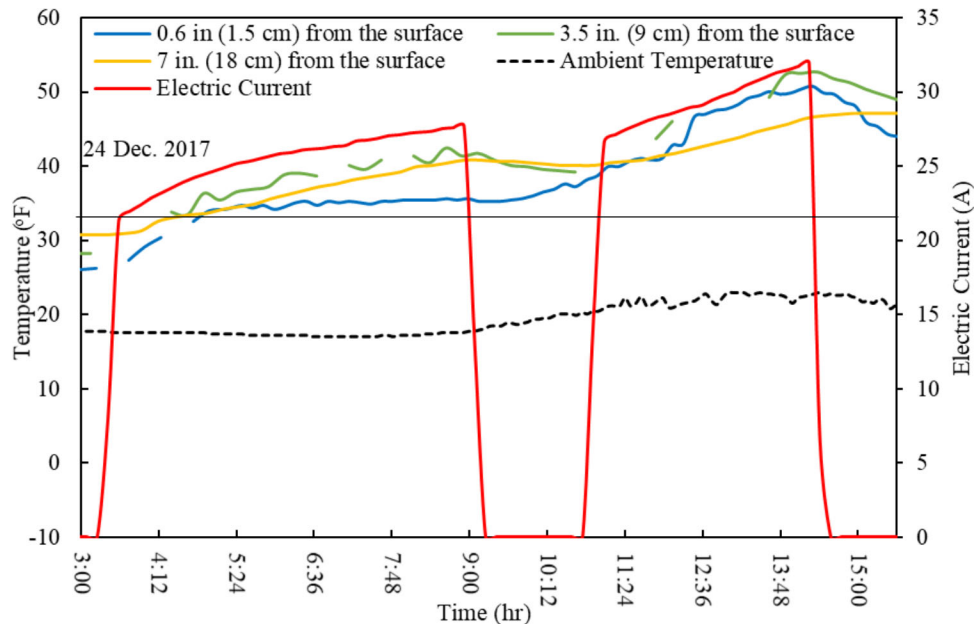

Sadati et al. 2020a, © 2020 Springer Ltd. All rights reserved., used with permission

Figure 4. Current and temperature variations in pavement layers and ambient temperature on December 24, 2017

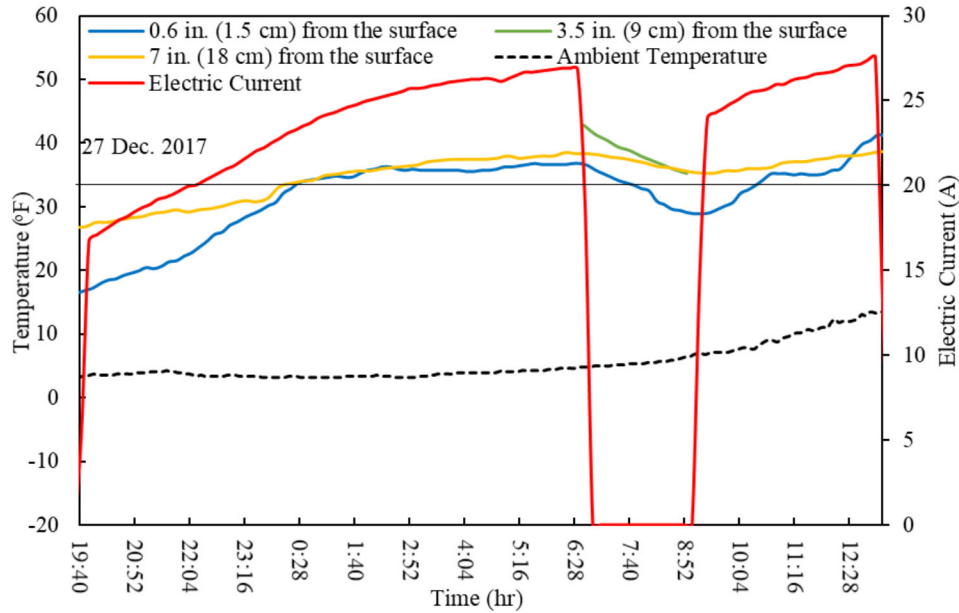

Sadati et al. 2020a, © 2020 Springer Ltd. All rights reserved., used with permission

Figure 5. Current and temperature variations in pavement layers and ambient temperature on December 27, 2017

It should be noted that because of the existence of an electric current in the ECON layer that could interfere with the sensor readings, there are some missing values for one of the sensors located 3.5 in. (9 cm) below the pavement surface. However, considering the number of sensors and the 10-minute sampling interval, the other measured data were found to be sufficient for this study.

As shown in Figure 4 and Figure 5, as soon as the system was turned on, the electric current value increases, producing a continuous increase in pavement temperature, with temperatures in the deeper pavement layers initially higher than those in surface layers. Given that the surface of the pavement experiences the largest heat loss, the sensors closest to the surface are usually indicative of the lowest temperatures during the winter season before the system is turned on. The ECON layer thickness was 3.5 in. (9 cm), and given that the electrodes were placed at the bottom of this layer, the bottom of the ECON layer heated faster, and the temperature at a 3.5 in. (9 cm) depth was higher than the others when the system was energized. When the system was turned off (i.e., the current value dropped to zero), the pavement temperature began to decrease faster at the surface because of heat loss due to convection, except when solar radiation heated the surface.

Figure 6 shows the system's performance during a 1.5 in. (4 cm) snow event on January 24, 2017.



(a)

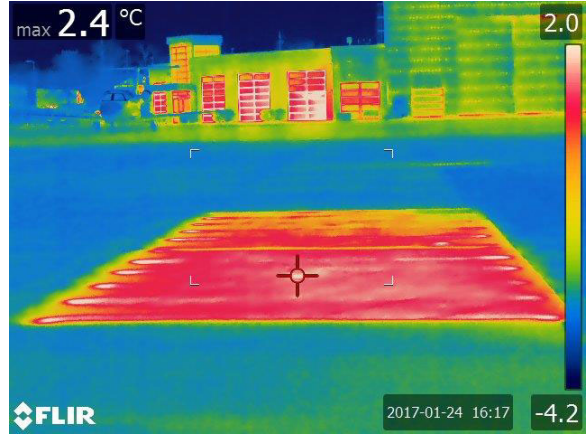

(b)

Figure 6. ECON HPS slab performance: (a) melting snow and (b) infrared thermography
($^{\circ}\text{F} = [^{\circ}\text{C} \times 1.8] + 32$)

3. PRECONSTRUCTION INVESTIGATIONS

3.1. Effects of Electrodes on Performance

A laboratory investigation was conducted to see the effects of electrode configuration on the electrical and thermal performance of an HPS. Electrodes, which are essential parts of the ECON HPS design, should exhibit an acceptable level of electrical conductivity to convey electrical current from a power supply into the ECON to increase the surface temperature to above the freezing point (41°F [5°C]) and melt accumulated ice and snow on the ECON surface.

Adequate bonding between the electrodes and the ECON is critical for achieving satisfactory resistive heating for this system (Chen and Gao 2012, Hou et al. 2007, Tian and Hu 2012). Different types of electrodes for resistive heating, including copper mesh, steel mesh, and perforated galvanized steel bars, have been studied by other researchers (Gopalakrishnan et al. 2015, Wu et al. 2014). In perforated galvanized steel angles, perforations larger than the nominal maximum aggregate size have been suggested because such perforations would help provide satisfactory interlock between the electrode and ECON (Abdualla et al. 2017). Use of angle-shaped electrodes, however, increases crack-formation potential in the concrete pavement due to stress concentration at the angled edge, potentially resulting in durability issues during the pavement lifetime (Abdualla 2018). Corrosion of steel bars has been found to negatively impact temperature increase in an HPS because of weakened electrode-ECON contact (Heymfield et al. 2013). While conductive adhesive on electrodes has also been used to ensure sufficient bonding between the ECON and electrodes, this method was found to have limited cost-effectiveness (Xie and Beaudoin 1995).

3.1.1. Theoretical Background

An ECON HPS relies on resistive heating, also known as Joule heating, by heat generation due to resistivity of a material when exposed to an electric current. In the resistive heating mechanism, electrical energy (E) is converted into thermal energy (Q) (Rao et al. 2019, Malakooti et al. 2021). Steady-state conditions and negligible losses in electrical and thermal performance is assumed here. Given this study is a comparative study under identical environmental conditions, the assumption of negligible losses is a fair assumption. Electrical energy can be calculated by multiplying power (P) by operational time (Δt), as shown in equation 1 (Rao et al. 2018).

$$E = P \cdot \Delta t = \frac{V^2}{R} \cdot \Delta t \quad (1)$$

where V is the applied voltage, and R is the electrical resistance of the material. R can be calculated using resistivity (ρ), a material property normalized by specimen dimensions (Arabzadeh et al. 2019), as shown in equation 2.

$$R = \frac{\rho \cdot L}{A} \quad (2)$$

where L and A are the length and the conductive cross-sectional area in the direction of current flow, respectively. Combining equations 1 and 2, electrical energy can be written as shown in equation 3.

$$E = \frac{V^2 \cdot A}{\rho \cdot L} \cdot \Delta t \quad (3)$$

The thermal energy generated in a material can be calculated from the mass (m), the specific heat capacity (C), and the temperature increase in the material (ΔT) using equation 4 (Sadati et al. 2018).

$$Q = m \cdot C \cdot \Delta T \quad (4)$$

Equation 5 results from equating the electrical energy with the thermal energy ($E = Q$) in equations 3 and 4 and rearranging as follows:

$$\frac{\Delta T}{\Delta t} = \frac{V^2 \cdot A}{\rho \cdot L \cdot m \cdot C} \quad (5)$$

This equation determines the relationship between the temperature increase rate ($\Delta T/\Delta t$) and the specimen dimensions, and the electrical and thermal properties of a material undergoing resistive heating. It shows that the applied voltage has an exponential correlation with the temperature increase rate, while the other properties have a linear correlation.

In addition, voltage and the conductive cross-sectional area have positive correlations, while resistivity, length, mass, and specific heat capacity have negative correlations. Therefore, in order to maximize the temperature increase rate in an ECON HPS, higher applied voltage (V), larger ECON layer thickness with consideration to constant slab dimensions (A), lower ECON resistivity (ρ), and shorter electrode spacing (L) will result in better thermal performance. The conductive cross-sectional area (A) in equation 5 can also be represented as the electrode surface area given the first stage in which electricity is applied to the material is through the surface area of the electrode where the current flows to the material. The temperature increase rate is measured for different electrode sizes and geometries (different surface areas), and thermal and electrical performance is discussed in the following sections.

3.1.2. Methodology

3.1.2.1. Electrode Types for Thermal Performance Evaluation

Stainless steel 316L, a chromium-nickel stainless steel containing molybdenum, was chosen as the electrode material (ASTM A240/A240M 2017). This material is extremely corrosion-resistant, especially to acid sulfates and alkaline chlorides (ASTM A240/A240M 2017), so it would be expected to prolong the performance and durability of the concrete pavement system.

The stainless-steel electrodes used in this study have an electrical resistivity of 29.4 $\mu\Omega$ -in (74.6 $\mu\Omega$ -cm.) at 68°F (20°C) and are capable of conducting an electrical current into the ECON layer (ASTM A66-15 2015). Three different electrode geometries (solid circular, hollow circular, and flat bar) in different sizes were tested. The details of the electrode geometries and their respective unit prices per unit length are shown in Table 2.

Table 2. Selected electrodes with the associated cost

Electrodes	Geometry	Average unit price, USD/ft (USD/m)
0.5 in. (12.7 mm) OD	Smooth solid circular	3.3 (10.7)
0.75 in. (19.0 mm) OD	Smooth solid circular	6.0 (19.6)
1 in. (25.4 mm) OD	Smooth solid circular	10.7 (35.2)
1.5 in. (38.1 mm) OD	Smooth solid circular	28 (91.8)
1 in. (25.4 mm) OD, 0.75 in. (19.0 mm) ID	Hollow circular	9.7 (31.8)
1 in. (25.4 mm) × 3/16 in. (4.7 mm)	Flat bar	3.0 (9.9)

OD = outside diameter; ID = inside diameter
Source: Malakooti et al. 2021

The unit price is based on an average of 10 different market quotes for the same quantities. The unit price of electrodes increases significantly with an increase in electrode diameter, and hollow bars are also 10% cheaper than solid bars of the same diameter. Photographs of the individual electrodes selected are shown in Figure 7.

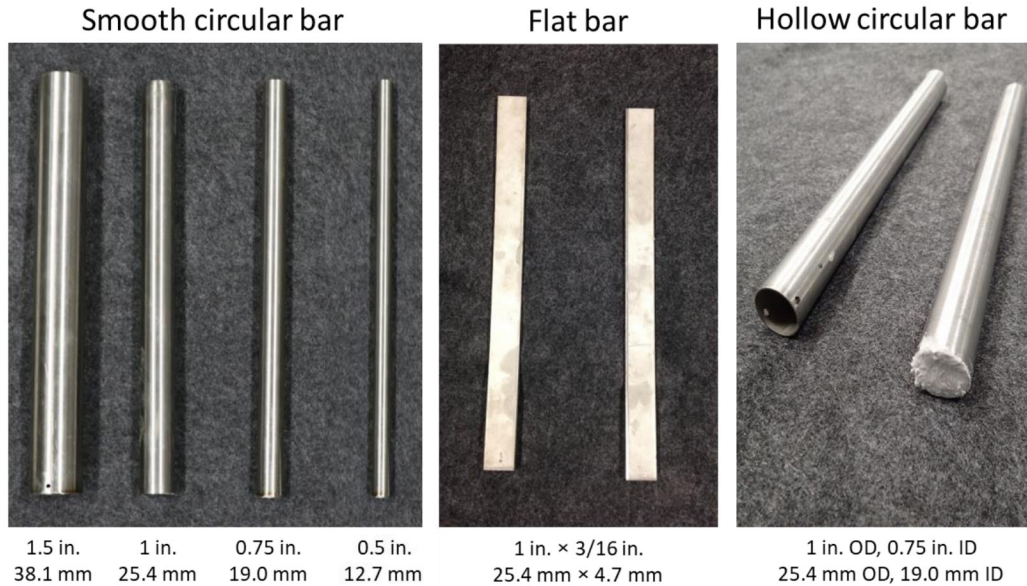

Malakooti et al. 2021, © 2021 Elsevier Ltd. All rights reserved, used with permission

Figure 7. Electrodes used in the study (in. = mm/25.4)

The following sections describe the test setup for thermal performance evaluation of electrodes in water, ECON prototype slab, and the developed finite element (FE) model.

3.1.2.2. Thermal Performance Test Procedure and FE Model of Electrodes in Water

The advantage of testing electrodes in water is that very good electrical contact can be achieved between the water and the electrodes; this is more difficult when testing electrodes embedded in ECON because of air pockets that can occur at the electrode-ECON interface. Testing electrodes in water represents an idealized situation in terms of electrical contact between an electrode and its surrounding matrix. Given water is also homogenous and hence provides virtually uniform heat distribution—while ECON is a heterogeneous material—testing in water, due to its nondestructive nature, represents a rapid, inexpensive, ideal, and cost-effective assessment method for validating hypotheses based on theory.

The water tank used in all tests was 9 in. (229 mm) long, 8 in. (203 mm) deep, and 4 in. (101 mm) wide, as shown in Figure 8a.

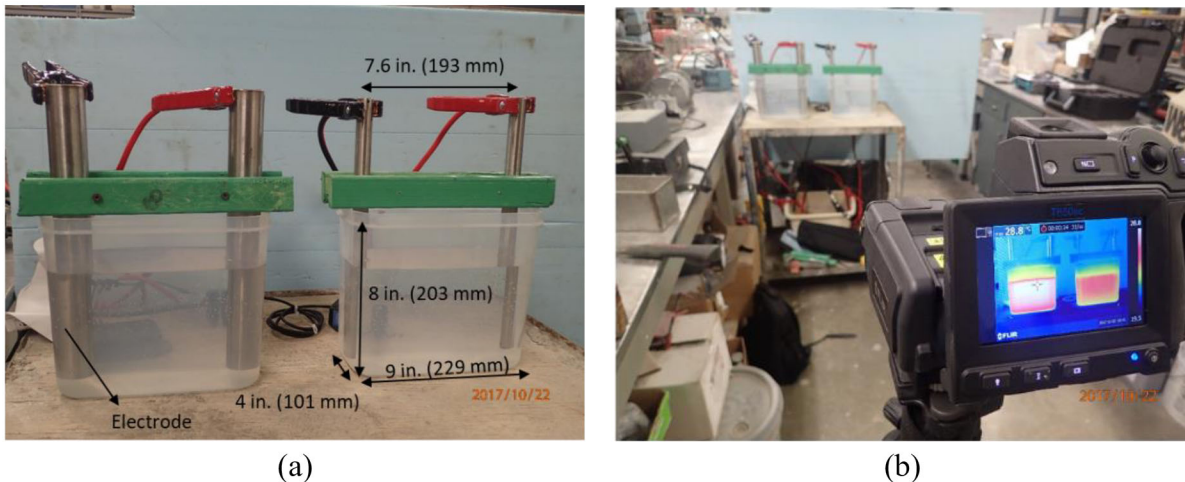

Malakooti et al. 2021, © 2021 Elsevier Ltd. All rights reserved, used with permission

Figure 8. Electrode test in water: (a) tank dimensions and (b) setup

The water used in these tests was tap water with a measured average electrical resistivity of 571 Ω -in. (1,450 Ω -cm), and for each test, an identical amount of water (6.6 lb [3 kg]) was poured into the water tank. The electrodes were placed in the water at least eight hours prior to test initiation to allow both water and electrodes to reach thermal equilibrium at the ambient temperature (68°F [20°C]). A 120 volt alternating current (VAC) was then applied to the electrodes to pass an electric current into the water tank. The temperature and heat generation behavior were monitored using the FLIR T650sc infrared thermal camera shown in Figure 8b, and electrical current was measured using a Southwire TrueRMS clamp meter.

The electrodes were initially tested in water with a 2% (wt.) aqueous solution of sodium chloride, because the electrical conductivity of a sodium chloride solution is higher than that of pure and tap water due to its concentration of charge-carrying ions. However, given using sodium chloride led to sedimentation that resulted in heat concentration visible in the thermographic images at the tank bottom where the sodium chloride had settled (see Figure 9a), it was decided to eliminate the use of sodium chloride to achieve a more uniform temperature

increase within the water tank such that the performance of different electrodes in an ECON matrix could be more accurately simulated (see Figure 9b).

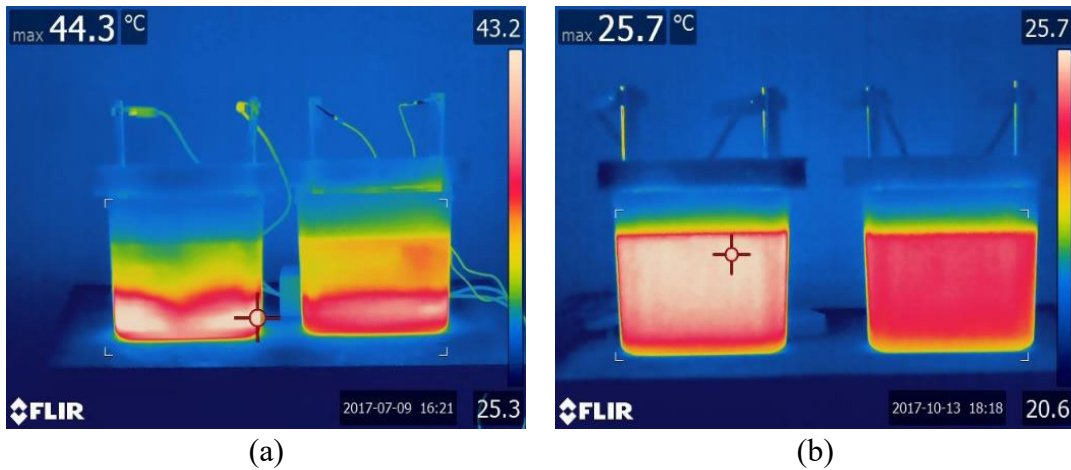

Malakooti et al. 2021, © 2021 Elsevier Ltd. All rights reserved, used with permission

Figure 9. Electrode thermal performance in water: (a) with 2% sodium chloride and (b) without sodium chloride ($^{\circ}\text{F} = [^{\circ}\text{C} \times 1.8] + 32$)

To compare the temperature increase measured in the tests performed in water with theoretical temperature increase values, an FE model of the electrodes in water was developed using ANSYS 2019 simulation software (Alimohammadi and Izadi Babokani 2019, ANSYS, Inc. 2018). The model was developed using eight-node SOLID5 elements capable of modeling resistive heating. The maximum mesh size of 0.4 in. (1 cm) was found by incrementally refining the mesh size until there were no significant changes in the model results. The final meshed model for a pair of 1 in. (25 mm) outside diameter (OD) circular electrodes is shown in Figure 10.

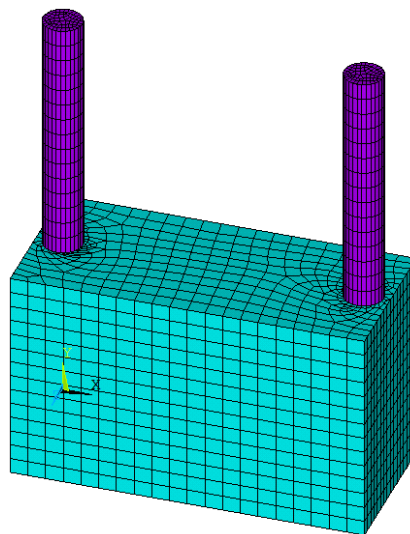

Malakooti et al. 2021, © 2021 Elsevier Ltd. All rights reserved, used with permission

Figure 10. FE model mesh for a pair of 1 in. (25 mm) OD electrodes in water

Given the water container was a thin-walled plastic container, its impact on the temperature increase of the water and the heat transfer between the container wall and the surrounding air were assumed to be negligible. The material properties included in the model were density, heat capacity, electrical conductivity, and thermal conductivity; all except thermal conductivity were measured and used in the model. The thermal conductivity of water was used to calibrate the model. A trial value based on the literature was selected for the thermal conductivity of water, and the value was modified to make the model results match the measurements. This calibration was performed only for the model with the 1 in. (25 mm) OD circular pair of electrodes, and the value obtained for the thermal conductivity of water was used for all other models, i.e., all material properties were the same in all the models.

The material properties for the stainless-steel electrodes were obtained from existing data (Ho and Chu 1977). Figure 11 shows the temperature increase profile and model validation for the 1 in. (25 mm) OD electrodes in the FE model and the experimental data.

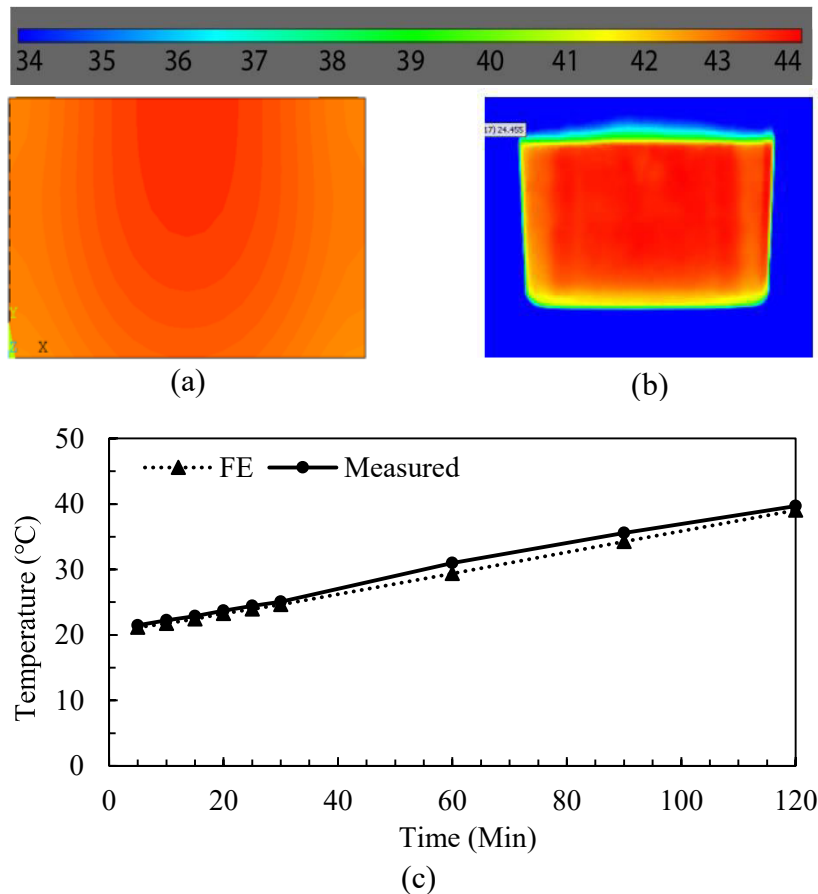

Malakooti et al. 2021, © 2021 Elsevier Ltd. All rights reserved, used with permission

Figure 11. Heat generation profile for 1 in. (25 mm) OD electrodes: (a) FE model, (b) experimental results, and (c) model validation ($^{\circ}\text{F} = [^{\circ}\text{C} \times 1.8] + 32$)

The profile shows a similar temperature increase for both the calibrated FE model and the experimental results. The FE model for the ECON slabs is not included in the scope of this

study, given it was covered in the literature for which the findings also back this current study (Sadati et al. 2019).

3.1.2.3. Thermal Performance Test Procedure of Electrodes in ECON

Five prototype slabs with different electrode geometries and sizes were designed and constructed, all with dimensions of 24 in. (610 mm) × 24 in. (610 mm) with a fixed center-to-center electrode spacing of 18 in. (460 mm). Figure 12 shows the plan and cross-sectional views of the constructed ECON prototype slabs.

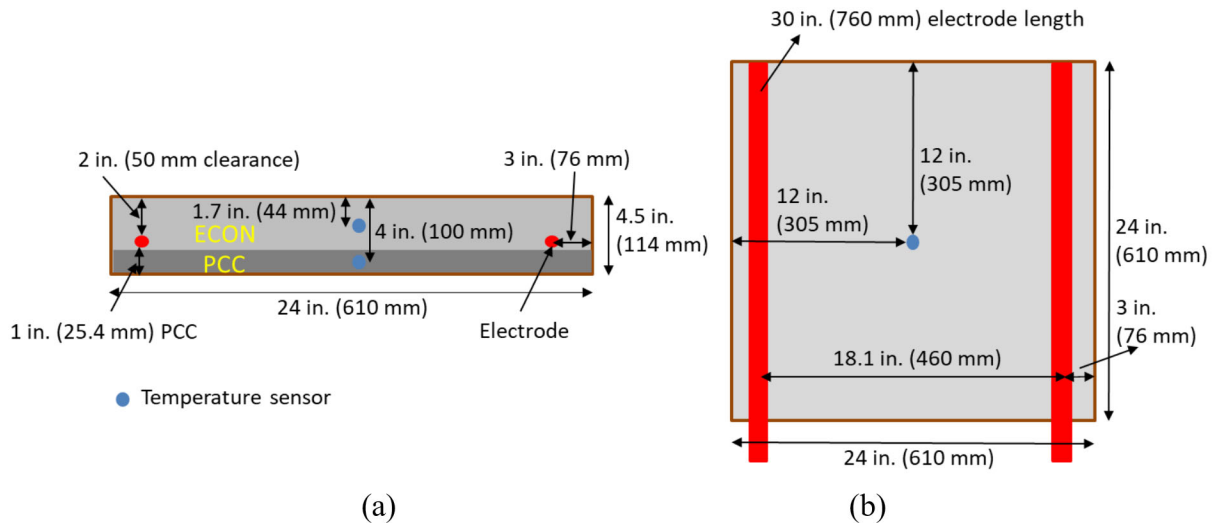

Malakooti et al. 2021, © 2021 Elsevier Ltd. All rights reserved, used with permission

Figure 12. ECON prototype slab dimensions: (a) plan and (b) cross-sectional views

Identical features and parameters in all slabs included electrode spacing (1.5 ft [460 mm]), electrode cover (2 in. [50 mm]), applied testing voltage (60 VAC), and ECON mix design. The electrical resistivity of air-dried normal PCC is typically between $2.57 \times 10^5 \Omega\text{-in.}$ ($6.54 \times 10^5 \Omega\text{-cm}$) and $4.5 \times 10^5 \Omega\text{-in.}$ ($11.4 \times 10^5 \Omega\text{-cm}$) (Malakooti 2017, Mosavi et al. 2020, Whittington et al. 1981), while the average electrical resistivity of the ECON slabs in this study was $23.6 \Omega\text{-in.}$ ($60 \Omega\text{-cm}$) due to the presence of carbon fiber in the mix at 1% by volume.

The two-lift approach used in constructing the ECON prototype slabs (similar to the full-scale field implementation design) consisted of casting a 3.5 in. (89 mm) ECON layer on top of a 1 in. (25 mm) PCC layer. The first underlying reason for this design was to minimize costs, given using only one layer of ECON required less carbon fiber than using two layers of ECON combined with normal PCC of the same thickness. The second reason was to mainly generate heat closer to the surface where snow and ice accumulate. Two-lift paving is similar to retrofitting existing full-scale pavement systems, where the heated pavement would include overlaying ECON on an existing pavement. Figure 13a shows the main steps of constructing the ECON prototype slabs.

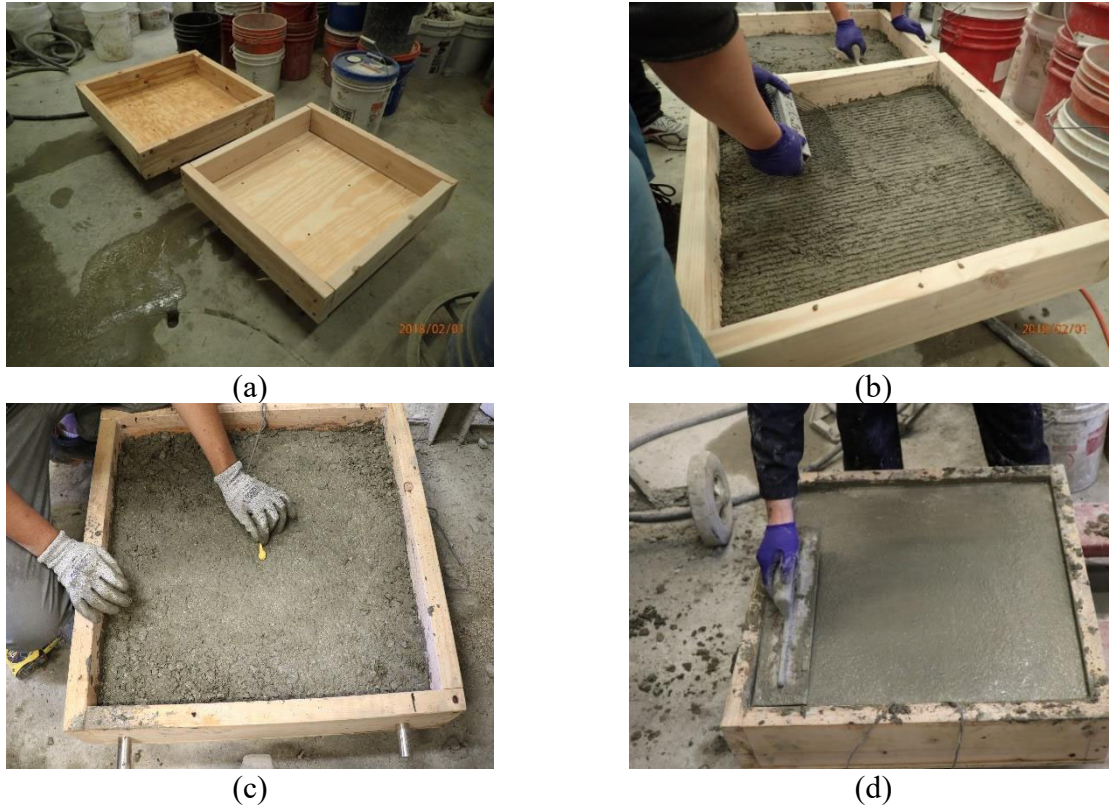

Malakooti et al. 2021, © 2021 Elsevier Ltd. All rights reserved, used with permission

Figure 13. Construction of ECON prototype slabs: (a) fabricate mold, (b) cast normal PCC and roughen surface, (c) place temperature probe, and (d) cast and finish the ECON layer

First, a 1 in. (25 mm) PCC was cast with a temperature sensor placed at its center (4 in. [100 mm] below the slab surface). The PCC surface was then finished and tined, as shown in Figure 13b, to achieve a better bond between the standard concrete and the ECON layer. In the second step, a 3.5 in. (89 mm) thick ECON layer was placed on top of the hardened PCC layer, with sensors placed in the middle of the ECON layer 1.7 in. (44 mm) below the slab surface (Figure 13c). Consolidation was performed using a probe vibrator. The finished surface is depicted in Figure 13d.

While the 1 in. (25 mm) normal PCC layer for all tested slabs was constructed and cast at one time, the ECON layers were cast on separate days using the same process. The reason for this approach was to improve the uniformity of carbon fiber dispersion in the ECON mix by mixing in small batches. For larger batches, the mixing power of the drum mixer would have been insufficient to achieve better fiber dispersal within the concrete mixture. All slabs were wet-cured after casting for eight days using wet rags and were tested at the same age (eight days). The ECON mixing proportions used for casting the slabs are given in Table 3.

Table 3. ECON mix proportions

Components		Type	Content, kg/m ³ (lb/yd ³)
Basic	Coarse aggregate (3/4 in. [19 mm])	Limestone	1021 (606)
	Intermediate aggregate (3/8 in. [9.5 mm])	Limestone	510 (303)
	Fine aggregate	River sand	1163 (690)
	Fly ash	Class C	165 (98)
	Cement	Holcim Type I/II	654 (388)
	Water	Tap water	297 (176)
Admixtures	Derex Corrosion Inhibitor (DCI)	W. R. Grace & Co. DCI	44 (26)
	Air-entraining agent (designed for 6% air)	MasterAir AE 90	1 oz/cwt (29.6 ml/cwt)
	High-range water reducer (HRWR)	MasterGlenium 7500	0.5% wt. cem.
	Viscosity-modifying admixture	VMA	80 oz/yd ³ (3100 ml/m ³)
	Carbon fiber, 0.25 in. [6 mm]	Synthetic carbon fiber	0.97 (% vol.)

cwt = hundredweight of cementitious materials

Source: Malakooti et al. 2021

This mix design is based on previous studies (Sassani et al. 2017, 2018b), with the one difference being the inclusion of a viscosity-modifying admixture (VMA) to increase the mix viscosity for improvement of ECON finishing while decreasing the possibility of segregation.

3.1.3. Results

The following section presents the results from the water, ECON prototype slab, and FE modeling.

3.1.3.1. Water Test Thermal Performance and FE Model Results

Examples of thermal images taken during the electrode test in water are shown in Figure 14a.

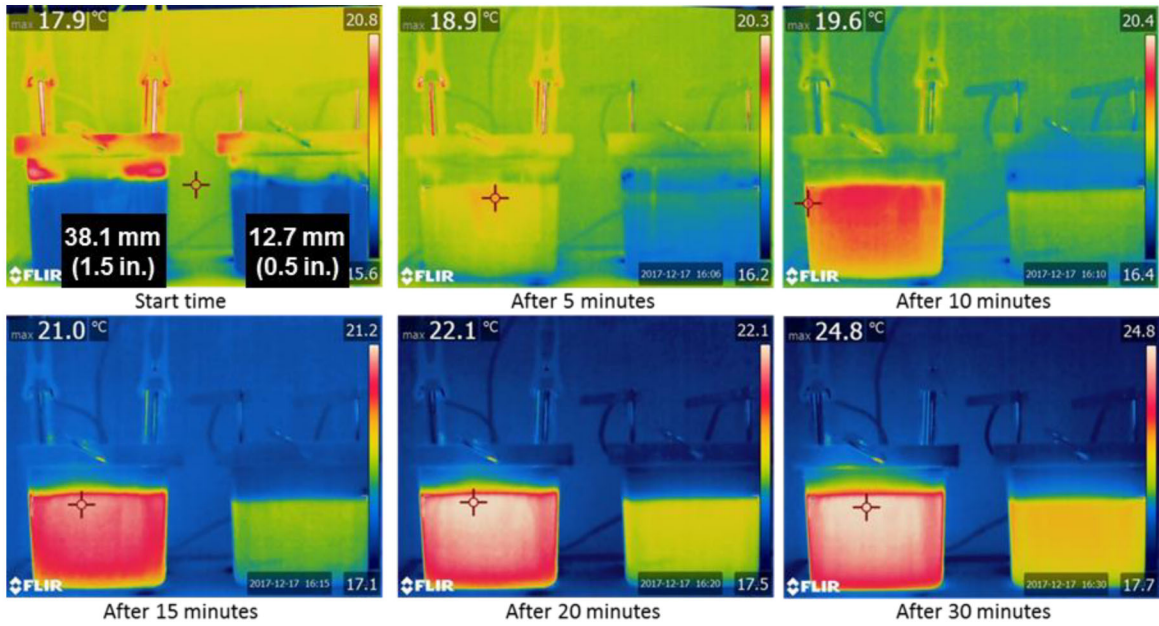

(a)

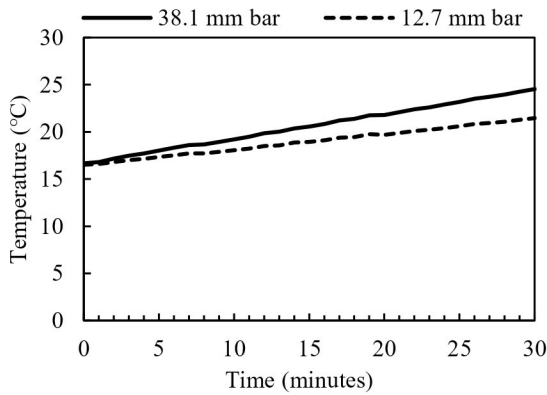

(b)

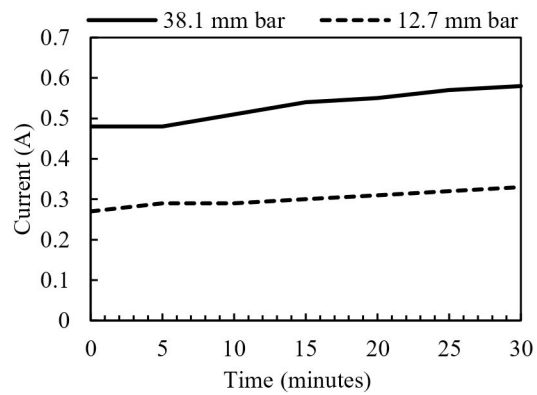

(c)

Malakooti et al. 2021, © 2021 Elsevier Ltd. All rights reserved, used with permission

Figure 14. Electrode test in water: (a) thermography imaging, (b) temperature versus time plot, and (c) current versus time plot (in. = mm/25.4, °F = [°C × 1.8] + 32)

These images, captured at five-minute intervals, represent the performance of a 1.5 in. (38.1 mm) OD electrode (left) and a 0.5 in. (12.7 mm) OD electrode (right). The average surface temperatures of both water tanks were measured and are plotted in Figure 14b. The current readings during this test, taken every five minutes, is also shown in Figure 14c. Based on these figures, the temperature increase rate of the 1.5 in. (38.1 mm) OD electrode was higher than the 0.5 in. (12.7 mm) OD because of the larger surface contact area of this electrode with the water.

The temperature increase rate shows how quickly each electrode can generate heat and eventually, when used in an ECON HPS, melt ice and snow. It is essential to know how quickly the surface temperature of an ECON HPS rises above the freezing point (41°F [5°C]) to start the melting process. The temperature increase curve was found to be linear even when tested for

hourly durations, but it eventually reached a plateau because of the limitation of water ion availability. The current was also found to increase linearly, with larger electrodes exhibiting higher current values than smaller electrodes. Current is an important parameter in designing an ECON HPS system, given it directly impacts the power demand requirements for slab heating that also impacts operational costs. Temperature increase for all electrodes, similar to the one shown in Figure 14b, was found to be linear with respect to the amount of time in the water. Thus, the rates of temperature increase, i.e., the slopes of the plots of temperature versus time, were calculated and compared to determine both the most and least favorable electrodes in terms of the rate of temperature increase. Figure 15 shows the temperature increase rate for each electrode type obtained from the experimental tests and the FE models.

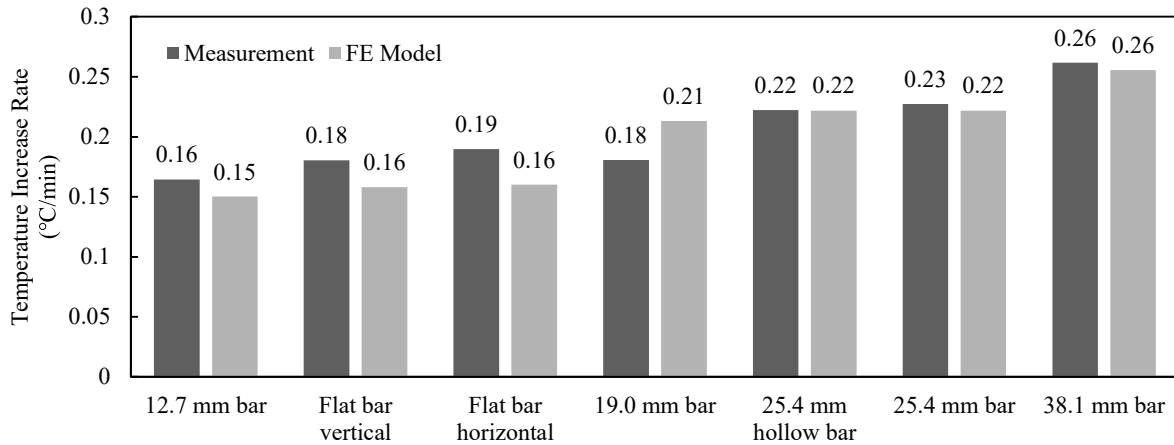

Malakooti et al. 2021, © 2021 Elsevier Ltd. All rights reserved, used with permission

Figure 15. Temperature increase rate for electrodes in water ($^{\circ}\text{F} = [^{\circ}\text{C} \times 1.8] + 32$)

The 1.5 in. (38.1 mm) OD smooth stainless-steel bar achieved the highest temperature increase, about 0.47°F (0.26°C) per minute, while the 0.5 in. (12.7 mm) OD electrode had the lowest rate among the electrodes tested. It should be noted that the greater heat generated by larger electrode sizes can be attributed to the larger contact area with the water that allows a greater amount of electric current to pass through. Note that in the case of the hollow bars, given the ends were blocked to ensure that contact between electrode and water occurred only on the outer surface of the electrodes, similar heat performance was observed between a 1 in. (25.4 mm) OD hollow electrode with blocked ends and a 1 in. (25.4 mm) OD solid electrode (same surface area).

These findings can help in the future design of more efficient HPSs using ECON, given hollow bars are less expensive and easier to transport. The results of the thermal performance tests also showed that changing the orientation of the same flat bar in the water tank (vertically and horizontally) produced no significant change in the rate of temperature increase. As shown in Figure 15, the temperature increase obtained by the FE model follows a similar trend to that of the experimental tests and the theory considered.

3.1.3.2. ECON Prototype Slab Thermal Performance Results

ECON prototype slab tests with an embedded 1 in. (25.4 mm) × 0.2 in. (5 mm) flat bar and an embedded 1 in. (25.4 mm) OD smooth solid circular bar are shown in Figure 16.

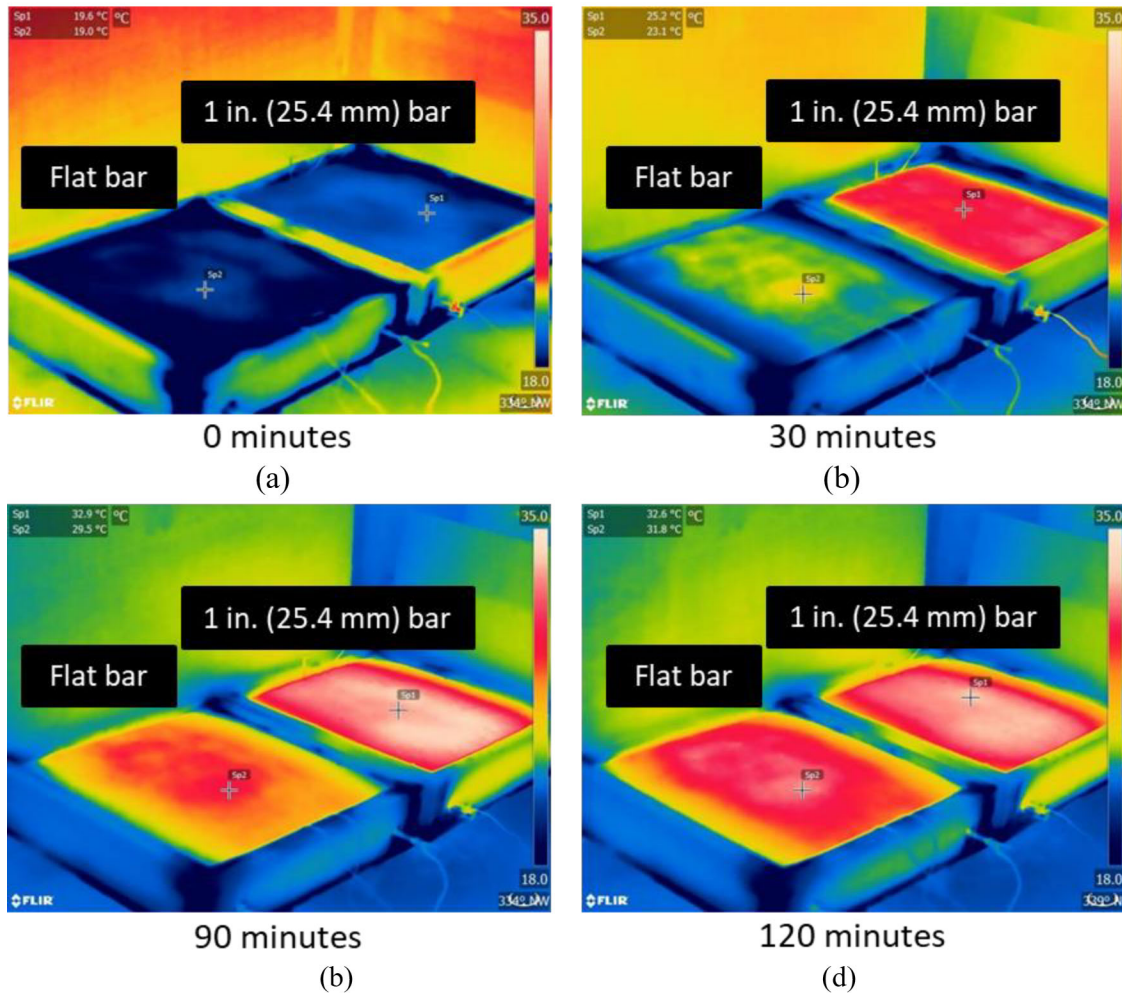

Malakooti et al. 2021, © 2021 Elsevier Ltd. All rights reserved, used with permission

Figure 16. Thermographic imaging for sample ECON prototype slabs: at (a) initial condition, (b) 30 minutes, (c) 90 minutes, and (d) 120 minutes ($^{\circ}\text{F} = [^{\circ}\text{C} \times 1.8] + 32$)

The left ECON slab represents the flat bar prototype slab, and the right slab represents a prototype slab with a 1 in. (25.4 mm) OD smooth electrode. Figure 16a shows the initial condition of the two slabs. Over time, the slab with the 1 in. (25.4 mm) OD smooth electrode exhibited a more rapid temperature increase than the slab with the flat bar (Figure 16b, Figure 16c, and Figure 16d). Figure 17a depicts the average surface temperature over time for the ECON prototype slabs.

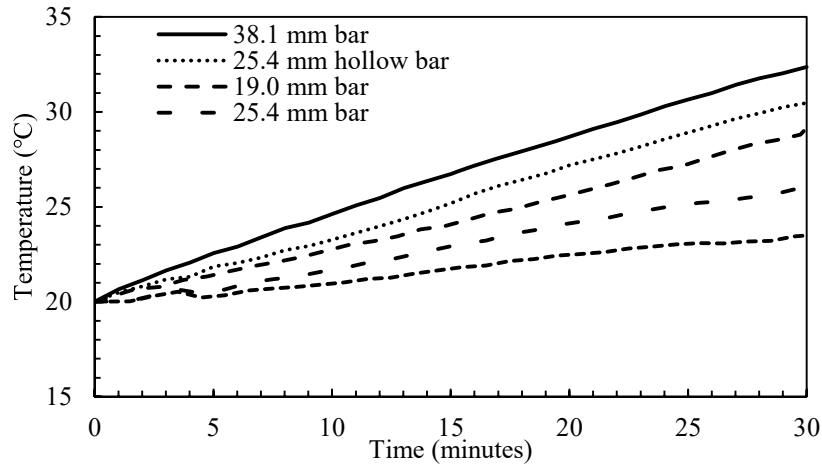

(a)

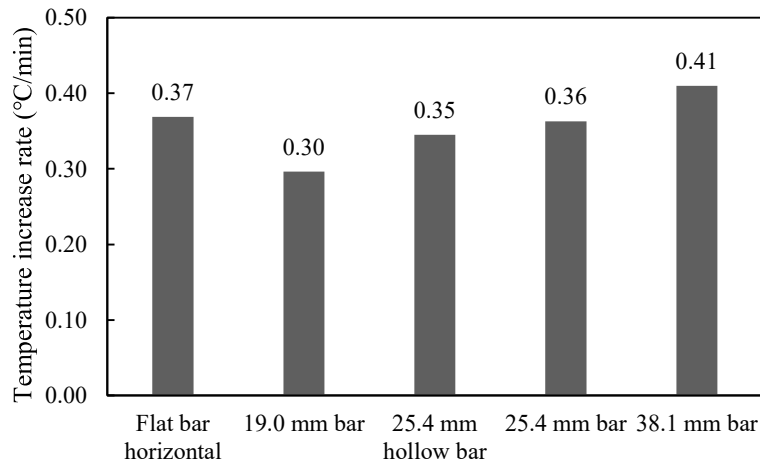

(b)

Malakooti et al. 2021, © 2021 Elsevier Ltd. All rights reserved, used with permission

Figure 17. ECON prototype slab results: (a) average surface temperature versus time and (b) corrected temperature increase per minute for electrodes (in. = mm/25.4, °F = [°C × 1.8] + 32)

The slope of the temperature versus time curve is plotted in Figure 17b. The greater the slope, the greater the temperature increase rate associated with a specific electrode. The results show that a 1.5 in. (38.1 mm) OD smooth electrode provided the highest temperature increase rate among all the electrodes tested, in agreement with the electrode tests in the water, the FE model, and the theory.

The current remained nearly constant during all test periods. Table 4 shows the average measured current and the resistivity for each individual ECON prototype slab.

Table 4. Current and resistivity of ECON prototype slabs

ECON Prototype	Embedded electrode	Current, A	Resistivity, Ω -in. (Ω -cm)
1	Flat bar (1 in. [25.4 mm] \times 3/16 in. [4.7 mm])	4.50	46.7 (118.5)
2	0.75 in. (19.0 mm) OD smooth solid circular bar	13.36	15.7 (39.9)
3	1 in. (25.4 mm) OD smooth solid circular bar	8.29	25.3 (64.3)
4	1 in. (25.4 mm) OD hollow circular bar	13.10	16.0(40.7)
5	1.5 in. (38.1 mm) OD smooth solid circular bar	13.76	15.3 (38.8)

Source: Malakooti et al. 2021

Despite similarities between the water tank and ECON experiments with respect to identifying the best-performing electrode, there were some discrepancies in terms of ranking of the electrodes' thermal performance. The performance ranking results from the slab tests for the flat bar and the 1 in. (25.4 mm) OD solid bar differed from those from the water test. This can be ascribed to the higher resistivity of the concrete in these slabs (see Table 4) compared to the other slabs due to the nonhomogeneous nature of the ECON layer. These two slabs, therefore, exhibited poorer performance given their higher resistivity will resist current and result in a lower rate of temperature increase (equation 5). Consequently, an adjustment to the temperature increase rate was necessary to eliminate the effect of resistivity in electrode heating performance for these two slabs. Given the temperature increase rate has a linear inverse correlation with resistivity (Sadati et al. 2018), the temperature increase rate for the two slabs with higher resistivities was adjusted by their respective resistivity values, as shown in Figure 17b.

The temperature increase rate for both the water and the ECON prototype slab tests is plotted against the perimeter of each electrode (Figure 18), clearly showing the correlation between the perimeter (electrode surface contact area) and the temperature increase rate.

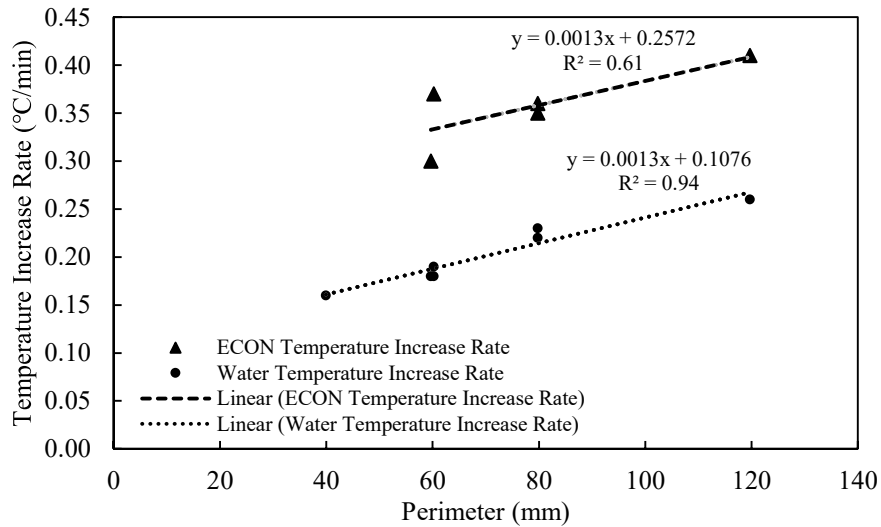

Malakooti et al. 2021, © 2021 Elsevier Ltd. All rights reserved, used with permission

Figure 18. Temperature increase rate vs. perimeter for water and ECON tests (in. = mm/25.4, °F = [°C \times 1.8] + 32)

The slope of the perimeter versus the temperature increase rate curve was found to be identical for the water and the ECON prototype slab tests. This is an important finding that can help future researchers, supporting the notion that water can be used for testing thermal performance as an easier, less expensive, and nondestructive test method. The theory also showed that the electrode surface contact area has a positive linear correlation, a similar result to the experimental and FE model findings in both water and ECON prototype slabs.

3.1.4. Discussion of Practical Implications

3.1.4.1. Energy Conversion Efficiency

In resistive heating, not all the electrical energy is converted to thermal energy, and the energy conversion efficiency (EF) is the efficiency of converting electrical energy (E) into thermal energy (Q), and thereby, energy conversion efficiency can be calculated using equation 6.

$$EF (\%) = \frac{Q}{E} \times 100 \quad (6)$$

Given both the thermal and electrical performance of the ECON prototype slabs were monitored during this study, both can be calculated. The electrical energy is calculated using equation 1, and thermal energy is calculated based on the thermal performance curves (see previous Figure 17a) and equation 4. Energy consumption and energy conversion efficiency calculations for all the ECON prototype slabs are given in Table 5.

Table 5. Energy conversion efficiency calculation for ECON prototype slabs ($\text{kW}/\text{ft}^2 = \text{kW}/\text{m}^2 \div 10.764$)

Energy consumption									
Electrode type	Voltage (VAC)	Current (A)	Power (kW)	Power density (kW/m^2)	Test duration (h)	Total energy density (kWh/m^2)	Input electrical energy (kJ)	Energy converted to heat (kJ)	Energy conversion efficiency in ECON (%)
Flat bar	60	4.50	0.27	0.96	0.50	0.48	486	269	55
0.75 in. (19.0 mm) OD bar	60	13.36	0.80	2.86	0.50	1.43	1,443	704	49
1 in. (25.4 mm) OD solid bar	60	8.29	0.50	1.78	0.50	0.89	895	467	52
1 in. (25.4 mm) OD hollow bar	60	13.10	0.79	2.81	0.50	1.40	1,415	805	57
1.5 in. (38.1 mm) OD bar	60	13.76	0.83	2.95	0.50	1.47	1,486	951	64

Source: Malakooti et al. 2021

Based on these calculations, among the electrodes tested, the 1.5 in. (38.1 mm) OD bar exhibited the highest energy conversion efficiency, and the 0.75 in. (19.0 mm) OD bar the lowest. These results show that conversion efficiency is increased by increasing electrode size (electrode surface contact area) in the ECON prototype slab. The average energy conversion efficiency calculated based on this study was found to be 55.4%.

3.1.4.2. Cost Analysis

The cost analysis in this section focuses only on the cost of electrodes, one component of an ECON HPS, while also considering thermal performance of different electrodes. The bar plots shown in Figure 19 of the temperature increase rate were taken from the water (see previous Figure 15) and ECON prototype tests (see previous Figure 17b) and normalized by the average initial cost of each electrode (see previous Table 2).

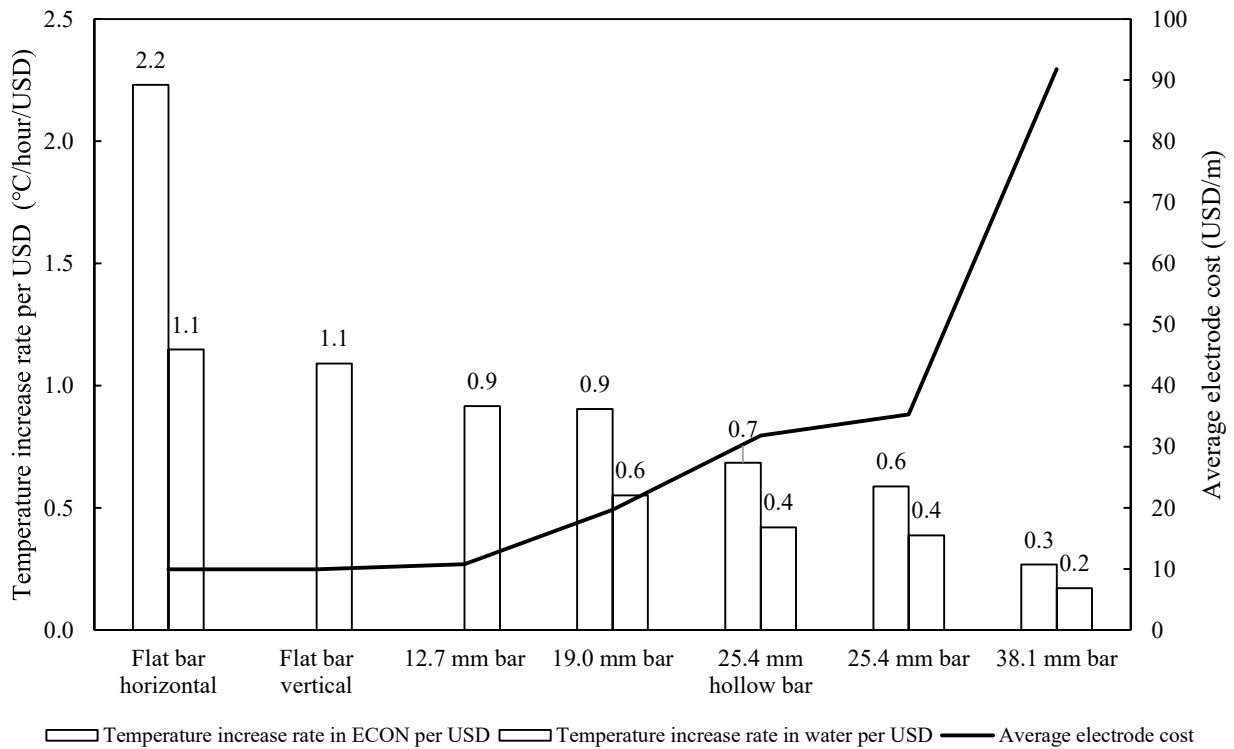

Malakooti et al. 2021, © 2021 Elsevier Ltd. All rights reserved, used with permission

Figure 19. Temperature increase rate per average initial cost of electrode (ft = m×3.281, in. = mm/25.4, °F = [°C × 1.8] + 32)

This figure depicts the initial cost-effectiveness of each electrode, considering the temperature increase rate capacity, with a higher value corresponding to greater cost-effectiveness of that electrode. From this cost analysis, the flat bar was found to be the most cost-effective, and the 1.5 in. (38.1 mm) OD solid bar the least cost-effective electrode, with electrode cost-effectiveness decreasing with an increase in electrode size due to the higher cost of the larger-size electrodes relative to the temperature increase rate each can provide. This pattern was found

to be similar for both water and ECON prototype slab tests. The average electrode cost of each electrode is also plotted in the secondary vertical axis.

It is essential to note that the speed of ice and snow melting is important, and while larger diameter electrodes can provide more heat more quickly than smaller electrodes, they may not be as cost-effective, and larger electrodes also have slightly greater energy conversion efficiency. This issue would be more critical in locations such as airports or critical infrastructure requiring faster snow/ice clearing. This means that in choosing an electrode for ECON HPS design, the speed of temperature increase and cost-effectiveness of the electrode type should both be taken into consideration, so it is best when designing ECON HPSs for these types of infrastructure systems to continue using the most cost-effective electrode but at a higher voltage to achieve faster snow and ice melting.

3.2. Energy Requirements for Snow Melting in Ames, Iowa

Based on the methodology provided by the American Society of Heating, Refrigerating and Air-Conditioning Engineers (ASHRAE) handbook section on snow melting and freeze protection (ASHRAE 2009), the heat flux requirement for heated pavements at Ames, Iowa, were calculated. These calculations were based on the weather conditions. Weather conditions for Ames, Iowa, were downloaded from available data through the Iowa Environmental Mesonet website (IEM 2019). These weather data included air temperature, wind speed, snow precipitation rate, and dew point temperature. Figure 20 shows the resulting required heat flux for melting snow considering the snow events in Ames, Iowa, from 1996 to 2019.

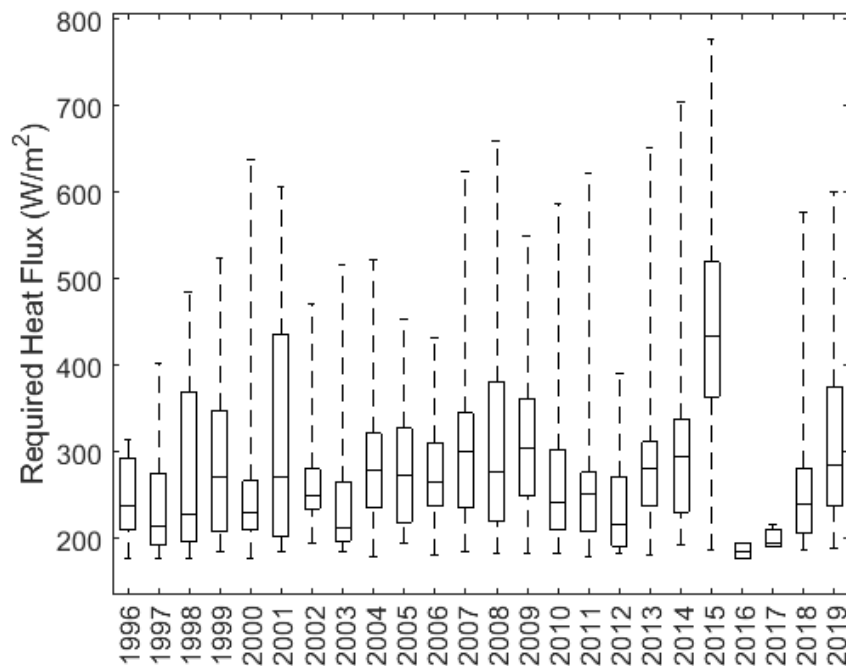

Figure 20. Required heat flux for snow events at Ames, Iowa, from 1996 to 2019 ($W/ft^2 = W/m^2 \div 10.76$)

The median of the required heat flux is less than 27.9 W/ft² (300 W/m²) for all these years except 2015. Therefore, the Iowa State University (ISU) team targeted a heat flux of 27.9 W/ft² (300 W/m²) to 37.2 W/ft² (400 W/m²) for the ECON HPS developed for this project.

It should be noted that more than 70% of the snow events in Ames, Iowa, occurred in temperatures higher than 23°F [-5°C] (see Figure 21). The snow events occurring in colder temperatures would require a higher energy for snow melting.

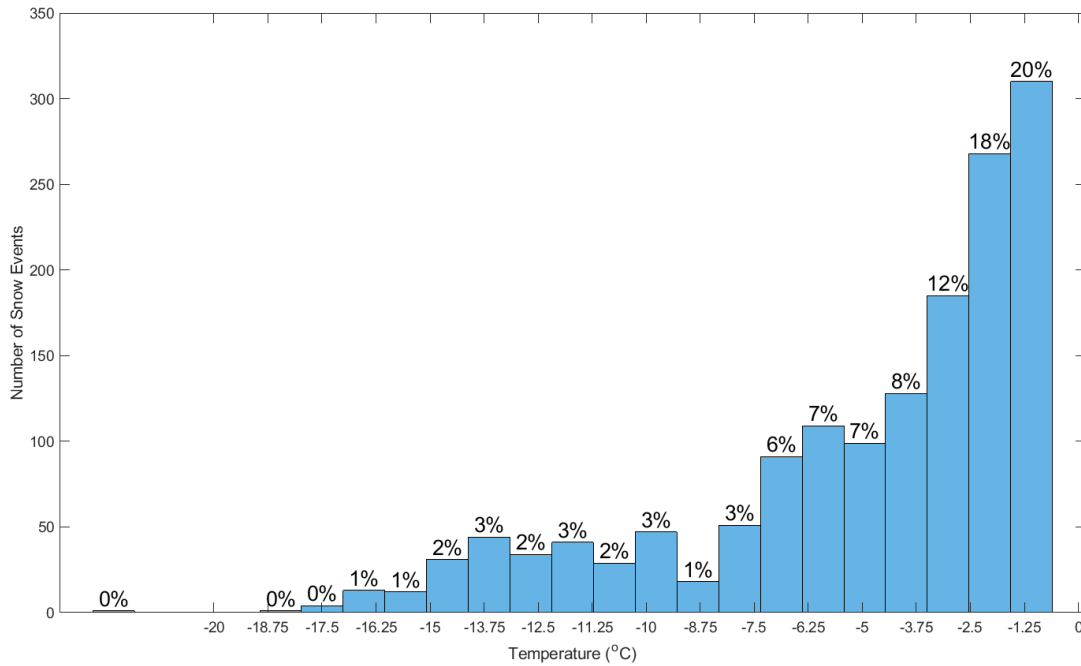

Figure 21. Snow event histogram in Ames, Iowa, in different temperatures (°F = [°C × 1.8] + 32)

4. DESCRIPTION OF SYSTEM DESIGN ELEMENTS

This chapter compares and contrasts system design elements between two ECON HPSs that were constructed, one at the general aviation area at the DSM and 10 ECON HPS slabs at the south parking lot entrance of the Iowa DOT headquarters in Ames, Iowa. The draft standard specification for the Iowa DOT project can be seen in Appendix A.

Table 6 shows the slabs dimensions, thicknesses, and construction time for both locations. The Iowa DOT construction was five times larger than the DSM project, and this led to construction difficulties that are explained in Chapter 5.

Table 6. DSM and Iowa DOT concrete pavement system information

Items	DSM	Iowa DOT
Slab dimensions	12.5 ft (3.8 m) × 15 ft (4.6 m)	12 ft (3.6 m) × 15 ft (4.6 m)
Number of slabs	2	10
ECON thickness	3.5 in. (8.9 cm)	7.6 cm (3 in.)
PCC thickness	4 in. (10.1 cm)	7 in. (17.8 cm)
Electrode type	Angle	Circular and flat bar
Electrode spacing	36 in. (91.4 cm)	20 in. (50.8 cm), 25.5 in. (64.8 cm), and 36 in. (91.4 cm)
Construction time	November 2016	October 2018

4.1. ECON Mix Design

The ECON mix design was similar to standard PCC mix design with carbon fiber added as a conductive agent. Table 7 gives a side-by-side comparison of the DSM and Iowa DOT ECON mix proportions.

Note that Table 7 information was gathered through experimental studies conducted during numerous laboratory investigations before it was chosen to be used in the field investigation (Abdualla et al. 2018; Malakooti et al. 2020; Sassani et al. 2017, 2018b).

The water/cementitious materials ratio for both mixes was set to 0.42, and aggregate gradation and proportion were similar for both mixes. The research team encountered loss of workability (flash set) during construction at the DSM because of both the long distance from the concrete plant to the construction site and incompatibility between some of the admixtures used. It was, therefore, decided to use 20% fly ash Class C replacement by weight for the Iowa DOT project and to eliminate methylcellulose and DCI admixtures from the ECON mix to solve the flash set problem, resulting in an ECON slump of 4 in. (10 cm). The carbon fiber content also increased from 1% to 1.25% because of the elimination of the fiber-dispersive agent (methylcellulose), reducing the risks of poor carbon fiber dispersion within the mix and insufficient carbon fiber at every location. This elimination also helped simplify the ECON mix design and make it easier to reproduce at any ready mixed concrete plant.

Table 7. ECON mix proportions for DSM and Iowa DOT projects

Components		Type	DSM lb/yd ³ (Kg/m ³)	Iowa DOT lb/yd ³ (Kg/m ³)
Basic	Coarse aggregate	0.75 in. (1.9 cm) concrete stone	1,001 (594)	986 (585)
	Intermediate aggregate	3/8 in. (0.95 cm) chips	499 (296)	507 (301)
	Fine aggregate	Concrete sand	1,134 (673)	1078 (640)
	Cement	Holcim type I/II	800 (475)	634 (376)
	Fly ash	Class C	--	163 (97)
	Water	Potable water	337 (200)	337 (200)
	Carbon fiber, 0.25 in. (0.64 cm)	Synthetic carbon fiber	1.00 (% vol.)	1.25 (% vol.)
Admixtures	Air entrainment	EUCON AEA-92	--	3 oz/cwt (89 ml/cwt)
	Water reducer	EUCON WR 91	--	7.5 oz/cwt (222 ml/cwt)
	Methylcellulose	Fiber dispersive agent	1.6 (0.95)	--
	DCI admixture	Corrosion inhibitor and conductivity agent	42.1 (25)	--

Sources: Abdulla et al. 2018; Malakooti et al. 2020; Sassani et al. 2017, 2018b

4.2. Voltage Selection

The applied voltage is directly correlated with snow/ice melting speed and the power consumption of the ECON HPS, i.e., the higher the voltage, the faster the snow melting and the higher the power consumed.

While the DSM project can only operate at 208 VAC, the Iowa DOT project can be operated using either 120 or 208 VAC. This flexibility of using two different voltages provides the ability to adjust the speed of melting to meet specific needs. For example, snow events started during busy weekdays can use 208 VAC, while snow precipitating during a weekend can be managed using 120 VAC.

4.3. Control System Design

The ECON HPS control system turns the system on and off using electrical switches. Arduino board microcontrollers were used in the DSM project, which are low-cost and easy-to-program control systems (Sadati et al. 2020b). Conversely, the disadvantage of the Arduino controller was that it required connection to a computer to control turning it on and off using its software, and it was also not capable of automatic system turn on/off based on pavement surface temperature to save energy. Therefore, a programmable logic controller (PLC) was chosen as the standard

control system for the Iowa DOT project, because it did not require an additional user laptop given it had onboard memory, central processing unit (CPU), and communication modules connected to the internet, allowing remote control. The expandable PLC system gave the user the flexibility in adding more modules and more slab control without additional cost.

A PLC also provides the capability for monitoring and controlling slab surface temperature using relays (switches) and different voltages (120 and 208 VAC) to affect the speed of snow and ice melting on the surface.

A recommendation for future control system design for ECON HPS projects would be to embed thermocouples within the ECON slabs and connect them to PLC analog temperature input modules, enabling the control system to continually monitor the temperature within the slabs (T_{slab}). When the ambient temperature drops, T_{slab} will decrease as well, and once this temperature has dropped below a predetermined temperature (T_{sys_on}), the control system will signal the relays to connect the ECON HPS to a 120 VAC power source, turning the system on and generating heat. If the temperature continues to drop below a specified threshold temperature (T_{thres}), the system will automatically switch to 208 VAC instead to generate more heat for efficiently melting the snow and ice on top of the slabs, thereby maintaining a surface temperature that discourages snow or ice buildup. After the ambient temperature has risen back above the freezing point, or T_{sys_on} , the system will turn off to save energy and eliminate overheating. In summary, the system will use higher voltage (208 VAC) if the weather condition is harsh and uses lower voltage (120 VAC) to maintain its temperature.

Figure 22 shows the flowchart of the procedures used by the control system.

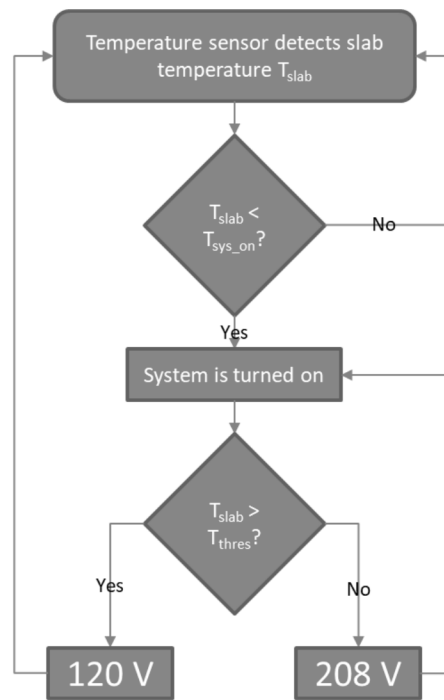

Figure 22. Control system flowchart to determine applied voltage

4.4. Electrode Configuration Design

4.4.1. Electrode Type

As previously shown in Table 6, the DSM project was constructed only with stainless-steel angle electrodes with fixed spacing, while the Iowa DOT project used various types of stainless-steel electrodes and spacings for 10 test slabs. Given the sharp edges of the angle electrodes produce stress concentration, creating a potential for cracking during the service life of the pavement, the research team decided to reinforce the DSM ECON structure with perpendicular fiberglass bars to eliminate this cracking potential (see Figure 23a). However, given that circular (i.e., smooth solid circular and hollow circular) and flat bar electrode shapes were chosen for the Iowa DOT project, their shape eliminated premature cracking and the need for fiberglass reinforcement during construction to save cost and time (see Figure 23b).



(a)



(b)

Figure 23. Electrode setup: (a) perpendicularly reinforced with fiberglass bar at DSM and (b) without fiberglass bar reinforcement at Iowa DOT

4.4.2. Numerical Analysis for Electrode Configuration Options

A numerical analysis was conducted by using an FE model to evaluate and identify electrode configuration options of each test slab (i.e., 10 test slabs in total) before the construction of the Iowa DOT project. The physical phenomenon underlying the heating process used in an ECON HPS is Joule heating (Sadati et al. 2018) based on a voltage gradient between the two ends of a conductive material. Assuming constant resistance (R), the higher the voltage gradient (V), the higher the power of heat generation (P), as reflected by equation 7.

$$P = \frac{V^2}{R} \quad (7)$$

Figure 24 depicts the constant voltage lines for the three different studied electrode shapes.

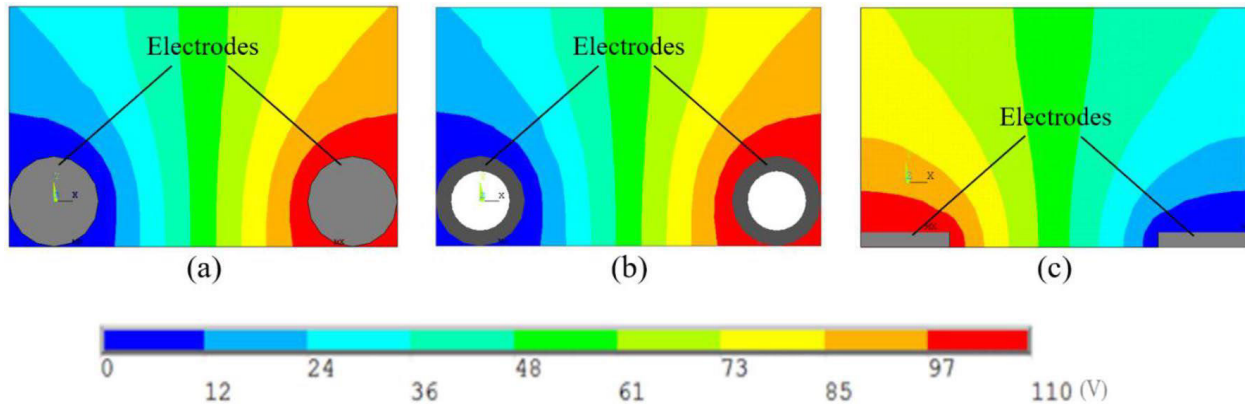
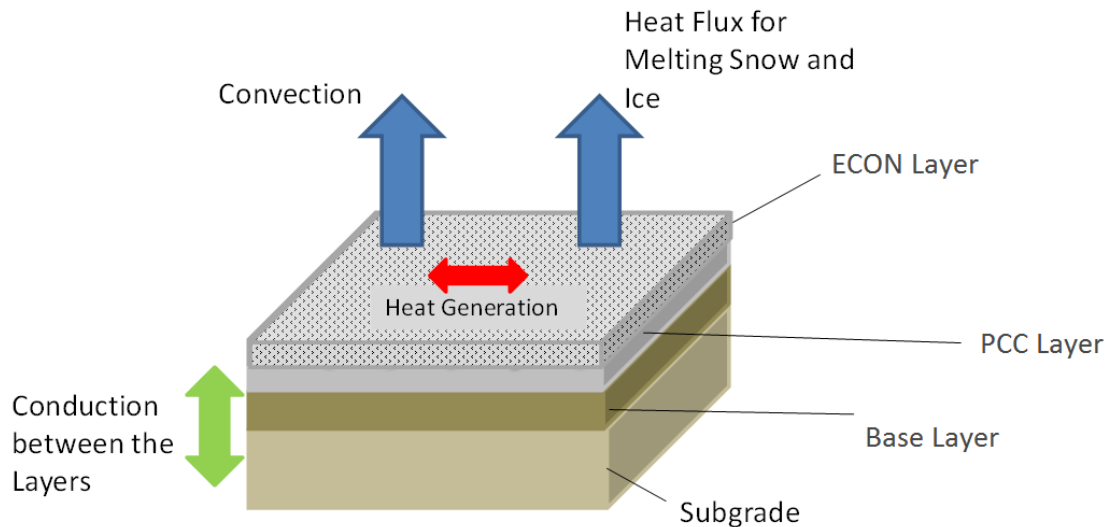

Figure 24. Voltage lines developed by different electrodes: (a) smooth solid circular bar, (b) hollow circular bar, and (c) flat bar

The distribution of these lines depends on the geometry of the concrete material and electrodes and the distance between the two electrodes. The closer the outer surfaces of the electrodes, the higher the voltage gradient in the material.

An FE model was developed in ANSYS (ANSYS, Inc. 2018) and validated with experimental data, as described in studies by Sadati et al. (2017, 2018), and the modeled loads and boundary conditions used are shown in Figure 25.



Sadati et al. 2020a, © 2020 Springer Ltd. All rights reserved., used with permission

Figure 25. FE model developed to simulate all pavement layers and the interaction between the surface and the environment

ECON HPS heating is based on a Joule heating (or resistive heating) process, and the governing equations for this process are (Liu 2017) as follows:

$$E = -\nabla\phi, \quad (8a)$$

$$J = \frac{1}{\rho}E, \quad (8b)$$

$$\nabla \cdot J = 0, \quad (8c)$$

where E is electric field (V/in.), ϕ is the electric potential (V), J is the electric current density (A/in.²), and ρ is the electrical resistivity (Ω -in.). Transit thermal analysis for simulating the heating process that produces temperature variation by time is based on the following equations (Liu 2017):

$$q'' = -k\nabla T \quad (9a)$$

$$k\nabla^2 T + \dot{q} = \beta C_p \frac{\partial T}{\partial t} \quad (9b)$$

$$\dot{q} = \rho |J|^2, \quad (9c)$$

where q'' is the heat flux (W/in.²), k is the thermal conductivity (W/in.²°F), T is the temperature (°F), \dot{q} is the heat generation by Joule heating (W/in.³), β is the mass density (lb/in.³), C_p is the specific heat (J/lb°F), and t is time (s).

In the FE model, given that the temperature (T) varies in both space and time (ANSYS, Inc. 2018), the temperature at each node is considered to be dependent on time, and T can be calculated by multiplying element shape functions to the nodal temperature vectors of equation 10, given as follows:

$$T = \{N\}^T \{T_n\} \quad (10)$$

where $\{N\}$ is a space-dependent element shape function vector and $\{T_n\}$ is the time-dependent nodal temperature vector.

For a transient solution, given variation of T with time is sought for applied voltage assumed to be constant, the FE equation for this problem can be written as follows:

$$\begin{bmatrix} C & 0 \\ 0 & 0 \end{bmatrix} \begin{bmatrix} \dot{T} \\ \dot{\phi} \end{bmatrix} + \begin{bmatrix} K^t & 0 \\ 0 & K^e \end{bmatrix} \begin{bmatrix} T \\ \phi \end{bmatrix} = \begin{bmatrix} Q \\ I \end{bmatrix} \quad (11)$$

where I is the electric current, Q is the heat flux, C is the specific heat coefficient, K^t is the thermal conductivity, and K^e is the electrical conductivity. The time derivatives of T can be written as follows:

$$\dot{T} = \frac{\partial T}{\partial t} \{N\}^T \{T_n\} \quad (12)$$

Because of the symmetry of the model, to study the impact of electrode size and shape on thermal and energy performance, a two-dimensional (2D) FE model using shell elements was developed using the methodology described in (Sadati et al. 2018). Ten different configurations with various electrode spacings and electrode shapes were then modeled, and their performance were compared. FE elements for all pavement layers in the model, for a configuration including eight smooth solid circular electrodes with 8,150 elements, are shown in Figure 26.

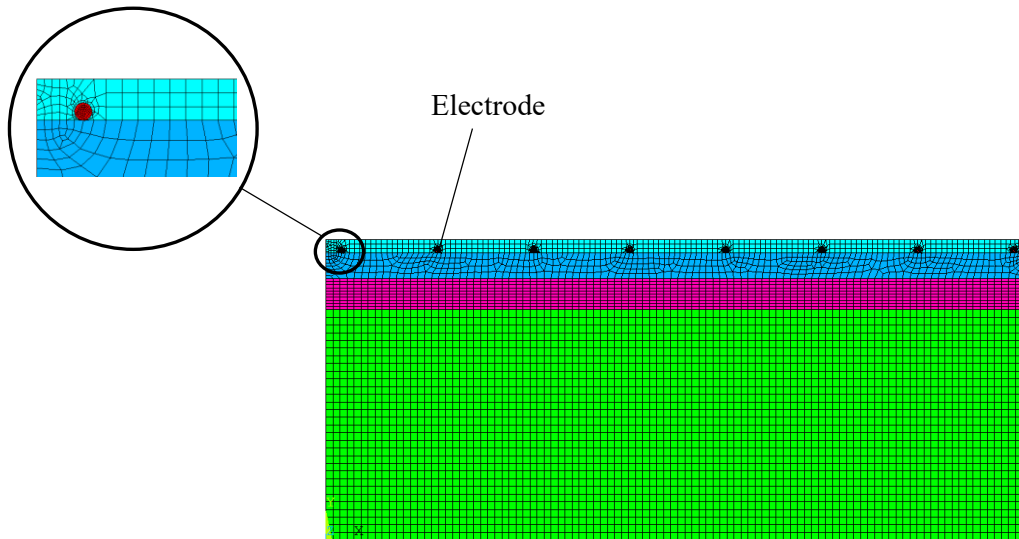

Sadati et al. 2020a, © 2020 Springer Ltd. All rights reserved., used with permission

Figure 26. FE model of ECON HPS configuration with eight solid circular electrodes

The time step used for the transient analysis was five minutes. Both the number of elements and the time step were checked to assure the convergence of results.

A total time of 120 minutes was used in performing the FE simulation to evaluate and identify electrode configuration options for the 10 test sections at the Iowa DOT site. Contour plots of the temperature distribution for test sections 1, 8, and 10 are shown in Figure 27 as sample configurations with 10, 8, and 6 embedded electrodes, respectively.

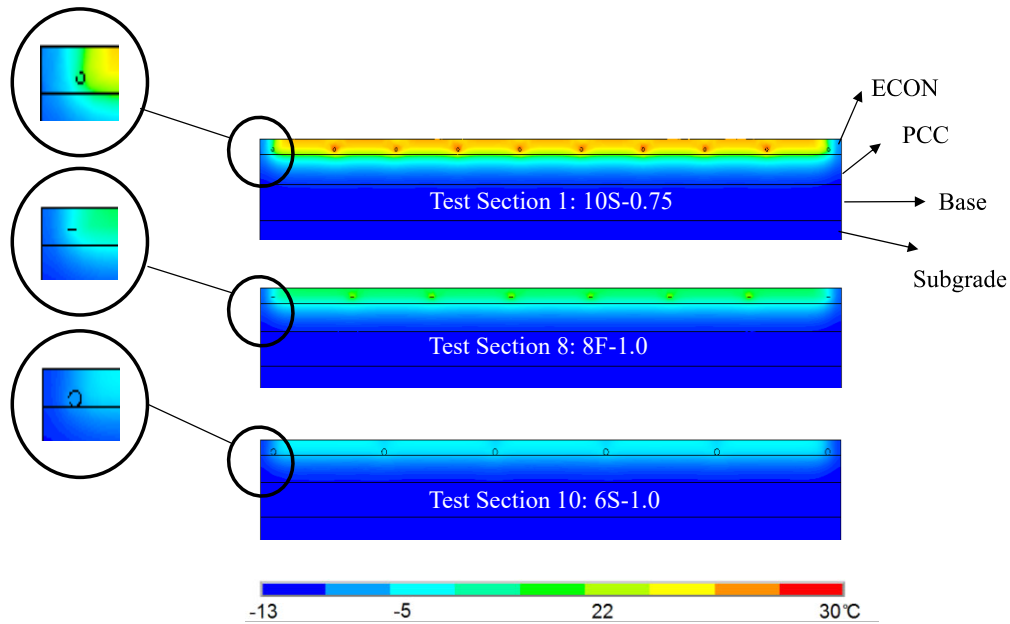

Sadati et al. 2020a, © 2020 Springer Ltd. All rights reserved., used with permission

Figure 27. Temperature distribution of three design configurations: with 10 (Test Section 1), 8 (Test Section 8), and 6 (Test Section 10) electrodes

Note for Figure 27 that the electrodes used Test Section 1 are smooth solid circular bars, with a 0.75 in. (20 mm) diameter; the electrodes for Test Section 8 are flat bars with a 1 in. (25 mm) thickness; and the electrodes for Test Section 10 are smooth solid circular bars with a 1 in. (25 mm) in diameter.

Other configurations exhibited similar temperature patterns with different temperature values. The temperature distribution and power input obtained for each design configuration are given in Figure 28 and Figure 29, respectively.

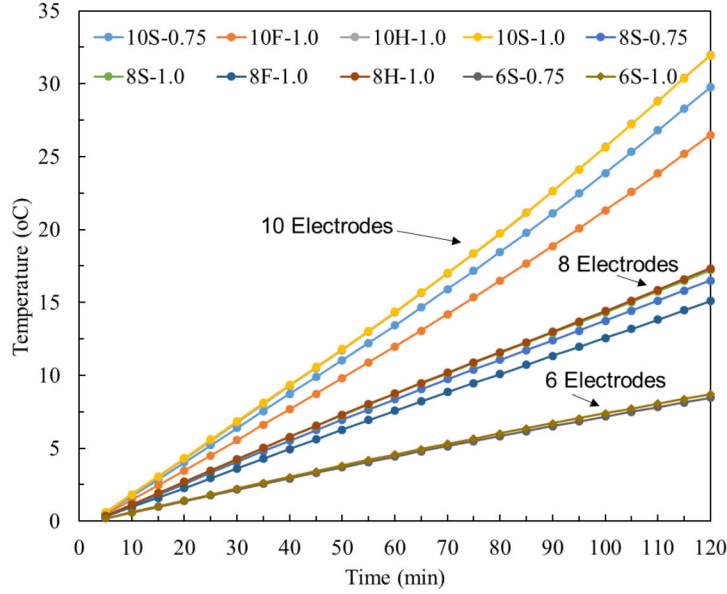

Sadati et al. 2020a, © 2020 Springer Ltd. All rights reserved., used with permission

Figure 28. Estimated average surface temperature of each configuration ($^{\circ}\text{F} = [^{\circ}\text{C} \times 1.8] + 32$)

Note that for Figure 28 the electrode design configuration option IDs are assigned to different configurations as “XY-D,” where X stands for the number of electrodes in the section; Y stands for the shape of the electrodes (S for smooth solid circular, H for hollow circular, and F for flat); and D stands for the diameter (in.) in the cases of smooth solid circular and hollow circular bars and the thickness (in.) in the case of flat bars.

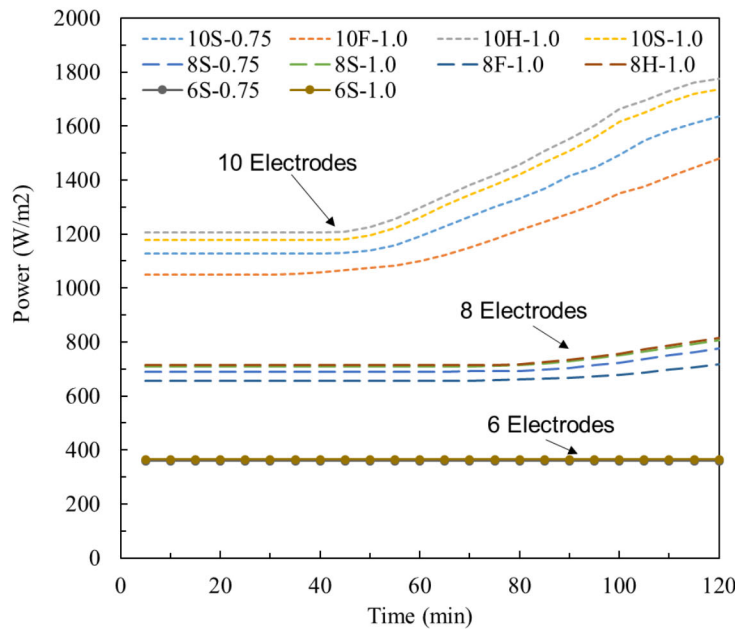

Sadati et al. 2020a, © 2020 Springer Ltd. All rights reserved., used with permission

Figure 29. Estimated power density of each configuration ($\text{W}/\text{ft}^2 = \text{W}/\text{m}^2 \div 10.76$)

As shown in both these figures, both thermal and energy performance changed significantly with changes in electrode spacing. It was also observed that the inclusion of more electrodes increases the power input to the slabs and the resulting energy consumption. It should be noted that in order to adjust this energy consumption, the voltage applied to each pair of electrodes could also be adjusted; however, this was not within the scope of evaluation of this project.

4.5. Sensor Selection

Sensor instrumentation for monitoring or controlling the pavement surface temperature—not to prevent system overheating—is a part of the construction of any ECON HPS. The presence of carbon fiber makes ECON act as a semiconductor that can conduct a significant current between its electrodes (cathode and anode), and sensors can measure the current passing through the ECON. For example, given most sensors for measuring temperature (e.g., thermocouples) use two conductors that produce a temperature-dependent voltage to be measured and correlated with temperature, thermocouples or other sensors that use electrical readings must be protected by an insulation of both the measuring tip and the cable. The cable must also withstand the ECON operational temperature that can range from -30°F (-34°C) to 50°F (10°C) and be protected for temperature-related measurements.

The research team tested the Arduino temperature sensor at the DSM site and found that some of them ceased to measure the temperature while the ECON HPS was operating and resumed measurement when the system stopped operating. Consequently, the research team decided to use Campbell Scientific thermocouples (Type E) for the Iowa DOT; they are electrically insulated and can operate in the ECON operational temperatures at both the measuring tip and in the cable, allowing continuous temperature measurement even when the system was turned on. In summary, it was found best to first test different types of sensors in small ECON prototype slabs prior to use in field construction.

4.6. Cross Slope Design

The cross slope for allowing water to run off the road surface is a geometrically necessary feature of each pavement. If the cross slope is insufficient, the water will stay on top of the heated section and potentially freeze after the system is not operational, so this feature is essential for designing ECON HPS technology. It becomes even more important when some part of the area is heated, while other parts are not. In that scenario, the designer should design a heated pass for the water to a drainage outlet point so that water resulting from snow/ice melting does not refreeze.

During the performance evaluation of the two slabs at DSM, the research team encountered ice accumulation between the heated slab and the regular slab, so special attention was given at the Iowa DOT site to allow water to drain faster from the heated sections.

5. IOWA DOT FULL-SCALE ECON HPS CONSTRUCTION DEMONSTRATION

5.1. Planning Considerations

The test site was located at the south parking lot entrance of Iowa DOT in Ames, Iowa (Figure 30a).



(a)

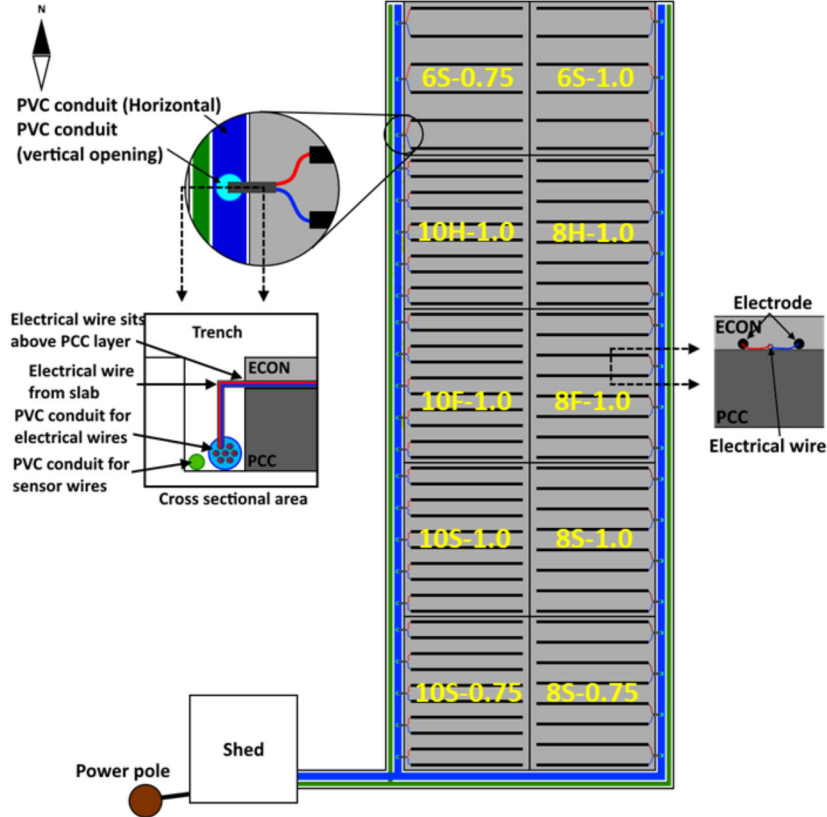

(b)

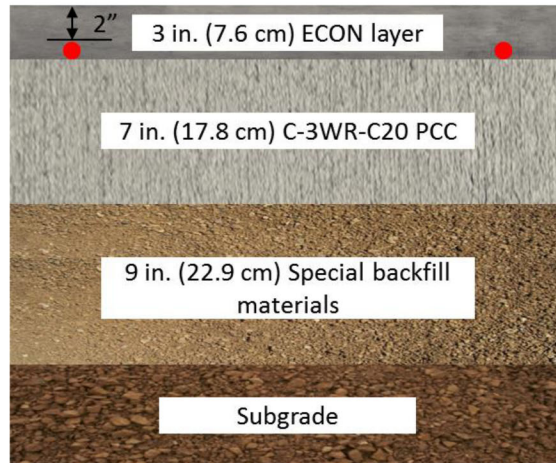

(c)

Adapted from Malakooti et al. 2020, © 2020 Elsevier Ltd. All rights reserved., used with permission

Figure 30. ECON HPS test site: (a) construction location, (b) plan view, and (c) cross-section view

As part of the reconstruction project, 10 slabs, each measuring 15 ft (4.6 m) long and 12 ft (3.6 m) wide, were dedicated to the ECON HPS implementation. The slabs near the south entrance were chosen as the heated pavement test site specifically because it was located in an area with a high and heavy volume of traffic.

5.2. Key Components of ECON HPS Technology

The key components of ECON HPS technology include an ECON layer (heating element), electrodes, temperature sensors, electrical wiring, polyvinyl chloride (PVC) conduit, a control system, and a power supply. This technology can be either constructed as an overlay on top of an existing pavement system if the pavement is in good condition or as a top layer of a two-lift paving for a new construction. Two-lift paving can be used to reduce construction material costs by reducing the ECON layer thickness, given it is necessary to heat only the surface of pavement where the snow and ice accumulation occurs.

Temperature sensors are installed to give the control system the ability to monitor the pavement surface temperature and set surface temperature to an above-freezing temperature (41°F [5°C]). This helps to reduce the possibility of overheating and to reduce energy consumption by not continuously operating the system when the surface temperatures are sufficiently warm. The energy consumption due to the thermal performance of the ECON HPS can be remotely monitored with wireless voltage and current sensors.

5.3. ECON HPS Design

The ECON HPS design consists of procedures to determine the required layer thicknesses for structural adequacy, electrode configuration based on the environmental conditions, and power

demand estimation. The layer thicknesses for the Iowa DOT ECON HPS project were designed based on a heavy traffic volume. Figure 30b shows the plan view of the construction site, which includes the 10 slabs, location of conduits, shed, and power supply.

All the electrical wiring from the electrodes to the power supply and the sensor wiring in each test section went through trenches to the shed. The control system and the data acquisition system were placed in the shed.

Figure 30c illustrates the cross-sectional view of different structural layers, which include a 9 in. (22.9 cm) special backfill base layer, 7 in. (17.8 cm) C-3WR-C20 regular PCC layer specified in the Iowa DOT Standard Specifications, which is explained in detail in Section 3.1 (Iowa DOT n.d.), and a 3 in. (7.6 cm) ECON layer. The electrodes were placed on top of the PCC layer, ensuring a 2 in. (5 cm) concrete cover on top of the electrodes.

The 10 constructed ECON slabs each have different electrode configurations. This was designed to monitor the performance of different electrode configurations in real pavement and environmental conditions. The electrode configuration for each test section is shown in Table 8.

Table 8. Electrode configuration in each slab

Test section	Section ID	No. of electrodes (spacing)	Size of electrodes, in. (cm)	Electrode type and shape
1	10S-0.75	10 (20.0 in./50.8 cm)	0.75 (1.9)	Smooth solid circular bar
2	10S-1.0	10 (20.0 in./50.8 cm)	1.00 (2.5)	Smooth solid circular bar
3	10F-1.0	10 (20.0 in./50.8 cm)	1.00 (2.5)	Flat bar
4	10H-1.0	10 (20.0 in./50.8 cm)	1.00 (2.5)	Hollow circular bar
5	6S-0.75	8 (25.5 in./64.8 cm)	0.75 (1.9)	Smooth solid circular bar
6	8S-0.75	8 (25.5 in./64.8 cm)	0.75 (1.9)	Smooth solid circular bar
7	8S-1.0	8 (25.5 in./64.8 cm)	1.00 (2.5)	Smooth solid circular bar
8	8F-1.0	8 (25.5 in./64.8 cm)	1.00 (2.5)	Flat bar
9	8H-1.0	6 (36.0 in./91.4 cm)	1.00 (2.5)	Hollow circular bar
10	6S-1.0	6 (36.0 in./91.4 cm)	1.00 (2.5)	Smooth solid circular bar

The electrodes chosen for field implementation were based on laboratory investigations and a numerical analysis conducted before the construction (Malakooti et al. 2019), and they are as follows:

- Smooth solid circular bars measuring 0.75 in. (1.9 cm) or 1.0 in. (2.5 cm)
- Hollow circular bars measuring 1.0 in. (2.5 cm) OD with 1/8 in. (0.3 cm) wall thickness
- Flat bars measuring 1.0 in. (2.5 cm) × 3/16 in. (0.4 cm)

Four slabs were designed with 10 electrodes (20.0 in. [50.8 cm] spacing), four slabs were designed with eight electrodes (25.5 in. [64.8 cm] spacing), and two slabs were designed with six electrodes (36.0 in. [91.4 cm] spacing).

Each test section was given a section ID, where the first number represents the number of electrodes in the test section (6, 8, or 10), followed by a letter representing the type of electrode (S for smooth circular solid bar, H for hollow circular bar, or F for flat bar), and it ends with a number indicating the size of the electrode in inches that has been used (0.75 or 1.0). As an example, a slab with an ID number of 10S-0.75 has 10 smooth solid circular bars with 0.75 in. (1.9 cm) outer diameter. The location of each constructed slab can be seen in the previously given Figure 30b.

5.4. Description of Materials

5.4.1. ECON and PCC Layer Mix Design

The ECON mix design was developed based on numerous trial batches in the laboratory (Malakooti et al. 2019) and the prior full-scale demonstration experience at DSM in 2016 (Sassani et al. 2018b).

First, the research team obtained samples from aggregate, cement, fly ash, and all the admixtures from the concrete plant. Second, numerous trial batches were made in the laboratory in order to attain a balanced ECON mix design to meet workability and mechanical property requirements in accordance with the Iowa DOT specifications as well as ensuring good electrical conductivity. Third, the concrete supplier was asked to batch 3 yd³ (2.3 m³) of the ECON mix design from the laboratory phase for laboratory testing. This step was taken as a precaution step before construction to ensure that the mixture from the batch plant was consistent with the construction specifications. It was found in the trial batch that the ECON was highly workable, but on the other hand, its electrical resistivity was high. Therefore, adjustments were made to the carbon fiber content and the admixture dosages to reduce the workability and resistivity. It was also found during the laboratory phase that (1) adding carbon fibers withholding moisture reduces the fiber loss during ECON production and (2) mixing fibers with aggregate before the presence of cementitious materials helped with achieving a better, more uniform fiber dispersion. Therefore, these suggestions were incorporated into the construction phase.

The finalized ECON mix design is shown in Table 9.

Table 9. ECON mix proportions for the Iowa DOT field implementation

Components		Type	Content lb/yd ³ (Kg/m ³)
Basic	Coarse aggregate	0.75 in. (1.9 cm) limestone	986.1 (585.0)
	Intermediate aggregate	0.375 in. (0.9 cm) chips	508.2 (301.5)
	Fine aggregate	Concrete river sand	1,079.2 (640.3)
	Cement	Holcim type I/II	632.7 (375.4)
	Fly ash	Class C	162.5 (96.4)
	Water	Potable water	336.9 (199.9)
	Carbon fiber	0.25 in. (0.63 cm) in length	1.25 (% vol.)
Admixtures	Air entrainment	EUCON AEA-92	3.0 oz/cwt (0.9 l/m ³)
	Water reducer	EUCON WR 91	7.5 oz/cwt (2.3 l/m ³)

The mixture contained 1.25% carbon fiber by volume and 20% fly ash replacement. The significant differences between this mixture and its predecessors (Sassani et al. 2017, 2018a, 2018b) were the addition of 20% fly ash to increase workability and durability and the elimination of methylcellulose fiber dispersion agent and corrosion inhibitor admixtures in order to decrease the possibility of unwanted chemical reactions between the admixtures. In addition, the carbon fiber content was increased from 1% to 1.25% by volume to account for any potential carbon fiber losses that may take place during batching and placing. The standard PCC layer (bottom layer) mix design was C-3WR-C20, and it is composed of 45% fine and 55% coarse aggregate with 20% Class C fly ash. It is worth mentioning that the typical electrical resistivity of a standard concrete is about $3.54 \times 10^5 \Omega\text{-in.}$ ($9 \times 10^5 \Omega\text{-cm}$) (Malakooti 2017, Malakooti et al. 2018, Melugiri-Shankaramurthy et al. 2019), while achieved electrical resistivity for ECON was 512 $\Omega\text{-in.}$ (1,300 $\Omega\text{-cm}$) due to the addition of 1.25% carbon fiber into the mixture.

5.4.2. Electrodes

Electrodes in an ECON HPS have the role of applying the electricity to the ECON layer due to their high electrical conductivity properties. All the electrodes chosen were 316L grade stainless steel, which has promising resistance to corrosion. Therefore, the electrodes are better suited to withstand degradation and cracking, which will lead to system efficiency reduction and electrode debonding from ECON.

Circular and flat bar electrode geometries were chosen rather than angled electrodes, which have been used in predecessor projects (Abdualla et al. 2018) to minimize stress concentrations and thus reduce cracking potential. In addition, the chosen electrode geometries also eliminated using fiberglass bars perpendicular to the electrodes, which have been used in other projects to minimize the possible cracking (Abdualla et al. 2018).

All the electrodes were anchored to the PCC layer to secure them and minimize their movements during the pavement construction. The wires that were used to connect the electrodes to the

power supply were specially selected for 208 VAC, 600 A usage. The wires were also designed for use in a rough environment, such as a construction project, and had a special insulation layer.

5.4.3. Sensors and Data Acquisition System

Both wired and wireless sensors were utilized in the demonstration project. Table 10 and Table 11 summarize the types and numbers of sensors instrumented on 10 ECON slabs and 1 PCC slab (a control slab).

Table 10. Types and numbers of sensors instrumented on 10 ECON slabs

Sensor type	Sensor location	Sensors per single test section	Number of test sections	Sensors for total test sections
Thermocouples ¹	ECON, PCC, base, subgrade	6	10	60
Strain gauges ¹	ECON	8	3	24
Current sensors	Electrical power supply panel	1	10	10
Voltage sensors	Electrical power supply panel	1	10	10
Extra wireless temperature sensors ²	Outside ECON HPS			2

¹ To be connected into data acquisition system for recording measurements; ²several sensor trees using 15 wireless sensors that can be located far enough from the ECON slabs to be used as a reference

Table 11. Types and numbers of sensors instrumented on one PCC slab

Sensor type	Sensor location	Sensors per single test section	Number of test sections	Sensors for total test sections
Thermocouples ¹	PCC, base, subgrade	6	1	6
Strain Gauges ¹	PCC	8	1	8

¹ To be connected into data acquisition system for recording measurements

A total of 66 Campbell Scientific thermocouples (Type E), 32 GEOKON strain gauges, 10 wireless Monnit voltage sensors, and 10 wireless Monnit current sensors were installed. Thermocouples were embedded within each layer in the 10 ECON slabs and 1 PCC slab. Strain gauges were embedded within the ECON layer and PCC layer in the 10 ECON slabs and embedded within the PCC layers in the 1 PCC slab. Voltage and current wireless sensors were installed in the power distribution box within the shed to monitor the electrical consumption of each test section.

All the sensors were tested in the laboratory prior to the field installation. In order to gather all the data, two Campbell Scientific CR6 data loggers and five Campbell Scientific AM16/32B Multiplexers were installed in the shed. The Monnit voltage and current sensors transmit the readings to a gateway before being transferred to a cloud-based real-time monitoring system. All other sensors were connected to a laptop in the shed, which can be accessed remotely through a wireless hotspot provided in the shed. Therefore, system operation tasks, including turning the slabs on/off, data collection, and real-time monitoring can easily be conducted remotely.

5.4.4. Control System

The research team had selected a robust control system for this project. A PLC is an industrial standard control system. The PLC is a modular system comprising of a CPU, analog temperature input module, digital output module, and relays. In addition, the modular design will allow for expansion if the research team deems necessary in the future. One embedded thermocouple sensor in the center of each slab, 0.5 in. (1.3 cm) from the pavement surface, was linked to the PLC system. This enables the control system to monitor the pavement surface temperature. Once the pavement surface temperature drops below a predetermined temperature (41°F [5°C]), the control system activates the 120/208 VAC power source using the relays to generate heat within the ECON layer. The ECON system can melt ice and snow much quicker with 208 VAC compared to 120 VAC and can be used in times when the winter weather conditions are particularly harsh (e.g., snow/ice storms during a polar vortex), and the road serviceability needs to be maintained continuously under such harsh conditions.

5.5. Instrumentation and Installation Methods

The instrumentation plan for the ECON HPS consists of steps that were taken for installing electrodes, sensors, data acquisition system, and a power supply system. These steps have been developed based on extensive previous experiences during both field and laboratory experiments.

Figure 31 depicts the installation procedures for different components during the construction phase.



(a)

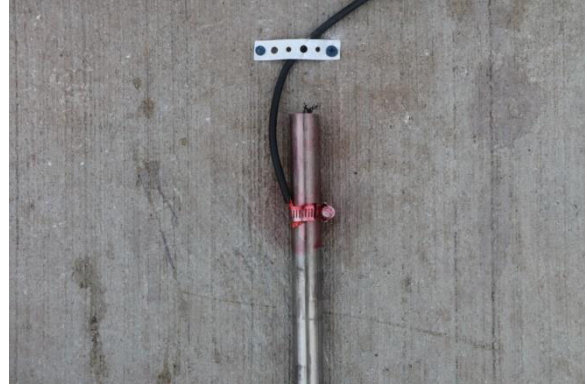

(b)

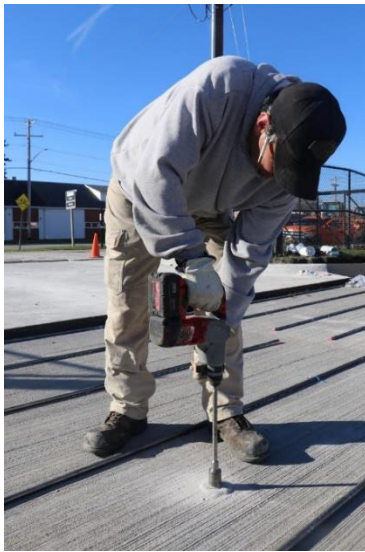

(c)

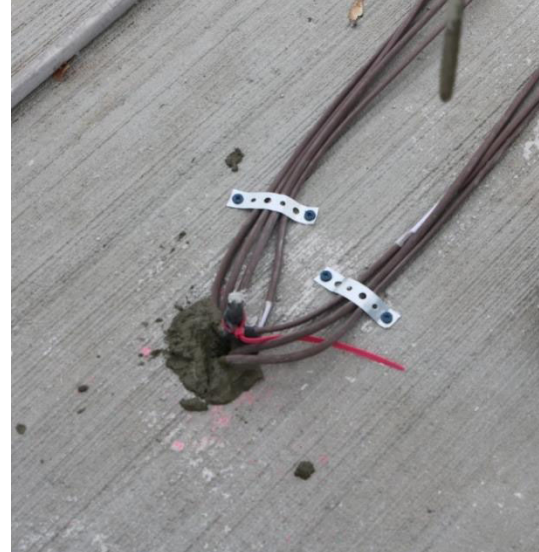

(d)

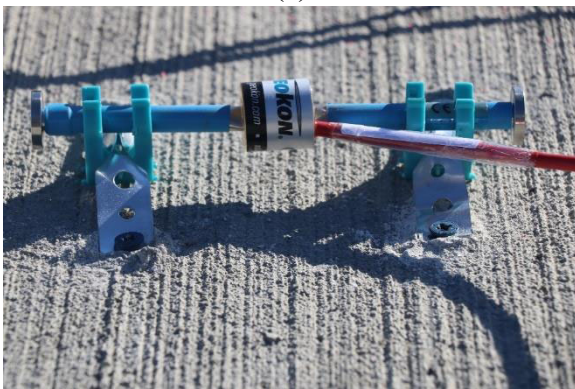

(e)

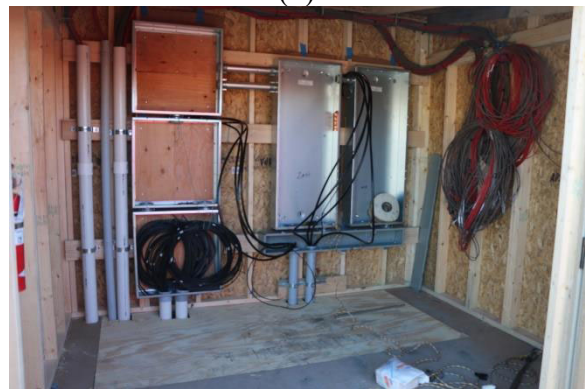

(f)

Malakooti et al. 2020, © 2020 Elsevier Ltd. All rights reserved., used with permission

Figure 31. Electrode and sensor wiring and instrumentation: (a) anchor electrode to PCC layer, (b) wire electrodes, (c) install thermocouple sensor tree, (d) place thermocouple sensors, (e) install strain gauges, and (f) wire shed and sensors in shed

5.5.1. Installation of Electrodes

The location of each stainless-steel electrode was marked on each slab, and the electrodes were fixed using steel straps, as shown in Figure 31a. A drill was used to make the holes and secure the straps to the PCC layer. After anchoring the electrodes, all the electrodes were connected to electric wires using gauge-ring wire connectors for flat bars and hose clamps for circular bars (see Figure 31b).

5.5.2. Sensors Instrumentation

Sensors and a surveillance camera were installed to monitor the ECON HPS operation performance. The sensor types for this purpose include temperature sensors (i.e., wired thermocouples and wireless temperature sensors manufactured by Monnit), strain gauges, current sensors, and voltage sensors. Temperature sensors (i.e., wired thermocouples and wireless temperature sensors) can be utilized to continuously monitor ECON HPS temperature responses for activating and deactivating the ECON HPS operations. Strain gauges can be installed as well to capture the strain behavior of the ECON slabs under diurnal and seasonal environmental loads, the electric heating process, as well as passing vehicles. Furthermore, current sensors and voltage sensors (e.g., wireless electricity monitoring sensors manufactured by Monnit) can also be employed to monitor electric properties for estimating power consumption and operation cost.

Sensor instrumentation locations were chosen based on the critical response locations within a slab with regard to the temperature and strain variations. The temperature trees were mounted on a 0.25 in. (0.6 cm) fiberglass bar in order to eliminate temperature and electricity gradients in different layers. A hole was first drilled in the PCC layer at the center of each slab (see Figure 31c), and the temperature trees were installed inside and secured with cement grout (see Figure 31d). Each temperature tree consisted of six thermocouples in the following locations: top and bottom of the ECON layer, the middle and bottom of the PCC layer, the middle of the base layer, and one sensor in the subgrade layer. The detailed instrumentation processes of the temperature sensors are given in the following steps:

- Step 1: Mark sensor location after base PCC layer hardens
- Step 2: Drill holes at these predetermined locations at desired depth
- Step 3: Pull sensor cables through PVC conduits
- Step 4: Make sensor trees by mounting sensors at a predetermined height on the rods
- Step 5: Insert sensor trees into these holes
- Step 6: Check depth of sensors
- Step 7: Organize sensor cables
- Step 8: Connect sensors to data acquisition system and check sensor survivability

Strain gauges were mounted on the PCC layer using two plastic chairs and steel straps (see Figure 31e). The steel straps were screwed to the PCC layer to secure them. In the case where two strain gauges needed to be placed at different depths, two 0.25 in. (0.6 cm) fiberglass bars were used to place and secure the strain gauges. The chosen locations of strain gauges were the

center, edge, corner in the wheel path direction, and corner in a diagonal direction. The strain gauges were installed both in the ECON layer and PCC layer. The strain gauge configuration was chosen to measure the strain in both layers to monitor the effect of heating in the ECON layer. The detailed instrumentation processes of strain gauges are given in the following steps:

- Step 1: Mark sensor location after base PCC layer hardens
- Step 2: Pull sensor cables through PVC conduits
- Step 3: Set up strain gauges by using plastic chairs
- Step 4: Check strain gauges height
- Step 5: Use the concrete anchor to fix the location of strain gauges
- Step 6: Organize sensor cables
- Step 7: Connect sensors to data acquisition system and check sensor survivability

Sensors wires were guided to a separate PVC pipe to the shed (see Figure 31f). The PVC pipe for electrical wiring was not chosen to host the sensors wires to prevent possible interferences in the sensor signals and for safety purposes.

5.5.3. Integration of Power Supply and Control System

There was no existing power supply source close to the construction site; therefore, a new 45-1 pole with 3-100kVA XFMRS was placed at the southwest corner of the site. A meter was installed on the pole to measure electrical power usage, and a power line trench was excavated from the pole to the shed. This enabled powering the ECON HPS test area using either a three-phase 208 VAC or a single phase 120 VAC, both with a maximum of 600 A source.

Two three-phase double pole power panels were installed in the shed with two circuit breakers. Each circuit breaker can feed five slabs with 120/208 VAC. The three-phase 208 VAC was achieved by using two lines, one for each phase, while the 120 VAC was carried in each single line. The 120 VAC was achieved using one line and the neutral. The different electrode configuration design caused each slab to draw a different amount of current compared to the other slabs. Thus, the research team with the assistance of the Iowa DOT and/contractor conducted a series of tests and simulations and grouped the slabs in a way to distribute the power load evenly within each phase and to eliminate overloading on one phase.

Another added feature of using a PLC as a control system is the electrode-based control. The electrode-based control feature gave the research team an extra degree of control to create different electrode configurations (spacing) within one slab by being able to turn on/off individual electrodes. Therefore, the research team added more relays for the test slabs with 10 electrodes (4 slabs) to incorporate this feature. The electrode wiring diagram for the 10 electrode slabs is shown in Figure 32a.

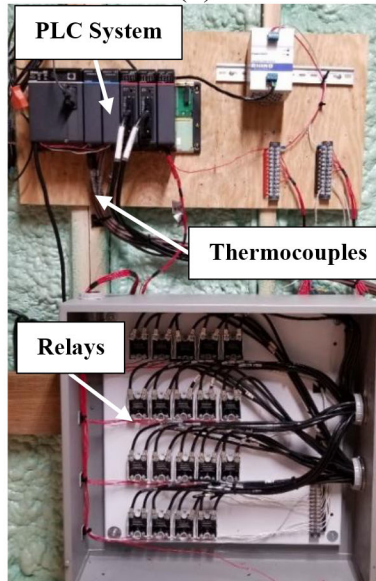
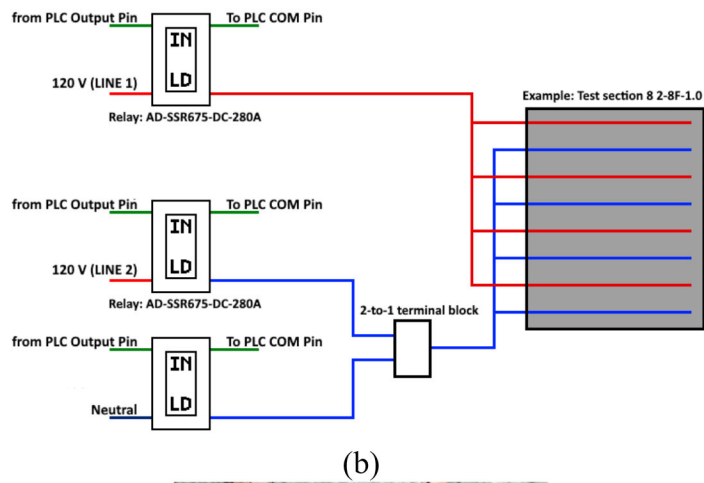
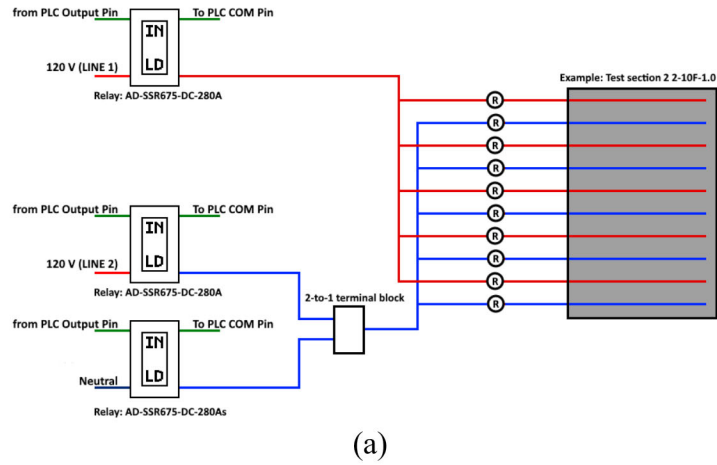

Malakooti et al. 2020, © 2020 Elsevier Ltd. All rights reserved., used with permission

Figure 32. PLC control configurations: (a) electrode-based control, (b) slab-based control, and (c) system and relay wiring

The other six slabs were designed using slab-based control, which only turned on and off all of the electrodes in each slab at once (Figure 32b). The PLC system and its wiring are shown in Figure 32c.

The electrical work mainly conducted by the ISU research team was as follows:

- Prepare the design and programming of the PLC system
- Develop the PLC system hardware
- Test the developed PLC system in the laboratory to ensure the system worked as intended two weeks before installation
- Run initial tests to ensure the system was working properly

The Iowa DOT and/or contractor involved efforts on the electrical work were as follows:

- Confirm power source availability for the ECON HPS construction at least one month prior to construction (Iowa DOT)
- Provide the specification and location of the electric power supply panel at least one month prior to construction (Iowa DOT)
- Provide power outlets near the decided location to power the PLC system and connected laptop (Iowa DOT)
- Decide on the appropriate wire type (American wire gauge [AWG], strand, insulation, etc.) for a source to the electrode connections (Iowa DOT or contractor)
- Connect electrodes to ground conduit and wires to the PLC system (Iowa DOT or contractor)
- Install the PLC hardware into the electrical power supply panel based on the guidelines (Iowa DOT or contractor)
- Connect signal wires from the PLC output module to relays (Iowa DOT or contractor)
- Connect wires from source and wires from electrodes to relays (Iowa DOT or contractor)
- Check the connections of the PLC system to be safe and meet safety protocols (Iowa DOT or contractor)

5.5.4. Managing the Heat Dissipation by Relays

The solid-state relays generate heat, and this heat should be dissipated carefully to protect the relays for ensuring safe ECON HPS operation. To improve the heat transfer for dissipating the generated heat by the relays, the following steps (see Figure 33) were taken:

- Install relays on steel plates to allow for a higher rate of heat transfer through the backside of the relays
- Install cooling fans on the box covers to constantly blow on the relays



Figure 33. Cooling fans installed on the relays

Laboratory tests showed that the maximum measured temperature reached by the relays is about 131°F (55°C), while the allowable working temperature for these relays is 194°F (90°C). The detailed approval procedures for operating the ECON HPS are presented in Appendix B.

5.6. Construction Procedure

Construction started on October 11, 2018 and lasted for four weeks due to the weather conditions. The existing pavement was a 40-year-old PCC pavement with numerous cracks at the joints and midspan. The pavement had also been rehabilitated at several spots because of extensive damages. This parking lot section experiences a high amount of heavily loaded traffic, including 18-wheeler tractors and trailers, given that it's near the entrance of the Iowa DOT receiving station. The full-scale demonstration project was a reconstruction project, and the first task was to remove the existing 6 in. (15.2 cm) concrete pavement. The existing pavement did not have a base layer, and it lacked any drainage system; therefore, a geofabric system was utilized on top of the subgrade, and a 9 in. (22.9 cm) special backfill layer was compacted for the base layer.

The ECON HPS was designed with two layers: 7 in. (17.8 cm) standard PCC layer (bottom layer) and 3 in. (7.6 cm) ECON layer (top layer). The construction steps in sequence are shown in Figure 34.



(a)



(b)



(c)



(d)



(e)



(f)



(g)



(h)

Malakooti et al. 2020, © 2020 Elsevier Ltd. All rights reserved., used with permission

Figure 34. ECON HPS construction steps: (a) place C-3WR-C20 PCC placement, (b) screed PCC layer, (c) install electrodes, (d) place PVC conduit, (e) clean surface, (f) inspect ECON layer, (g) place and compact ECON layer with vibrating screed, and (h) spray curing compound on surface

Dowel bars (0.75 in. [1.9 cm] in diameter) were used for proper load transfer between the adjacent slabs at sawn joints. A joint spacing of 15 ft (4.57 m) was designed, and the joints were matched with the surrounding concrete slabs. A vibrating screed was used to compact the PCC layer (Figure 34a). A broom was used perpendicular to the traffic flow after finishing the PCC layer to roughen the surface and increase the bond between the bottom PCC layer and the top ECON layer (Figure 34b). A curing compound was not suggested for curing the PCC layer due to its potential adverse impact on the bond between the two layers; therefore, wet curing using curing blankets was chosen for the bottom PCC layer.

The research team started mounting the electrodes on top of the PCC layer (Figure 34c). The electrodes were first washed and then dried in order to remove any debris or possible oil on their surface. This was an essential step to ensure a good bond between each electrode and the ECON layer. The perimeter of the ECON test sections, where it meets the standard concrete sections, were isolated using expansion joints to minimize any interaction and potential strain build-up with other unheated standard concrete slabs. The strain gauge and thermocouple trees were installed, and their wires were guided to their designated PVC conduits (Figure 34d). The surface of the PCC layer got cleaned using an air blower and damped to ensure a good bond between the two lifts (Figure 34e). A white flag was installed at each sensor location so that the sensors did not get stepped on during the ECON placing (Figure 34f).

The ECON layer was placed on October 25, 2018, and a vibrating screed was used to compact this layer (Figure 34g). After the ECON layer was placed, a curing compound was sprayed on top of the test section (Figure 34h) to prevent moisture loss. The shed was placed in the southwest corner of the test section, and the wires were installed to connect the electrodes to the power supply source. Meanwhile, the joints were cut full depth through the ECON layer to match those in the bottom PCC layer. The last step in the construction phase was to fill the trenches that hold the electrical and sensor PVC conduits with 6 in. (15.2 cm) hot-mix asphalt.

6. IOWA DOT ECON HPS PERFORMANCE EVALUATION

6.1. State of Practice

The current winter maintenance operation conducted by the Iowa DOT ground crew for their parking lot uses eight crews with eight units of snow-removal equipment. It takes the ground crew an average of five hours to remove snow from the entire Iowa DOT parking lot in a typical 2 in. (5 cm) snow event. The ground crew used 10 tons (9 metric tons) of deicing chemicals and sand between January 1, 2019, and February 20, 2019. The ground crew process is to first plow and gather the snow in several designated areas in the parking lot and then apply deicing chemicals and sand to the snow remaining on the pavement. Then, the crew hauls the gathered snow from the designated locations and transfers it to the Iowa DOT south parking lot to ultimately be melted by the sun. The Iowa DOT staff sends several emails to its employees before each snow event asking them to move both personal and Iowa DOT-owned vehicles from the south parking lot to facilitate the winter snow-removal operation.

Throughout the winter season, deicing chemicals usually get transferred to grassy areas, resulting in the surrounding vegetation being killed, and the sand accumulates. Thus, these processes require the ground crew each spring and summer to plant new grasses, especially near the parking lot, and gather the sand that was spread.

This current state of practice for removing ice and snow is time-consuming, labor-intensive, and environmentally unfriendly due to the usage of deicing chemicals.

6.2. First Seasonal Evaluation (2019)

Figure 35 depicts the ECON HPS system performance during February and March 2019.

The resistive heating performance of the ECON HPS was capable of maintaining a snow- and ice-free surface, while the remaining parking lot area was covered with about 2 in. (5 cm) of snow. The depicted snow event in Figure 35 began at 8 p.m. on February 11, 2019, and lasted until 2 a.m. the next day (6 hours), and the average air temperature and relative humidity in this period were 17°F (-8.4°C) and 86%, respectively. The system began operating at 8 p.m. and was capable of melting all the snow by 11 p.m. (3 hours) and maintaining a snow-free surface until the snow event ended. Appendix C was developed to show the step-by-step procedure of how to use the PLC program to operate the ECON HPS system.

The power density (P) is the amount of energy consumed by each slab per unit area, and it was calculated using the average current usage (I) and the voltage applied to the slabs during a snow event. The applied voltage for the operation was chosen to be 120 VAC for the ECON HPS performance evaluation. The power density range for all the slabs was between 10.2 W/ft² (109.8 W/m²) and 45.6 W/ft² (491.5 W/m²), with an average of 24.6 W/ft² (265.1 W/m²).

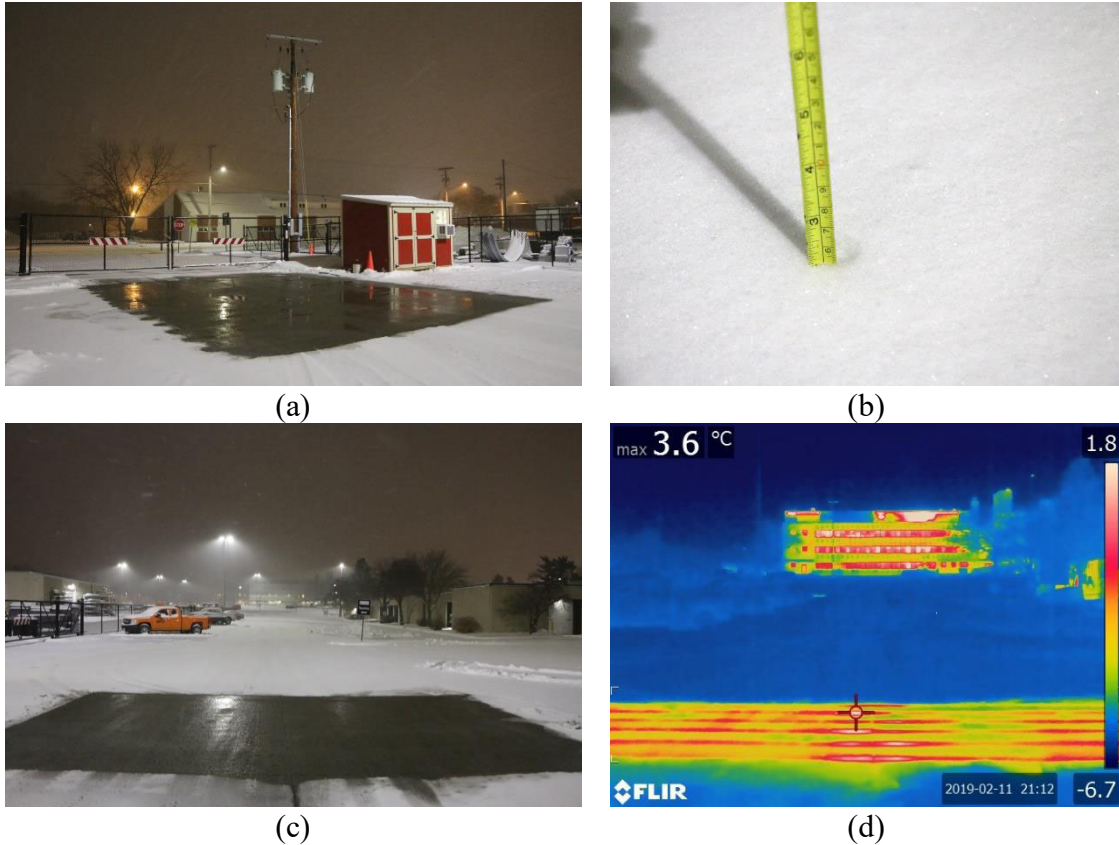

Malakooti et al. 2020, © 2020 Elsevier Ltd. All rights reserved., used with permission

Figure 35. ECON HPS heating performance: (a) southside slabs performance, (b) 2 in. (5 cm) of snow accumulation on surrounding slabs, (c) northside slab performance, and (d) infrared thermography ($^{\circ}\text{F} = [^{\circ}\text{C} \times 1.8] + 32$)

Given resistivity variation due to carbon fiber dispersion within each test section was observed among the slabs, to compare the power demand for each electrode configuration independent of slab electrical resistivity, the power density was normalized by the resistivity measurement for each slab. This normalization was necessary given the effect of resistivity is the linear inverse of that of power density, meaning that a slab with higher resistivity has a lower power density and vice versa. This normalization was essential to determine only the effect of electrode configuration and eliminate the effect of ECON resistivity on the analysis. The normalized power density for each test section and slab surface temperatures while in operation are shown in Figure 36 and Figure 37, respectively.

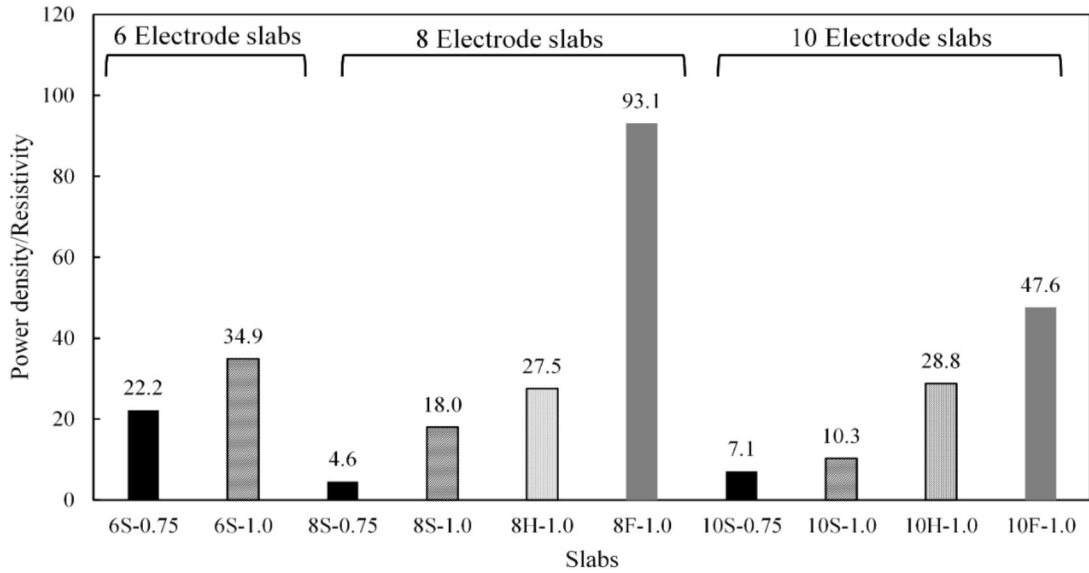
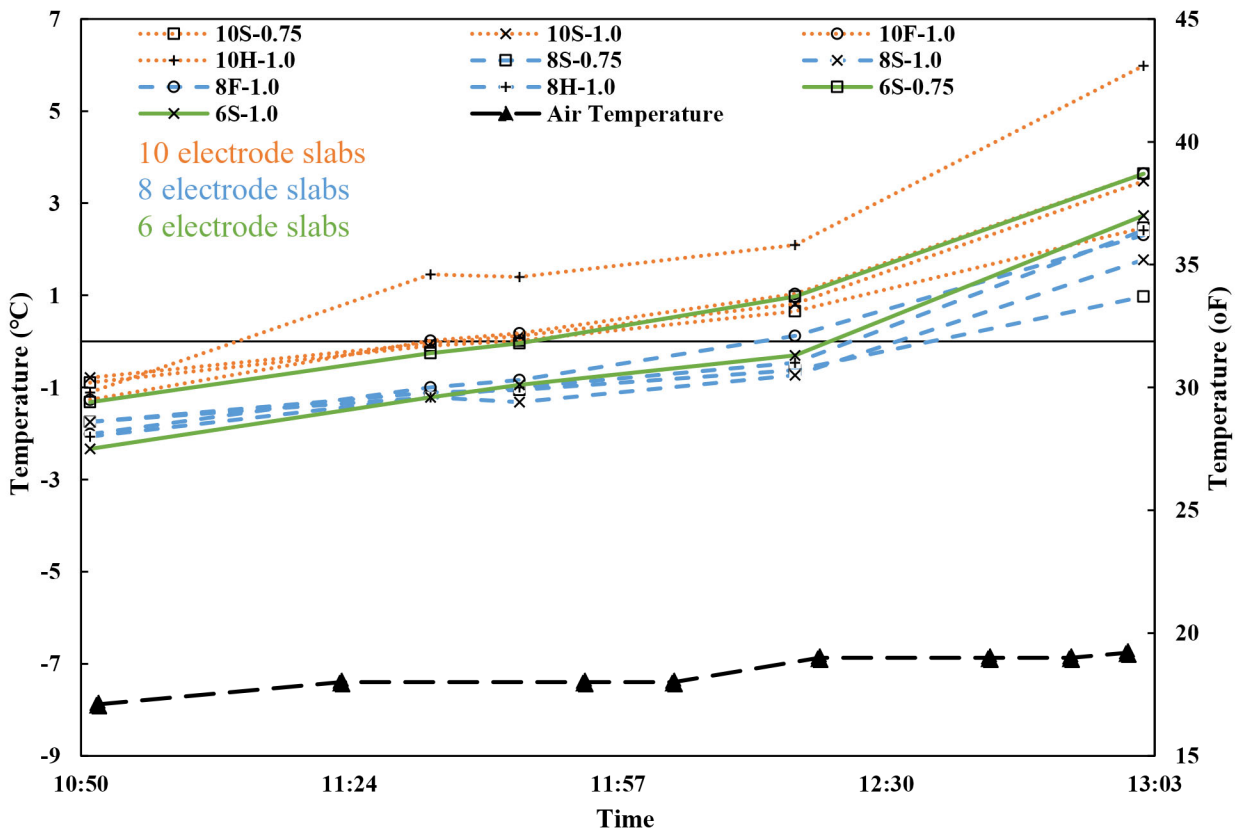

Figure 36. Power density per square feet per resistivity of each slab



Malakooti et al. 2020, © 2020 Elsevier Ltd. All rights reserved., used with permission

Figure 37. Slab surface temperature and air temperature vs. time

As shown in Figure 37, the electrode configuration directly affects the power density. In all cases, a flat bar, a 1.0 in. (2.5 cm) hollow bar, a 1.0 in. (2.5 cm) solid bar, and a 0.75 in. (1.9 cm) solid bar have the same trend that power density decreases when the number of electrodes increases. However, the flat bar has the highest and the 0.75 in. (1.9 cm) solid bar the lowest power density. It was also found that by increasing the electrode diameter in circular solid bars from 0.75 in. (1.9 cm) to 1.0 in. (2.5 cm), the power density increased in all different spacing options, due to the increase in the contact area between the electrode and the ECON layer. The power density was also decreased for the flat bar and the 1.0 in. (2.5 cm) circular solid bar by decreasing the spacing (increasing the number of electrodes within a slab).

Figure 37 shows the thermal performance of each slab and air temperature versus time. These data were gathered from thermocouples placed 0.5 in. (1.3 cm) below the pavement surface. The temperature in each slab increased after the slab was energized, but after some time, the slab temperature stayed constant due to melting snow on the surface (phase change). The 10H-1.0 slab exhibited the highest temperature increase (13.3°F [7.4°C] in two hours), while the 8S-0.75 slab exhibited the lowest. The average temperature rise for all the slabs was 9°F (5°C) in two hours. The slabs with 8 electrodes exhibited inferior heating performance compared to those with 10 electrodes.

6.3. Second Seasonal Evaluation (2020)

The ECON HPS slabs' thermal performance was evaluated during the 2019–2020 winter season, and the results are depicted in Figure 38.

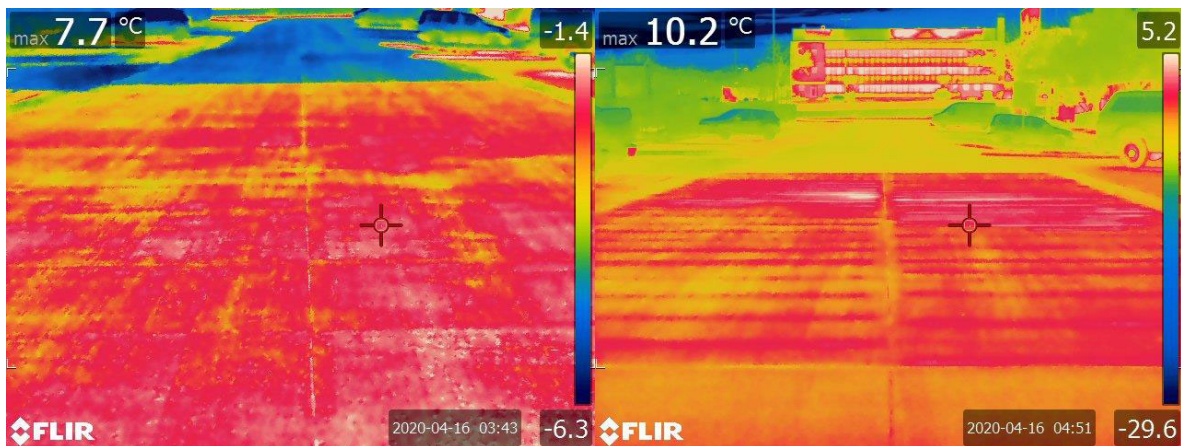

Figure 38. Thermal performance of ECON HPS slabs in the second seasonal evaluation
 $(^{\circ}\text{F} = [^{\circ}\text{C} \times 1.8] + 32)$

Figure 39 depicts current measurements drawn from each slab during the second seasonal evaluation.

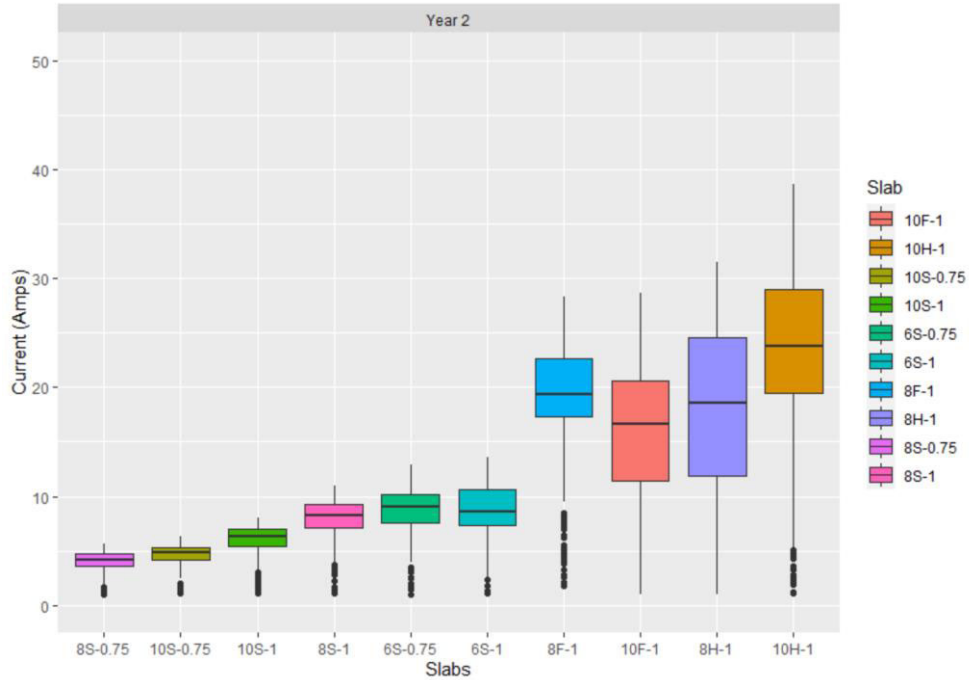

Figure 39. Second year current measurements of each slab

These data were used to calculate the power density for each slab shown in Figure 40, with higher power density translating to higher thermal performance.

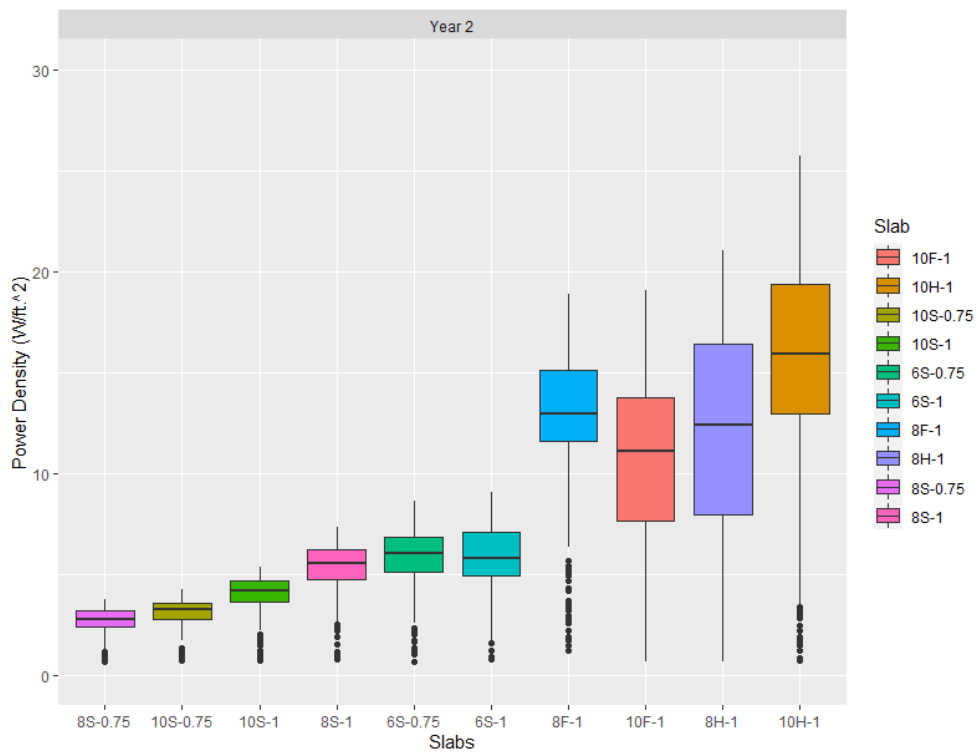

Figure 40. Second year power density measurements of each slab

Slab 10H-1 exhibited the highest and best thermal performance, while slab 8S-0.75 exhibited the poorest thermal performance among the 10 different design configurations. Figure 41 shows the measured resistivity of the 10 slabs during this seasonal evaluation.

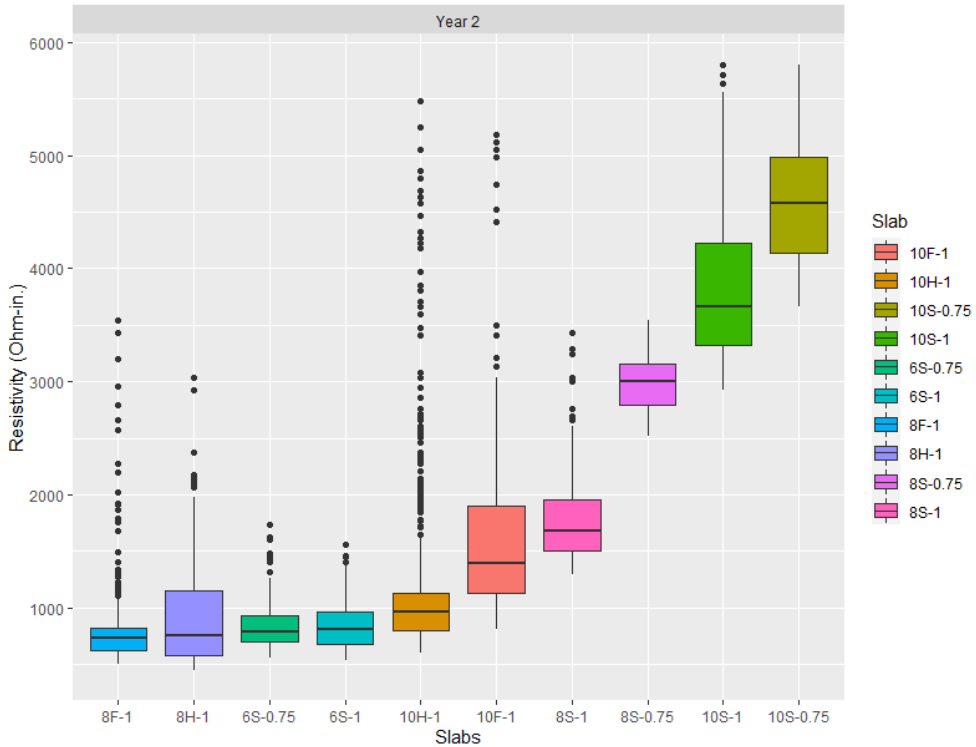

Figure 41. Second year slab resistivity measurements

Comparing the resistivity and power density data shows a clear relationship between resistivity and power density. Slabs with higher resistivity generated less power density and lower thermal performance, and vice versa.

6.4. Third Seasonal Evaluation (2021)

The ECON HPS slabs’ thermal performance, also evaluated during the 2020–2021 winter season, are depicted in Figure 42.

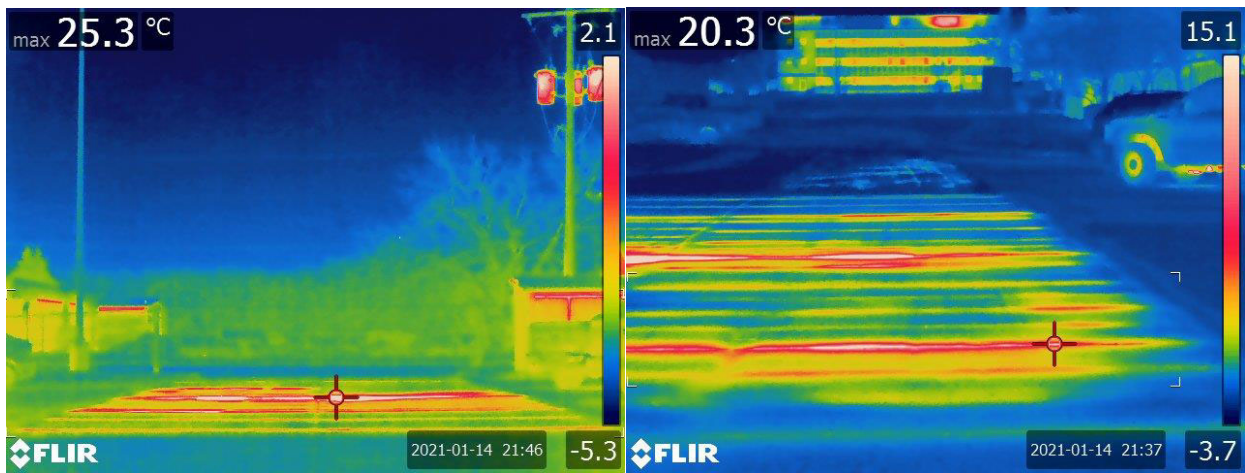

Figure 42. Thermal performance of ECON HPS slabs in the third seasonal evaluation ($^{\circ}\text{F} = [^{\circ}\text{C} \times 1.8] + 32$)

Figure 43 depicts current measurements drawn from each slab during the third seasonal evaluation.

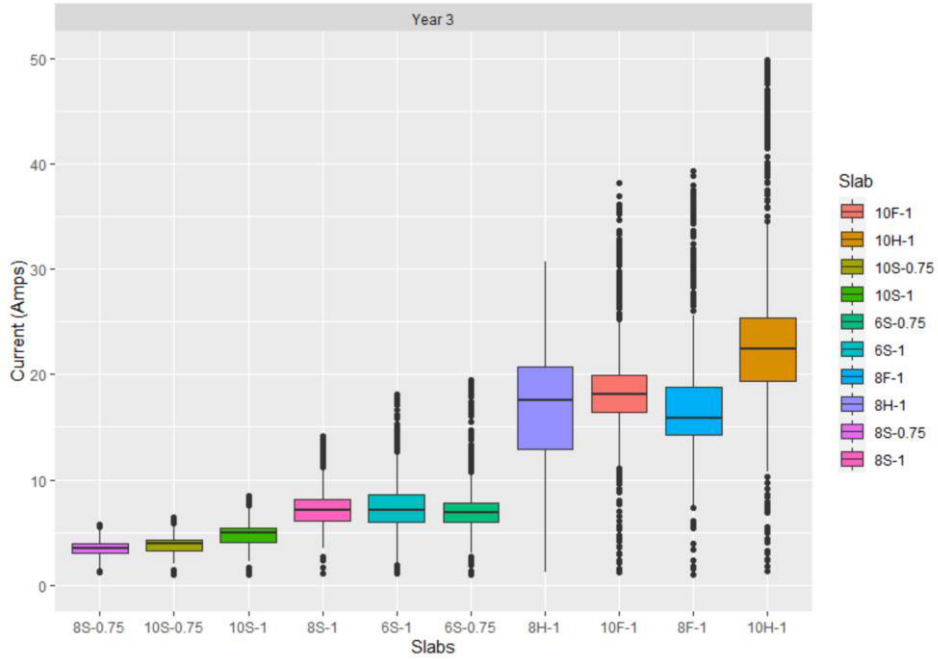

Figure 43. Third year current measurements of each slab

These data were used to calculate the power density shown in Figure 44 for each slab, with higher power density translating to higher thermal performance.

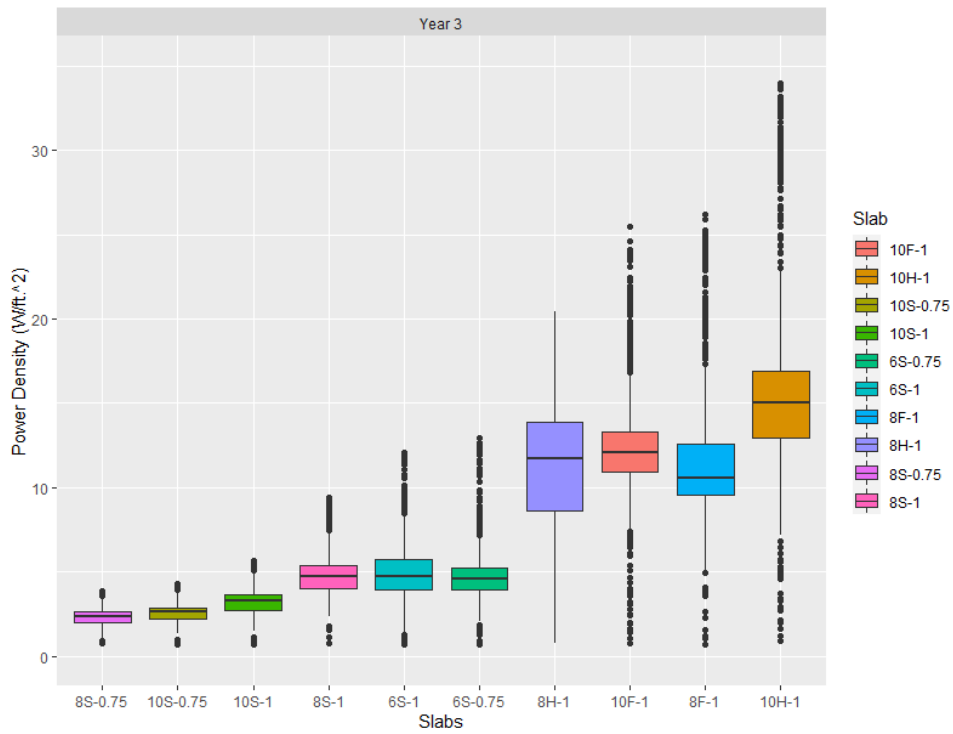

Figure 44. Third year power density measurements of each slab

Similar to observations from the second seasonal evaluation, slab 10H-1 exhibited the highest and best thermal performance while slab 8S-0.75 exhibited the poorest thermal performance slab among the 10 different design configurations. Figure 45 shows the measured resistivity of the 10 slabs in the third seasonal evaluation.

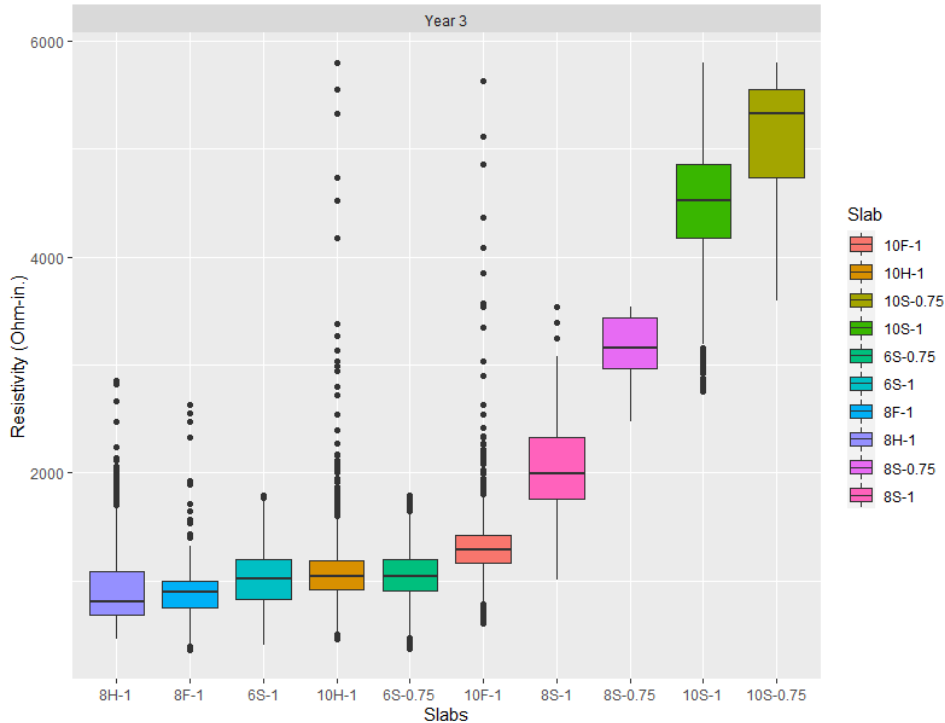

Figure 45. Third year resistivity measurements of each slab

Comparing the resistivity and power density data shows a clear relationship between resistivity and power density. Slabs with higher resistivity generated less power density and lower thermal performance, and vice versa.

6.5. Structural Evaluation

A structural evaluation of both the control and heated sections at the Iowa DOT test site was performed on September 30, 2019, using falling weight deflectometer (FWD) testing. An Iowa DOT FWD vehicle was used to perform the FWD testing with assistance from the Iowa DOT's special investigations section, as shown in Figure 46.



Figure 46. Iowa DOT FWD vehicle

The FWD load levels were 9 kips (40 kN), 12 kips (53.4 kN), and 15 kips (66.7 kN), with the loads applied both at the slab centers and at joints. The average FWD deflection plot for both the control and heated slabs is shown in Figure 47.

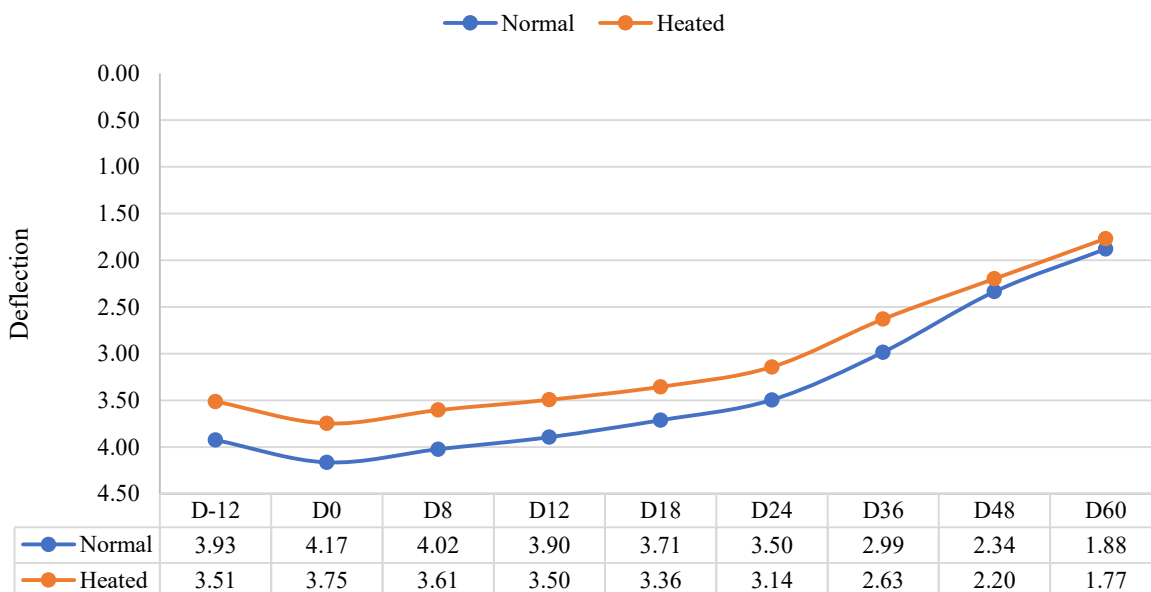

Figure 47. Average FWD deflection plot for both the control and heated slabs

The average heated-slab deflection is about 10% lower than for the control slabs, indicating that the heated slabs are stiffer with a higher modulus. BAKFAA 3.3.0 software (FAA 2020) was used for back-calculation, and the average back-calculated modulus values for the heated and control slabs were 5.5 million psi (38,000 million Pa) and 4.1 million psi (28,000 million Pa), respectively.

The average load transfer efficiency (LTE) was about 90% for both the heated and control slabs. It is worth mentioning that while the control slabs had 1.5 in. (3.81 cm) diameter dowel bars and the heated slabs had $\frac{3}{4}$ in. (1.9 cm) diameter dowel bars, this difference in dowel bar thickness did not result in any significant changes in the slab LTE value. In addition, no cracking was observed in the ECON HPS slabs after 3 years of monitoring. However, a crack was generated on a standard concrete pavement on the south side of the ECON HPS slabs after 1 year of construction. The ECON HPS slabs were located in a heavy loading area due to close proximity to the distribution center receiving line at the Iowa DOT.

7. SUMMARY, CONCLUSIONS, AND RECOMMENDATIONS

7.1. Conclusions

The objective of this study was to demonstrate the design, full-scale demonstration, and performance monitoring of the largest operational ECON HPS. Ten ECON HPS test slabs were designed and constructed at the south parking lot of the Iowa DOT headquarters in Ames, Iowa, during October 2018. A PLC system and slab instrumentation using temperature sensors were designed and implemented for remote-control operation and system performance monitoring. Deicing and anti-icing ECON HPS performance was evaluated during the 2018–2021 winter seasons.

The summarized findings of this study are as follows:

- Ten ECON HPS test slabs with various electrode configurations were constructed in the south parking lot of the Iowa DOT headquarters as the largest ECON HPS implementation project. All the test slabs showed promising snow- and ice-free capabilities during various winter weather events.
- Each ECON HPS test slab had a different electrode configuration in terms of electrode shape, size, and spacing. The flat bar, the 1.0 in. (2.5 cm) hollow bar, the 1.0 in. (2.5 cm) solid bar, and the 0.75 in. (1.9 cm) solid bar have the same trend that power density decreases when the number of electrodes increases. However, the flat bar has the highest and the 0.75 in. (1.9 cm) solid bar has the lowest power density among all the different spacing options.
- The power density range for all the slabs was between 10.2 W/ft² (109.8 W/m²) and 45.6 W/ft² (491.5 W/m²), with an average of 24.6 W/ft² (265.1 W/m²). The power density normalized to the resistivity of each ECON HPS slab ranged between 0.42 W/ft² (4.6 W/m²) (slab 8S-0.75) and 8.6 W/ft² (93.1 W/m²) (slab 8F-1).
- Increasing the electrode diameter in circular solid bars resulted in an increase in power density in all electrode spacing.
- The power density was decreased in the flat bar and 1.0 in. (2.5 cm) circular solid bar slabs by decreasing the electrode spacing (increasing the number of the electrodes used in each slab).
- Based on the theory, the laboratory studies, and the FE models, the temperature increase rate of an electrode is influenced by its surface contact area (perimeter).
- A theoretical formulation was developed to describe the ECON HPS thermal behavior.
- An increase in electrode size resulted in an increase in energy conversion efficiency.

- FWD testing showed that the average heated pavement deflections were about 10% lower than those of regular concrete pavement slabs, indicating that the heated slabs were stiffer with a higher modulus.
- The slope of the temperature increase rate versus the perimeter curve for different electrodes was found to be identical in both water and ECON prototype slab tests.
- Flat-bar orientation (vertical versus horizontal) did not significantly change the heating performance of the electrodes according to water tests.
- The PLC exhibited better control flexibility than Arduino board microcontrollers in terms of autonomous control, expandability, and control capability.

7.2. Recommendations for Implementation and Future Research Directions

The findings of this study facilitate the design of an ECON HPS and provide detailed information on the construction steps. The following recommendations have been drawn from this study to facilitate the design and construction of future ECON HPS implementations:

- A designed, programmed, and implemented PLC system was found to be a promising and robust remote-control system to be used in ECON HPS technology.
- Testing electrodes in water for monitoring the temperature increase rate is a faster, repeatable, nondestructive, and cost-effective method for identifying favorable electrode sizes and comparing electrode performance for an ECON HPS.
- Considering initial costs of the electrodes, flat-bar and smaller-diameter electrodes were found to be more cost-effective than the larger electrodes due to the lower cost of smaller-sized electrodes relative to the temperature increase rates associated with them.
- Use of 20% fly ash Class C replacement and removal of methylcellulose and DCI admixtures helped improve the slump to 3.9 in. (10 cm) during the Iowa DOT project ECON placement.
- If sensors are to be incorporated into the ECON HPS design, their tips and cables must be electrically insulated and thermally operational.
- Using multiple voltages with the PLC control device gave ECON HPS users control over snow- and ice-melting speed.
- Premature cracking due to the use of an angle-shaped electrode can be eliminated by incorporating circular or flat-bar electrode shapes.

- The paths followed by water produced as the result of melting ice and snow from the heated slabs to the drainage outlet must be heated to eliminate ice formation near the heated slabs.
- The best operational practice of heated pavements is to turn the system on before the snow event starts so that snow accumulation will not occur and operation time and consequent operation cost will decrease.

Other applications and the rationale for prioritization among critical areas of Iowa transportation infrastructure systems for ECON HPS implementations, identified as being of interest to the Iowa DOT and Iowa county and city engineers, are discussed as follows:

- **Bridge decks**

- Bridges are the first locations in a highway system to freeze during the winter season. Thin layers of black ice and frost form on top of the bridge deck, potentially resulting in vehicles sliding off the bridge and causing fatal crashes. Many highway agencies dedicate portions of their winter maintenance budget to deicing these locations (so-called frost-run operations) that help mitigate this hazard. Entrance and exit ramps on the highway system are also potential winter hazards due to higher vehicle speeds and the potential to slide off the ramp.
- Given these frost-run operations are typically on bridges located over a body of water, resulting in a direct chloride load into the water system, heated-bridge technology can mitigate direct chloride load into nearby water bodies.
- During this study, several highway agencies, such as those in Iowa and Wisconsin, have expressed strong interest in implementation of heated-bridge technology.

- **Rest areas**

- Rest areas, specifically on interstate highway systems, experience high foot traffic throughout the year, and they are typically located in areas that would not be easily accessible to winter maintenance crews to clear the snow and ice in a timely manner.
- ECON HPS technology is in full compliance with the Americans with Disabilities Act (ADA) mission to ease the commute of individuals with disabilities, especially during the winter season. Based on data from the U.S. Bureau of Labor Statistics, about 25% of ice- and snow-related falls occur in parking lots. Snow and ice can cause significant hardship for individuals with disabilities, and implementing heated pavement on parking lots and ramps could be a way to mitigate this hardship. In addition, the Iowa DOT has received dedicated funding for ADA-compliance projects that can be used to further implement ECON HPS, facilitating the contribution of people with disabilities to our society.

The versatility of the ECON HPS technology demonstrated for roadway application in this study is such that it can be custom-designed and optimized for each specific transportation infrastructure application depending on need and interest. This versatility stems from the fact that

the ECON HPS technology can be implemented as either a conductive concrete surface for a new construction project or a conductive concrete overlay on top of an existing structure for a rehabilitation project. However, the ECON HPS design requirements and considerations are somewhat different for each specific application, warranting detailed research investigations before being fully implemented in each situation. Therefore, pursuit of future research directions from this study is recommended to develop and implement custom-designed and optimized ECON HPS technology for each prioritized application area identified (i.e., bridge decks and rest areas).

REFERENCES

- Abdualla, H. 2018. *Design, Construction, and Performance of Heated Concrete Pavements System*. PhD dissertation. Iowa State University, Ames, IA.
<https://lib.dr.iastate.edu/cgi/viewcontent.cgi?article=7275&context=etd>.
- Abdualla, H., H. Ceylan, S. Kim, K. Gopalakrishnan, P. C. Taylor, and Y. Turkan. 2016. System Requirements for Electrically Conductive Concrete Heated Pavements. *Transportation Research Record: Journal of the Transportation Research Board*, No. 2569, pp. 70–79.
- Abdualla, H., H. Ceylan, S. Kim, M. Mina, K. S. Cetin, P. C. Taylor, K. Gopalakrishnan, B. Cetin, S. Yang, and A. Vidyadharan. 2018. Design and Construction of the World’s First Full-Scale Electrically Conductive Concrete Heated Airport Pavement System at a U.S. Airport. *Transportation Research Record: Journal of the Transportation Research Board*, Vol. 2672, No. 23, pp. 82–94.
- Abdualla, H., H. Ceylan, S. Kim, M. Mina, K. Gopalakrishnan, A. Sassani, P. C. Taylor, and K. S. Cetin. 2017. Configuration of Electrodes for Electrically Conductive Concrete Heated Pavement Systems. *Airfield and Highway Pavements 2017*, International Conference on Highway Pavements and Airfield Technology 2017, August 27–30, Philadelphia, PA, pp. 1–9.
- Alimohammadi, H. and B. Izadi Babokani. 2019. Finite Element Analysis of a Piezoelectric Layered Plate with Different Materials. *International Journal of Engineering and Applied Sciences (IJEAS)*, Vol. 6, No. 8, pp. 18–21.
- ANSYS, Inc. 2018. Ansys software.
- Arabzadeh, A., H. Ceylan, S. Kim, K. Gopalakrishnan, A. Sassani, S. Sundararajan, P. C. Taylor, and A. Abdullah, A. 2017a. Influence of Deicing Salts on the Water-Repellency of Portland Cement Concrete Coated with Polytetrafluoroethylene and Polyetheretherketone. *Airfield and Highway Pavements 2017*, International Conference on Highway Pavements and Airfield Technology 2017, August 27–30, Philadelphia, PA, pp. 217–227.
- Arabzadeh, A., H. Ceylan, S. Kim, K. Gopalakrishnan, A. Sassani, S. Sundararajan, and P. C. Taylor. 2017b. Superhydrophobic Coatings on Portland Cement Concrete Surfaces. *Construction and Building Materials*, Vol. 141, pp. 393–401.
- Arabzadeh, A., H. Ceylan, S. Kim, A. Sassani, and K. Gopalakrishnan. 2018. Investigating the Heat Generation Efficiency of Electrically-Conductive Asphalt Mastic Using Infrared Thermal Imaging. *International Conference on Transportation and Development 2018*, July 15–18, Pittsburgh, PA, pp. 206–214.
- Arabzadeh, A., M. A. Notani, A. Kazemiyani Zadeh, A. Nahvi, A. Sassani, and H. Ceylan. 2019. Electrically Conductive Asphalt Concrete: An Alternative for Automating the Winter Maintenance Operations of Transportation Infrastructure. *Composites Part B: Engineering*, Vol. 173, Article no. 106985, pp. 1–13.
- ASHRAE. 2009. Snow Melting and Freeze Protection. *ASHRAE Handbook: Fundamentals*. American Society of Heating, Refrigerating, and Air-Conditioning Engineers, Atlanta, GA.
- ASTM A240/A240M. 2017. *Standard Specification for Chromium and Chromium-Nickel Stainless Steel Plate, Sheet, and Strip for Pressure Vessels and for General Applications*. ASTM International, West Conshohocken, PA.

- ASTM A66-15. 2015. *Standard Specification for Annealed or Cold-Worked Austenitic Stainless Steel Sheet, Strip, Plate, and Flat Bar*. ASTM International, West Conshohocken, PA.
- Baskas, H. 2011. Winter Survival Strategies from the USA's Snowiest Airports. *USA Today*.
- Bolen, W. P. 2020. Salt. *U.S. Geological Survey Mineral Commodity Summaries*, pp. 138–139.
- Ceylan, H., K. Gopalakrishnan, S. Kim, and W. Cord. 2014. *Heated Transportation Infrastructure Systems: Existing and Emerging Technologies*. 12th International Symposium on Concrete Roads, September 23–26, Prague, Czech Republic. https://lib.dr.iastate.edu/cgi/viewcontent.cgi?article=1018&context=ccee_conf.
- Chen, W. and P. Gao. 2012. Performances of Electrically Conductive Concrete with Layered Stainless Steel Fibers. *Sustainable Construction Materials 2012*, Second International Conference on Sustainable Construction Materials: Design, Performance, and Application, October 18–22, Wuhan, China, pp. 164–172.
- Farnam, Y., M. Krafcik, L. Liston, T. Washington, K. Erk, B. Tao, and J. Weiss. 2016. Evaluating the Use of Phase Change Materials in Concrete Pavement to Melt Ice and Snow. *Journal of Materials in Civil Engineering*, Vol. 28, No. 4, Article no. 04015161.
- FAA. 2020. Airport Safety Detail. BAKFAA 3.3.0. Federal Aviation Administration. <https://www.airporttech.tc.faa.gov/Products/Airport-Safety-Papers-Publications/Airport-Safety-Detail/ArtMID/3682/ArticleID/11/BAKFAA-version-2101>.
- FHWA. 2017. FHWA Road Weather Management, How Do Weather Events Impact Roads? Federal Highway Administration. https://ops.fhwa.dot.gov/weather/q1_roadimpact.htm.
- Forintos, N. and T. Czigany. 2019. Multifunctional Application of Carbon Fiber Reinforced Polymer Composites: Electrical Properties of the Reinforcing Carbon Fibers – A Short Review. *Composites Part B: Engineering*, Vol. 162, pp. 331–343.
- Gomis, J., O. Galao, V. Gomis, E. Zornoza, and P. Garcés. 2015. Self-Heating and Deicing Conductive Cement. Experimental Study and Modeling. *Construction and Building Materials*, Vol. 75, pp. 442–449.
- Gong, T., S. P. Peng, R. Y. Bao, W. Yang, B. H. Xie, and M. B. Yang. 2016. Low Percolation Threshold and Balanced Electrical and Mechanical Performances in Polypropylene/Carbon Black Composites with a Continuous Segregated Structure. *Composites Part B: Engineering*, Vol. 99, pp. 348–357.
- Gopalakrishnan, K., H. Ceylan, S. Kim, S. Yang, and H. Abdualla. 2015. Electrically Conductive Mortar Characterization for Self-Heating Airfield Concrete Pavement Mix Design. *International Journal of Pavement Research and Technology*, Vol. 8, No. 5, pp. 315–324.
- Guo, S., R. Si, Q. Dai, Z. You, Y. Ma, and J. Wang. 2019. A Critical Review of Corrosion Development and Rust Removal Techniques on the Structural/Environmental Performance of Corroded Steel Bridges. *Journal of Cleaner Production*, Vol. 233, pp. 126–146.
- Habibzadeh-Bigdarvish, O., X. Yu, G. Lei, T. Li, and A. J. Puppala. 2019. Life-Cycle Cost-Benefit Analysis of Bridge Deck De-Icing Using Geothermal Heat Pump System: A Case Study of North Texas. *Sustainable Cities and Society*, Vol. 47, Article no. 101492, pp. 1–13.
- Heymsfield, E., A. B. Osweiler, R. P. Selvam, and M. Kuss. 2013. *Feasibility of Anti-Icing Airfield Pavements Using Conductive Concrete and Renewable Solar Energy*. Federal Aviation Administration, Washington, DC.

- Ho, C. Y., and T. K. Chu. 1977. *Electrical Resistivity and Thermal Conductivity of Nine Selected AISI Stainless Steels*. Thermophysical and Electronic Properties Information Analysis Center, Center for Information and Numerical Data Analysis and Synthesis, Purdue University, West Lafayette, IN.
- Hou, Z., Z. Li, and J. Wang. 2007. Electrical Conductivity of the Carbon Fiber Conductive Concrete. *Journal of Wuhan University of Technology-Material Science Edition*, Vol. 22, No. 2, pp. 346–349.
- Iowa DOT. n.d. *Iowa DOT Standard Specification with GS-15008 Revisions*. Iowa Department of Transportation, Ames, IA.
- IEM. 2019. ASOS Network, ASOS-AWOS-METAR Data Download. Iowa Environmental Mesonet, Iowa State University, Ames, IA.
https://mesonet.agron.iastate.edu/request/download.phtml?network=TX_ASOS.
- Jamil, A., S. Riaz, M. Ashraf, and M. R. Foolad. 2011. Gene Expression Profiling of Plants Under Salt Stress. *Critical Reviews in Plant Sciences*, Vol. 30, No. 5, pp. 435–458.
- Kim, M., D. H. Sung, K. Kong, N. Kim, B.-J. Kim, H. W. Park, Y.-B. Park, M. Jung, S. H. Lee, and S. G. Kim. 2016. Characterization of Resistive Heating and Thermoelectric Behavior of Discontinuous Carbon Fiber-Epoxy Composites. *Composites Part B: Engineering*, Vol. 90, pp. 37–44.
- De Langhe, K., E. Struyf, C. Sys, E. Van de Voorde, and T. Vanelslander. 2013. Economic Effects of a Temporary Shutdown of an Airport - Review and Case Study. *Proceedings of the WCTR 2013 Conference, the 13th World Conference on Transport Research*, Rio de Janeiro, Brazil, pp. 1–31.
- Liang, J. Z. and Q. Q. Yang. 2017. Effects of Carbon Fiber Content and Size on Electric Conductive Properties of Reinforced High Density Polyethylene Composites. *Composites Part B: Engineering*, Vol. 114, pp. 457–466.
- Liu, T. J.-C. 2017. Numerical Analysis of Joule Heating Behavior and Residual Compressive Stress around Crack Tip under High Electric Load. *Modelling and Simulation in Engineering*, Vol. 2017, pp. 1–9.
- Malakooti, A. 2017. *Investigation of Concrete Electrical Resistivity As a Performance Based Test*. MS thesis. Utah State University, Logan, UT.
- Malakooti, A., M. Maguire, and R. J. Thomas. 2018. *Evaluating Electrical Resistivity as a Performance Based Test for Utah Bridge Deck Concrete*. Center for Advanced Infrastructure and Transportation, Rutgers, The State University of New Jersey, Piscataway, NJ.
- Malakooti, A., R. J. Thomas, and M. Maguire. 2019. *Investigation of Concrete Electrical Resistivity As a Performance Based Test*. Utah State University, Logan, UT.
- Malakooti, A., W. S. Theh, S. Sadati, H. Ceylan, S. Kim, M. Mina, K. Cetin, and P. C. Taylor. 2020. Design and Full-Scale Implementation of the Largest Operational Electrically Conductive Concrete Heated Pavement System. *Construction and Building Materials*, Vol. 255, Article no. 119229, pp. 1–11.
- Malakooti, A., H. Abdulla, S. Sadati, H. Ceylan, S. Kim, and K. Cetin. 2021. Experimental and Theoretical Characterization of Electrodes on Electrical and Thermal Performance of Electrically Conductive Concrete. *Composites Part B: Engineering*, Article no. 109003, pp. 1–12.

- Melugiri-Shankaramurthy, B., Y. Sargam, X. Zhang, W. Sun, K. Wang, and H. Qin. 2019. Evaluation of Cement Paste Containing Recycled Stainless Steel Powder for Sustainable Additive Manufacturing. *Construction and Building Materials*, Vol. 227, Article no. 116696, pp. 1–9.
- Mosavi, H., R. Alrashidi, M. Almarshoud, M. H. Alyami, K. A. Riding, C. C. Ferraro, M. D. A. Thomas, and H. DeFord. 2020. Use of Electrical Test Method on Determination Aging Factor of Concrete Incorporating Supplementary Cementitious Materials. *Proceedings of the International Conference of Sustainable Production and Use of Cement and Concrete*, pp. 299–306.
- Nahvi, A., S. Sadati, K. Cetin, H. Ceylan, A. Sassani, and S. Kim. 2018. Towards Resilient Infrastructure Systems for Winter Weather Events: Integrated Stochastic Economic Evaluation of Electrically Conductive Heated Airfield Pavements. *Sustainable Cities and Society*, Vol. 41, pp. 195–204.
- Nguyen, D.-L., M. Ngoc-Tra Lam, D.-J. Kim, and J. Song. 2020. Direct Tensile Self-Sensing and Fracture Energy of Steel-Fiber-Reinforced Concretes. *Composites Part B: Engineering*, Vol. 183, Article no. 107714, pp. 1–19.
- Notani, M. A., A. Arabzadeh, H. Ceylan, S. Kim, and K. Gopalakrishnan. 2019. Effect of Carbon-Fiber Properties on Volumetrics and Ohmic Heating of Electrically Conductive Asphalt Concrete. *Journal of Materials in Civil Engineering*, Vol. 31, No. 9.
- O'Donnell, M. J. 2008. *Airport Winter Safety and Operations*. Advisory Circular AC 150/5200-30C. Federal Aviation Administration, Washington, DC.
- Rao, R., J. Fu, Y. Chan, C. Y. Tuan, and C. Liu. 2018. Steel Fiber Confined Graphite Concrete for Pavement Deicing. *Composites Part B: Engineering*, Vol. 155, pp. 187–196.
- Rao, R., H. Wang, H. Wang, C. Y. Tuan, and M. Ye. 2019. Models for Estimating the Thermal Properties of Electric Heating Concrete Containing Steel Fiber and Graphite. *Composites Part B: Engineering*, Vol. 164, pp. 116–120.
- Ravindren, R., S. Mondal, K. Nath, and N. C. Das. 2019. Prediction of Electrical Conductivity, Double Percolation Limit and Electromagnetic Interference Shielding Effectiveness of Copper Nanowire Filled Flexible Polymer Blend Nanocomposites. *Composites Part B: Engineering*, Vol. 164, pp. 559–569.
- Sadati, S., K. Cetin, and H. Ceylan. 2017. Numerical Modeling of Electrically Conductive Pavement Systems. *Congress on Technical Advancement 2017*, 17th International Conference on Cold Regions Engineering, September 10–13, Duluth, MN, pp. 111–120.
- Sadati, S., K. Cetin, H. Ceylan, A. Sassani, and S. Kim. 2018. Energy and Thermal Performance Evaluation of an Automated Snow and Ice Removal System at Airports Using Numerical Modeling and Field Measurements. *Sustainable Cities and Society*, Vol. 43, pp. 238–250.
- Sadati, S., K. S. Cetin, H. Ceylan, and S. Kim. 2019. *A Methodology for Investigating Different Electrode Design Configurations of Electrically Conductive Concrete Heated Pavement Systems*. 98th Transportation Research Board Annual Meeting, January 13–17, Washington, DC.
- Sadati, S., K. S. Cetin, H. Ceylan, and S. Kim. 2020a. Energy-Efficient Design of a Carbon Fiber-Based Self-Heating Concrete Pavement System through Finite Element Analysis. *Clean Technologies and Environmental Policy*, Vol. 22, pp. 1145–1155.

- Sadati, S., A. Malakooti, K. S. Cetin, H. Ceylan, and S. Kim. 2020b. Proposed Improvements to the Construction of Electrically Conductive Concrete Pavement System Based on Lessons Learned. *Construction Research Congress 2020: Project Management and Controls, Materials, and Contracts*, March 8–10, Tempe, AZ, pp. 1049–1056.
- Sassani, A., H. Ceylan, S. Kim, K. Gopalakrishnan, A. Arabzadeh, and P. C. Taylor. 2017. Influence of Mix Design Variables on Engineering Properties of Carbon Fiber-Modified Electrically Conductive Concrete. *Construction and Building Materials*, Vol. 152, pp. 168–181.
- Sassani, A., A. Arabzadeh, H. Ceylan, S. Kim, S. Sadati, K. Gopalakrishnan, P. C. Taylor, and H. Abdualla. 2018a. Carbon Fiber-Based Electrically Conductive Concrete for Salt-Free Deicing of Pavements. *Journal of Cleaner Production*, Vol. 203, pp. 799–809.
- Sassani, A., H. Ceylan, S. Kim, A. Arabzadeh, P. C. Taylor, and K. Gopalakrishnan. 2018b. Development of Carbon Fiber-Modified Electrically Conductive Concrete for Implementation in Des Moines International Airport. *Case Studies in Construction Materials*, Vol. 8, pp. 277–291.
- Thurston, R. E., G. Culver, and J. W. Lund. 1995. Pavement Snow Melting in Klamath Falls - Rehabilitation of the ODOT Well. *Geo-Heat Center Quarterly Bulletin*, Vol. 16, No. 2.
- Tian, X. and H. Hu. 2012. Test and Study on Electrical Property of Conductive Concrete. *Procedia Earth and Planetary Science*, Vol. 5, pp. 83–87.
- Tian, Z., Y. Li, J. Zheng, and S. Wang. 2019. A State-of-the-Art on Self-Sensing Concrete: Materials, Fabrication and Properties. *Composites Part B: Engineering*, Vol. 177, Article no. 107437, pp. 1–17.
- Whittington, H. W., J. McCarter, and M. C. Forde. 1981. The Conduction of Electricity Through Concrete. *Magazine of Concrete Research*, Vol. 33, No. 114, pp. 48–60.
- Wu, J., J. Liu, and F. Yang. 2014. *Study on Three-Phase Composite Conductive Concrete for Pavement Deicing*. Transportation Research Board 93rd Annual Meeting, January 12–16, Washington, DC.
- Xi, Y. and P. J. Olsgard. 2000. Effects of De-Icing Agents (Magnesium Chloride and Sodium Chloride) on Corrosion of Truck Components. Colorado Department of Transportation Research Branch, Denver, CO.
- Xie, P. and J. J. Beaudoin. 1995. Electrically Conductive Concrete and Its Application in Deicing. *Proceedings of the Second Canadian Centre for Mineral and Energy Technology (CANMET)/American Concrete Institute (ACI) International Symposium*, Vol. 154, pp. 399–418.
- Zhang, W., Q. Zheng, A. Ashour, and B. Han. 2020. Self-Healing Cement Concrete Composites for Resilient Infrastructures: A Review. *Composites Part B: Engineering*, Vol. 189, Article no. 107892, pp. 1–28.

APPENDIX A. DRAFT STANDARD SPECIFICATION FOR ECON HPS CONSTRUCTION AT THE IOWA DOT SOUTH PARKING LOT

A.1. Description

An electrically conductive concrete (ECON) heated pavement system (HPS) functions by applying an electric current through electrodes embedded in a top-layer ECON layer (Figure A-1).

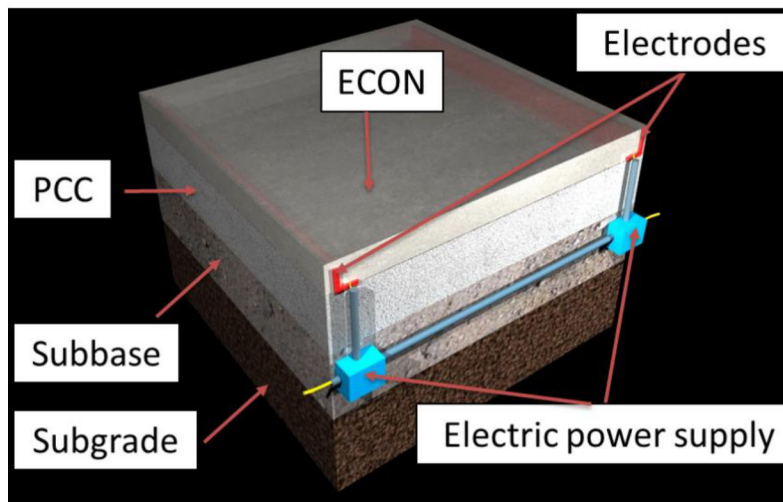

Figure A-1. Conceptual design of ECON HPS

Because it has lower electrical resistivity than normal concrete, ECON behaves like a conductor of electricity. The main components of the ECON HPS include conductive materials (heating elements) for ECON, electrodes, a power supply, and temperature sensors.

The proposed ECON HPS structure for the Iowa Department of Transportation (DOT) headquarters south parking lot construction project consists of four layers: 3.0 in. (7.6 cm) layer of ECON containing embedded electrodes on top of a 7.0 in. (17.8 cm) layer of portland cement concrete (PCC), comprising a 10.0 in. (25.4 cm) thick combined PCC layer, an aggregate base course, and the subgrade. Type and class of each pavement layer in an ECON HPS is specified in the contract. Additional details on each element are given as follows:

A. PCC: Standard Concrete Pavement

Standard concrete pavement, reinforced or non-reinforced, can be utilized as the bottom layer in ECON HPS. Use the class of concrete specified in the contract documents. Reinforce as shown in the contract documents. Place within fixed forms, consolidate, and finish by equipment operating on forms.

B. PCC: Slip-Form Concrete Pavement

Slip-form concrete pavement can be utilized as a bottom layer in an ECON HPS. It may be

reinforced or non-reinforced concrete of the class specified in the contract documents. Reinforce as shown in the contract documents. Place, consolidate, and finish without the use of fixed forms.

C. ECON

ECON is a cementitious mixture containing a certain amount of electrically conductive components in standard concrete, which is designed for pavement to serve as the heat source when electrical energy is applied. The general constituents of ECON are cement, aggregates, water, electrically conductive additives (ECAs), and possibly admixtures. ECON can be utilized as a top layer in an ECON HPS. An ECON layer requires the installation of electrodes to provide electric power to the ECON HPS for generating heat. In addition to electrodes, it may be reinforced or non-reinforced using fiberglass reinforcing steel bars or alternatives. Place, consolidate, and finish with the use of fixed forms or slip form. Reinforcement and paving type (i.e., fixed form or slip form) as are applied shown in the contract documents. Additional details on the pavement materials are given as follows:

A.2. Pavement Materials

A. PCC Layer (Bottom Layer)

Meet the requirements for the respective items in “Division 41. Construction Materials” and “Section 2301. Portland Cement Concrete Pavement” in the Iowa DOT Standard Specifications.

B. ECON Layer (Top Surface Layer)

1. General

ECON should meet the general requirements of “Section 2301. Portland Cement Concrete Pavement” in the Iowa DOT Standard Specifications unless items are specified by the engineer. Given the consistency and workability of carbon fiber-reinforced concrete is different from an equivalent standard concrete, adjustments to aggregate gradations and cement paste to aggregate ratio are required to obtain desirable fresh and hardened properties.

2. Electrically Conductive Additives (ECAs)

Carbon fiber with a nominal length of 0.25 in. (6 mm) and a diameter of 7 μm in dosages less than 1.25% by total volume of concrete can be used as an ECA.

3. Combined Fine and Coarse Aggregate

Fine and coarse aggregate proportions are determined to obtain required concrete workability to meet consistency requirements of “Section 2301. Portland Cement Concrete Pavement” and gradation requirements for individual aggregates in “Section 4109. Aggregate Gradations” in the Iowa DOT Standard Specifications.

4. **Water, Consistency, and Batch Yield**

Water/cementitious materials ratio, consistency, and batch yield should conform to “Section 2301. Portland Cement Concrete Pavement” in the Iowa DOT Standard Specifications.

5. **Entrained-Air Content**

Conformance with the entrained-air content requirement in “Section 2301. Portland Cement Concrete Pavement” in the Iowa DOT Standard Specifications.

6. **Admixtures**

Air entraining, water-reducing admixture, and set-retarding admixtures were used in accordance to “Section 4103. Liquid Admixtures for Portland Cement Concrete” in “Division 41. Construction Materials” of the Iowa DOT Standard Specifications. Corrosion inhibitor admixture (e.g., DCI admixture manufactured by GCP Applied Technologies) can only be used as a conductivity-enhancing agent based on its compatibility with other admixtures.

7. **Use of Supplementary Cementitious Materials**

Class F fly ash that meets the requirements of “Section 4108. Supplementary Cementitious Materials” in “Division 41. Construction Materials” of the Iowa DOT Standard Specifications.

8. **Proportioning and Mixing of Concrete Materials**

a. **Storage and Handling of Aggregates**

Should be practiced according to “Section 2301. Portland Cement Concrete Pavement” in the Iowa DOT Standard Specifications.

b. **Storage and Handling of Cement and Fly Ash**

Should be practiced according to “Section 2301. Portland Cement Concrete Pavement” in the Iowa DOT Standard Specifications.

c. **Measurement of Materials**

Should conform to “Section 2301 Portland Cement Concrete Pavement” practice in the Iowa DOT Standard Specifications. In addition, the engineer independently tested the materials and verified the results given by the contractor two weeks prior to concrete placement.

d. **Mixing of Materials**

Carbon fiber should be fed into the concrete mixer along with fine and coarse aggregate and dry-mixed for 30 seconds before addition of water and cement. A portion of the water (10–20 gallons) should be added at the job site and mixed for an adequate length of time. To prevent excessive fiber wear by aggregates, the entire mixing procedure (the sum of the mixing time in the concrete plant and truck mixer)

should not take longer than 15 minutes. Preconstruction training and pretrial quality control tests of an ECON trial batch produced from the concrete plant is recommended at least 14 days before paving at the job site.

A.3. Construction

When the contract allows for either standard or slip-form pavement, the method used is the contractor's option. When the contract allows only one type, use the type specified. When slip-form is specified, small or irregular areas may be constructed with fixed forms. Irregularly shaped areas of either type of pavement may be formed and finished by hand methods. The construction steps are given as follows:

A. General: Construction Procedures

Part of the construction procedure of the ECON slabs is shown in Figure A-2.



Figure A-2. ECON construction procedure

The construction sequence of the ECON HPS involves the following major steps:

- Step 1: Prepare the subgrade and base layer
- Step 2: Install dowel baskets and tie bars
- Step 3: Place polyvinyl chloride (PVC) conduits to house wires for sensors and power lines for electrodes
- Step 3: Place PCC layer as the bottom layer
- Step 4: Place electrode and sensor systems
- Step 5: Connect electrical wires for electrodes to an alternating current (AC) power supply and connect sensor wires to data acquisition systems
- Step 6: Place fiberglass on top of the electrodes
- Step 5: Clean the surface of the PCC layer and the electrodes
- Step 6: Place ECON layer as the top surface layer

B. Base and Subgrade Preparation

Meet the requirements for the respective items in “Division 21. Earthwork, Subgrades, and Subbases;” “Division 22. Base Course;” and “Section 2301. Portland Cement Concrete Pavement” in the Iowa DOT Standard Specifications.

C. Install Dowel Baskets and Tie Bars

Meet the requirements for these items in “Section 2301. Portland Cement Concrete Pavement” in Iowa DOT Standard Specifications. The dowel baskets and tie bars should also be covered by a PCC layer (bottom layer) so that electrodes can be easily installed on top of the surface of the PCC layer.

D. PVC Conduit Installation

Installation should be practiced according to “Section 2523. Highway Lighting” in the Iowa DOT Standard Specifications. PVC conduits should be used to protect and house the wires for electrodes and sensors. To prevent interference between sensor signals, the electrical wires of the electrodes should be placed into separate conduits. PVC conduits and junction boxes should be installed to support placing wires through the conduits.

E. PCC Layer (Bottom Layer)

Meet the requirements for the PCC layer in “Section 2301. Portland Cement Concrete Pavement” in the Iowa DOT Standard Specifications. In addition, the surface of the PCC layer should be screeded or roughened using brooms to create a rough surface or grooved to enhance the bond between the hardened PCC layer (bottom layer) and the later-placed ECON layer (top layer) (Figure A-3).

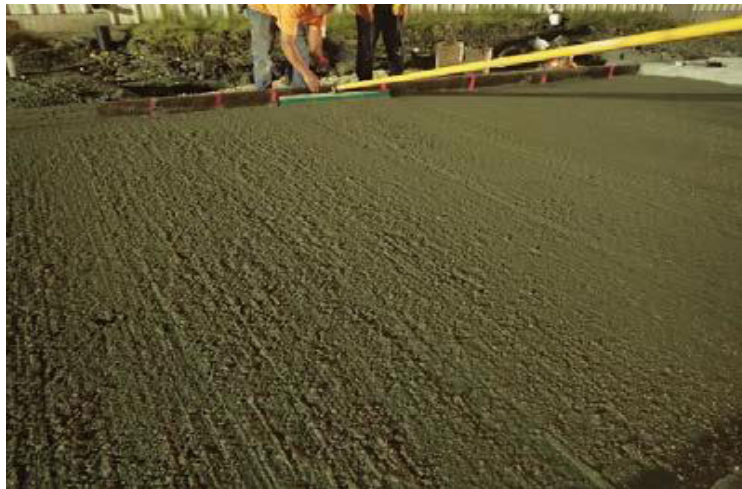

Figure A-3. Broom or screed PCC surface

F. ECON Layer (Top Surface Layer)

Meet the requirements for the ECON layer in “Section 2301. Portland Cement Concrete Pavement” in the Iowa DOT Standard Specifications. These items include electrode installation, sensor installation, electrical connections for electrodes, fiberglass installation (if

needed), cleaning the surface of the PCC layer (bottom layer), and placing the ECON layer (top surface layer). Preconstruction training and pretrial quality control tests of ECON trial batch produced from the concrete plant are recommended at least 14 days before the paving at the job site. The final product and all the ingredients should meet the Iowa DOT Standard Specifications.

1. Electrode Installation

Stainless steel 316L smooth electrodes (Figure A-4) are recommended as the electrode material. Given it is highly resistant to corrosion and given it can allow ECON to contract and expand with less resistance, it would not present any cracking potential.

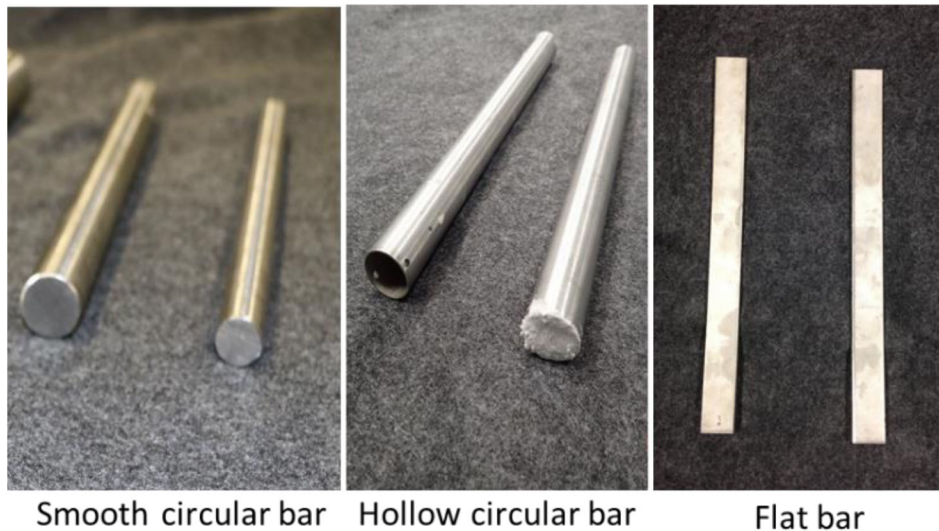

Figure A-4. Stainless steel 316L smooth electrodes

Nylon materials could be used to anchor and fix the electrodes to prevent movement during ECON layer placement because of its resistance to corrosion and its insulating properties that prevent current leakage into the ground. Given the electrodes should be anchored to the PCC layer, an electric drill should be used to drill holes in the PCC layer. Anchors should be placed in the holes to fix the electrodes, after which electrical wires to provide power to the system should be connected to the electrodes using gauge-ring wire connectors. Spacers can be used to bring electrodes closer to the surface and increase the efficiency of heat generation.

2. Sensor System Installation

Temperature sensors can be used for measuring temperature and for activating the ECON HPS power manually or automatically. Current and voltage sensors (e.g., wireless electricity-monitoring sensors manufactured by Monnit) can also be employed to monitor the electrical properties for estimating power consumption and operation cost.

3. Electrical Connections for Electrodes

Should conform in practice to “Section 2523. Highway Lighting” in the Iowa DOT

Standard Specifications. Electrodes should be connected to the AC power source. The ECON electric power supply system should be tested to check the wiring connections to the electrodes before placing the ECON layer. The electrical works required are described in more detail in “4 Electrical Works for Power Supply Management and Operation Control Systems” of this specification.

4. Clean the Surface of the PCC Layer

The contractor should thoroughly clean the surface of the bottom PCC layer and the electrodes, using an air blower, brooms, and a pressure washer to provide sufficient bonding between the electrodes and the ECON layer.

5. Placing ECON Layer

Meet the requirements for the ECON layer in “Section 2301. Portland Cement Concrete Pavement” in the Iowa DOT Standard Specifications. In addition, caution should be taken during the placement of the ECON layer to prevent damage to the electrode and sensor systems.

A.4. Electrical Works for Power Supply Management and Operation Control Systems

The following steps describe the required power supply and operation control management:

A. Design of Power Supply Management and Operation Control Systems

An electrical power source should be identified for designing power supply management and operation control systems. Assuming construction and operation of 10 ECON slabs, three-phase 208 volt alternating current (VAC) would be appropriate. The 10 ECON slabs are grouped into three separate zones, each tied to a single phase of the source to better distribute the power going through the slabs. An industrial-standard programmable logic controller (PLC) system can be used as the control system. The PLC central processing unit (CPU) (Automation Direct D4-440) requires a conveniently available 120–240 VAC source (a common household power outlet has a rating of 110 V), because it has low power consumption, allowing the CPU to tap power from the source intended primarily for the ECON slabs as an option if necessary. The cost of this model is another advantage; the alternative CPU requires a volt direct current (VDC) source and is more expensive.

In addition to the CPU, other peripherals and parts required for the system to be functional are as follows:

- Electrically erasable programmable read-only memory (EEPROM) cartridge to store ladder logic (programming codes)
- Output module to send on/off signals to relays
- Relays (one for each slab) to control connections between sources and wires to electrodes based on signals from the output module
- Input/Output (I/O) base to hook onto the modules

- Communication module to connect the PLC system to the internet for remote-access purposes

In addition to the parts mentioned previously, several other accessories are also needed including the following:

- Programming cable
- Serial adapter
- Pin connectors

The PLC system functions by sending signals to the relays. There are two sides of each relay: INPUT and LOAD. The INPUT pins are connected to the output module and common of the same module. The INPUT side detects the type of signal sent, either high (1) or low (0), and controls the connector built into the LOAD side. The LOAD pins are connected to the sources and the wires to the electrodes embedded into the ECON slabs. When INPUT detects a high signal, the LOAD is connected and current can flow from the source to the electrodes, then through the conductive ECON slabs into the grounded alternate electrodes (connected to neutral line of the source) to form a complete circuit.

B. Electrical Works Procedures

Step 1*: Connect alternate electrodes into a ground conduit to be connected to the neutral line of the power source

Step 2*: Connect remaining electrodes to wires pulled to the designated PLC system setup location

Step 3: Install PLC hardware into panel with clear and consistent labeling for relays

Step 4: Connect PLC hardware together based on user manual from the manufacturer

Step 5: Connect output module and common pins from PLC to INPUT pins on relays

Step 6: Connect source and wires to electrodes to LOAD pins on relays

Step 7: Conduct safety check on PLC system

Step 8: System startup and upload programming code

Step 9: Run initial test

* These steps should be done before placing the ECON layer

APPENDIX B. ECON HPS APPROVAL PROCESS SUMMARY

The approval process for the electrically conductive concrete (ECON) heated pavement system (HPS) in this project consisted of two parts: (1) wiring from the utility line to circuit breakers that had been wired by the Iowa Department of Transportation (DOT) electricians and (2) control system and wire distribution to each slab performed by the Iowa State University (ISU) research team. The first part approval was granted to the project but only conditional operation was granted for the second part.

On February 02, 2019, the slabs were turned on in the presence of a state electrical inspector, electrical safety tests were performed on the slabs, and the slabs were found to be in a safe condition. Some of the slabs relays were experiencing overheating due to high conductivity of the slabs, and the state electrical inspector allowed the ISU team to turn on the slabs to fix any possible bugs in the system.

After the first visit by the state inspector, the ISU research team made the following list of modifications in the electrical system, and they were completed by November 2019:

- To address the unbalanced load on the circuit breakers, the 208 volt alternating current (VAC) source was changed to 120 VAC:
 - The system worked with 120 VAC, and the maximum current through each breaker was less than 40 Amps
- To provide better heat transfer and dissipate heat from the relays:
 - Relays were removed from wooden plates and installed on steel plates (The heated wooden plates smelled during inspector's first visit, so they were replaced by steel plates)
 - Cooling fans were installed on the box covers to constantly blow on the relays
 - The maximum temperature reached by the relays is currently about 131°F [55°C] (The allowable working temperature for these relays is 194°F [90°C])
 - Figure B-1 shows the modified boxes and the installed fans on the relays
- A surveillance camera was installed, which allowed monitoring the system continuously



Figure B-1. Modification to address the overheating of relays

On November 14, 2019, Dave Millard, a professional engineer (PE) in electrical engineering from the Millard Engineering firm, visited the heated pavement site at the Iowa DOT headquarters and provided a letter regarding the wiring of the second part of the project, performed by the ISU research team (Figure B-2), stating that the system was constructed “in accordance with the National Electrical Code.”

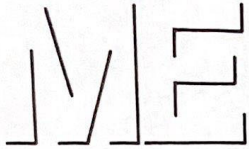

MILLARD ENGINEERING
1501 GLENDALE AVENUE

AMES, IOWA 50010

DAVID MILLARD, P.E.
515-232-6597

November 25, 2019

Mr. Halil Ceylan, Professor, CCEE
410 Town Engineering Bldg.
Iowa State University
813 Bissell Road
Ames, IA 50011-1066

RE: IDOT Heated Concrete Project

Dear Mr. Ceylan:

On November 14, 2019, I visited the site of the heated concrete research project at the Iowa Department of Transportation parking lot to inspect the electrical installation in the control building. I reviewed the system drawings and observed the construction of the control system. It was my observation that the system was constructed in accordance with commonly accepted control panel construction practices and in accordance with the National Electrical Code. It is acceptable for automatic/remote control operation.

Please contact me if you have any questions or comments.

Sincerely,

MILLARD ENGINEERING

David Millard, PE
Iowa License Number 9181

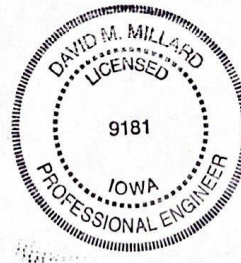

electrical and process control engineering, illumination engineering, water supply and wastewater treatment engineering

Figure B-2. Letter from a PE in electrical engineering regarding the wiring at Iowa DOT ECON HPS

APPENDIX C. DRAFT USER MANUAL FOR IOWA DOT ECON HPS

This is a step-by-step set of instructions for running the electrically conductive concrete (ECON) heated pavement system (HPS) system at the Iowa Department of Transportation (DOT). The seven steps are as follows:

Step 1: Place the status mode on the programmable logic controller (PLC) device itself to TERM and connect the USB cable to the computer.

Step 2: Left double click on DSLaunch 6 software.

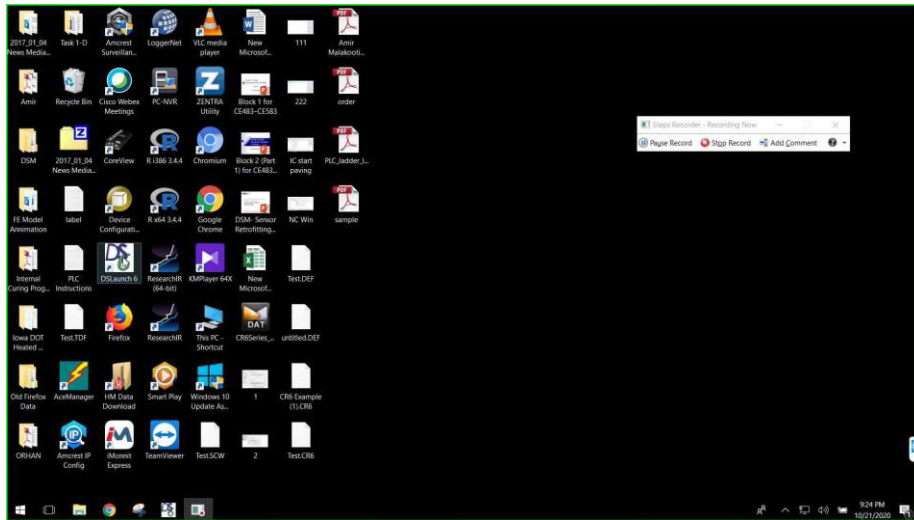

Figure C-1. Step 2 screenshot

Step 3: Left double click on ia_dot_dual.prj in DSLaunch.

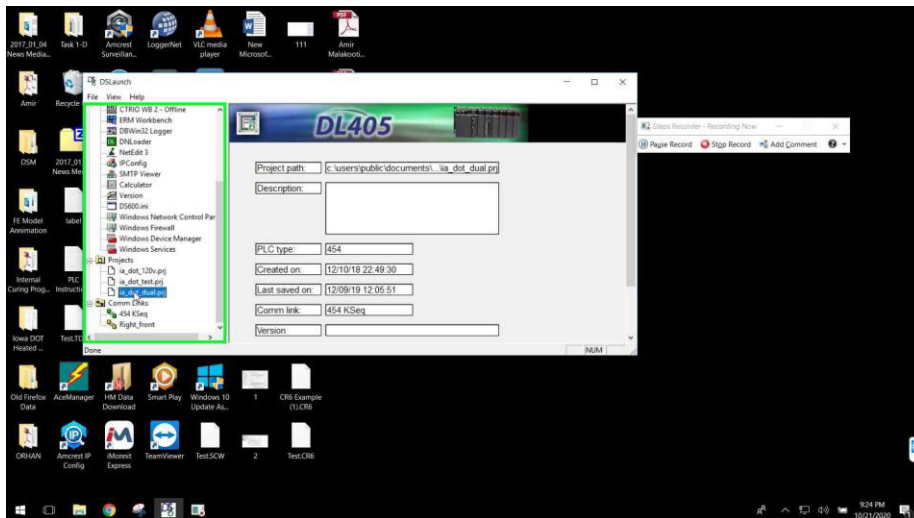

Figure C-2. Step 3 screenshot

Step 4: Left click on Mode in DirectSOFT 6 Programming - ia_dot_dual.

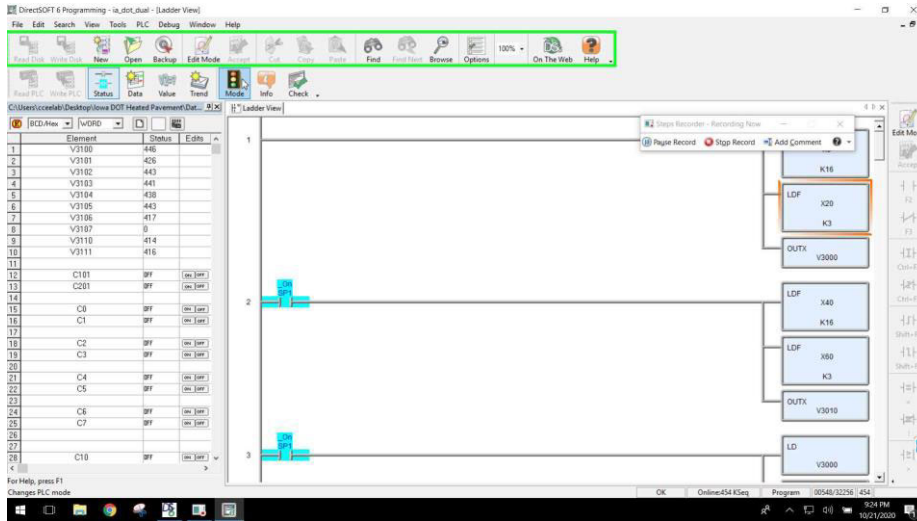

Figure C-3. Step 4 screenshot

Step 5: The PLC Modes windows will appear.

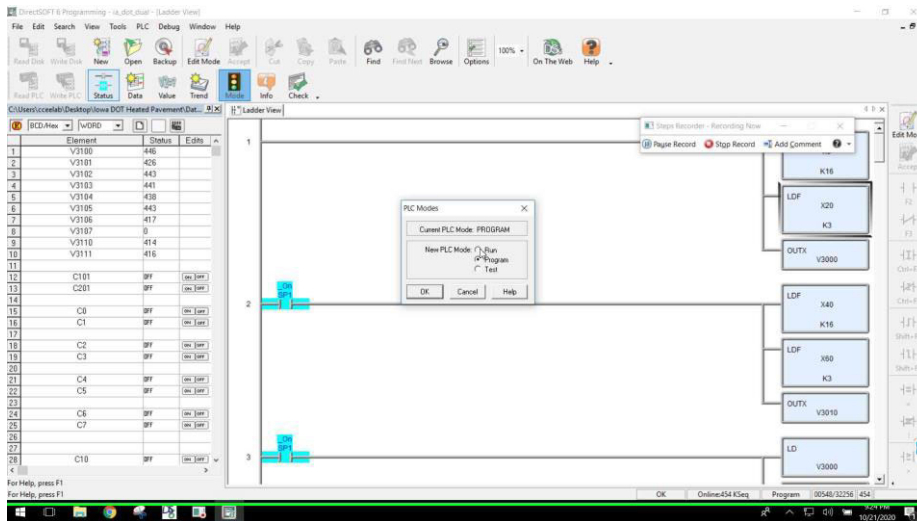

Figure C-4. Step 5 screenshot

Step 6: Choose Run mode, and click the OK button.

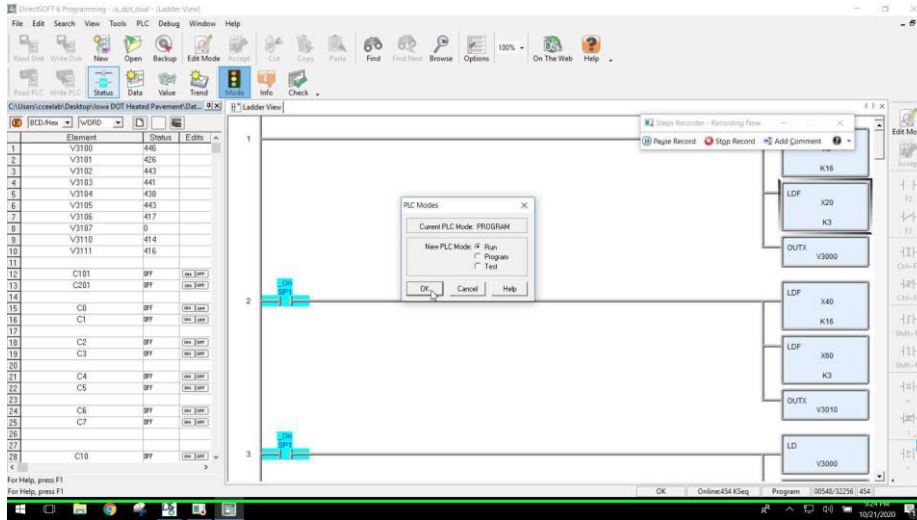

Figure C-5. Step 6 screenshot

Step 7: Left double click the ON button for the C101. This initiates automatic operation of the system. In order to end the operation, click the on/off button.

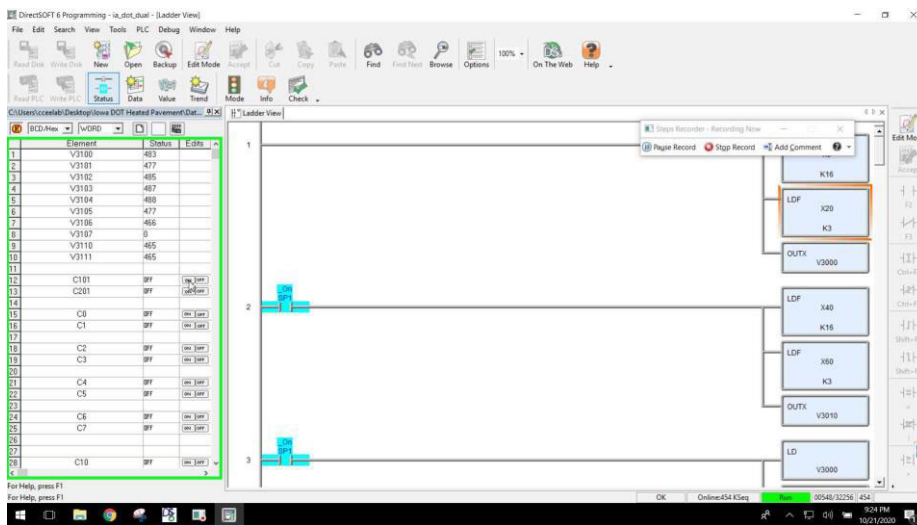

Figure C-6. Step 7 screenshot

**THE INSTITUTE FOR TRANSPORTATION IS THE FOCAL POINT FOR TRANSPORTATION
AT IOWA STATE UNIVERSITY.**

InTrans centers and programs perform transportation research and provide technology transfer services for government agencies and private companies;

InTrans contributes to Iowa State University and the College of Engineering's educational programs for transportation students and provides K–12 outreach; and

InTrans conducts local, regional, and national transportation services and continuing education programs.



**IOWA STATE
UNIVERSITY**

Visit InTrans.iastate.edu for color pdfs of this and other research reports.

New definition in Article 100

Conductive Pavement Heating System. A system in which heat is generated by passing current between electrodes embedded within the pavement material and through the pavement material. The pavement material may be primarily of concrete, or asphalt, or the like, and is typically constructed as bridge structures, walks, steps, roads or parking areas.

Article 426 Fixed Outdoor Electric Deicing and Snow-Melting Equipment

Part I. General

426.1 Scope. This article covers fixed outdoor electric deicing and snow-melting equipment and the installation of these systems.

(A) Embedded. Embedded in driveways, walks, steps, roads, and other areas.

(B) Exposed. Exposed on drainage systems, bridge structures, roofs, roads, and other structures.

Informational Note: See ANSI/IEEE 515.1-2012, Standard for the Testing, Design, Installation and Maintenance of Electrical Resistance Trace Heating for Commercial Applications, for further information. See IEEE 844/CSA 293 series of standards for fixed outdoor electric deicing and snow-melting equipment.

(C) Combination. Combinations of embedded and exposed equipment in driveways, walks, steps, roads, bridge structures and similar locations.

426.3 Other Articles. Cord-and-plug-connected fixed outdoor electric deicing and snow-melting equipment shall additionally comply with Table 426.3.

Table 426.3 Other Articles

Equipment	Article
Appliances	422 (Parts I, II, III, IV, V)

426.4 Continuous Load. Fixed outdoor electric deicing and snow-melting equipment shall be considered a continuous load.

426.6 Listing. A conductive pavement heating system shall be listed and installed in accordance with the installation instructions and conductive pavement mixture specifications.

Part II. Installation

426.10 General. Equipment for outdoor electric deicing and snow melting shall be identified as suitable for the environment and installed in accordance with the manufacturer's instructions.

426.11 Use. Electric heating equipment shall be installed in such a manner as to be afforded protection from physical damage.

426.12 Thermal Protection. External surfaces of outdoor electric deicing and snow-melting equipment that operate at temperatures exceeding 60°C (140°F) shall be physically guarded, isolated, or thermally insulated to protect against contact by personnel in the area.

426.13 Identification. The presence of outdoor electric deicing and snow-melting equipment shall be evident by the posting of appropriate caution signs or markings where clearly visible.

Part III. Resistance Heating Elements

426.20 Embedded Deicing and Snow-Melting Equipment.

(A) Watt Density. Panels or units shall not exceed 1300 watts/m² (120 watts/ft²) of heated area.

(B) Spacing. The spacing between adjacent cable runs is dependent upon the rating of the cable and shall be not less than 25 mm (1 in.) on centers.

(C) Cover. Units, panels, or cables shall be installed as follows:

(1) On a substantial concrete, masonry, or asphalt base at least 50 mm (2 in.) thick and have at least 38 mm (1 1/2 in.) of concrete, masonry, or asphalt applied over the units, panels, or cables; or

(2) They shall be permitted to be installed over other identified bases and embedded within 90 mm (3 1/2 in.) of concrete, masonry, or asphalt but not less than 38 mm (1 1/2 in.) from the top surface; or

(3) Equipment that has been listed for other forms of installation shall be installed only in the manner for which it has been identified.

(D) Secured. Cables, units, and panels shall be secured in place by frames or spreaders or other approved means while the concrete, masonry, or asphalt finish is applied.

(E) Expansion and Contraction. Cables, units, and panels shall not be installed where they bridge expansion joints unless provision is made for expansion and contraction.

426.21 Exposed Deicing and Snow-Melting Equipment.

(A) Secured. Heating element assemblies shall be secured to the surface being heated by identified means.

(B) Overtemperature. Where the heating element is not in direct contact with the surface being heated, the design of the heater assembly shall be such that its temperature limitations shall not be exceeded.

(C) Expansion and Contraction. Heating elements and assemblies shall not be installed where they bridge expansion joints unless provision is made for expansion and contraction.

(D) Flexural Capability. Where installed on flexible structures, the heating elements and assemblies shall have a flexural capability that is compatible with the structure.

426.22 Installation of Nonheating Leads for Embedded Equipment.

(A) Grounding Sheath or Braid. Except as permitted under 426.22(B), nonheating leads installed in concrete, masonry, or asphalt shall be provided with a grounding sheath or braid in accordance with 426.27 or shall be enclosed in rigid metal conduit, electrical metallic tubing, intermediate metal conduit, or other metal raceways.

(B) Splice Connections. The splice connection between the nonheating lead and heating element, within concrete, masonry, or asphalt, shall be located no less than 25 mm (1 in.) and no more than 150 mm (6 in.) from the metal raceway. The length of the nonheating lead from the metal raceway to the splice assembly shall be permitted to be provided without a grounding sheath or braid. Grounding continuity shall be maintained.

(C) Bushings. Insulating bushings shall be used in the concrete, masonry, or asphalt where the leads enter a metal raceway.

(D) Expansion and Contraction. Leads shall be protected in expansion joints in accordance with 300.4(H) or installed in accordance with the manufacturer's instructions.

(E) Emerging from Grade. Exposed nonheating leads shall be protected by raceways or other identified means.

(F) Leads in Junction Boxes. Not less than 150 mm (6 in.) of free nonheating lead shall be within the junction box.

426.23 Installation of Nonheating Leads for Exposed Equipment.

(A) Nonheating Leads. Power supply nonheating leads (cold leads) for resistance elements shall be identified for the temperature encountered. Not less than 150 mm (6 in.) of nonheating leads shall be provided within the junction box. Preassembled factory-supplied and field-assembled nonheating leads on approved heaters shall be permitted to be shortened if the markings specified in 426.25 are retained.

(B) Protection. Nonheating power supply leads shall be enclosed in a rigid conduit, intermediate metal conduit, electrical metallic tubing, or other approved means.

426.24 Electrical Connection.

(A) Heating Element Connections. Electrical connections, other than factory connections of heating elements to nonheating elements embedded in concrete, masonry, or asphalt or on exposed surfaces, shall be made with insulated connectors identified for the use.

(B) Circuit Connections. Splices and terminations at the end of the nonheating leads, other than the heating element end, shall be installed in a box or fitting in accordance with 110.14 and 300.15.

426.25 Marking. Each factory-assembled heating unit shall be legibly marked within 75 mm (3 in.) of each end of the nonheating leads with the permanent identification symbol, catalog number, and ratings in volts and watts or in volts and amperes.

426.26 Corrosion Protection. Ferrous and nonferrous metal raceways, cable armor, cable sheaths, boxes, fittings, supports, and support hardware shall be permitted to be installed in concrete or in direct contact with the earth, or in areas subject to severe corrosive influences, where made of material suitable for the condition, or where provided with corrosion protection identified as suitable for the condition.

426.27 Grounding Braid or Sheath. Grounding means, such as copper braid, metal sheath, or other approved means, shall be provided as part of the heated section of the cable, panel, or unit.

426.28 Ground-Fault Protection. Ground-fault protection shall be provided for fixed outdoor electric deicing and snow-melting equipment. The trip level of ground-fault protection shall be as specified by the manufacturer.

Part IV. Impedance Heating

426.30 Personnel Protection. Exposed elements of impedance heating systems shall be physically guarded, isolated, or thermally insulated with a weatherproof jacket to protect against contact by personnel in the area.

426.31 Isolation Transformer. An isolation transformer with a grounded shield between the primary and secondary windings shall be used to isolate the distribution system from the heating system.

426.32 Voltage Limitations. The secondary winding of the isolation transformer connected to the impedance heating elements shall not have an output voltage greater than 30 volts ac.

426.33 Induced Currents. All current-carrying components shall be installed in accordance with 300.20.

Part V. Skin-Effect Heating

426.40 Conductor Ampacity. The current through the electrically insulated conductor inside the ferromagnetic envelope shall be permitted to exceed the ampacity values shown in Table 310.16, provided it is identified as suitable for this use.

426.41 Pull Boxes. Where pull boxes are used, they shall be accessible without excavation by location in suitable vaults or above grade. Outdoor pull boxes shall be of watertight construction.

426.42 Single Conductor in Enclosure. The provisions of 300.20 shall not apply to the installation of a single conductor in a ferromagnetic envelope (metal enclosure).

426.43 Corrosion Protection. Ferromagnetic envelopes, ferrous or nonferrous metal raceways, boxes, fittings, supports, and support hardware shall be permitted to be installed in concrete or in direct contact with the earth, or in areas subjected to severe corrosive influences, where made of material suitable for the condition, or where provided with corrosion protection identified as suitable for the condition. Corrosion protection shall maintain the original wall thickness of the ferromagnetic envelope.

426.44 Equipment Grounding Conductor. The ferromagnetic envelope shall be connected to an equipment grounding conductor at both ends; and, in addition, it shall be permitted to be connected to an equipment grounding conductor at intermediate points as required by its design.

Section 250.30 shall not apply to the installation of skin-effect heating systems.

Part VI Conductive Pavement Heating Systems

426.60 General. Except as modified in this Part, conductive pavement heating systems shall comply with Parts I, II and VII of Article 426 and the following additional requirements.

426.62 Engineered Design.

The engineering design shall comply with all the following.

(A) Site Specific Design. Conductive pavement heating systems shall be designed and specified for specific installation site applications within the limits of the listing and manufacturer's installation instructions.

(B) Professional Engineer Required. The engineer shall be a licensed professional electrical engineer retained by the system owner or installer.

(C) Documentation. Documentation of the engineered design of the conductive pavement heating system shall be stamped and provided to the Authority Having Jurisdiction. The installation instructions, mixture specifications, and required conductivity test reports shall be provided to the Authority Having Jurisdiction.

(D) Additional Design Information. Additional stamped independent engineering reports detailing compliance of the design with applicable electrical standards and industry practice shall be provided upon request of the Authority Having Jurisdiction.

(E) Conformance Documentation. Conformance documentation shall include details of conformance of the design with the applicable parts of Article 426, or other articles of this Code.

426.64 Installation Engineering Supervision. Conductive pavement heating systems shall be installed under design engineering supervision and in accordance with the manufacturer's instructions. All documentation shall be provided to the Authority Having Jurisdiction.

426.66 Conductive Pavement Heating System

(A) Cover. Embedded electrodes shall be installed in accordance with the product listing and the following:

(1) On a substantial concrete, masonry, or asphalt base at least 100 mm (4 in.) thick and having at least 50 mm (2 in.) of conductive pavement applied under the electrodes and over the top of the electrodes; or

(2) The electrodes shall be permitted to be installed over other identified structural bases and embedded within 150 mm (6 in.) of conductive pavement with not less than 50 mm (2 in.) under the electrodes and over the top of the electrodes; or

(3) Equipment that has been listed for other forms of installation shall be installed only in the manner for which it has been identified.

(B) Secured. Electrodes and supply conductors shall be secured in place by frames or spreaders or other approved means while the conductive pavement is installed.

(C) Expansion and Contraction. Electrodes and supply conductors shall not be installed where they bridge expansion joints unless provision is made for expansion, contraction or other movement.

(D) Overtemperature. The conductive pavement system shall be monitored for surface temperatures and have overtemperature protection installed set not greater than 15°C (60°F). An overtemperature condition shall cause the power to the electrodes to be deenergized.

(E) Flexural Capability. Where installed on flexible structures, the electrodes and associated equipment shall have a flexural capability that is compatible with the movement of the structure.

426.68- Installation of Nonheating Leads.

(A) Nonheating Leads. Power supply nonheating leads (cold leads) for connection to the electrodes shall be identified for the temperature encountered. Not less than 150 mm (6 in.) of nonheating leads shall be provided within junction boxes.

(B) Protection. Nonheating leads shall be enclosed in a rigid nonmetallic conduit or other approved means.

426.70 Electrical Connection.

(A) Electrode Connections. Electrical connections, other than factory connections of electrodes to nonheating leads, shall be made with insulated connectors identified for the use.

(B) Circuit Connections. Splices and terminations at the end of the nonheating leads, other than the electrode end, shall be installed in a box or fitting in accordance with 110.14 and 300.15.

426.72 Corrosion Protection. Ferrous and nonferrous metal raceways, boxes, fittings, supports, and support hardware shall be permitted to be installed in pavement or in direct contact with the earth, or in areas subject to severe corrosive influences, where made of material suitable for the condition, or where provided with corrosion protection identified as suitable for the condition.

426.74 Ground-Fault Protection. Ground-fault protection of equipment shall be provided for the electrodes used in conductive pavement heating systems. The trip

level of ground-fault protection shall be as specified by the conductive pavement heating system manufacturer and listing.

426.76 Conductive Pavement Materials. The conductive pavement materials shall be mixed in accordance with the specifications from the installation instructions. The maximum and minimum limits for resistance or conductivity shall be provided in the installation instructions and in accordance with the listing.

426.78 Conductivity Testing. The conductive pavement material mixture shall be tested for resistance or conductivity and the test report provided to the Authority Having Jurisdiction. Final approval for the installation shall not be granted until all material test reports have been provided and reviewed.

426.80 Equipment Mounting. Structures or equipment mounted onto the conductive pavement surface shall be electrically bonded together and connected to the equipment grounding system.

426.82 Grounding and Bonding.

An 8 AWG bare copper ground ring shall be installed and connected to the equipment grounding conductors. The ground ring and associated connections shall comply with the following:

- (1) The conductors follow the contour of the perimeter surface.
- (2) Only listed splicing devices suitable for direct burial or concrete encasement, or exothermic welding are used.
- (3) The conductor(s) is 150 mm to 300 mm (6 in. to 12 in.) outside the perimeter of the conductive pavement heating system.
- (4) The conductor(s) is under the perimeter surface 100 mm to 150 mm (4 in. to 6 in.) below finished grade.

Part VI VII. Control and Protection

426.590 Disconnecting Means.

(A) Disconnection. All fixed outdoor deicing and snow-melting equipment shall be provided with a means for simultaneous disconnection from all ungrounded conductors. Where readily accessible to the user of the equipment, the branch-circuit switch or circuit breaker shall be permitted to serve as the disconnecting means. The disconnecting means shall be of the indicating type and be capable of being locked in the open (off) position.

(B) Cord-and-Plug-Connected Equipment. The factory-installed attachment plug of cord-and-plug-connected equipment rated 20 amperes or less and 150 volts or less to ground shall be permitted to be the disconnecting means.

426.5492 Controllers.

(A) Temperature Controller with “Off” Position. Temperature-controlled switching devices that indicate an “off” position and that interrupt line current shall open all ungrounded conductors when the control device is in the “off” position. These devices shall not be permitted to serve as the disconnecting means unless they are capable of being locked in the open position in compliance with 110.25.

(B) Temperature Controller Without “Off” Position. Temperature controlled switching devices that do not have an “off” position shall not be required to open all ungrounded conductors and shall not be permitted to serve as the disconnecting means.

(C) Remote Temperature Controller. Remote controlled temperature-actuated devices shall not be required to meet the requirements of 426.5492(A). These devices shall not be permitted to serve as the disconnecting means.

(D) Combined Switching Devices. Switching devices consisting of combined temperature-actuated devices and manually controlled switches that serve both as the controller and the disconnecting means shall comply with all of the following conditions:

- (1) Open all ungrounded conductors when manually placed in the “off” position
- (2) Be so designed that the circuit cannot be energized automatically if the device has been manually placed in the “off” position
- (3) Be capable of being locked in the open position in compliance with 110.25

426.5494 Cord-and-Plug-Connected Deicing and Snow-Melting Equipment. Cord-and-plug-connected deicing and snow-melting equipment shall be listed.

Substantiation

Introduction

A conductive concrete heating system that has been developed by the Iowa State University Department of Civil, Construction and Environmental Engineering with several pilot installations. These installations have the pavement surface with electrodes embedded within the pavement and placed at a set distance but not in direct contact with each other. The pavement mixture has additives, such as carbon fiber, included to enhance and increase the conductivity.

Existing NEC Does Not Provide Coverage

The present NEC requirements do not address this new technology. Because this technology is very different than present systems covered by Article 426 a new Part VI is proposed along with other changes specific to the conductive pavement applications. Many of these requirements were taken from those existing in Article 426 and adapted to this new technology.

Background

Over the past decade several research projects have been undertaken to develop alternate methods for snow melting and deicing paved surfaces. This includes sidewalks, steps to public buildings, bridges, bus stops, roadways and similar locations. The primary driver behind seeking the alternatives is the environmental impact of using chemicals as well as the cost in labor and equipment to facilitate snow or ice removal. Even with all the efforts from government and private entities, there are numerous minor to very serious injuries every year from slips and falls on icy or snow-covered walkways.

These projects have ranged from University of Alaska, Anchorage to Iowa State University Department of Civil, Construction and Environmental Engineering among others. There is also interest in implementing this technology by the FAA, transportation departments in Michigan, Colorado, Missouri and others as well as the US Department of Transportation. A web search will identify a number of research papers and other literature promoting the concept of heated pavements using other than the traditional methods. Many pavement materials, concrete or asphalt for example, have some level of conductivity. Regular Portland Cement Concrete (PCC) is conductive and is recognized as such by the NEC, for example, its use in a concrete encased electrode, reference 250.52(A)(3) and as a grounded surface when considering working space in 110.26(A) and 110.34(A). For further information on the research from Iowa State University, see the final report from October 2021 by Iowa State University at this web site:

<https://intrans.iastate.edu/research/completed/self-heating-electrically-conductive-concrete-demonstration-project/>

System Operation

Controls are provided to sense the presence of snow or ice to activate the system and monitor proper operation. When the control system senses snow or icing of the pavement, the system applies a voltage between the electrodes, for example 120 volts AC, and current then flows through the resistance of the conductive pavement generating heat. The temperatures required are only high enough to melt any accumulated snow or ice and to keep ice from forming on the surface. This is approximately 40°F. The system only applies power to the electrodes when needed as determined by a snow switch and pavement temperature sensing units.

Proposed NEC Sections Technical Discussion

A new definition for Conductive Pavement Heating System has been added to Article 100 for this new technology. This has been recommended to be under the purview of CMP-17 and applicable to Article 426 only. This is to be considered under public input 3479.

The scope of Article 426 has been modified to accommodate this technology and provide coverage for this system that has a combination of embedded and exposed elements. Since this new technology is neither fully embedded nor fully exposed, a new item "(C)" has been added to incorporate systems that are a combination of embedded and exposed elements. The electrodes for this system are fully embedded into the pavement but since the pavement itself is part of the heating circuit, that is obviously exposed.

A new listing requirement, 426.6, has been added specific to this technology. The numbering and location are to comply with the NEC Style Manual. The Iowa Department of Transportation has engaged UL Solutions in developing the listing requirements, either as a modification to an existing standard or development of a new standard. That project is being conducted in parallel and coordinated with the proposed changes to the NEC as this Code cycle progresses.

No changes are proposed to Parts II through V as these parts are specific with different concepts and unrelated technologies. Due to the unique nature of this technology, it was determined a whole new part was needed, therefore the creation of the new Part VI and renumbering of the existing Part VI to Part VII. This is consistent with other parts in Article 426 that address a specific type of equipment or system.

New Part VI

The new part is recommended to become Part VI and the existing Part VI to be renumbered to Part VII with applicable renumbering of the three affected sections. The public input has made the applicable edits to the new Part VII and verified renumbering in cross references. Many of the requirements in this part were extracted from previous parts and modified to fit this new technology. The general sequence remained the same as in previous parts for consistency and usability.

A new general requirement is included to clarify what previous parts of Article 426 are to be included for installations of conductive pavement heating systems. In addition to the

listing requirements, the design and oversight of the installation of conductive pavement heating systems is required to be conducted by a registered professional engineer. This is similar to existing NEC requirements found in 371.14 and 691.6. Having the design professional for the custom design of each system with the standardized specification and listing by a recognized testing laboratory provides the Authority Having Jurisdiction with a solid body of information to assist in the approval of the installation. This aspect was strongly recommended by the AHJs that are part of the Iowa DOT team working on this project.

There are clear documentation requirements for the initial design through the final installation to be provided to the Authority Having Jurisdiction for review and approval. The manufacturer's instructions, that will be part of the listing, and the specifications for the pavement batch mixing are required for the AHJ to evaluate conformance of the installation. This is aided by the requirement that the design engineer oversee the installation and provide to the AHJ specific reports as part of the project. One of these reports would be the testing results for the resistance or conductivity of the conductive pavement materials. The testing specifics are in development but will likely include fresh "wet" testing as well as testing after a curing period.

The primary hazards are potential shock if there is sufficient voltage on the surface where someone can contact it and have current through the body. This is considered for when both contact points are on the conductive pavement and when one is on the pavement and the other is off the pavement on an adjacent surface. Part of the research completed by Iowa State University has determined this condition to be mitigated to a safe level and further evaluation will be part of the UL Solutions project.

The other hazard is from a surface becoming excessively hot. The level of heat required is only to melt snow or prevent icing, which is about 40°F per the research completed. The temperature limits set in the proposed requirements are 15°C or 60°F which are well below the 50°C or 122°F allowed in many UL standards for contact without burns.

Code sections have been included for physical location of electrodes within the pavement for coverage of the conductive pavement material over and under the electrodes. In addition, requirements from transportation construction standards are provided to ensure a solid base under the pavement to mitigate ground movement. An alternative is permitted where the listing allows a different base or supporting system. Expansion and contraction are also covered to ensure that this action does not cause failures of the electrodes or associated equipment. Structures such as bridges are going to have natural movement and flexing and this needs to be accounted for in the design and installation.

The power supply lead and all controls are to be installed in non-metallic conduit such as PVC or RTRC to ensure physical protection of the conductors as well as isolation of the conductive pavement, so the current is controlled on the proper paths.

All the electrical components are required to be resistant to corrosion for the environment at the intended installation site. The electrodes in the design are specified to be a corrosion resistant stainless-steel material. The other metal electrical raceways and exposed components can have typical corrosion resistant construction or have supplemental corrosion protection if needed by the environmental conditions.

As provided in 426.28 today, ground fault protection is installed on all the power circuits to the electrodes. The ground fault trip levels would be the same as 426.28 in the 20 to 50 mA range. The trip level for the listed system will be part of the listing evaluation and listing specification. As with the other snow melting and deicing systems, Class A GFCI has a trip level such that the system would not remain in operation.

Since the pavement itself is purposefully conductive and part of the circuit, grounding and bonding will need to accommodate this fact. A means for a ground ring in the surrounding area where the conductive pavement is installed, similar to the equipotential deck for swimming pools and spas, is provided in the requirements. The equipment grounding conductors would then attach to this ground ring conductor as there is no place to attach within the conductive pavement without affecting the proper operation and control of current flow. This ring installation will provide a return path for any leakage from the electrically conductive pavement.



Public Input No. 3741-NFPA 70-2023 [Section No. 426.3]

426.3– ~~XX~~ Other Articles.

Cord-and-plug-connected fixed outdoor electric deicing and snow-melting equipment shall additionally comply with Table 426.3.

Table 426.3 Other Articles

<u>Equipment</u>	<u>Article</u>
Appliances	422 (Parts I, II, III, IV, V)

Statement of Problem and Substantiation for Public Input

The requirement should be relocated for compliance with the NEC Style Manual Section 2.2.1.

Submitter Information Verification

Submitter Full Name: Derrick Atkins

Organization: Minneapolis Electrical JATC

Street Address:

City:

State:

Zip:

Submittal Date: Tue Sep 05 15:18:55 EDT 2023

Committee: NEC-P17

Committee Statement

Resolution: [FR-8912-NFPA 70-2024](#)

Statement: Rather than move the referenced section, this section was deleted because reference to Article 422 is not needed as it applies regardless per 90.3.



Public Input No. 987-NFPA 70-2023 [Section No. 426.3]

426.3 Other Articles.

Cord-and-plug-connected fixed outdoor electric deicing and snow-melting equipment shall additionally comply with ~~Table 426.3~~ :

~~Table 426.3 Other Articles~~

~~Equipment Article Appliances 422 (Parts I, II, III, IV, V)~~

the applicable appliance requirements found elsewhere in this code.

Statement of Problem and Substantiation for Public Input

Section 4.1.4 of the NEC(r) Style Manual prohibits references to entire articles other than Article 100 or where required for context. As such, it is suggested to refer the user to the appliance requirements found elsewhere. The index or the table of contents can easily lead the user to the article if needed. Pointing to all parts of an article is the same as pointing to the entire article and is prohibited accordingly.

Submitter Information Verification

Submitter Full Name: Richard Holub

Organization: The DuPont Company, Inc.

Street Address:

City:

State:

Zip:

Submittal Date: Thu Jun 08 12:17:00 EDT 2023

Committee: NEC-P17

Committee Statement

Resolution: [FR-8912-NFPA 70-2024](#)

Statement: Rather than move the referenced section, this section was deleted because reference to Article 422 is not needed as it applies regardless per 90.3.



Public Input No. 2533-NFPA 70-2023 [Section No. 426.51]

426.51 Controllers.

(A) Temperature Controller with "Off" Position.

Temperature-controlled switching devices that indicate an "off" position and that interrupt line current shall open all ungrounded conductors when the control device is in the "off" position. These devices shall not be permitted to serve as the disconnecting means unless they are ~~capable of being locked in the open position in compliance~~ lockable open in accordance with 110.25.

(B) Temperature Controller Without "Off" Position.

Temperature controlled switching devices that do not have an "off" position shall not be required to open all ungrounded conductors and shall not be permitted to serve as the disconnecting means.

(C) Remote Temperature Controller.

Remote controlled temperature-actuated devices shall not be required to meet the requirements of 426.51(A). These devices shall not be permitted to serve as the disconnecting means.

(D) Combined Switching Devices.

Switching devices consisting of combined temperature-actuated devices and manually controlled switches that serve both as the controller and the disconnecting means shall comply with all of the following conditions:

- (1) Open all ungrounded conductors when manually placed in the "off" position
- (2) Be so designed that the circuit cannot be energized automatically if the device has been manually placed in the "off" position
- (3) Be ~~capable of being locked in the open position in compliance~~ lockable open in accordance with 110.25

Statement of Problem and Substantiation for Public Input

This Public Input is being submitted on behalf of the NEC Correlating Committee Usability Task Group in order to provide correlation throughout the document when a disconnecting means is required to be lockable open elsewhere in the code. The NEC Style Manual Section 3.2.5 Consistent Application of Terms, 3.2.5.3 This Public Input is being submitted on behalf of the NEC Correlating Committee Usability Task Group in order to provide correlation throughout the document when a disconnecting means is required to be lockable open elsewhere in the code. The text is revised to comply with the NEC Style Manual. The NEC Style Manual Section 3.2.5 Consistent Application of Terms, 3.2.5.3 Lockable Open. Where a requirement specifies that a disconnecting means be capable of being locked in the open position, the phrase lockable open in accordance with 110.25 shall be used. The Usability Task Group members are: Derrick Atkins, David Hittinger, Richard Holub, Dean Hunter, Chad Kennedy and David Williams.

Submitter Information Verification

Submitter Full Name: David Williams

Organization: Delta Charter Township

Street Address:

City:

State:

Zip:

Submittal Date: Sat Aug 19 21:46:03 EDT 2023

Committee: NEC-P17

Committee Statement

Resolution: [FR-8914-NFPA 70-2024](#)

Statement: Editorial revisions were made to comply with section 3.2.5.3 of the NEC Style Manual.



Public Input No. 2204-NFPA 70-2023 [Section No. 427.1]

427.1 Scope.

This article covers electrically energized heating systems and the installation of these systems used with pipelines, vessels, and ~~vessels~~ other applications .

Informational Note: See- ~~IEEE 515-2017~~ , *Standard for the Testing, Design, Installation and Maintenance of Electrical Resistance Trace Heating for Industrial Applications*, for further information.

Also see applicable sections of the IEEE 844/CSA 293 series of standards for alternate technologies for fixed electric heating equipment for pipelines and vessels.

Statement of Problem and Substantiation for Public Input

Heat trace is often used for other applications such as freeze protection at commercial and industrial freezer doors. There is not a code article that applies to the safe installation and use of heat tape for that and other applications. The scope needs to be expanded so there is enforceable language where AHJs encounter these other applications for heat trace. These other systems often use the same materials as the pipe and vessel heat tracing.

Submitter Information Verification

Submitter Full Name: Don Ganiere

Organization: none

Street Address:

City:

State:

Zip:

Submittal Date: Mon Aug 14 14:34:38 EDT 2023

Committee: NEC-P17

Committee Statement

Resolution: [FR-8917-NFPA 70-2024](#)

Statement: The title and scope of the article were revised to reflect installations of trace heating aka "heat trace" beyond those used for just pipelines and vessels, for example, installations of heat trace for doors of commercial freezers and similar applications.



Public Input No. 3743-NFPA 70-2023 [Section No. 427.3]

427.3– ~~XX~~ Other Articles.

Cord-connected pipe heating assemblies shall additionally comply with Table 427.3.

Table 427.3 Other Articles

<u>Equipment</u>	<u>Article</u>
Appliances	422 (Parts I, II, III, IV, V)

Statement of Problem and Substantiation for Public Input

The requirement should be relocated for compliance with the NEC Style Manual Section 2.2.1.

Submitter Information Verification

Submitter Full Name: Derrick Atkins

Organization: Minneapolis Electrical JATC

Street Address:

City:

State:

Zip:

Submittal Date: Tue Sep 05 15:19:31 EDT 2023

Committee: NEC-P17

Committee Statement

Resolution: [FR-8921-NFPA 70-2024](#)

Statement: This section was deleted because reference to Article 422 is not needed as it applies regardless. Rather than move the referenced section, this section was deleted because reference to Article 422 is not needed as it applies regardless per 90.3.



Public Input No. 988-NFPA 70-2023 [Section No. 427.3]

427.3 Other Articles.

Cord-connected pipe heating assemblies shall additionally comply with ~~Table 427.3 -~~

~~Table 427.3 Other Articles~~

~~Equipment Article Appliances 422 (Parts I, II, III, IV, V)~~

the applicable appliance requirements found elsewhere in this code.

Statement of Problem and Substantiation for Public Input

Section 4.1.4 of the NEC(r) Style Manual prohibits references to entire articles other than Article 100 or where required for context. As such, it is suggested to refer the user to the appliance requirements found elsewhere. The index or the table of contents can easily lead the user to the article if needed. Pointing to all parts of an article is the same as pointing to the entire article and is prohibited accordingly.

Submitter Information Verification

Submitter Full Name: Richard Holub

Organization: The DuPont Company, Inc.

Street Address:

City:

State:

Zip:

Submittal Date: Thu Jun 08 12:21:48 EDT 2023

Committee: NEC-P17

Committee Statement

Resolution: [FR-8921-NFPA 70-2024](#)

Statement: This section was deleted because reference to Article 422 is not needed as it applies regardless. Rather than move the referenced section, this section was deleted because reference to Article 422 is not needed as it applies regardless per 90.3.



Public Input No. 2534-NFPA 70-2023 [Section No. 427.55(A)]

(A) Switch or Circuit Breaker.

Means shall be provided to simultaneously disconnect all fixed electric pipeline or vessel heating equipment from all ungrounded conductors. The branch-circuit switch or circuit breaker, where readily accessible to the user of the equipment, shall be permitted to serve as the disconnecting means. The disconnecting means shall be of the indicating type and shall be capable of being locked in the open (off) position. The disconnecting means shall be ~~installed~~ lockable open in accordance with 110.25.

Statement of Problem and Substantiation for Public Input

This Public Input is being submitted on behalf of the NEC Correlating Committee Usability Task Group in order to provide correlation throughout the document when a disconnecting means is required to be lockable open elsewhere in the code. The text is revised to comply with the NEC Style Manual. The NEC Style Manual Section 3.2.5 Consistent Application of Terms, 3.2.5.3 Lockable Open. Where a requirement specifies that a disconnecting means be capable of being locked in the open position, the phrase lockable open in accordance with 110.25 shall be used.

The Usability Task Group members are: Derrick Atkins, David Hittinger, Richard Holub, Dean Hunter, Chad Kennedy and David Williams.

Submitter Information Verification

Submitter Full Name: David Williams

Organization: Delta Charter Township

Street Address:

City:

State:

Zip:

Submittal Date: Sat Aug 19 21:48:21 EDT 2023

Committee: NEC-P17

Committee Statement

Resolution: [FR-8923-NFPA 70-2024](#)

Statement: Editorial revisions were made to comply with section 3.2.5 of the NEC Style Manual.



Public Input No. 3620-NFPA 70-2023 [New Article after 680]

Relocate Article 680 to a stand-alone Chapter XX for Bodies of Water.

Statement of Problem and Substantiation for Public Input

Consider creating a separate Chapter within the NEC to cover the requirements for "Bodies of Water" (Refer to National Electrical Code® Correlating Committee White Paper: "Keeping the NEC® Relevant – Is Now the Time to Modernize?").

Chapter XX Installations Associated with Bodies of Water

- XX10 Swimming Pools, Fountains, and Similar Installations (Article 680)
- XX12 Natural and Artificially Made Bodies of Water (Article 682)
- XX14 Marinas, Boatyards, Floating Buildings, and Commercial and Noncommercial Docking Facilities (Article 555)

Enforcement of the NEC is conducted by many disciplines that can include electrical inspectors, consulting engineers, building officials and fire officials. By grouping "bodies of water" in one Chapter, it would encourage a more robust layout that will enhance the stability and usability for the next several decades and beyond.

Related Public Inputs for This Document

<u>Related Input</u>	<u>Relationship</u>
<u>Public Input No. 3778-NFPA 70-2023 [New Article after 555]</u>	Proposed relocation of Article 555
<u>Public Input No. 3774-NFPA 70-2023 [New Article after 682]</u>	Proposed relocation of Article 682
<u>Public Input No. 3774-NFPA 70-2023 [New Article after 682]</u>	
<u>Public Input No. 3778-NFPA 70-2023 [New Article after 555]</u>	

Submitter Information Verification

Submitter Full Name: Dean Hunter
Organization: Minnesota Department of Labor
Street Address:
City:
State:
Zip:
Submittal Date: Tue Sep 05 09:34:47 EDT 2023
Committee: NEC-P17

Committee Statement

Resolution: CMP17 does not support the creation of a new NEC Chapter currently. The NEC is likely to receive wholesale changes to the 2029 edition, including reorganization. Additionally, it

is important to retain the knowledge and long-standing history of requirements in Article 680, which current CMP17 members have.



Public Input No. 2807-NFPA 70-2023 [New Section after 680.1]

680.2 Listing Requirements.

All electrical equipment covered by this article shall be listed

Statement of Problem and Substantiation for Public Input

This Public Input is being submitted on behalf of the NEC Correlating Committee Usability Task Group in order to provide correlation throughout the document when general listing requirements are covered within an article. The NEC Style Manual Section 2.2.1 Parallel Numbering Required, states that technical committees shall use the following section numbers for the same purposes within articles. The listing requirements are to be located in the .2 section.

The Usability Task Group members are: Derrick Atkins, David Hittinger, Richard Holub, Dean Hunter, Chad Kennedy and David Williams.

Related Public Inputs for This Document

<u>Related Input</u>	<u>Relationship</u>
<u>Public Input No. 2808-NFPA 70-2023 [Section No. 680.6]</u>	Delete and relocate to the .2 section.
<u>Public Input No. 2808-NFPA 70-2023 [Section No. 680.6]</u>	

Submitter Information Verification

Submitter Full Name: Dean Hunter
Organization: Minnesota Department of Labor
Street Address:
City:
State:
Zip:
Submittal Date: Fri Aug 25 13:28:27 EDT 2023
Committee: NEC-P17

Committee Statement

Resolution: FR-9044-NFPA 70-2024

Statement: To comply with the NEC style manual section 2.2.1, the requirement for Listing is being moved from 680.6 to 680.2.



Public Input No. 4500-NFPA 70-2023 [Section No. 680.5(B)]

(B) 150 Volts or Less to Ground.

Where required in this article, ground-fault protection of receptacles and outlets on branch circuits rated 150 volts or less to ground and 60 amperes or ~~less~~ less single-phase, ~~single-~~ or 100 amperes or less 3-phase, shall be provided with a Class A GFCI.

Exception: Receptacles and outlets that are part of listed equipment with ratings not exceeding the low-voltage contact limit that are supplied by listed transformers or power supplies that comply with 680.23(A)(2) shall not be required to be provided with ground-fault protection.

Informational Note: The high leg of a 120/240-volt 4-wire delta-connected system, and the two ungrounded phases of a corner-grounded delta system have a voltage to ground greater than 150 volts, exceeding the limit for a Class A GFCI.

Statement of Problem and Substantiation for Public Input

Equipment is now being used that is above the 60 A value currently stated in the code. GFCI devices are commercially available at the 100 A rating, and moving the three-phase limit to 100 A correlates to other parts of the code (210.8(B)).

Related Public Inputs for This Document

<u>Related Input</u>	<u>Relationship</u>
Public Input No. 4511-NFPA 70-2023 [Section No. 680.22(A)(4)]	
Public Input No. 4518-NFPA 70-2023 [Section No. 680.32]	
Public Input No. 4520-NFPA 70-2023 [Section No. 680.43(A)(2)]	
Public Input No. 4527-NFPA 70-2023 [Section No. 680.58]	

Submitter Information Verification

Submitter Full Name: Mark Pollock
Organization: Littelfuse
Street Address:
City:
State:
Zip:
Submittal Date: Thu Sep 07 16:35:53 EDT 2023
Committee: NEC-P17

Committee Statement

Resolution: [FR-9045-NFPA 70-2024](#)

Statement: Section 680.5(B) currently stipulates a 60-ampere threshold for equipment requiring ground-fault circuit interrupter (GFCI) protection. Commercially available three-phase GFCI devices now offer ratings up to 100 amperes. This revision reflects the availability of higher-rated GFCI devices and harmonizes the code with existing provisions, such as

Section 210.8(B). Additionally, Section 680.5(B) was separated into a list (1) and (2) for improved usability.



Public Input No. 2808-NFPA 70-2023 [Section No. 680.6]

~~680.6~~ Listing Requirements:

~~All electrical equipment covered by this article shall be listed.~~

Statement of Problem and Substantiation for Public Input

This Public Input is being submitted on behalf of the NEC Correlating Committee Usability Task Group in order to provide correlation throughout the document when general listing requirements are covered within an article. The NEC Style Manual Section 2.2.1 Parallel Numbering Required, states that technical committees shall use the following section numbers for the same purposes within articles. The listing requirements are to be located in the .2 section.

The Usability Task Group members are: Derrick Atkins, David Hittinger, Richard Holub, Dean Hunter, Chad Kennedy and David Williams.

Related Public Inputs for This Document

<u>Related Input</u>	<u>Relationship</u>
<u>Public Input No. 2807-NFPA 70-2023 [New Section after 680.1]</u>	Delete and relocate to the .2 section
<u>Public Input No. 2807-NFPA 70-2023 [New Section after 680.1]</u>	

Submitter Information Verification

Submitter Full Name: Dean Hunter
Organization: Minnesota Department of Labor
Street Address:
City:
State:
Zip:
Submittal Date: Fri Aug 25 13:29:26 EDT 2023
Committee: NEC-P17

Committee Statement

Resolution: FR-9044-NFPA 70-2024

Statement: To comply with the NEC style manual section 2.2.1, the requirement for Listing is being moved from 680.6 to 680.2.



Public Input No. 1944-NFPA 70-2023 [Section No. 680.8]

680.8 Cord-and-Plug-Connected Equipment.

Fixed or stationary equipment, other than underwater luminaires, for a permanently installed pool shall be permitted to be connected with a flexible cord and plug to facilitate the removal or disconnection for maintenance or repair.

(A) Length.

For other than storable pools, the flexible cord shall not exceed 900 mm (3 ft) in length.

(B) Equipment Grounding.

~~The flexible cord shall have a copper equipment grounding conductor sized in accordance with 250.122 but not smaller than 12 AWG. The cord shall terminate in a grounding-type attachment plug.~~

~~(C) Construction.~~

~~The equipment grounding conductors shall be connected to a fixed metal part of the assembly. The removable part shall be mounted on or bonded to the fixed metal part.~~

Cord-and-plug connected equipment shall comply with 680.7(B).

Statement of Problem and Substantiation for Public Input

This PI proposes to delete redundant language. Section 680.7(B) has existing grounding and bonding requirements for cord and plug connections. Sections 680.8(B) and (C) do not need to repeat these requirements. A reference to 680.7(B) is sufficient as a reminder.

Submitter Information Verification

Submitter Full Name: Vincent Della Croce

Organization:

Street Address:

City:

State:

Zip:

Submittal Date: Tue Aug 08 11:37:01 EDT 2023

Committee: NEC-P17

Committee Statement

Resolution: FR-9049-NFPA 70-2024

Statement: Existing section 680.7(B) has grounding and bonding requirements for cord and plug connections. Redundant language in existing section 680.8(B) is deleted. Title for (A) was clarified to better reflect the requirements in this item. Section 680.8 first level subdivision (C) was clarified, and the title revised, and renumbered as (B).

The words “maintenance or repair” were changed to “servicing” for clarification, as “servicing” is a defined term and often encompasses maintenance and repair activities.



Public Input No. 2267-NFPA 70-2023 [Section No. 680.8(B)]

(B) Equipment Grounding Conductor .

The flexible cord shall have a copper equipment grounding conductor sized in accordance with 250.122 but not smaller than 12 AWG. The cord shall terminate in a grounding-type attachment plug.

Statement of Problem and Substantiation for Public Input

Changing the title would make the text technically correct. This requirement is about having an equipment grounding conductor of the wire type inside cords, not about grounding.

Submitter Information Verification

Submitter Full Name: Mike Holt

Organization: Mike Holt Enterprises Inc

Street Address:

City:

State:

Zip:

Submittal Date: Tue Aug 15 14:29:38 EDT 2023

Committee: NEC-P17

Committee Statement

Resolution: [FR-9049-NFPA 70-2024](#)

Statement: Existing section 680.7(B) has grounding and bonding requirements for cord and plug connections. Redundant language in existing section 680.8(B) is deleted. Title for (A) was clarified to better reflect the requirements in this item. Section 680.8 first level subdivision (C) was clarified, and the title revised, and renumbered as (B).

The words “maintenance or repair” were changed to “servicing” for clarification, as “servicing “ is a defined term and often encompasses maintenance and repair activities.



Public Input No. 1326-NFPA 70-2023 [Section No. 680.8 [Excluding any Sub-Sections]]

Fixed or stationary equipment, other than underwater luminaires, for a permanently installed pool shall be permitted to be connected with a flexible cord and plug to facilitate the removal or disconnection for maintenance or repair servicing.

Statement of Problem and Substantiation for Public Input

Servicing is a defined term and includes repairs. Using a defined term adds more clarity and helps avoid confusion between activities that are deemed as servicing and those that are deemed as reconditioning.

Submitter Information Verification

Submitter Full Name: Thomas Domitrovich

Organization: Eaton Corporation

Street Address:

City:

State:

Zip:

Submittal Date: Sat Jul 08 11:44:04 EDT 2023

Committee: NEC-P17

Committee Statement

Resolution: FR-9049-NFPA 70-2024

Statement: Existing section 680.7(B) has grounding and bonding requirements for cord and plug connections. Redundant language in existing section 680.8(B) is deleted. Title for (A) was clarified to better reflect the requirements in this item. Section 680.8 first level subdivision (C) was clarified, and the title revised, and renumbered as (B).

The words “maintenance or repair” were changed to “servicing” for clarification, as “servicing “ is a defined term and often encompasses maintenance and repair activities.



Public Input No. 1151-NFPA 70-2023 [Section No. 680.9(A)]

(A) Power.

Overhead conductors and open overhead wiring not in a raceway shall comply with the minimum clearances given in Table 680.9(A) and illustrated in Figure 680.9(A).

Table 680.9(A) Overhead Conductor Clearances

Clearance Parameters	Insulated Cables, 0–750 Volts to Ground, Supported on and Cabled Together with a Solidly Grounded Bare Messenger or Solidly Grounded Neutral Conductor		All Other Conductors Voltage to Ground			
			0 through 15 kV		Over 15 through 50 kV	
	m	ft	m	ft	m	ft
A. Clearance in any direction to the water level, edge of water surface, base of diving platform, or permanently anchored raft	22.5	-	7.5 25	-	8.0 27	
B. Clearance in any direction to the observation stand, tower, or diving platform	14.5	-	5.2 17	-	5.5 18	
C. Horizontal limit of clearance measured from inside wall of the pool	This limit shall extend to <u>The clearance requirements in this table are not applicable beyond 3 m (10 ft) horizontally from the outer edge of the structures listed in A and B of this table but not less than 3 m (10 ft)</u>					

Figure 680.9(A) Clearances from Pool Structures.

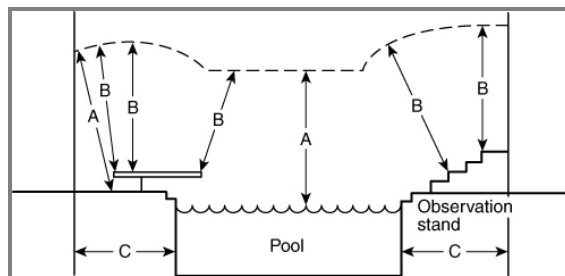

Statement of Problem and Substantiation for Public Input

The language of the code provided a false or misleading limit or violation by overhead conductors within the 10ft limit. This grey area used by FPL and contractors to limit pool size and location and errors by inspectors.

Submitter Information Verification

Submitter Full Name: Phil Petty

Organization: CITY OF WEST PALM BEACH

Street Address:

City:

State:

Zip:

Submittal Date: Tue Jun 20 13:24:25 EDT 2023

Committee: NEC-P17

Committee Statement

Resolution: The submitted input would expand the clearances of this table to 10 feet beyond any observation stand, diving board, or similar structure. Insufficient technical substantiation was provided to support this proposed change.



Public Input No. 646-NFPA 70-2023 [Section No. 680.10]

~~680.10 _ Electric Pool Water Heaters- Incorporating Resistive Heating Elements and Electrically Powered Swimming Pool Heat Pumps and Chillers .~~

~~(A) Electric Pool Water Heaters:~~

~~All electric pool water heaters incorporating resistive heating elements shall have the heating elements subdivided into loads not exceeding 48 amperes and protected at not over 60 amperes. The ampacity of the branch-circuit conductors and the rating or setting of overcurrent protective devices shall be 125 percent of the total nameplate-rated load or greater.~~

~~(B) Electrically Powered Swimming Pool Heat Pumps and Chillers:~~

~~Electrically powered swimming pool heat pumps and chillers using the circulating water system and providing heating, cooling, or both, shall be listed and rated for their intended use. The ampacity of the branch-circuit conductors and the rating or setting of overcurrent protective devices shall be sized to comply with the nameplate.~~

Statement of Problem and Substantiation for Public Input

Subdivision (B) is already covered by 680.6 and 110.3(B).

Submitter Information Verification

Submitter Full Name: Ryan Jackson
Organization: Self-employed
Street Address:
City:
State:
Zip:
Submittal Date: Mon Apr 17 12:30:27 EDT 2023
Committee: NEC-P17

Committee Statement

Resolution: For 2023 NEC, Section 680.10 title was revised, and heat pumps and chiller equipment were added to the article to address new technology that is being added to pool installations. This new technology is still in its early stages of implementation, and addressing this in this section provides guidance.



Public Input No. 4464-NFPA 70-2023 [Section No. 680.10(A)]

(A) Electric Pool Water Heaters.

(1) Resistance Elements. All electric pool water heaters incorporating resistive heating elements shall have the heating elements subdivided into loads not exceeding 48 amperes and protected at not over 60 amperes.

(2) Branch Circuit. The ampacity of the branch-circuit conductors and the ampere rating or setting of overcurrent protective devices shall be 125 percent of the total nameplate-rated load or greater.

Statement of Problem and Substantiation for Public Input

Breaking up 680.10(A) into a list item format to facilitate understanding for Code users. In accordance with NFPA Style Manual section 3.5.1.2 additional subdivisions shall be used where multiple requirements can be broken into independent requirements.

Submitter Information Verification

Submitter Full Name: Mike Holt

Organization: Mike Holt Enterprises Inc

Street Address:

City:

State:

Zip:

Submittal Date: Thu Sep 07 15:56:30 EDT 2023

Committee: NEC-P17

Committee Statement

Resolution: FR-9051-NFPA 70-2024

Statement: Section 680.10(A) is being revised into a list item format to facilitate understanding for Code users, and in accordance with NEC Style Manual section 3.5.1.2. Additionally, "ampere" was added for clarity.



Public Input No. 4465-NFPA 70-2023 [Section No. 680.10(B)]

(B) Electrically Powered Swimming Pool Heat Pumps and Chillers.

(1) Listing. Electrically powered swimming pool heat pumps and chillers using the circulating water system and providing heating, cooling, or both, shall be listed and rated for their intended use.

(2) Branch Circuit. The ampacity of the branch-circuit conductors and the ampere rating or setting of overcurrent protective devices shall be sized to comply with the nameplate.

Statement of Problem and Substantiation for Public Input

Breaking up 680.10(B) into a list item format to facilitate understanding for Code users. In accordance with NFPA Style Manual section 3.5.1.2 additional subdivisions shall be used where multiple requirements can be broken into independent requirements.

Submitter Information Verification

Submitter Full Name: Mike Holt
Organization: Mike Holt Enterprises Inc
Street Address:
City:
State:
Zip:
Submittal Date: Thu Sep 07 15:59:03 EDT 2023
Committee: NEC-P17

Committee Statement

Resolution: FR-9150-NFPA 70-2024

Statement: Section 680.10(B) is being revised into a list item format to facilitate understanding for Code users, and in accordance with NEC Style Manual section 3.5.1.2. Additionally, "ampere" was added for clarity and requirement for listing was removed as it is covered in 680.2.



Public Input No. 1459-NFPA 70-2023 [Section No. 680.12(B)]

(B) Receptacles.

At least one GFCI-protected 125-volt, 15- or 20-ampere receptacle ~~supplied from a general purpose branch circuit~~ shall be located within an equipment room. All ~~other~~ receptacles supplied by branch circuits rated 150 volts or less to ground within an equipment room ~~and any receptacles supplied by a branch circuit rated 150 volts or less to ground in a vault or pit shall~~ . vault, or pit shall be GFCI protected.

Statement of Problem and Substantiation for Public Input

A duplex receptacle is, by definition, always installed on a general-purpose branch circuit--even if that is the only thing on the circuit.

The other language marked for deletion is consolidated into the existing text for brevity.

Submitter Information Verification

Submitter Full Name: Ryan Jackson

Organization: Self-employed

Street Address:

City:

State:

Zip:

Submittal Date: Mon Jul 17 17:21:18 EDT 2023

Committee: NEC-P17

Committee Statement

Resolution: [FR-9054-NFPA 70-2024](#)

Statement: Commercially available three-phase GFCI devices now offer ratings up to 100 amperes, and single phase GFCI devices offer ratings up to 60 amperes. This revision also reflects the availability of higher-rated GFCI and SPGFCI devices up to 480V that can be applied to all receptacles within equipment room, vaults, or pits and harmonizes the code with existing provisions, such as Section 210.8(B).

The text was also separated into two subsections in accordance with NEC Style manual section 3.5.1.2.



Public Input No. 4467-NFPA 70-2023 [Section No. 680.12(B)]

(B) Receptacles.

(1) Required Receptacle. At least one GFCI-protected 125-volt, 15- or 20-ampere receptacle supplied from a general purpose branch circuit shall be located within an equipment room.

(2) GFCI Protection. All other receptacles supplied by branch circuits rated 150 volts or less to ground within an equipment room and any receptacles supplied by a branch circuit rated 150 volts or less to ground in a vault or pit shall be GFCI protected.

Statement of Problem and Substantiation for Public Input

Breaking up 680.12(B) into a list item format to facilitate understanding for Code users. In accordance with NFPA Style Manual section 3.5.1.2 additional subdivisions shall be used where multiple requirements can be broken into independent requirements.

Submitter Information Verification

Submitter Full Name: Mike Holt

Organization: Mike Holt Enterprises Inc

Street Address:

City:

State:

Zip:

Submittal Date: Thu Sep 07 16:03:03 EDT 2023

Committee: NEC-P17

Committee Statement

Resolution: FR-9054-NFPA 70-2024

Statement: Commercially available three-phase GFCI devices now offer ratings up to 100 amperes, and single phase GFCI devices offer ratings up to 60 amperes. This revision also reflects the availability of higher-rated GFCI and SPGFCI devices up to 480V that can be applied to all receptacles within equipment room, vaults, or pits and harmonizes the code with existing provisions, such as Section 210.8(B).

The text was also separated into two subsections in accordance with NEC Style manual section 3.5.1.2.



Public Input No. 2265-NFPA 70-2023 [Section No. 680.14(A)]

(A) Wiring Methods.

Wiring methods shall be suitable for use in corrosive environments. Rigid metal conduit, intermediate metal conduit, rigid polyvinyl chloride conduit, reinforced thermosetting resin conduit, ~~and liquidtight flexible nonmetallic conduit- shall~~, and liquidtight flexible metallic conduit marked "suitable for use in swimming pool corrosive environments" shall be considered suitable for use. Aluminum conduit and tubing shall not be permitted.

Statement of Problem and Substantiation for Public Input

LFMC is suitable for use in corrosive environments per UL 360. In addition, 680.21(A)(1) permits LFMC for flexible connections to pool motors and 350.10(3) permits LFMC for direct burial if listed for that purpose. This proposed revision will give Code users the option to use LFMC in swimming pool corrosive environments.

Submitter Information Verification

Submitter Full Name: Mike Holt
Organization: Mike Holt Enterprises Inc
Street Address:
City:
State:
Zip:
Submittal Date: Tue Aug 15 14:25:20 EDT 2023
Committee: NEC-P17

Committee Statement

Resolution: FR-9060-NFPA 70-2024
Statement: Liquidtight flexible metal conduit (LFMC) is suitable for use in corrosive environments per UL 360. In addition, 680.21(A)(1) permits LFMC for flexible connections to pool motors.



Public Input No. 645-NFPA 70-2023 [Section No. 680.14(B)]

(B) Other Equipment.

Other equipment shall be ~~suitable~~ identified for use in corrosive environments or be installed in ~~identified~~ corrosion-resistant enclosures. Equipment listed for pool and spa use shall be ~~considered suitable for use~~ permitted.

Statement of Problem and Substantiation for Public Input

The words "suitable" and "identified" mean the same thing (Art. 100 identified). This revision should be viewed as editorial.

Submitter Information Verification

Submitter Full Name: Ryan Jackson
Organization: Self-employed
Street Address:
City:
State:
Zip:
Submission Date: Mon Apr 17 12:26:41 EDT 2023
Committee: NEC-P17

Committee Statement

Resolution: [FR-9063-NFPA 70-2024](#)

Statement: The word "suitable" is replaced with the defined term "identified" for clarity and editorially changed to add "permitted" instead of "considered suitable for use."



Public Input No. 3719-NFPA 70-2023 [Section No. 680.20]

680.20 General.

Electrical installations at permanently installed pools, and semi-permanently installed pools shall comply with the provisions of Part I and Part II of this article.

Statement of Problem and Substantiation for Public Input

This revision is to ensure that the semi-permanent pool type is installed to ensure minimum electrical safety. This type of pool has been left in limbo since the current definitions of permanent and storable pools end up not covering this pool type. This pool type is meant to be left in place and winterized. It can be moved , but it was not designed for the ease of relocation.

Related Public Inputs for This Document

<u>Related Input</u>	<u>Relationship</u>
Public Input No. 3681-NFPA 70-2023 [New Definition after Definition: Pool, Permanently Installe...]	New definition and newly defined pool type added to section
Public Input No. 3695-NFPA 70-2023 [Definition: Pool, Permanently Installed Swimming, Wading, I...]	revised definition to help clarify pool type
Public Input No. 3700-NFPA 70-2023 [Definition: Pool, Storable; used for Swimming, Wading, or I...]	revised definition to help clarify pool type
Public Input No. 3710-NFPA 70-2023 [Part II.]	added pool type to part II title

Submitter Information Verification

Submitter Full Name: Ronald Dalrymple
Organization: City of Schertz Texas
Street Address:
City:
State:
Zip:
Submittal Date: Tue Sep 05 14:44:26 EDT 2023
Committee: NEC-P17

Committee Statement

Resolution: The submitter's objectives have been addressed by the revisions of the definitions of Permanently Installed Pools and Storable Pools. The type of pool suggested in the public input is now considered to be a storable pool unless a permanent deck is installed around all or part of the pool. Therefore, "semi-permanently installed pools" has not been added to the text in 680.20.



Public Input No. 1325-NFPA 70-2023 [Section No. 680.21(D)]

(D) Pool Pump Motor Replacement, Servicing and Reconditioning .

(1) Replacement

Where a pool pump motor in 680.21(C) is replaced- ~~or repaired~~ , the ~~replacement or repaired pump~~ replacement pump motor shall be provided with ground-fault protection complying with 680.5(B) or (C), as applicable.

(2) Serviced.

Where a pool pump motor in 680.21(C) is serviced, the serviced pump motor shall be provided with ground-fault protection complying with 680.5(B) or (C), as applicable.

(3) Reconditioned.

Where a pool pump motor in 680.21(C) is reconditioned, the reconditioned pump motor shall comply with 430.2 and marked in accordance with 110.21(A)(2) and be provided with ground-fault protection complying with 680.5(B) or (C), as applicable.

Statement of Problem and Substantiation for Public Input

The 2023 edition of the National Electrical Code now clearly establishes the difference between servicing and reconditioning. This public input offers a change to this section to recognize there are three distinct actions that can be taken: 1. Replacement, 2: Servicing and 3: Reconditioning. Servicing and Reconditioning are defined terms and replacement is obvious. The definition of Servicing also includes repairs. Using defined terms adds clarity and reduces confusion.

Submitter Information Verification

Submitter Full Name: Thomas Domitrovich
Organization: Eaton Corporation
Street Address:
City:
State:
Zip:
Submittal Date: Sat Jul 08 11:38:02 EDT 2023
Committee: NEC-P17

Committee Statement

Resolution: [FR-9153-NFPA 70-2024](#)

Statement: The term "reconditioned" was added to the requirement, and the Title expanded, both for clarity. The word "where" was changed to "if" to comply with the NEC Style Manual. The language regarding "repair" was not changed to "servicing," because "servicing" is a broader term than "repairing."



Public Input No. 1336-NFPA 70-2023 [Section No. 680.22(A)(4)]

~~(4) Ground-Fault Circuit-Interrupter (GFCI)- and Special Purpose Ground-Fault Circuit-Interrupter (SPGFCI) Protection .~~

~~All receptacles rated 125 volts through 250 volts, 60 amperes or less, located within 6.0 m (20 ft) of the inside walls of a pool shall have GFCI protection complying with 680.5(B)- or SPGFCI protection complying with 680 . 5(C), as applicable.~~

Statement of Problem and Substantiation for Public Input

This language is in conflict with the definition of a SPCGFCI. Article 100 defines the SPCGFCI as “A device intended for the detection of ground-fault currents, used in circuits with voltage to ground greater than 150 volts, that functions to de-energize a circuit or portion of a circuit within an established period of time when a ground-fault current exceeds the values established for Class C, D, or E devices. (CMP-2)”. This section speaks specifically to receptacles rated 125 volts through 250 volts.

Submitter Information Verification

Submitter Full Name: Thomas Domitrovich

Organization: Eaton Corporation

Street Address:

City:

State:

Zip:

Submittal Date: Sat Jul 08 12:17:30 EDT 2023

Committee: NEC-P17

Committee Statement

Resolution: The existing code language is not in conflict with the definition of a SPGFCI and the existing requirement is technically correct. Single- and three-phase receptacles rated 250-volts installed on 240-volt corner grounded delta systems or involving the high leg of a 120/240-volt 4-wire delta connected system have a voltage to ground greater than 150-volts and require SPGFCI (rather than GFCI) protection. These systems are discussed in the existing Informational Note to 680.5(B). Additional first revisions to this and other sections of Article 680 are being made to clarify that the range of voltages associated with SPGFCI includes 480V.



Public Input No. 2395-NFPA 70-2023 [Section No. 680.22(A)(4)]

(4) Ground-Fault Circuit-Interrupter (GFCI) and Special Purpose Ground-Fault Circuit-Interrupter (SPGFCI) Protection.

All receptacles rated 125 volts through 250 volts, 60 amperes or less, located within 6.0 m (20 ft) of the inside walls of a pool shall have GFCI protection complying with 680.5(B) or SPGFCI protection complying with 680.5(C), as applicable.

Exception: Shore power receptacles within 6.0 m (20 ft) of the inside walls of a pool shall comply with 555.35(B)(1) and not require GFCI protection.

Additional Proposed Changes

<u>File Name</u>	<u>Description</u>	<u>Approved</u>
680.22A3_01.png		

Statement of Problem and Substantiation for Public Input

This exception will provide guidance to the authority having jurisdiction on how to inspect installations where shore power receptacles are within 20 feet from pools. See uploaded photo.

Submitter Information Verification

Submitter Full Name: Mike Holt
Organization: Mike Holt Enterprises Inc
Street Address:
City:
State:
Zip:
Submittal Date: Wed Aug 16 16:32:18 EDT 2023
Committee: NEC-P17

Committee Statement

Resolution: Existing requirements in 680.22(A)(4) provide for protection against electric shock for receptacles that may be in the area of a pool, up to 20 ft away. Allowing an exemption for shore power or any other purpose, where the receptacles are not required to be protected by GFCI or SPGFCI, significantly increases the electric shock risk in the pool area.



Public Input No. 2439-NFPA 70-2023 [Section No. 680.22(A)(4)]

(4) Ground-Fault Circuit-Interrupter (GFCI) and Special Purpose Ground-Fault Circuit-Interrupter (SPGFCI) Protection.

All receptacles ~~rated 125 volts through 250 volts~~, 60 amperes or less, located within 6.0 m (20 ft) of the inside walls of a pool shall have GFCI protection complying with 680.5(B) or SPGFCI protection complying with 680.5(C), as applicable.

Statement of Problem and Substantiation for Public Input

Removing 'rated 125 volt through 250 volt' so this requirement would apply to 480V receptacles located within 20 feet of pool water. This enhances electrical safety in these areas where the shock hazard is increased.

Submitter Information Verification

Submitter Full Name: Mike Holt

Organization: Mike Holt Enterprises Inc

Street Address:

City:

State:

Zip:

Submittal Date: Thu Aug 17 11:53:34 EDT 2023

Committee: NEC-P17

Committee Statement

Resolution: [FR-9065-NFPA 70-2024](#)

Statement: Sections 680.22(A)(4) currently stipulates a 60-ampere threshold for equipment requiring ground-fault circuit interrupter (GFCI) protection. Commercially available three-phase GFCI devices now offer ratings up to 100 amperes. This revision reflects the availability of higher-rated GFCI devices and harmonizes the code with existing provisions, such as 210.8(B). Additionally, 680.22(A)(4) was separated into a list (A) and (B) for improved usability.



Public Input No. 4511-NFPA 70-2023 [Section No. 680.22(A)(4)]

(4) Ground-Fault Circuit-Interrupter (GFCI) and Special Purpose Ground-Fault Circuit-Interrupter (SPGFCI) Protection.

All receptacles rated 125 volts through 250 volts, 60 amperes or less single-phase, or 100 amperes or less three-phase, located within 6.0 m (20 ft) of the inside walls of a pool shall have GFCI protection complying with 680.5(B) or SPGFCI protection complying with 680.5(C), as applicable.

Statement of Problem and Substantiation for Public Input

Equipment is now being used that is above the 60 A value currently stated in the code. GFCI devices are commercially available at the 100 A rating, and moving the three-phase limit to 100 A correlates to other parts of the code such as 210.8(B).

Related Public Inputs for This Document

<u>Related Input</u>	<u>Relationship</u>
<u>Public Input No. 4500-NFPA 70-2023 [Section No. 680.5(B)]</u>	

Submitter Information Verification

Submitter Full Name: Mark Pollock
Organization: Littelfuse
Street Address:
City:
State:
Zip:
Submittal Date: Thu Sep 07 16:42:59 EDT 2023
Committee: NEC-P17

Committee Statement

Resolution: FR-9065-NFPA 70-2024

Statement: Sections 680.22(A)(4) currently stipulates a 60-ampere threshold for equipment requiring ground-fault circuit interrupter (GFCI) protection. Commercially available three-phase GFCI devices now offer ratings up to 100 amperes. This revision reflects the availability of higher-rated GFCI devices and harmonizes the code with existing provisions, such as 210.8(B). Additionally, 680.22(A)(4) was separated into a list (A) and (B) for improved usability.



Public Input No. 2241-NFPA 70-2023 [Section No. 680.22(A)(5)]

(5) Measurements.

In determining the dimensions in this section addressing receptacle spacings, the distance to be measured shall be the shortest path the ~~power-~~ supply cord ~~of an appliance-~~ connected to the receptacle would follow without piercing a floor, wall, ceiling, ~~doorway with hinged- or sliding door, window opening, or-~~ other effective permanent barrier.

Statement of Problem and Substantiation for Public Input

A power-supply cord is a defined term in Article 100. This proposed change will make the language technically correct based on the Article 100 definition of "power-supply cord." Deleting "doorway with hinged sliding door, window opening" to match the requirement in 210.8 on how to measure, these requirements should be consistent.

Submitter Information Verification

Submitter Full Name: Mike Holt
Organization: Mike Holt Enterprises Inc
Street Address:
City:
State:
Zip:
Submittal Date: Tue Aug 15 13:13:07 EDT 2023
Committee: NEC-P17

Committee Statement

Resolution: [FR-9067-NFPA 70-2024](#)

Statement: The word "Power-" is added to "supply cord", and "of an appliance" is deleted, to correlate with the existing defined term "power-supply cord" in Article 100.

The existing requirements regarding doorways and window openings are unique to pool/spa applications, and are not being deleted. The proposed revision might, for example, encourage receptacles just inside of a door or window to be used as the required receptacle in 680.22(A) list item 1.



Public Input No. 2394-NFPA 70-2023 [Section No. 680.22(B)(1)]

(1) New Outdoor Installation Clearances.

In outdoor pool areas, luminaires, lighting outlets, festoon lighting, and ceiling-suspended (paddle) fans installed above the pool or the area extending 1.5 m (5 ft) horizontally from the inside walls of the pool shall be installed at a height not less than 3.7 m (12 ft) above the maximum water level of the pool.

Statement of Problem and Substantiation for Public Input

Festoon lighting is installed above pools very frequently. Adding festoon lighting to this requirement will make it clear that it is not allowed per the NEC. This proposed revision enhances electrical safety from shock hazards in the swimming pool area.

Submitter Information Verification

Submitter Full Name: Mike Holt
Organization: Mike Holt Enterprises Inc
Street Address:
City:
State:
Zip:
Submission Date: Wed Aug 16 16:31:15 EDT 2023
Committee: NEC-P17

Committee Statement

Resolution: [FR-9071-NFPA 70-2024](#)

Statement: Festoon lighting is installed above pools very frequently. This defined term is added to the title, and the text revision makes it clear that festoon lighting is also subject to this distance requirement, and it enhances electrical safety from shock hazards in the swimming pool area. The installation height is clarified to indicate that all parts must be above the minimum height. Additionally, "New" and "Installation" were removed from the title of 680.22(B)(1) to align the requirements with the remainder of this Section. 680.22(B)(4) is also revised to add festoon lighting to the requirement, to correlate with adding it to 680.22(B)(1).



Public Input No. 1648-NFPA 70-2023 [Section No. 680.22(B)(2)]

(2) Indoor Clearances.

For installations in indoor pool areas, the clearances shall be the same as for outdoor areas unless modified as provided in this paragraph. If the branch circuit supplying the equipment is protected by a ~~ground-fault circuit interrupter~~ GFCI, the following equipment shall be permitted at a height not less than 2.3 m (7 ft 6 in.) above the maximum pool water level:

- (1) Totally enclosed luminaires
- (2) Ceiling-suspended (paddle) fans identified for use beneath ceiling structures such as provided on porches or patios

Statement of Problem and Substantiation for Public Input

Section 2.1.2.9 of the NEC Style Manual permits the use of acronyms. The acronym, GFCI, is currently used in Article 100 and Section 680.5.

Submitter Information Verification

Submitter Full Name: Vincent Della Croce

Organization:

Street Address:

City:

State:

Zip:

Submittal Date: Thu Jul 27 16:23:24 EDT 2023

Committee: NEC-P17

Committee Statement

Resolution: [FR-9073-NFPA 70-2024](#)

Statement: Section 2.1.2.9 of the NEC Style Manual permits the use of acronyms. The acronym GFCI is defined in Article 100. An editorial revision was made for clarification to provide reference to 680.22(B)(1) for outdoor area clearances.



Public Input No. 1649-NFPA 70-2023 [Section No. 680.22(B)(3)]

(3) Existing Installations.

Existing luminaires and lighting outlets located less than 1.5 m (5 ft) measured horizontally from the inside walls of a pool shall be not less than 1.5 m (5 ft) above the surface of the maximum water level, shall be rigidly attached to the existing structure, and shall be protected by a ~~ground-fault circuit interrupter~~ GFCI.

Statement of Problem and Substantiation for Public Input

Section 2.1.2.9 of the NEC Style Manual permits the use of acronyms. The acronym, GFCI, is currently used in Article 100 and Section 680.5.

Submitter Information Verification

Submitter Full Name: Vincent Della Croce

Organization:

Street Address:

City:

State:

Zip:

Submittal Date: Thu Jul 27 16:26:02 EDT 2023

Committee: NEC-P17

Committee Statement

Resolution: [FR-9074-NFPA 70-2024](#)

Statement: Section 2.1.2.9 of the NEC Style Manual permits the use of acronyms. The acronym GFCI is defined in Article 100.



Public Input No. 4472-NFPA 70-2023 [Section No. 680.22(B)(8)]

(8) Measurements.

In determining the dimensions in this section addressing luminaires, the distance to be measured shall be the shortest path ~~an imaginary~~ the power-supply cord connected to the luminaire would follow without piercing a floor, wall, ceiling, ~~doorway with hinged or sliding door, window opening, or~~ other effective permanent barrier.

Statement of Problem and Substantiation for Public Input

A power-supply cord is a defined term in Article 100. This proposed change will make the language technically correct based on the Article 100 definition of "power-supply cord." Deleting "doorway with hinged sliding door, window opening" to match the requirement in 210.8 on how to measure, these requirements should be consistent.

Submitter Information Verification

Submitter Full Name: Mike Holt
Organization: Mike Holt Enterprises Inc
Street Address:
City:
State:
Zip:
Submittal Date: Thu Sep 07 16:05:47 EDT 2023
Committee: NEC-P17

Committee Statement

Resolution: In the context of 680.22(B)(8), the term "imaginary cord" is used as a reference to determine required distances, so changing it to power supply cord is not being made. The existing requirements regarding doorways and window openings are unique to pool/spa applications, and are not being deleted.



Public Input No. 1441-NFPA 70-2023 [Section No. 680.22(D)]

(D) Other Outlets.

Other outlets shall be not less than 3.0 m (10 ft) from the inside walls of the pool. Measurements shall be determined in accordance with 680.22(A)(5).

Informational Note: Other outlets ~~may~~ include, - ~~but~~ hardwired utilization equipment, but are not limited to, remote-control, signaling, fire alarm, and communications circuits.

Additional Proposed Changes

<u>File Name</u>	<u>Description</u>	<u>Approved</u>
284563822_532900028441467_122296014680546823_n.jpg	The other outlet is located at the hardwired utilization equipment	

Statement of Problem and Substantiation for Public Input

I do not agree that hardwired utilization equipment is defined as "other outlets" and applies to this section but the addition of the language would clarify this.

Submitter Information Verification

Submitter Full Name: William Snyder
Organization: RCC Solutions
Street Address:
City:
State:
Zip:
Submittal Date: Sun Jul 16 17:25:45 EDT 2023
Committee: NEC-P17

Committee Statement

Resolution: This informational note is not all-inclusive regarding outlet examples. Outlets are defined in Article 100 and includes connections to hardwired utilization equipment.



Public Input No. 3210-NFPA 70-2023 [Section No. 680.22(E)]

(E) ~~Other Equipment~~ Utilization Equipment and Appliances .

~~Other~~ **Utilization** equipment and appliances with ratings exceeding the low-voltage contact limit shall be located at least 1.5 m (5 ft) horizontally from the inside walls of a pool unless separated from the pool by a solid fence, wall, or other permanent barrier.

Statement of Problem and Substantiation for Public Input

The term 'Other Equipment' is vague and hard to enforce. Revising text to use defined terms 'Utilization Equipment' and 'Appliances' to properly apply this requirement. In accordance with the NEC Style manual section 3.2.1. "The documents shall not contain references or requirements that use unenforceable or vague terms."

Submitter Information Verification

Submitter Full Name: Mike Holt
Organization: Mike Holt Enterprises Inc
Street Address:
City:
State:
Zip:
Submittal Date: Wed Aug 30 11:27:26 EDT 2023
Committee: NEC-P17

Committee Statement

Resolution: The term "equipment" is defined in Article 100 and includes utilization equipment, appliances, and other equipment. Revising the term to "Utilization equipment and Appliances" instead of "Equipment" narrows the scope of equipment that is subject to these requirements and may reduce the level of safety.



Public Input No. 1453-NFPA 70-2023 [New Section after 680.23(A)(4)]

Maximum Voltage for New underwater Luminaries

(a) Maximum voltage for new underwater luminaries shall not exceed 30 volts.

Statement of Problem and Substantiation for Public Input

This will eliminate the shock and electrocution hazard of new underwater pool lights.

Submitter Information Verification

Submitter Full Name: Jason Scott

Organization: IES Residential

Affiliation: IEC

Street Address:

City:

State:

Zip:

Submittal Date: Mon Jul 17 11:47:39 EDT 2023

Committee: NEC-P17

Committee Statement

Resolution: Existing requirements in Section 680.23(A) provide for installation of pool lights at or below the low-voltage contact limit, and also for GFCI protection for luminaires above this voltage level. Substantiation has not been provided to show that the existing GFCI requirements do not provide sufficient protection.



Public Input No. 2334-NFPA 70-2023 [Section No. 680.23(A)(4)]

(4) Voltage Limitation.

No luminaires shall be installed for operation on supply circuits over 150 volts between conductors.

(5) For new underwater luminaires the maximum voltage shall not exceed 30 volts.

Statement of Problem and Substantiation for Public Input

This will eliminate the shock and electrocution hazard of new underwater pool luminaires.

Submitter Information Verification

Submitter Full Name: IEC National

Organization: IEC

Affiliation: Jason Scott IES residential

Street Address:

City:

State:

Zip:

Submittal Date: Wed Aug 16 13:00:21 EDT 2023

Committee: NEC-P17

Committee Statement

Resolution: Existing requirements in Section 680.23(A) provide for installation of pool lights at or below the low-voltage contact limit, and also for GFCI protection for luminaires above this voltage level. Substantiation has not been provided to show that the existing GFCI requirements do not provide sufficient protection.



Public Input No. 573-NFPA 70-2023 [Section No. 680.23(A)(4)]

(4) Voltage Limitation.

~~No luminaires~~ Luminaires shall not be installed ~~for operation~~ on supply circuits ~~over~~ exceeding 150 volts between conductors.

Statement of Problem and Substantiation for Public Input

This is an editorial revision made to provide consistency with other requirements in the Code.

Submitter Information Verification

Submitter Full Name: Ryan Jackson

Organization: Self-employed

Street Address:

City:

State:

Zip:

Submittal Date: Mon Apr 10 13:54:53 EDT 2023

Committee: NEC-P17

Committee Statement

Resolution: [FR-9084-NFPA 70-2024](#)

Statement: This is an editorial revision made to provide consistency with other requirements in the Code.



Public Input No. 1647-NFPA 70-2023 [Section No. 680.23(B)(2)]

(2) Wiring Extending Directly to the Forming Shell.

Conduit shall be installed from the forming shell to a junction box or other enclosure conforming to the requirements in 680.24. Conduit shall be rigid metal, intermediate metal, liquidtight flexible nonmetallic, or rigid polyvinyl chloride conduit.

- (a) *Metal Conduit.* Metal conduit shall be listed and shall be red brass or stainless steel.

Informational Note: See UL 6A, *Electrical Rigid Metal Conduit - Aluminum, Red Brass, and Stainless Steel*, for information on the listing criteria for red brass and stainless steel conduit.

(b) *Nonmetallic Conduit.* Where a nonmetallic conduit is used, an 8 AWG insulated solid or stranded copper bonding jumper shall be installed in this conduit unless a listed low-voltage lighting system not requiring grounding is used. The bonding jumper shall be terminated in the forming shell, junction box or transformer enclosure, or ~~ground-fault-circuit-interrupter enclosure~~ GFCI enclosure. The termination of the 8 AWG bonding jumper in the forming shell shall be covered with, or encapsulated in, a listed potting compound to protect the connection from the possible deteriorating effect of pool water.

Statement of Problem and Substantiation for Public Input

Section 2.1.2.9 of the NEC Style Manual permits the use of acronyms. The acronym, GFCI, is currently used in Article 100 and Section 680.5.

Submitter Information Verification

Submitter Full Name: Vincent Della Croce

Organization:

Street Address:

City:

State:

Zip:

Submittal Date: Thu Jul 27 16:19:43 EDT 2023

Committee: NEC-P17

Committee Statement

Resolution: [FR-9086-NFPA 70-2024](#)

Statement: Section 2.1.2.9 of the NEC Style Manual permits the use of acronyms. The acronym GFCI is defined in Article 100.



Public Input No. 2451-NFPA 70-2023 [Section No. 680.23(B)(6)]

(6) Servicing.

Wet-niche luminaires shall be removable from the water for inspection, relamping, or other maintenance. The forming shell location and length of cord in the forming shell shall permit personnel to place the removed luminaire on the deck or other dry location for such maintenance. The luminaire maintenance location shall be accessible without entering or going in the pool water.

~~In spa locations where wet-niche luminaires are installed low in the foot well of the spa, the luminaire shall only be required to reach the bench location, where the spa can be drained to make the bench location dry.~~

Statement of Problem and Substantiation for Public Input

Move the following spa language “In spa locations where wet-niche luminaires are installed low in the foot well of the spa, the luminaire shall only be required to reach the bench location, where the spa can be drained to make the bench location dry.” to Part IV Spas, Hot Tubs, and Permanently Installed Immersion Pools. Blending spa specific requirements with other articles can result in unnecessary confusion and missed opportunities for full compliance.

Submitter Information Verification

Submitter Full Name: Gary Hein

Organization: [Not Specified]

Street Address:

City:

State:

Zip:

Submittal Date: Thu Aug 17 12:32:02 EDT 2023

Committee: NEC-P17

Committee Statement

Resolution: CMP17 reaffirms that spas can be constructed as part of a permanently installed pool, or stand-alone. The existing requirement in 680.23(B)(6) addresses both types of constructions, due to 680.43(B)(2) referring back to 680.23. Therefore, moving the requirements from 680.23(B)(6) is not necessary.



Public Input No. 2269-NFPA 70-2023 [Section No. 680.23(F)(2)]

(2) Equipment Grounding Conductor .

Other than listed low-voltage luminaires not requiring grounding, all through-wall lighting assemblies, wet-niche, dry-niche, or no-niche luminaires shall be connected to an insulated copper equipment grounding conductor installed with the circuit conductors. The equipment grounding conductor shall be installed without joint or splice except as permitted in 680.23(F)(2)(a) and (F)(2)(b). The equipment grounding conductor shall be sized in accordance with 250.122 but shall not be smaller than 12 AWG.

Exception: An equipment grounding conductor between the wiring chamber of the secondary winding of a transformer and a junction box shall be sized in accordance with the transformer secondary overcurrent protection provided.

(a) If more than one underwater luminaire is supplied by the same branch circuit, the equipment grounding conductor, installed between the junction boxes, transformer enclosures, or other enclosures in the supply circuit to wet-niche luminaires, or between the field-wiring compartments of dry-niche luminaires, shall be permitted to be terminated on grounding terminals.

(b) If the underwater luminaire is supplied from a transformer, ground-fault circuit interrupter, clock-operated switch, or a manual snap switch that is located between the panelboard and a junction box connected to the conduit that extends directly to the underwater luminaire, the equipment grounding conductor shall be permitted to terminate on grounding terminals on the transformer, ground-fault circuit interrupter, clock-operated switch enclosure, or an outlet box used to enclose a snap switch.

Statement of Problem and Substantiation for Public Input

Changing the title would make the text technically correct. This requirement is about having an equipment grounding conductor of the wire type for the branch circuit wiring, not about grounding. In accordance with NEC style manual section 2.1.3.2 the title must be descriptive and concise with the intent of the requirement.

Submitter Information Verification

Submitter Full Name: Mike Holt
Organization: Mike Holt Enterprises Inc
Street Address:
City:
State:
Zip:
Submittal Date: Tue Aug 15 14:32:43 EDT 2023
Committee: NEC-P17

Committee Statement

Resolution: Adding the word “conductor” to the title of 680.23(F)(2) would not provide significant clarification and may cause confusion.



Public Input No. 1651-NFPA 70-2023 [Section No. 680.24(B) [Excluding any Sub-Sections]]

An enclosure for a transformer, ~~ground-fault circuit interrupter~~ GFCI , or a similar device connected to a conduit that extends directly to a forming shell or mounting bracket of a no-niche luminaire shall meet the requirements of this section.

Statement of Problem and Substantiation for Public Input

Section 2.1.2.9 of the NEC Style Manual permits the use of acronyms. The acronym, GFCI, is currently used in Article 100 and Section 680.5.

Submitter Information Verification

Submitter Full Name: Vincent Della Croce

Organization:

Street Address:

City:

State:

Zip:

Submittal Date: Thu Jul 27 16:28:40 EDT 2023

Committee: NEC-P17

Committee Statement

Resolution: FR-9090-NFPA 70-2024

Statement: Section 2.1.2.9 of the NEC Style Manual permits the use of acronyms. The acronym GFCI is defined in Article 100.



Public Input No. 1652-NFPA 70-2023 [Section No. 680.24(D)]

(D) Grounding Terminals.

Junction boxes, transformer and power-supply enclosures, and ~~ground-fault-circuit-interrupter enclosures~~ GFCI enclosures connected to a conduit that extends directly to a forming shell or mounting bracket of a no-niche luminaire shall be provided with a number of grounding terminals that shall be no fewer than one more than the number of conduit entries.

Statement of Problem and Substantiation for Public Input

Section 2.1.2.9 of the NEC Style Manual permits the use of acronyms. The acronym, GFCI, is currently used in Article 100 and Section 680.5.

Submitter Information Verification

Submitter Full Name: Vincent Della Croce

Organization:

Street Address:

City:

State:

Zip:

Submittal Date: Thu Jul 27 16:30:55 EDT 2023

Committee: NEC-P17

Committee Statement

Resolution: [FR-9099-NFPA 70-2024](#)

Statement: The text of 680.24(D) was editorially revised for clarity. Section 2.1.2.9 of the NEC Style Manual permits the use of acronyms. The acronym GFCI is currently defined in Article 100.

Relocating 680.24(F) to 680.24(D)(2) to group these similar requirements together. Both 680.24(D) and (F) have requirements relating to grounding terminals, therefore this relocation will add clarity for Code users.



Public Input No. 3211-NFPA 70-2023 [Section No. 680.24(D)]

(D) Grounding Terminals.

(1) Number of Grounding Terminals. Junction boxes, transformer and power-supply enclosures, and ground-fault circuit-interrupter enclosures connected to a conduit that extends directly to a forming shell or mounting bracket of a no-niche luminaire shall be provided with a number of grounding terminals that shall be no fewer than one more than the number of conduit entries.

(2) Connected to Panelboard Enclosure. The grounding terminals of a junction box, transformer enclosure, or other enclosure in the supply circuit to a wet-niche or no-niche luminaire and the field-wiring chamber of a dry-niche luminaire shall be connected to the equipment grounding terminal of the panelboard. This terminal shall be directly connected to the panelboard enclosure.

Statement of Problem and Substantiation for Public Input

Relocating 680.24(F) to 680.24(D)(2) to group these similar requirements together. Both 680.24(D) and (F) have requirements relating to grounding terminals, therefore this relocation will add clarity for Code users. Submitting another public input to delete 680.24(F).

Submitter Information Verification

Submitter Full Name: Mike Holt
Organization: Mike Holt Enterprises Inc
Street Address:
City:
State:
Zip:
Submittal Date: Wed Aug 30 11:36:00 EDT 2023
Committee: NEC-P17

Committee Statement

Resolution: [FR-9099-NFPA 70-2024](#)

Statement: The text of 680.24(D) was editorially revised for clarity. Section 2.1.2.9 of the NEC Style Manual permits the use of acronyms. The acronym GFCI is currently defined in Article 100.

Relocating 680.24(F) to 680.24(D)(2) to group these similar requirements together. Both 680.24(D) and (F) have requirements relating to grounding terminals, therefore this relocation will add clarity for Code users.



Public Input No. 1654-NFPA 70-2023 [Section No. 680.24(E)]

(E) Strain Relief.

The termination of a flexible cord of an underwater luminaire within a junction box, transformer or power-supply enclosure, ~~ground-fault circuit interrupter~~ GFCI, or other enclosure shall be provided with a strain relief.

Statement of Problem and Substantiation for Public Input

Section 2.1.2.9 of the NEC Style Manual permits the use of acronyms. The acronym, GFCI, is currently used in Article 100 and Section 680.5.

Submitter Information Verification

Submitter Full Name: Vincent Della Croce

Organization:

Street Address:

City:

State:

Zip:

Submittal Date: Thu Jul 27 16:32:59 EDT 2023

Committee: NEC-P17

Committee Statement

Resolution: [FR-9103-NFPA 70-2024](#)

Statement: Section 2.1.2.9 of the NEC Style Manual permits the use of acronyms. The acronym GFCI is defined in Article 100. The word “enclosure” after GFCI was added for clarity, as this section relates to strain reliefs for enclosures.



Public Input No. 2082-NFPA 70-2023 [Section No. 680.24(F)]

(F) Grounding.

The grounding terminals of a junction box, transformer enclosure, or other enclosure in the supply circuit to a wet-niche or no-niche luminaire and the field-wiring chamber of a dry-niche luminaire shall be connected to the equipment grounding terminal of the enclosed panelboard. This terminal shall be directly connected to the panelboard enclosure.

Statement of Problem and Substantiation for Public Input

The term 'panelboard' and 'enclosed panelboard' are defined terms. Adding the word 'enclosed panelboard' makes the text technically correct. Note: The term 'Enclosed Panelboard' was added to NEC Article 100 during the 2023 Code cycle.

Submitter Information Verification

Submitter Full Name: Mike Holt
Organization: Mike Holt Enterprises Inc
Street Address:
City:
State:
Zip:
Submittal Date: Fri Aug 11 15:33:15 EDT 2023
Committee: NEC-P17

Committee Statement

Resolution: [FR-9099-NFPA 70-2024](#)

Statement: The text of 680.24(D) was editorially revised for clarity. Section 2.1.2.9 of the NEC Style Manual permits the use of acronyms. The acronym GFCI is currently defined in Article 100.

Relocating 680.24(F) to 680.24(D)(2) to group these similar requirements together. Both 680.24(D) and (F) have requirements relating to grounding terminals, therefore this relocation will add clarity for Code users.



Public Input No. 3212-NFPA 70-2023 [Section No. 680.24(F)]

~~(F) Grounding:~~

~~The grounding terminals of a junction box, transformer enclosure, or other enclosure in the supply circuit to a wet-niche or no-niche luminaire and the field-wiring chamber of a dry-niche luminaire shall be connected to the equipment grounding terminal of the panelboard. This terminal shall be directly connected to the panelboard enclosure.~~

Statement of Problem and Substantiation for Public Input

Submitted another public input to group 680.24(D) and (F) together since both have similar requirements. This will add clarity to Code users.

Submitter Information Verification

Submitter Full Name: Mike Holt
Organization: Mike Holt Enterprises Inc
Street Address:
City:
State:
Zip:
Submittal Date: Wed Aug 30 11:38:27 EDT 2023
Committee: NEC-P17

Committee Statement

Resolution: [FR-9099-NFPA 70-2024](#)

Statement: The text of 680.24(D) was editorially revised for clarity. Section 2.1.2.9 of the NEC Style Manual permits the use of acronyms. The acronym GFCI is currently defined in Article 100.

Relocating 680.24(F) to 680.24(D)(2) to group these similar requirements together. Both 680.24(D) and (F) have requirements relating to grounding terminals, therefore this relocation will add clarity for Code users.



Public Input No. 212-NFPA 70-2023 [Section No. 680.26(A)]

(A) Performance.

The equipotential bonding required by 680.26(B) and (C) to reduce voltage gradients in the pool area shall be installed for pools with or without associated electrical equipment related to the pool.

Informational Note No. 1: Some causes of voltage gradients originate outside the premises wiring system and are not within the scope of the NEC. Measures identified in Rule 097D2 of ANSI C2, National Electrical Safety Code can also serve to address voltage gradients originating on the utility side of the service point.

Informational Note No. 2: By its nature, equipotential bonding of swimming pools and perimeter surfaces involves contact between various metallic materials and the earth. This can, in some cases, expose various specific metals to a corrosive environment, depending on factors such as the type and chemical content of the soil and the specific metal. Corrosive environments are also addressed in 680.14.

-

Statement of Problem and Substantiation for Public Input

This addition of two Informational Notes to NEC 680.26(A) was approved by the Task Group addressing TIA 1867 for the 2023 Edition, and is submitted for consideration by CMP-17 as a companion to the Task Group recommendations for changes to NEC 100 (Definition of "Pool") and NEC 680.26(B)(2), in the event the TIA is not adopted.

The Task Group's substantiation for the change herein is as follows (including the introductory material) and is submitted as substantiation for this change (copied from the TIA submission):

"This Tentative Interim Amendment (TIA) is proposed by a Task Group appointed by NFPA staff pursuant to the decision of the Standards Council D#22-3 on Agenda item SC#22-8-5-w-1 as voted 12 August 2022. This decision denied the underlying appeal, but found that issues raised at the hearing relative to current research and loss experience required "timely analysis." Given the "highly technical nature" of the subject matter, the Council directed that this Task Group be one that was "balanced" and that possessed the technical expertise to evaluate the relevant research. As there is considerable controversy over this issue, the focus was reaching common ground which would result in a practical compromise acceptable to the participants.

"The Task Group focused its attention on 680.26(B)(2) which covers the bonding of the surfaces that make up the perimeter of a swimming pool. After extensive discussion, the Task Group is proposing a complete rewrite of this material, as well as related material within the scope of CMP 17. The detailed substantiation follows:

[Regarding changes to 680.26(A)] "The Task Group is also suggesting new Informational Notes in 680.26(A) that address general performance issues. The Task Group emphasizes that the potential hazard in these areas results from voltage gradients in the earth that can pose unique hazards to persons entering or exiting a swimming pool or to persons simultaneously in contact with the perimeter surface and the pool water, because wet skin has substantially decreased resistance to electric current.

"The Task Group is aware that these gradients can originate on either side of the service point, including on the utility side of that point. A new informational note points to the lack of jurisdiction of the NEC in such cases, and identifies the NESC provisions that can allow for reduction or elimination of such gradients from that source. A second informational note points

to the effects that corrosive environments can have on electrical components, including bonding connections."

Related Public Inputs for This Document

<u>Related Input</u>	<u>Relationship</u>
Public Input No. 213-NFPA 70-2023 [Section No. 680.26(B)(2)]	Companion submittal originally incorporated as part of TIA.
Public Input No. 211-NFPA 70-2023 [Definition: Pool.]	Companion submittal originally incorporated as part of TIA.
Public Input No. 211-NFPA 70-2023 [Definition: Pool.]	
Public Input No. 213-NFPA 70-2023 [Section No. 680.26(B)(2)]	

Submitter Information Verification

Submitter Full Name: E. P. Hamilton
Organization: E. P. Hamilton & Associates, Inc
Street Address:
City:
State:
Zip:
Submittal Date: Sat Jan 21 18:06:06 EST 2023
Committee: NEC-P17

Committee Statement

Resolution: [FR-9239-NFPA 70-2024](#)

Statement: Revisions to this section include:

Informational Note 1 to 680.26(A) was revised to comply with 2.1.10 of the NEC Style Manual.

Informational Note 2 to 680.26(A) was deleted as it did not add clarity to the requirements. Corrosive environments are already addressed in 680.14, and performance requirements are already addressed in 680.26(A). Therefore, this language is not needed.

Section 680.26(B) was editorially revised into a list format for ease of reading, in accordance with 3.5.2 of the NEC Style Manual. New text was added to clarify that structural reinforcing steel and steel structural welded wire reinforcement are permitted options for bonding. These options were inferred but not explicitly stated.

Section 680.26(B) was revised by changing "panelboard" to "panelboard enclosure" for accuracy.

Multiple editorial changes were made to 680.26(B)(2) for clarification and readability; and redundant language, including 680.26(B)(2)(d), was eliminated. The word "conductor" was added to the phrase "copper grid" in multiple locations for consistency, as was adding the word "structural" to the phrase "reinforcing steel."

An allowance for a copper conductor grid was added in 680.26(B)(2)(a)(2) because a copper conductor grid should be a permitted method of achieving the bonding contemplated in this section.



Public Input No. 3253-NFPA 70-2023 [Section No. 680.26(A)]

(A) Performance.

The equipotential bonding required by 680.26(B) and (C) to reduce voltage gradients in the pool area shall be installed for pools with or without associated electrical equipment related to the pool.

Informational Note No. 1: Some causes of voltage gradients originate outside the premises wiring system and are not within the scope of the *NEC*. Measures identified in Rule 097D2 of ANSI C2, *National Electrical Safety Code*, can also serve to address voltage gradients originating on the utility side of the service point.

~~Informational Note No. 2: By its nature, equipotential bonding of swimming pools and perimeter surfaces involves contact between various metallic materials and the earth. This can, in some cases, expose various specific metals to a corrosive environment, depending on factors such as the type and chemical content of the soil and the specific metal. Corrosive environments are also addressed in 680.14.~~

Statement of Problem and Substantiation for Public Input

Delete Informational Note No. 2. It's statement that the nature of equipotential bonding of swimming pools and perimeter surfaces can expose various specific metals to a corrosive environment make no sense and the reference to 680.14 is even more confusing. This note needs to be deleted because it makes a statement about corrosion when this topic (corrosion) is already address in Article 680.

Submitter Information Verification

Submitter Full Name: Mike Holt
Organization: Mike Holt Enterprises Inc
Street Address:
City:
State:
Zip:
Submittal Date: Wed Aug 30 17:42:26 EDT 2023
Committee: NEC-P17

Committee Statement

Resolution: [FR-9239-NFPA 70-2024](#)

Statement: Revisions to this section include:

Informational Note 1 to 680.26(A) was revised to comply with 2.1.10 of the NEC Style Manual.

Informational Note 2 to 680.26(A) was deleted as it did not add clarity to the requirements. Corrosive environments are already addressed in 680.14, and performance requirements are already addressed in 680.26(A). Therefore, this language is not needed.

Section 680.26(B) was editorially revised into a list format for ease of reading, in accordance with 3.5.2 of the NEC Style Manual. New text was added to clarify that

structural reinforcing steel and steel structural welded wire reinforcement are permitted options for bonding. These options were inferred but not explicitly stated.

Section 680.26(B) was revised by changing “panelboard” to “panelboard enclosure” for accuracy.

Multiple editorial changes were made to 680.26(B)(2) for clarification and readability; and redundant language, including 680.26(B)(2)(d), was eliminated. The word “conductor” was added to the phrase “copper grid” in multiple locations for consistency, as was adding the word “structural” to the phrase “reinforcing steel.”

An allowance for a copper conductor grid was added in 680.26(B)(2)(a)(2) because a copper conductor grid should be a permitted method of achieving the bonding contemplated in this section.



Public Input No. 1125-NFPA 70-2023 [Section No. 680.26(B)(1)]

(1) Conductive Pool Shells.

Bonding to conductive pool shells shall be provided as specified in 680.26(B)(1)(a) or (B)(1)(b). Cast-in-place concrete, pneumatically applied or sprayed concrete, and concrete block with painted or plastered coatings shall all be considered conductive materials due to water permeability and porosity. Reconstructed pool shells shall also meet the requirements of this section. Vinyl liners and fiberglass composite shells shall be considered to be nonconductive materials and not subject to these requirements.

(a) - ~~Structural Reinforcing Steel. Unencapsulated structural reinforcing steel shall~~ Rebar. Unencapsulated rebar shall be bonded together by steel tie wires or the equivalent. Where ~~structural reinforcing steel is~~ rebar is encapsulated in a nonconductive compound, a copper conductor grid shall be installed in accordance with 680.26(B)(1)(b). Metal components shall be encased by at least 50 mm (2 in.) of concrete and shall be located within that portion of a concrete foundation or footing that is in direct contact with the earth

(b) *Copper Conductor Grid.* A copper conductor grid shall be provided and shall comply with the following:

- (3) Be constructed of minimum 8 AWG bare solid copper conductors bonded to each other at all points of crossing in accordance with 250.8 or other approved means
- (4) Conform to the contour of the pool
- (5) Be arranged in a 300 mm (12 in.) by 300 mm (12 in.) network of conductors in a uniformly spaced perpendicular grid pattern with a tolerance of 100 mm (4 in.)
- (6) Be secured within or under the pool no more than 150 mm (6 in.) from the outer contour of the pool shell

Statement of Problem and Substantiation for Public Input

Replaced Structural reinforcing steel with rebar to keep consistency with other sections of this code. Added language from 250.52(A)(3)(1) to add clarity. As an alternate, the code panel could replace the new language with the code citation.

Submitter Information Verification

Submitter Full Name: Greg Chontow
Organization: Boro of Hopatcong, NJ
Street Address:
City:
State:
Zip:
Submittal Date: Mon Jun 19 07:02:41 EDT 2023
Committee: NEC-P17

Committee Statement

Resolution: The proposed language does not add clarity. Structural reinforcing steel is the more general term which includes, but is not limited to, steel rebar, and which makes it clear as to the nature of the material. Rebar, on the other hand, may include some reinforcing materials which are not steel, and which are non-conductive and unsuitable for the bonding application (e.g., fiberglass rebar).



Public Input No. 2019-NFPA 70-2023 [Section No. 680.26(B)(1)]

(1) Conductive Pool Shells.

Bonding to conductive pool shells shall be provided as specified in 680.26(B)(1)(a) or (B)(1)(b). Cast-in-place concrete, pneumatically applied or sprayed concrete, and concrete block with painted or plastered coatings shall all be considered conductive materials due to water permeability and porosity. Reconstructed pool shells shall also meet the requirements of this section. Vinyl liners and fiberglass composite shells shall be considered to be nonconductive materials and not subject to these requirements.

(a) *Structural Reinforcing Steel.* Unencapsulated structural reinforcing steel shall be bonded together by steel tie wires or the equivalent. Where structural reinforcing steel is encapsulated in a nonconductive compound, a copper conductor grid shall be installed in accordance with 680.26(B)(1)(b):

(b) ~~Copper Conductor~~ Conductor Grid. A copper or 40% copper-clad steel conductor grid shall be provided and shall comply with the following:

- (3) Be constructed of minimum 8 AWG bare solid copper or copper-clad steel conductors bonded to each other at all points of crossing in accordance with 250.8 or other approved means
- (4) Conform to the contour of the pool
- (5) Be arranged in a 300 mm (12 in.) by 300 mm (12 in.) network of conductors in a uniformly spaced perpendicular grid pattern with a tolerance of 100 mm (4 in.)
- (6) Be secured within or under the pool no more than 150 mm (6 in.) from the outer contour of the pool shell

Statement of Problem and Substantiation for Public Input

Please see the technical substantiation in Public Input 1102.

Submitter Information Verification

Submitter Full Name: Peter Graser
Organization: Copperweld
Affiliation: American Bimetallic Association
Street Address:
City:
State:
Zip:
Submittal Date: Fri Aug 11 07:27:30 EDT 2023
Committee: NEC-P17

Committee Statement

Resolution: CMP17 has concerns including corrosion at the ends of copper-clad steel conductors and copper-clad reinforcing steel installed in concrete, earth, or other corrosive environments. CMP17 also requests data showing how the product reacts to exothermic welding, as that process is a permitted method of connection in this section.



Public Input No. 1214-NFPA 70-2023 [New Section after 680.26(B)(2)]

TITLE OF NEW CONTENT

Type your content here ...Bonding of the area outside the metal fence will avoid gradients from that area to the fence.

-

Statement of Problem and Substantiation for Public Input

By bonding the perimeter outside the fence it would eliminate any chance of a potential between the fence and the perimeter.

Submitter Information Verification

Submitter Full Name: Lou Petrucci

Organization: [Not Specified]

Street Address:

City:

State:

Zip:

Submittal Date: Tue Jun 27 13:12:13 EDT 2023

Committee: NEC-P17

Committee Statement

Resolution: The proposed PI contains no enforceable code language. Section 680.26 presently requires equipotential bonding for the area in proximity to a pool. Insufficient technical substantiation has been presented to support the proposed change.



Public Input No. 3460-NFPA 70-2023 [New Section after 680.26(B)(2)]

TITLE OF NEW CONTENT

Type your content here ...Structural rebar that is not encased in concrete shall not be permitted to be extended outside of the pool concrete for equipotential bonding connections.

Statement of Problem and Substantiation for Public Input

un-protected rebar extensions outside of the concrete for equipotential bonding connections are subject to corrosive conditions that will compromise the performance of the equipotential bonding system. A pool area is a corrosive environment per definition and this provision will protect the integrity of the rebar and bonding connections to rebar. NEC 250.68 (C) (3) only allows rebar extensions in accessible locations that are not subject to corrosion and not exposed to the earth, this same requirement needs to apply to pool rebar extensions. NEC 680.7 (C) requires all field installed terminals to be listed for direct burial use, direct burial connectors to an unprotected extension of rebar defeats the purpose. This change will allow inspectors at bonding inspections to verify bond connections to rebar are within the pool concrete.

Submitter Information Verification

Submitter Full Name: Michael Dempsey
Organization: Trinity Code Inspections
Street Address:
City:
State:
Zip:
Submittal Date: Sun Sep 03 09:38:35 EDT 2023
Committee: NEC-P17

Committee Statement

Resolution: Multiple varieties of corrosion-resistant structural reinforcing steel and rebar (e.g., stainless steel, galvanized) exist. Structural rebar has been an accepted method of perimeter bonding including not encased in concrete for many years with acceptable performance. Insufficient technical substantiation has been presented to support the proposed change.



Public Input No. 1738-NFPA 70-2023 [Section No. 680.26(B)(2)]

(2) Perimeter Surfaces.

Bonding to perimeter surfaces shall be provided as specified in 680.26(B)(2)(a), (B)(2)(b), (B)(2)(c), and (B)(2)(d). The perimeter surface shall include unpaved surfaces, concrete, masonry pavers and other types of paving. The perimeter surface to be bonded shall be considered to extend for 900 mm (3-ft 3 in) horizontally beyond the inside walls of the pool while also at a height between 900 mm (3-ft 3 in) above and 600-1200 mm (2-4 ft) below the maximum water level. ~~The perimeter surface shall include unpaved surfaces, concrete, and other types of paving.~~ Perimeter surfaces separated from the pool by a permanent wall ~~or of~~ building 1.5 m (5-ft 5 in) (5 ft) in height or more shall require equipotential bonding only on the pool side of the permanent wall ~~or building~~. ~~Bonding to perimeter surfaces shall be provided as specified in 680.26(B)(2)(a), (B)(2)(b), (B)(2)(c), and (B)(2)(d).~~ or building.

For conductive pool shells where bonding to perimeter surfaces is required, it shall be attached to the pool structural reinforcing steel or copper conductor grid at a minimum of four points uniformly spaced around the perimeter of the pool; ~~or if~~. If the bonded perimeter surface does not surround the entire pool, it shall be attached to the pool structural reinforcing steel or copper conductor grid at a minimum of four uniformly spaced points along the bonded perimeter surface.

For nonconductive pool shells, ~~where bonding to the perimeter surfaces is required, bonding~~ at four points shall not be required, ~~and the~~. The perimeter bonding shall be attached to the 8 AWG copper equipotential bonding conductor and, if present, to any conductive support structure for the pool.

Informational Note: Because the perimeter surface can incorporate various types of materials at various locations and elevations above and below maximum water level, the perimeter surface required to be bonded might not surround the entire pool. The 8 AWG copper equipotential bonding conductor can encircle the entire pool to facilitate connection of bonded parts.

(a) Conductive Paved Portions of Perimeter Surfaces. Conductive paved portions of perimeter surfaces, ~~including masonry pavers, if used,~~ shall be bonded with one or more of the following

(b) (1) unencapsulated structural reinforcing steel in accordance with 680.26(B)(1)1 (a), ~~or with~~

(c) (2) a copper conductor grid

(d) (3) unencapsulated steel structural welded wire reinforcement (welded wire mesh, welded wire fabric), bonded reinforcement bonded together by steel tie wires or the equivalent. ~~Steel welded wire reinforcement shall be~~, and fully embedded within the pavement unless the pavement will not allow for embedding.

(e) If the reinforcing steel is absent, or is encapsulated in a nonconductive compound, or embedding is not possible, unencapsulated welded wire steel reinforcement or a copper conductor grid shall be provided and shall be secured directly under the paving, and not more than 150 mm (6 in.) below finished grade.

(f)

~~Unencapsulated~~ Unencapsulated structural steel welded wire reinforcement that is not fully embedded in concrete, and a copper conductor grid regardless of location, where used for equipotential bonding, shall be listed for corrosion resistance and mechanical performance. This listing requirement shall become effective January 1, 2025. The copper conductor grid or ~~unencapsulated~~ unencapsulated structural steel welded wire reinforcement shall also meet the following:

- (1) Copper grid is constructed of 8 AWG solid bare copper and arranged in accordance with 680.26(B)(1)(b)(3).
- (2) ~~Steel~~ Structural steel welded wire reinforcement is minimum ASTM 6 × 6-W2.0 × W2.0 or minimum No. 3 rebar constructed in a 300 mm (12 in.) grid.
- (3) Copper conductor grid and structural steel welded wire reinforcement follow the contour of the perimeter surface extending not less than 900 mm (3 ft) horizontally beyond the inside walls of the pool:
- (4) ~~Only listed splicing devices or exothermic welding are used.~~

~~Informational Note No. 1: Performance of the equipotential bonding system at the perimeter surface is improved as the distance between the bonding means and finished grade is minimized, either by embedding within, or by direct contact with the underside of, the finished pavement.~~

Informational Note No. 2: See ASTM A615/A615M, *Standard Specification for Deformed and Plain Carbon-Steel Bars for Concrete Reinforcement*; A1064/A1064M, *Standard Specification for Carbon-Steel Wire and Welded Wire Reinforcement, Plain and Deformed, for Concrete*; A1022/A1022M, *Standard Specification for Deformed and Plain Stainless Steel Wire and Welded Wire for Concrete Reinforcement*; A1060A/A1060M, *Standard Specification for Zinc-Coated (Galvanized) Steel Welded Wire Reinforcement, Plain and Deformed, for Concrete*; and ACI Standard ACI 318, *Building Code Requirements for Structural Concrete*, for examples of standards currently used in the listing of reinforcing steel bars and steel welded wire reinforcement.

(g) *Unpaved Portions of Perimeter Surfaces*. Unpaved portions of perimeter surfaces shall be bonded with any of the following methods:

- (8) Copper conductor(s) shall meet the following:
 - (9) At least one minimum 8 AWG bare solid copper conductor, including the 8 AWG copper equipotential bonding conductor if available.
 - (10) The conductors follow the contour of the perimeter surface.

(11) ~~Only listed splicing devices or exothermic welding are used.~~

(1)

- a. The conductor(s) is 450 mm to 600 mm (18 in. to 24 in.) from the inside walls of the pool.
- b. The conductor(s) is under the unpaved portion of the perimeter surface 100 mm to 150 mm (4 in. to 6 in.) below finished grade.
- c. Be installed only in perimeter surfaces not intended to have direct access to swimmers in the pool.

Copper

(1) Copper conductor grid or

~~unencapsulated~~

(1) unencapsulated structural steel welded wire reinforcement used for equipotential bonding of unpaved portions of perimeter surfaces shall meet the following:

(12) Be installed in accordance with 680.26(B)(2)(a).

(13) Be located within unpaved surface(s) between 100 mm to 150 mm (4 in. to 6 in.) below finished grade.

(n) *Nonconductive Perimeter Surfaces.* Equipotential bonding shall not be required for nonconductive portions of perimeter surfaces that are separated from earth or raised on nonconducting supports, ~~and it~~. Equipotential bonding shall not be required for any perimeter surface that is electrically separated from the pool structure and raised on nonconductive supports above an equipotentially bonded surface.

Informational Note: Nonconductive materials include, but are not limited to, wood, plastic, wood-plastic composites, fiberglass, and fiberglass composites.

(o) *Interconnection of Bonded Portions of Perimeter Surfaces.* ~~All surfaces where equipotential bonding is required shall be interconnected using listed splicing devices or exothermic welding. Where copper wire is used for this purpose, it shall be~~ The solid copper, not smaller than 8 AWG ~~The~~ conductor shall be permitted to encircle the pool to facilitate bonding connections to portions of the perimeter covered in 680.26(B)(2)(a) and (B)(2)(b) that are not contiguous.

Additional Proposed Changes

<u>File Name</u>	<u>Description</u>	<u>Approved</u>
680.26_C_re-write_all_changes_accepted.docx	680.26(B)(2) proposed revisions	
pool_perimeter_surface_different_elevations.jpg	pool perimeter surface	

Statement of Problem and Substantiation for Public Input

Terra has made the proposed changes difficult to view, see the attached word doc for a clean version. Also, no informational notes are proposed to be revised or deleted as shown in Terra.

This PI proposes to restructure this section as well as make technical revisions:

- 1- the references to (B)(2)(a) through (d) are moved to the beginning of the section for clarity
- 2- the reference to "masonry pavers" is relocated from (B)(2)(a) to the beginning of (B)(2) and included in the types of paving sentence to consolidate similar information
- 3- multiple areas are put into a list format, and separate sentences are introduced for clarity
- 4- for correlation and consistency, changes are made to reference "structural reinforcing steel", "copper conductor grid" and "structural steel welded wire reinforcement"
- 5- references to "listed splicing devices" and "exothermic welding" are deleted as the parent language of 680.26(B) already includes a reference to 250.8 (and 680.7 if PI 1737 moves forward)
- 6- The perimeter surface measurement is revised to 4' below the maximum water level to protect persons standing on a conductive surface while also being able to put their hands and arms into a pool. See the attached picture of a pool where the design makes this possible. If there is a shock hazard in the perimeter surface that is even with the top of the pool and the same shock hazard is present at the lower surface, is there a concern for protection of the person who just left the pool and walked over to the lower surface? Current requirements protect the person while in the pool in this scenario, but not while standing outside the pool on the lower surface.

Submitter Information Verification

Submitter Full Name: Vincent Della Croce

Organization:

Street Address:

City:

State:

Zip:

Submittal Date: Mon Jul 31 14:05:30 EDT 2023

Committee: NEC-P17

Committee Statement

Resolution: [FR-9257-NFPA 70-2024](#)

Statement: Revisions were made to change the height parameter in 680.26(B)(2) for the perimeter surface from 600 mm (2 ft) below maximum water level to 900 mm (3 ft) below maximum water level to more accurately address the reach range for a person using the pool.

(B) Bonded Parts.

The parts specified in 680.26(B)(1) through (B)(7) shall be bonded together using one or more of the following

- (1) solid copper conductors, insulated, covered, or bare, not smaller than 8 AWG, which shall not be required to be extended or attached to remote panelboards, service equipment, or electrodes
- (2) rigid metal conduit of brass or other identified corrosion-resistant metal
- (3) structural reinforcing steel
- (4) steel structural welded wire reinforcement (welded wire mesh, welded wire fabric)

Connections to bonded parts shall be made in accordance with 250.8 and 680.7(C).

(2) Perimeter Surfaces.

Bonding to perimeter surfaces shall be provided as specified in 680.26(B)(2)(a), (B)(2)(b), (B)(2)(c), and (B)(2)(d). The perimeter surface shall include unpaved surfaces, concrete, masonry pavers and other types of paving. The perimeter surface to be bonded shall be considered to extend for 900 mm (3 ft) horizontally beyond the inside walls of the pool while also at a height between 900 mm (3 ft) above and 1200mm (4 ft) below the maximum water level. Perimeter surfaces separated from the pool by a permanent wall or building 1.5 m (5 ft) in height or more shall require equipotential bonding only on the pool side of the permanent wall or building.

For conductive pool shells where bonding to perimeter surfaces is required, it shall be attached to the pool structural reinforcing steel or copper conductor grid at a minimum of four points uniformly spaced around the perimeter of the pool, If the bonded perimeter surface does not surround the entire pool, it shall be attached to the pool structural reinforcing steel or copper conductor grid at a minimum of four uniformly spaced points along the bonded perimeter surface.

For nonconductive pool shells, bonding at four points shall not be required. The perimeter bonding shall be attached to the 8 AWG copper equipotential bonding conductor and, if present, to any conductive support structure for the pool.

Informational Note: Because the perimeter surface can incorporate various types of materials at various locations and elevations above and below maximum water level, the perimeter surface required to be bonded might not surround the entire pool. The 8 AWG copper equipotential bonding conductor can encircle the entire pool to facilitate connection of bonded parts.

- (a) Conductive Paved Portions of Perimeter Surfaces. Conductive paved portions of perimeter surfaces shall be bonded with one or more of the following
- (1) unencapsulated structural reinforcing steel in accordance with 680.26(B)(1)(a),
 - (2) a copper conductor grid,
 - (3) unencapsulated steel structural welded wire reinforcement bonded together by steel tie wires or the equivalent, and fully embedded within the pavement unless the pavement will not allow for embedding .

If the structural reinforcing steel is absent, or is encapsulated in a nonconductive compound, or embedding is not possible, unencapsulated welded wire steel reinforcement or a copper conductor grid shall be provided and shall be secured directly under the paving, and not more than 150 mm (6 in.) below finished grade.

Unencapsulated structural steel welded wire reinforcement that is not fully embedded in concrete, and a copper conductor grid regardless of location, where used for equipotential bonding, shall be listed for corrosion resistance and mechanical performance. This listing requirement shall become effective January 1, 2025. The copper conductor grid or unencapsulated structural steel welded wire reinforcement shall also meet the following:

(1) Copper conductor grid is constructed of 8 AWG solid bare copper and arranged in accordance with 680.26(B)(1)(b)(3).

(2) Structural steel welded wire reinforcement is minimum ASTM 6 × 6-W2.0 × W2.0 or minimum No. 3 rebar constructed in a 300 mm (12 in.) grid.

(3) Copper conductor grid and structural steel welded wire reinforcement follow the contour of the perimeter surface extending not less than 900 mm (3 ft) horizontally beyond the inside walls of the pool.

Informational Note No. 1: Performance of the equipotential bonding system at the perimeter surface is improved as the distance between the bonding means and finished grade is minimized, either by embedding within, or by direct contact with the underside of, the finished pavement.

Informational Note No. 2: See ASTM A615/A615M, Standard Specification for Deformed and Plain Carbon-Steel Bars for Concrete Reinforcement; A1064/A1064M, Standard Specification for Carbon-Steel Wire and Welded Wire Reinforcement, Plain and Deformed, for Concrete; A1022/A1022M, Standard Specification for Deformed and Plain Stainless Steel Wire and Welded Wire for Concrete Reinforcement; A1060A/A1060M, Standard Specification for Zinc-Coated (Galvanized) Steel Welded Wire Reinforcement, Plain and Deformed, for Concrete; and ACI Standard ACI 318, Building Code Requirements for Structural Concrete, for examples of standards currently used in the listing of reinforcing steel bars and steel welded wire reinforcement.

(b) Unpaved Portions of Perimeter Surfaces. Unpaved portions of perimeter surfaces shall be bonded with any of the following methods:

(1) Copper conductor(s) shall meet the following:

(a) At least one minimum 8 AWG bare solid copper conductor, including the 8 AWG copper equipotential bonding conductor if available.

(b) The conductors follow the contour of the perimeter surface.

- (c) The conductor(s) is 450 mm to 600 mm (18 in. to 24 in.) from the inside walls of the pool.
- (d) The conductor(s) is under the unpaved portion of the perimeter surface 100 mm to 150 mm (4 in. to 6 in.) below finished grade.
- (e) Be installed only in perimeter surfaces not intended to have direct access to swimmers in the pool.

(2) Copper conductor grid or unencapsulated structural steel welded wire reinforcement used for equipotential bonding of unpaved portions of perimeter surfaces shall meet the following:

- (a) Be installed in accordance with 680.26(B)(2)(a).
- (b) Be located within unpaved surface(s) between 100 mm to 150 mm (4 in. to 6 in.) below finished grade.
- (c) Nonconductive Perimeter Surfaces. Equipotential bonding shall not be required for nonconductive portions of perimeter surfaces that are separated from earth or raised on nonconducting supports.
Equipotential bonding shall not be required for any perimeter surface that is electrically separated from the pool structure and raised on nonconductive supports above an equipotentially bonded surface.

Informational Note: Nonconductive materials include, but are not limited to, wood, plastic, wood-plastic composites, fiberglass, and fiberglass composites.

- (d) Interconnection of Bonded Portions of Perimeter Surfaces. The solid copper, not smaller than 8 AWG conductor shall be permitted to encircle the pool to facilitate bonding connections to portions of the perimeter covered in 680.26(B)(2)(a) and (B)(2)(b) that are not contiguous





Public Input No. 1916-NFPA 70-2023 [Section No. 680.26(B)(2)]

(2) Perimeter Surfaces.

The perimeter surface to be bonded shall be considered to extend for 900 mm (3 ft) horizontally beyond the inside walls of the pool while also at a height between 900 mm (3 ft) above and 600 mm (2 ft) below the maximum water level. The perimeter surface shall include unpaved surfaces, concrete, and other types of paving. Perimeter surfaces separated from the pool by a permanent wall or building 1.5 m (5 ft) in height or more shall require equipotential bonding only on the pool side of the permanent wall or building. Bonding to perimeter surfaces shall be provided as specified in 680.26(B)(2)(a), (B)(2)(b), (B)(2)(c), and (B)(2)(d). For conductive pool shells where bonding to perimeter surfaces is required, it shall be attached to the pool reinforcing steel or copper conductor grid at a minimum of four points uniformly spaced around the perimeter of the pool, or if the bonded perimeter surface does not surround the entire pool, it shall be attached to the pool reinforcing steel or copper conductor grid at a minimum of four uniformly spaced points along the bonded perimeter surface. For nonconductive pool shells, where bonding to the perimeter surfaces is required, bonding at four points shall not be required, and the perimeter bonding shall be attached to the 8 AWG copper equipotential bonding conductor and, if present, to any conductive support structure for the pool.

Informational Note: Because the perimeter surface can incorporate various types of materials at various locations and elevations above and below maximum water level, the perimeter surface required to be bonded might not surround the entire pool. The 8 AWG copper equipotential bonding conductor can encircle the entire pool to facilitate connection of bonded parts.

(a) *Conductive Paved Portions of Perimeter Surfaces.* Conductive paved portions of perimeter surfaces, including masonry pavers, if used, shall be bonded with unencapsulated structural reinforcing steel in accordance with 680.26(B)(1)(a), or with unencapsulated steel structural welded wire reinforcement (welded wire mesh, welded wire fabric), bonded together by steel tie wires or the equivalent. Steel welded wire reinforcement shall be fully embedded within the pavement unless the pavement will not allow for embedding. If the reinforcing steel is absent, or is encapsulated in a nonconductive compound, or embedding is not possible, unencapsulated welded wire steel reinforcement or a copper conductor grid shall be provided and shall be secured directly under the paving, and not more than 150 mm (6 in.) below finished grade.

Unencapsulated steel welded wire reinforcement that is not fully embedded in concrete ; ~~and copper grid regardless of location,~~ where used for equipotential bonding, shall be listed for corrosion resistance and mechanical performance. This listing requirement shall become effective January 1, 2025. The copper grid or unencapsulated steel welded wire reinforcement shall also meet the following:

- (1) Copper grid is constructed of 8 AWG solid bare copper and arranged in accordance with 680.26(B)(1)(b)(3).
- (2) Steel welded wire reinforcement is minimum ASTM 6 × 6-W2.0 × W2.0 or minimum No. 3 rebar constructed in a 300 mm (12 in.) grid.
- (3) Copper grid and steel welded wire reinforcement follow the contour of the perimeter surface extending not less than 900 mm (3 ft) horizontally beyond the inside walls of the pool.
- (4) Only listed splicing devices or exothermic welding are used.

Informational Note No. 1: Performance of the equipotential bonding system at the perimeter surface is improved as the distance between the bonding means and finished grade is minimized, either by embedding within, or by direct contact with the underside of, the finished pavement.

Informational Note No. 2: See ASTM A615/A615M, *Standard Specification for Deformed and Plain Carbon-Steel Bars for Concrete Reinforcement*; A1064/A1064M, *Standard Specification for Carbon-Steel Wire and Welded Wire Reinforcement, Plain and Deformed, for Concrete*; A1022/A1022M, *Standard Specification for Deformed and Plain Stainless Steel Wire and Welded Wire for Concrete Reinforcement*; A1060A/A1060M, *Standard Specification for Zinc-Coated (Galvanized) Steel Welded Wire Reinforcement, Plain and Deformed, for Concrete*; and ACI Standard ACI 318, *Building Code Requirements for Structural Concrete*, for examples of standards currently used in the listing of reinforcing steel bars and steel welded wire reinforcement.

(b) *Unpaved Portions of Perimeter Surfaces.* Unpaved portions of perimeter surfaces shall be bonded with any of the following methods:

- (3) Copper conductor(s) shall meet the following:
- (4) At least one minimum 8 AWG bare solid copper conductor, including the 8 AWG copper equipotential bonding conductor if available.
 - (5) The conductors follow the contour of the perimeter surface.
 - (6) Only listed splicing devices or exothermic welding are used.
 - (7) The conductor(s) is 450 mm to 600 mm (18 in. to 24 in.) from the inside walls of the pool.
 - (8) The conductor(s) is under the unpaved portion of the perimeter surface 100 mm to 150 mm (4 in. to 6 in.) below finished grade.
 - (9) Be installed only in perimeter surfaces not intended to have direct access to swimmers in the pool.
- (10) Copper grid or unencapsulated steel welded wire reinforcement used for equipotential bonding of unpaved portions of perimeter surfaces shall meet the following:
- (11) Be installed in accordance with 680.26(B)(2)(a) .
 - (12) Be located within unpaved surface(s) between 100 mm to 150 mm (4 in. to 6 in.) below finished grade.

(m) *Nonconductive Perimeter Surfaces.* Equipotential bonding shall not be required for nonconductive portions of perimeter surfaces that are separated from earth or raised on nonconducting supports, and it shall not be required for any perimeter surface that is electrically separated from the pool structure and raised on nonconductive supports above an equipotentially bonded surface.

Informational Note: Nonconductive materials include, but are not limited to, wood, plastic, wood-plastic composites, fiberglass, and fiberglass composites.

(n) *Interconnection of Bonded Portions of Perimeter Surfaces.* All surfaces where equipotential bonding is required shall be interconnected using listed splicing devices or exothermic welding. Where copper wire is used for this purpose, it shall be solid copper, not smaller than 8 AWG. The conductor shall be permitted to encircle the pool to facilitate bonding connections to portions of the perimeter covered in 680.26(B)(2)(a) and (B)(2)(b) that are not contiguous.

Statement of Problem and Substantiation for Public Input

The deleted language, "and copper grid regardless of location", acts to prohibit the field construction of a copper bonding grid as a field constructed grid would not be a listed product. 680.26(B)(2)(a)(1) references 680.26(B)(1)(b) that permits the field construction of the grid. The pool shell copper grid in 680.26(B)(1)(b) does not contain this listing requirement.

Note, even though terraview shows otherwise, the only change made by this PI is to the language in the second paragraph of the parent text of 680.28(B)(2)(a),

Submitter Information Verification

Submitter Full Name: Don Ganiere

Organization: none

Street Address:**City:****State:****Zip:****Submittal Date:** Mon Aug 07 15:16:46 EDT 2023**Committee:** NEC-P17**Committee Statement****Resolution:** [FR-9239-NFPA 70-2024](#)**Statement:** Revisions to this section include:

Informational Note 1 to 680.26(A) was revised to comply with 2.1.10 of the NEC Style Manual.

Informational Note 2 to 680.26(A) was deleted as it did not add clarity to the requirements. Corrosive environments are already addressed in 680.14, and performance requirements are already addressed in 680.26(A). Therefore, this language is not needed.

Section 680.26(B) was editorially revised into a list format for ease of reading, in accordance with 3.5.2 of the NEC Style Manual. New text was added to clarify that structural reinforcing steel and steel structural welded wire reinforcement are permitted options for bonding. These options were inferred but not explicitly stated.

Section 680.26(B) was revised by changing “panelboard” to “panelboard enclosure” for accuracy.

Multiple editorial changes were made to 680.26(B)(2) for clarification and readability; and redundant language, including 680.26(B)(2)(d), was eliminated. The word “conductor” was added to the phrase “copper grid” in multiple locations for consistency, as was adding the word “structural” to the phrase “reinforcing steel.”

An allowance for a copper conductor grid was added in 680.26(B)(2)(a)(2) because a copper conductor grid should be a permitted method of achieving the bonding contemplated in this section.



Public Input No. 2020-NFPA 70-2023 [Section No. 680.26(B)(2)]

(2) Perimeter Surfaces.

The perimeter surface to be bonded shall be considered to extend for 900 mm (3 ft) horizontally beyond the inside walls of the pool while also at a height between 900 mm (3 ft) above and 600 mm (2 ft) below the maximum water level. The perimeter surface shall include unpaved surfaces, concrete, and other types of paving. Perimeter surfaces separated from the pool by a permanent wall or building 1.5 m (5 ft) in height or more shall require equipotential bonding only on the pool side of the permanent wall or building. Bonding to perimeter surfaces shall be provided as specified in 680.26(B)(2)(a), (B)(2)(b), (B)(2)(c), and (B)(2)(d). For conductive pool shells where bonding to perimeter surfaces is required, it shall be attached to the pool reinforcing steel or copper conductor grid at a minimum of four points uniformly spaced around the perimeter of the pool, or if the bonded perimeter surface does not surround the entire pool, it shall be attached to the pool reinforcing steel or copper or 40% copper-clad steel conductor grid at a minimum of four uniformly spaced points along the bonded perimeter surface. For nonconductive pool shells, where bonding to the perimeter surfaces is required, bonding at four points shall not be required, and the perimeter bonding shall be attached to the 8 AWG copper or 40% copper-clad steel equipotential bonding conductor and, if present, to any conductive support structure for the pool.

Informational Note: Because the perimeter surface can incorporate various types of materials at various locations and elevations above and below maximum water level, the perimeter surface required to be bonded might not surround the entire pool. The 8 AWG copper or 40% copper-clad steel equipotential bonding conductor can encircle the entire pool to facilitate connection of bonded parts.

(a) *Conductive Paved Portions of Perimeter Surfaces.* Conductive paved portions of perimeter surfaces, including masonry pavers, if used, shall be bonded with unencapsulated structural reinforcing steel in accordance with 680.26(B)(1)(a), or with unencapsulated steel structural welded wire reinforcement (welded wire mesh, welded wire fabric), bonded together by steel tie wires or the equivalent. Steel welded wire reinforcement shall be fully embedded within the pavement unless the pavement will not allow for embedding. If the reinforcing steel is absent, or is encapsulated in a nonconductive compound, or embedding is not possible, unencapsulated welded wire steel reinforcement or a copper or 40% copper-clad steel conductor grid shall be provided and shall be secured directly under the paving, and not more than 150 mm (6 in.) below finished grade.

Unencapsulated steel welded wire reinforcement that is not fully embedded in concrete, and copper or 40% copper-clad steel grid regardless of location, where used for equipotential bonding, shall be listed for corrosion resistance and mechanical performance. This listing requirement shall become effective January 1, 2025. The copper or 40% copper-clad steel grid or unencapsulated steel welded wire reinforcement shall also meet the following:

- (1) ~~Copper- The~~ grid is constructed of 8 AWG solid bare copper or 40% copper-clad steel and arranged in accordance with 680.26(B)(1)(b)(3).
- (2) Steel welded wire reinforcement is minimum ASTM 6 × 6-W2.0 × W2.0 or minimum No. 3 rebar constructed in a 300 mm (12 in.) grid.
- (3) ~~Copper- The~~ grid and steel welded wire reinforcement follow the contour of the perimeter surface extending not less than 900 mm (3 ft) horizontally beyond the inside walls of the pool.
- (4) Only listed splicing devices or exothermic welding are used.

Informational Note No. 1: Performance of the equipotential bonding system at the perimeter surface is improved as the distance between the bonding means and finished grade is minimized, either by embedding within, or by direct contact with the underside of, the finished pavement.

Informational Note No. 2: See ASTM A615/A615M, *Standard Specification for Deformed and Plain Carbon-Steel Bars for Concrete Reinforcement*; A1064/A1064M, *Standard Specification for Carbon-Steel Wire and Welded Wire Reinforcement, Plain and Deformed, for Concrete*; A1022/A1022M, *Standard Specification for Deformed and Plain Stainless Steel Wire and Welded Wire for Concrete Reinforcement*; A1060A/A1060M, *Standard Specification for Zinc-Coated (Galvanized) Steel Welded Wire Reinforcement, Plain and Deformed, for Concrete*; and ACI Standard ACI 318, *Building Code Requirements for Structural Concrete*, for examples of standards currently used in the listing of reinforcing steel bars and steel welded wire reinforcement.

(b) *Unpaved Portions of Perimeter Surfaces.* Unpaved portions of perimeter surfaces shall be bonded with any of the following methods:

- (3) Copper conductor(s) shall meet the following:
 (4) At least one minimum 8 AWG bare solid copper

conductor

- (1)
- a. or 40% copper-clad steel conductor , including the 8 AWG copper or 40% copper-clad steel equipotential bonding conductor if available.
 - b. The conductors follow the contour of the perimeter surface.
 - c. Only listed splicing devices or exothermic welding are used.
 - d. The conductor(s) is 450 mm to 600 mm (18 in. to 24 in.) from the inside walls of the pool.
 - e. The conductor(s) is under the unpaved portion of the perimeter surface 100 mm to 150 mm (4 in. to 6 in.) below finished grade.
 - f. Be installed only in perimeter surfaces not intended to have direct access to swimmers in the pool.

Copper

- (1) The grid or unencapsulated steel welded wire reinforcement used for equipotential bonding of unpaved portions of perimeter surfaces shall meet the following:
- (5) Be installed in accordance with 680.26(B)(2)(a) .
 - (6) Be located within unpaved surface(s) between 100 mm to 150 mm (4 in. to 6 in.) below finished grade.

(g) *Nonconductive Perimeter Surfaces.* Equipotential bonding shall not be required for nonconductive portions of perimeter surfaces that are separated from earth or raised on nonconducting supports, and it shall not be required for any perimeter surface that is electrically separated from the pool structure and raised on nonconductive supports above an equipotentially bonded surface.

Informational Note: Nonconductive materials include, but are not limited to, wood, plastic, wood-plastic composites, fiberglass, and fiberglass composites.

(h) *Interconnection of Bonded Portions of Perimeter Surfaces.* All surfaces where equipotential bonding is required shall be interconnected using listed splicing devices or exothermic welding. Where copper or 40% copper-clad steel wire is used for this purpose, it shall be solid-copper , not smaller than 8 AWG. The conductor shall be permitted to encircle the pool to facilitate bonding connections to portions of the perimeter covered in 680.26(B)(2)(a) and (B)(2)(b) that are not contiguous.

Statement of Problem and Substantiation for Public Input

See Substantiation for PI 1102.

Submitter Information Verification

Submitter Full Name: Peter Graser

Organization: Copperweld
Affiliation: American Bimetallic Association
Street Address:
City:
State:
Zip:
Submittal Date: Fri Aug 11 08:07:18 EDT 2023
Committee: NEC-P17

Committee Statement

Resolution: CMP17 has concerns including corrosion at the ends of copper-clad steel conductors and copper-clad reinforcing steel installed in concrete, earth, or other corrosive environments. CMP17 also requests data showing how the product reacts to exothermic welding, as that process is a permitted method of connection in this section.



Public Input No. 213-NFPA 70-2023 [Section No. 680.26(B)(2)]

Replace all text in 680.26 (2)– B)(2) with the following replacement text (copied from the TIA submission except the effective date for listing was changed to reflect inclusion in the 2026 Edition rather than the 2023 Edition):

~~(2) **Perimeter Surfaces** . The perimeter surface to be bonded shall be considered to extend for~~

~~1 m~~

~~900 mm (~~

~~3 ft~~

3 ft) horizontally beyond the inside walls of the pool, while also at a height between 900 mm (3 ft) above and 600 mm (2 ft) below the maximum water level. The perimeter surface shall include unpaved surfaces, concrete, and other types of paving. Perimeter surfaces separated from the pool by a permanent wall or building 1.

~~5 m~~

~~5 m (~~

~~5 ft~~

5 ft) in height or more shall require equipotential bonding only on the pool side of the permanent wall or building. Bonding to perimeter surfaces shall be provided as specified in 680.26(B)(2)(a), (B)(2)(b),

~~or~~

(B)(2)(c), and (B)(2)(d). For conductive pool shells where bonding to perimeter surfaces is required, it shall be attached to the pool reinforcing steel or copper conductor grid at a minimum of four points uniformly spaced around the perimeter of the pool, or if the bonded perimeter surface does not surround the entire pool, it shall be attached to the pool reinforcing steel or copper conductor grid at a minimum of four uniformly spaced points along the bonded perimeter surface. For nonconductive pool shells, where bonding to the perimeter surfaces is required, bonding at four points shall not be required

~~: **Structural Reinforcing Steel:** Structural reinforcing steel shall be bonded~~

~~, and the perimeter bonding shall be attached to the 8 AWG copper equipotential bonding conductor and, if present, to any conductive support structure for the pool.~~

Informational Note: Because the perimeter surface can incorporate various types of materials at various locations and elevations above and below maximum water level, the perimeter surface required to be bonded might not surround the entire pool. The 8 AWG copper equipotential bonding conductor can encircle the entire pool to facilitate connection of bonded parts.

(a) **Conductive Paved Portions of Perimeter Surfaces** . Conductive paved portions of perimeter surfaces, including masonry pavers, if used, shall be bonded with unencapsulated structural reinforcing steel in accordance with 680.26(B)(1)(a)

~~: **Copper Ring:** Where structural reinforcing steel is not available~~

~~, or with unencapsulated steel structural welded wire reinforcement (welded wire mesh, welded wire fabric), bonded together by steel tie wires or the equivalent. Steel welded wire reinforcement shall be fully embedded within the pavement unless the pavement will not allow for embedding. If the reinforcing steel is absent, or is encapsulated in a nonconductive compound, or embedding is not possible, unencapsulated welded wire steel reinforcement or a copper conductor~~

~~(s) shall be utilized where the following requirements are met:~~

- ~~• At least one minimum 8 AWG bare solid copper conductor shall be provided.~~

~~The conductors shall~~

~~grid shall be provided and shall be secured directly under the paving, and not more than 150 mm (6 in.) below finished grade. Unencapsulated steel welded wire reinforcement that is not~~

fully embedded in concrete, and copper grid regardless of location, where used for equipotential bonding, shall be listed for corrosion resistance and mechanical performance. This listing requirement shall become effective January 1, 2027. The copper grid or unencapsulated steel welded wire reinforcement shall also meet the following:

(1) Copper grid is constructed of 8 AWG solid bare copper and arranged in accordance with 680.26(B)(1)(b)(3).

(2) Steel welded wire reinforcement is minimum ASTM 6x6-W2.0 x W2.0 or minimum No. 3 rebar constructed in a 300 mm (12 in.) grid.

(3) Copper grid and steel welded wire reinforcement follow the contour of the perimeter surface extending not less than 900 mm (3 ft) horizontally beyond the inside walls of the pool.

(4) Only listed splicing devices or exothermic welding are used.

Informational Note No. 1: Performance of the equipotential bonding system at the perimeter surface is improved as the distance between the bonding means and finished grade is minimized, either by embedding within, or by direct contact with the underside of, the finished pavement.

Informational Note No. 2: See ASTM A615/A615M, *Standard Specification for Deformed and Plain Carbon-Steel Bars for Concrete Reinforcement*; A1064/A1064M *Standard Specification for Carbon-Steel Wire and Welded Wire Reinforcement, Plain and Deformed, for Concrete*; A1022/A1022M *Standard Specification for Deformed and Plain Stainless Steel Wire and Welded Wire for Concrete Reinforcement*; A1060A/A1060M, *Standard*

Specification for Zinc-Coated (Galvanized) Steel Welded Wire Reinforcement, Plain and Deformed, for Concrete; and ACI Standard ACI 318, *Building Code Requirements for Structural Concrete*, for examples of standards currently used in the listing of reinforcing steel bars and steel welded wire reinforcement.

(b) *Unpaved Portions of Perimeter Surfaces*. Unpaved portions of perimeter surfaces shall be bonded with any of the following methods:

(1) Copper conductor(s) shall meet the following:

a. At least one minimum 8 AWG bare solid copper conductor, including the 8 AWG copper equipotential bonding conductor if available.

b. The conductors follow the contour of the perimeter surface.

c. Only listed splicing devices or exothermic welding

shall be permitted

are used.

d. The

required conductor shall be 450 mm to 600 mm (18 in. to 24 in

conductor(s) is 450 mm to 600 mm (18 in. to 24 in.) from the inside walls of the pool.

e. The

required conductor shall be secured within or under the

conductor(s) is under the unpaved portion of the perimeter surface 100 mm to 150 mm (4 in. to 6 in.) below the

subgrade

finished grade .

Copper Grid . Where structural reinforcing steel is not available or is encapsulated in a nonconductive compound, copper grid shall be utilized where the following requirements are met: The copper grid shall be constructed of 8 AWG solid bare copper and be arranged

f. Be installed only in perimeter surfaces not intended to have direct access to swimmers in the pool.

(2) Copper grid or unencapsulated steel welded wire reinforcement used for equipotential bonding of unpaved portions of perimeter surfaces shall meet the following:

a. Be installed in accordance with 680.26(B)(

4

2)(a).

b . Be located within the unpaved surface(s)

(3):

- The copper grid shall follow the contour of the perimeter surface extending 1 m (3 ft) horizontally beyond the inside walls of the pool.

Only

between 100 mm to 150 mm (4 in. to 6 in.) below the finished grade.

(c) Nonconductive Perimeter Surfaces . Equipotential bonding shall not be required for nonconductive portions of perimeter surfaces that are separated from earth or raised on nonconducting supports, and it shall not be required for any perimeter surface that is electrically separated from the pool structure and raised on nonconductive supports above an equipotentially bonded surface.

Informational Note: Nonconductive materials include, but are not limited to, wood, plastic, wood-plastic composites, fiberglass, and fiberglass composites.

(d) Interconnection of Bonded Portions of Perimeter Surfaces . All surfaces where equipotential bonding is required shall be interconnected using listed splicing devices or exothermic welding

shall be permitted. The copper grid shall be secured within or under the deck or unpaved surfaces between 100 mm to 150 mm (4 in. to 6 in.) below the subgrade

. Where copper wire is used for this purpose, it shall be solid copper, not smaller than 8 AWG. The conductor shall be permitted to encircle the pool to facilitate bonding connections to portions of the perimeter covered in 680.26(B)(2)(a) and (B)(2)(b) that are not contiguous .

Statement of Problem and Substantiation for Public Input

This change in NEC 680.26(B)(2) was approved by the Task Group addressing TIA 1867 for the 2023 Edition, and is submitted for consideration by CMP-17 as a companion to the Task Group recommendations for changes to NEC100 (definition of "Pool") and NEC 680.26(A), in the event the TIA is not adopted.

The Task Group's substantiation for the change herein is as follows (including the introductory material) and is submitted as substantiation for this change:

"This Tentative Interim Amendment (TIA) is proposed by a Task Group appointed by NFPA staff pursuant to the decision of the Standards Council D#22-3 on Agenda item SC#22-8-5-w-1 as voted 12 August 2022. This decision denied the underlying appeal, but found that issues raised at the hearing relative to current research and loss experience required "timely analysis." Given the "highly technical nature" of the subject matter, the Council directed that this Task Group be one that was "balanced" and

that possessed the technical expertise to evaluate the relevant research. As there is considerable controversy over this issue, the focus was reaching common ground which would result in a practical compromise acceptable to the participants.

"The Task Group focused its attention on 680.26(B)(2) which covers the bonding of the surfaces that make up the perimeter of a swimming pool. After extensive discussion, the Task Group is proposing a complete rewrite of this material, as well as related material within the scope of CMP 17. The detailed substantiation follows:

[Regarding changes to 680.26(B)(2)] "The remainder of the TIA addresses 680.26(B)(2) on "Perimeter Surfaces." This location was the focus of the Standards Council appeal, and it involved the most extensive discussions. The mandatory horizontal reach of these requirements, 900mm (3 ft), is unchanged. The task group discussed at length increasing this distance to 5 ft , and decided against changing the mandatory limit; however, the task group did agree to change the wording to "not less than" to emphasize that the distance specified is not an upper limit, only the lower limit. It is important to recognize that any horizontal measurement extends an island of stable voltage in a potential sea of gradients. Addressing these could logically require extending the size of the island to encompass the entire parcel of land, and that clearly would be impractical. The 3-ft parameter addresses the enhanced exposure presented to swimmers entering or exiting a pool or to persons simultaneously in contact with the perimeter surface and the pool water.

"There is also a height parameter added that limits the reach to surfaces within 900mm (3 ft) above the maximum water level and not over 600 mm (2 ft) below this level. The vertical limit excludes surfaces that are out of reach of a swimmer (3 ft vertical reach from within the pool, or what would end up being a reach across a pool wall and then 2 ft down to grade) and also excludes aboveground pools that do not present a walk-off exposure. These were also excluded in the public comment that put the appeal in motion. The 2 ft measurement also prevents someone from making the distinction with a pool that is really an inground pool with a minor upward extension from grade.

"Nonconductive pool shells continue to omit the four-corner bonding connection rule as such connections are impossible. However, there will be other more enhanced requirements in place. Any perimeter surfaces that are included elsewhere in a bonding requirement must meet that requirement, with the bonding to include a connection to an 8 AWG solid conductor that will also make a connection to the water and any other bonded surfaces. It will also be connected to any conductive support structure for the pool. The surrounding perimeter surfaces incorporate a bonding requirement, and the wording here assures that such bonding includes other relevant parts of the pool and the immediately surrounding perimeter locations.

"A new informational note follows at this point that describes the principal remaining utility of the single wire bonding connection, and that is to interconnect noncontiguous portions of a pool that has stranded perimeter surfaces with intervening spaces that do not present an exposure hazard from voltage gradients. A good example would be a pool with one wall that is on the edge of a steep incline, one that precludes any entrance or exit from the pool from that side. The remainder of the section is completely rewritten with four third level subdivisions [(a), (b), (c), and (d)]. The first [(a)] one covers conductive paved portions of perimeter surfaces. The word "conductive" in this case correlates with the use of equivalent terminology in 680.26(B)(1), and thereby includes cast-in-place concrete, pneumatically applied or sprayed concrete, and concrete block with painted or plastered coatings, and it recognizes the increased conductivity resulting the proximity of water and the resulting permeability and porosity. The topic sentence also expressly includes masonry pavers in this category.

"The language includes prescriptive requirements on the reinforcing used in these surfaces, which where used must comply with equivalent reinforcing applications for the pool itself in 680.26(B)(1)(a), or apply welded wire mesh. The mesh must be chaired up so as to be completely embedded within the concrete placement. The text does allow for the use of fiber reinforcement which precludes embedded conductive reinforcement. In such cases the grid must be positioned below the concrete, but no more than 6 in. below finished grade. The "finished grade" parameter was supposed to have been included in the 2023 NEC, but its inclusion was a casualty of the Standards Council action to revert to previous edition text; it is now being restored. A new informational note follows, explaining the effects of locating the bonding elements as close to the surface as possible.

"Also included are requirements for grids for equipotential bonding. Steel and copper show up together, now with the same requirements, and the grade reference is corrected from the former "subgrade" to the intended "finished grade" The equivalence between steel and copper is intended, because a new requirement is added for a listing on this equipment with an appropriate delayed effective date [adjusted in this PI to reflect that this PI addresses the 2026 Edition and not the 2023 Edition]. The listing requirement would not apply to fully embedded steel reinforcing because it is already subject to testing and identification under applicable standards which address corrosion and mechanical performance, including for full embedding in concrete, and because years of experience has shown that where fully embedded, traditional reinforcing members which meet the applicable standards retain their integrity. A new informational note here provides comprehensive background information on ASTM recognized classifications for reinforcing steel as could be applied (contingent on a listing) in these applications.

"The next third level subdivision [(b)] covers unpaved perimeter surfaces, leading off, in (1), with the single bare 8 AWG conductor. The first five list items are unchanged from the 2023 NEC, and are not in themselves controversial. Regarding the sixth list item, the Task Group did not reach any specific conclusion as to the comparative effectiveness of various bonding approaches. As a compromise, the single wire is now to be allowed only under perimeter surfaces that do not have "direct access to swimmers in the pool." Any other perimeter surface required to be bonded must now employ a grid bonding approach. Note that this phrasing carefully avoided the use of related terms including "accessible" as covered in Art. 100; this usage generally correlates with the limitations of these requirements to areas involved in the exposure of swimmers to voltage gradients.

"The other major topic here, in (2), covers the use of grids for equipotential bonding. Steel and copper show up together, now with the same requirements as for paved surfaces, and here again, the grade reference is corrected from the former "subgrade" to the intended "finished grade" The next third level subdivision [(c)] covers a common-sense exemption from bonding to surfaces that are nonconductive, and as such are inherently excluded from the potential propagation of voltage gradients. This includes any perimeter surfaces that are electrically separated from the pool structure and raised on nonconductive supports above a bonded surface. For example, this latter type of construction is sometimes used for (but not limited to) pools on and in buildings where the surrounding floor is inherently and securely bonded due to the concrete reinforcement, but there is a walking surface consisting of individual tiles or nonconductive boards, separated from each other and from the pool structure, and raised above the bonded floor on insulated risers. Such an arrangement isolates the user of the perimeter surface from whatever might exist in terms of voltage gradients.

"The final third level subdivision [(d)] requires the interconnection of all bonded portions of perimeter surfaces. If this were not so, the voltage on one part of the perimeter could differ from another part. This in turn could allow a dangerous potential difference to exist between adjacent parts of the perimeter, and thereby undermine the objectives of the other rules.

Related Public Inputs for This Document

<u>Related Input</u>	<u>Relationship</u>
Public Input No. 211-NFPA 70-2023 [Definition: Pool.]	Companion submittal originally incorporated as part of TIA.
Public Input No. 212-NFPA 70-2023 [Section No. 680.26(A)]	Companion submittal originally incorporated as part of TIA.
Public Input No. 211-NFPA 70-2023 [Definition: Pool.]	
Public Input No. 212-NFPA 70-2023 [Section No. 680.26(A)]	

Submitter Information Verification

Submitter Full Name: E. P. Hamilton

Organization: E. P. Hamilton & Associates, Inc.

Street Address:

City:

State:

Zip:

Submittal Date: Sat Jan 21 18:15:16 EST 2023

Committee: NEC-P17

Committee Statement

Resolution: [FR-9239-NFPA 70-2024](#)

Statement: Revisions to this section include:

Informational Note 1 to 680.26(A) was revised to comply with 2.1.10 of the NEC Style Manual.

Informational Note 2 to 680.26(A) was deleted as it did not add clarity to the requirements. Corrosive environments are already addressed in 680.14, and performance requirements are already addressed in 680.26(A). Therefore, this language is not needed.

Section 680.26(B) was editorially revised into a list format for ease of reading, in accordance with 3.5.2 of the NEC Style Manual. New text was added to clarify that structural reinforcing steel and steel structural welded wire reinforcement are permitted options for bonding. These options were inferred but not explicitly stated.

Section 680.26(B) was revised by changing “panelboard” to “panelboard enclosure” for accuracy.

Multiple editorial changes were made to 680.26(B)(2) for clarification and readability; and redundant language, including 680.26(B)(2)(d), was eliminated. The word “conductor” was added to the phrase “copper grid” in multiple locations for consistency, as was adding the word “structural” to the phrase “reinforcing steel.”

An allowance for a copper conductor grid was added in 680.26(B)(2)(a)(2) because a copper conductor grid should be a permitted method of achieving the bonding contemplated in this section.



Public Input No. 278-NFPA 70-2023 [Section No. 680.26(B)(2)]

(2) Perimeter Surfaces.

The perimeter surface to be bonded shall be considered to extend for 1 m (3 ft) horizontally beyond the inside walls of the pool and shall include unpaved surfaces and other types of paving. Perimeter surfaces separated from the pool by a permanent wall or building 1.5 m (5 ft) in height or more shall require equipotential bonding only on the pool side of the permanent wall or building. Bonding to perimeter surfaces shall be provided as specified in 680.26(B)(2)(a), (B)(2)(b), or (B)(2)(c) and shall be attached to the pool reinforcing steel or copper conductor grid at a minimum of four points uniformly spaced around the perimeter of the pool. For nonconductive pool shells, bonding at four points shall not be required.

(a) *Structural Reinforcing Steel.* Structural reinforcing steel shall be bonded in accordance with 680.26(B)(1)(a).

(b) *Copper Ring.* Where structural reinforcing steel is not available or is encapsulated in a nonconductive compound, a copper conductor(s) shall be utilized where the following requirements are met:

- (3) At least one minimum 8 AWG bare solid copper conductor shall be provided.
- (4) The conductors shall follow the contour of the perimeter surface.
- (5) Only listed splicing devices or exothermic welding shall be permitted.
- (6) The required conductor shall be 450 mm to 600 mm (18 in. to 24 in.) from the inside walls of the pool.
- (7) The required conductor shall be secured within or under the perimeter surface 100 mm to 150 mm (4 in. to 6 in.) below the subgrade.

(h) *Copper Grid.* Where structural reinforcing steel is not available or is encapsulated in a nonconductive compound, copper grid shall be utilized where the following requirements are met:

- (9) The copper grid shall be constructed of 8 AWG solid bare copper and be arranged in accordance with 680.26(B)(1)(b)(3).
- (10) The copper grid shall follow the contour of the perimeter surface extending 1 m (3 ft) horizontally beyond the inside walls of the pool.
- (11) Only listed splicing devices or exothermic welding shall be permitted.
- (12) The copper grid shall be secured within or under the deck or unpaved surfaces between 100 mm to 150 mm (4 in. to 6 in.) below the subgrade.

Exception: Perimeter surface bonding shall not be required where perimeter surfaces are constructed of nonconductive materials such as wood, plastic, or fiberglass unless the nonconductive perimeter surface is elevated to provide personnel access underneath the elevated portion where personnel would be in contact with the earth or other conductive surfaces while walking, crawling or otherwise traversing that area.

Additional Proposed Changes

File Name

Description

Approved

680.26_excption_1.pdf

Perimeter surface bonding under nonconductive construction

Statement of Problem and Substantiation for Public Input

This exception is needed to provide relief from bonding perimeter areas underneath nonconductive decking material. The nonconductive construction would essentially eliminate any step potential making the bonding grid or bonding ring around the pool superfluous. Where decking is raised high enough to allow people to crawl or walk on earth or other conductive surfaces where step potential or touch could still present a hazard, then perimeter bonding should still apply. This exception addresses those issues. See attached PDF for examples.

Related Public Inputs for This Document

<u>Related Input</u>	<u>Relationship</u>
Public Input No. 279-NFPA 70-2023 [Section No. 680.26(B)(2)]	

Submitter Information Verification

Submitter Full Name: Russ Leblanc
Organization: Leblanc Consulting Services
Street Address:
City:
State:
Zip:
Submittal Date: Fri Feb 03 12:51:43 EST 2023
Committee: NEC-P17

Committee Statement

Resolution: The proposed revisions from this public input were based on 2023 NEC 680.26 text existing prior to the issuance of TIA 23-9. The objectives of the submitter were accomplished by TIA 23-9. Therefore, no revisions were made.

*680.26 Exception:
Perimeter bonding shall not
be required where perimeter
surfaces are constructed of
nonconductive materials
such as wood, plastic, or
fiberglass unless the
nonconductive perimeter
surface...(continued)*



Nonconductive
decking



...unless the nonconductive perimeter surface is elevated to provide personnel access underneath the elevated portion where personnel would be in contact with the earth or other conductive surfaces while walking, crawling or otherwise traversing that area."

Perimeter bonding applies underneath raised nonconductive decking with personnel access



Public Input No. 279-NFPA 70-2023 [Section No. 680.26(B)(2)]

(2) Perimeter Surfaces.

The perimeter surface to be bonded shall be considered to extend for 1 m (3 ft) horizontally beyond the inside walls of the pool and shall include unpaved surfaces and other types of paving. Perimeter surfaces separated from the pool by a permanent wall or building 1.5 m (5 ft) in height or more shall require equipotential bonding only on the pool side of the permanent wall or building. Bonding to perimeter surfaces shall be provided as specified in 680.26(B)(2)(a), (B)(2)(b), or (B)(2)(c) and shall be attached to the pool reinforcing steel or copper conductor grid at a minimum of four points uniformly spaced around the perimeter of the pool. For nonconductive pool shells, bonding at four points shall not be required.

(a) *Structural Reinforcing Steel.* Structural reinforcing steel shall be bonded in accordance with 680.26(B)(1)(a).

(b) *Copper Ring.* Where structural reinforcing steel is not available or is encapsulated in a nonconductive compound, a copper conductor(s) shall be utilized where the following requirements are met:

- (3) At least one minimum 8 AWG bare solid copper conductor shall be provided.
- (4) The conductors shall follow the contour of the perimeter surface.
- (5) Only listed splicing devices or exothermic welding shall be permitted.
- (6) The required conductor shall be 450 mm to 600 mm (18 in. to 24 in.) from the inside walls of the pool.
- (7) The required conductor shall be secured within or under the perimeter surface 100 mm to 150 mm (4 in. to 6 in.) below the subgrade.

(h) *Copper Grid.* Where structural reinforcing steel is not available or is encapsulated in a nonconductive compound, copper grid shall be utilized where the following requirements are met:

- (9) The copper grid shall be constructed of 8 AWG solid bare copper and be arranged in accordance with 680.26(B)(1)(b)(3).
- (10) The copper grid shall follow the contour of the perimeter surface extending 1 m (3 ft) horizontally beyond the inside walls of the pool.
- (11) Only listed splicing devices or exothermic welding shall be permitted.
- (12) The copper grid shall be secured within or under the deck or unpaved surfaces between 100 mm to 150 mm (4 in. to 6 in.) below the subgrade.

Exception: Perimeter bonding shall not be required for perimeter surface areas with no access for personnel to walk, crawl, or otherwise traverse that area.

Informational note: Infinity pools are an example where the infinity edge of the pool may not have any access for personnel to traverse the area outside of that edge.

Additional Proposed Changes

File Name

Description

Approved

680.26_exception_2.pdf Perimeter bonding exception

Statement of Problem and Substantiation for Public Input

This exception is needed to provide relief from bonding perimeter surfaces where people will not be walking, crawling, etc. Many "infinity pools" are built with the infinity edge of the pool on the side of a cliff or at the edge of a building where people simply cannot access. It makes no practical sense to put a bonding grid on the side of a cliff or at the edge of a building where it may be impossible for people to go. The informational note is added for guidance.

Related Public Inputs for This Document

<u>Related Input</u>	<u>Relationship</u>
<u>Public Input No. 278-NFPA 70-2023 [Section No. 680.26(B)(2)]</u>	perimeter bonding exceptions

Submitter Information Verification

Submitter Full Name: Russ Leblanc
Organization: Leblanc Consulting Services
Street Address:
City:
State:
Zip:
Submittal Date: Fri Feb 03 13:05:29 EST 2023
Committee: NEC-P17

Committee Statement

Resolution: The proposed revisions from this public input were based on 2023 NEC 680.26 text existing prior to the issuance of TIA 23-9. The objectives of the submitter were accomplished by TIA 23-9. Therefore, no revisions were made.

680.26 Perimeter Bonding



680.26 Perimeter Bonding



Perimeter bonding
applies here



680.26 Perimeter Bonding

“Exception: Perimeter bonding shall not be required for perimeter surface areas with no access for personnel to walk, crawl, or otherwise traverse that area.”

Perimeter bonding applies here



680.26 Perimeter Bonding

Informational note: Infinity pools are an example where the infinity edge of the pool may not have any access for personnel to traverse the area outside of that edge.”





Public Input No. 770-NFPA 70-2023 [Section No. 680.26(B)(2)]

(2) Perimeter Surfaces.

The perimeter surface to be bonded shall be considered to extend for 900 mm (3 ft) horizontally beyond the inside walls of the pool while also at a height between 900 mm (3 ft) above and 600 mm (2 ft) below the maximum water level. The perimeter surface shall include unpaved surfaces, concrete, and other types of paving. Perimeter surfaces separated from the pool by a permanent wall or building 1.5 m (5 ft) in height or more shall require equipotential bonding only on the pool side of the permanent wall or building. Bonding to perimeter surfaces shall be provided as specified in 680.26(B)(2)(a), (B)(2)(b), (B)(2)(c), and (B)(2)(d). For conductive pool shells where bonding to perimeter surfaces is required, it shall be attached to the pool reinforcing steel or copper conductor grid at a minimum of four points uniformly spaced around the perimeter of the pool, or if the bonded perimeter surface does not surround the entire pool, it shall be attached to the pool reinforcing steel or copper conductor grid at a minimum of four uniformly spaced points along the bonded perimeter surface. For nonconductive pool shells, where bonding to the perimeter surfaces is required, bonding at four points shall not be required, and the perimeter bonding shall be attached to the 8 AWG copper equipotential bonding conductor and, if present, to any conductive support structure for the pool.

Informational Note: Because the perimeter surface can incorporate various types of materials at various locations and elevations above and below maximum water level, the perimeter surface required to be bonded might not surround the entire pool. The 8 AWG copper equipotential bonding conductor can encircle the entire pool to facilitate connection of bonded parts.

(a) *Conductive Paved Portions of Perimeter Surfaces.* Conductive paved portions of perimeter surfaces, including masonry pavers, if used, shall be bonded with unencapsulated structural reinforcing steel in accordance with 680.26(B)(1)(a), or with unencapsulated steel structural welded wire reinforcement (welded wire mesh, welded wire fabric), bonded together by steel tie wires or the equivalent. Steel welded wire reinforcement shall be fully embedded within the pavement unless the pavement will not allow for embedding. If the reinforcing steel is absent, or is encapsulated in a nonconductive compound, or embedding is not possible, unencapsulated welded wire steel reinforcement or a copper conductor grid shall be provided and shall be secured directly under the paving, and not more than 150 mm (6 in.) below finished grade.

Unencapsulated steel welded wire reinforcement that is not fully embedded in concrete, and copper grid regardless of location, where used for equipotential bonding, shall be listed for corrosion resistance and mechanical performance. This listing requirement shall become effective January 1, 2025. The copper grid or unencapsulated steel welded wire reinforcement shall also meet the following:

- (1) Copper grid is constructed of 8 AWG solid bare copper and arranged in accordance with 680.26(B)(1)(b)(3).
- (2) Steel welded wire reinforcement is minimum ASTM 6 × 6-W2.0 × W2.0 or minimum No. 3 rebar constructed in a 300 mm (12 in.) grid.
- (3) Copper grid and steel welded wire reinforcement follow the contour of the perimeter surface extending not less than 900 mm (3 ft) horizontally beyond the inside walls of the pool.
- (4) Only listed splicing devices or exothermic welding are used.

Informational Note No. 1: Performance of the equipotential bonding system at the perimeter surface is improved as the distance between the bonding means and finished grade is minimized, either by embedding within, or by direct contact with the underside of, the finished pavement.

Informational Note No. 2: See ASTM A615/A615M, *Standard Specification for Deformed and Plain Carbon-Steel Bars for Concrete Reinforcement*; A1064/A1064M, *Standard Specification for Carbon-Steel Wire and Welded Wire Reinforcement, Plain and Deformed, for Concrete*; A1022/A1022M, *Standard Specification for Deformed and Plain Stainless Steel Wire and Welded Wire for Concrete Reinforcement*; A1060A/A1060M, *Standard Specification for Zinc-Coated (Galvanized) Steel Welded Wire Reinforcement, Plain and Deformed, for Concrete*; and ACI Standard ACI 318, *Building Code Requirements for Structural Concrete*, for examples of standards currently used in the listing of reinforcing steel bars and steel welded wire reinforcement.

(b) *Unpaved Portions of Perimeter Surfaces.* Unpaved portions of perimeter surfaces shall be bonded with any of the following methods:

- (3) Copper conductor(s) shall meet the following:
- (4) At least one minimum 8 AWG bare solid copper conductor, including the 8 AWG copper equipotential bonding conductor if available.
 - (5) The conductors follow the contour of the perimeter surface.
 - (6) Only listed splicing devices or exothermic welding are used.
 - (7) The conductor(s) is 450 mm to 600 mm (18 in. to 24 in.) from the inside walls of the pool.
 - (8) The conductor(s) is under the unpaved portion of the perimeter surface 100 mm to 150 mm (4 in. to 6 in.) below finished grade.
 - (9) Be installed only in perimeter surfaces not intended to have direct access to swimmers in the pool.
- (10) Copper grid or unencapsulated steel welded wire reinforcement used for equipotential bonding of unpaved portions of perimeter surfaces shall meet the following:
- (11) Be installed in accordance with 680.26(B)(2)(a) .
 - (12) Be located within unpaved surface(s) between 100 mm to 150 mm (4 in. to 6 in.) below finished grade.

(m) *Nonconductive Perimeter Surfaces.* Equipotential bonding shall not be required for nonconductive portions of perimeter surfaces that are separated from earth or raised on nonconducting supports, and it shall not be required for any perimeter surface that is electrically separated from the pool structure and raised on nonconductive supports above an equipotentially bonded surface.

Informational Note: Nonconductive materials include, but are not limited to, wood, plastic, wood-plastic composites, fiberglass, and fiberglass composites. Perimeter surfaces that are electrically separated from the pool structure and raised on nonconductive supports above an equipotentially bonded surface include, but are not limited to, metal fittings and metal components fixed to bulkheads constructed of nonconductive materials with no conductive connection to the pool structure by the bulkhead and/or metal fittings and components fixed to the bulkhead.

(n) *Interconnection of Bonded Portions of Perimeter Surfaces.* All surfaces where equipotential bonding is required shall be interconnected using listed splicing devices or exothermic welding. Where copper wire is used for this purpose, it shall be solid copper, not smaller than 8 AWG. The conductor shall be permitted to encircle the pool to facilitate bonding connections to portions of the perimeter covered in 680.26(B)(2)(a) and (B)(2)(b) that are not contiguous.

Statement of Problem and Substantiation for Public Input

Currently the NEC code does not contain any verbiage around swimming pool bulkheads, particularly bulkheads constructed of nonconductive material (fiberglass). The addition of the proposed verbiage would serve to clarify how a bulkhead is classified, as well as the bonding requirements for fixed metal components that are fixed to nonconductive surfaces/structures with no electrical path to ground or to the pool structure.

Equipotential bonding is to prevent stray currents from being transferred to conductive surfaces with an unequal ground potential. If the surfaces are electrically isolated from a ground path, then I believe this

clause is saying there is no need to bond these surfaces. I believe this is the intent of the second part of this clause "..., and it shall not be required for any perimeter surface that is electrically separated from the pool structure and raised on nonconductive supports above an equipotentially bonded surface."

Submitter Information Verification

Submitter Full Name: Philip Escobedo
Organization: FLUIDRA
Affiliation: FLUIDRA
Street Address:
City:
State:
Zip:
Submittal Date: Wed May 03 21:11:11 EDT 2023
Committee: NEC-P17

Committee Statement

Resolution: [FR-9267-NFPA 70-2024](#)

Statement: In 680.26(B)(5), "Metal Structures" was added to the title "Metal Fittings" to address items such as bulkheads. Moveable bulkheads are common especially in large commercial and institutional pools. This clarifies that conductive bulkheads must be bonded. Exception 4 was added to provide relief for conductive components attached to nonconductive bulkheads. These are often constructed of nonconductive materials, with limited metal fittings and attachments such as handles or starting blocks. When isolated from the pool structure and other conductive parts, these present minimal risk of electric shock and are not required to be bonded.



Public Input No. 1215-NFPA 70-2023 [New Section after 680.26(B)(7)]

TITLE OF NEW CONTENT

Metal Fencing Bonding

Type your content here ...If a metal fence is bonded due to being five feet or less from the inside wall of the pool a bonding surface shall be installed 18 too 24 inches from the exterior of the fence as per 680.26 (B)(2).

Statement of Problem and Substantiation for Public Input

The NEC is always concerned with safety and what I see here is that any gradients in the pool area outside the fenced area could create a hazard with the bonded fence.

Submitter Information Verification

Submitter Full Name: Lou Petrucci

Organization: [Not Specified]

Street Address:

City:

State:

Zip:

Submittal Date: Tue Jun 27 13:13:53 EDT 2023

Committee: NEC-P17

Committee Statement

Resolution: Section 680.26 presently requires equipotential bonding for the area in proximity to a pool. Insufficient technical substantiation has been presented to support the proposed change.



Public Input No. 3214-NFPA 70-2023 [Section No. 680.26(B)(7)]

(7) Fixed Metal Parts.

All fixed metal parts, including, but not limited to, metal-sheathed cables and raceways, metal piping, metal awnings, metal fences, and metal door and window frames, shall be bonded where located no greater than either of the following:

- (1) 1.5 m (5 ft) horizontally from the inside walls of the pool or bonded metal part
- (2) 3.7 m (12 ft) vertically above the maximum water level of the pool, observation stands, towers, or platforms, or any diving structures

Exception: Those separated from the pool by a permanent barrier that prevents contact by a person shall not be required to be bonded.

Statement of Problem and Substantiation for Public Input

The intent of adding the text 'or bonded metal part' to the requirement is to take into consideration of a bonded handrail that within three feet from a screen enclosure. The shock hazard will be present to a person standing in between a bonded metal part and a unbonded metal part further than 5ft form the inside walls of the pool. The 5ft horizontal measurement in this case should begin from the bonded metal part. This proposed revision will increase electrical safety around pools.

Submitter Information Verification

Submitter Full Name: Mike Holt
Organization: Mike Holt Enterprises Inc
Street Address:
City:
State:
Zip:
Submittal Date: Wed Aug 30 11:40:13 EDT 2023
Committee: NEC-P17

Committee Statement

Resolution: No technical substantiation was provided to support the proposed change. The proposal is impractical and would require bonding of all metal parts that are within 5 feet of each other (rather than within 5 feet of the pool), regardless of their function, creating in some foreseeable cases a “daisy chain” of now-required-to-be-bonded metal parts that could reach far from the pool and even off the property.



Public Input No. 1737-NFPA 70-2023 [Section No. 680.26(B) [Excluding any Sub-Sections]]

The parts specified in 680.26(B)(1) through (B)(7) shall be bonded together using one or more of the following

(1) solid copper conductors, insulated, covered, or bare, not smaller than 8 AWG- ~~or with~~ , which shall not be required to be extended or attached to remote panelboards, service equipment, or electrodes

(2) rigid metal conduit of brass or other identified corrosion-resistant metal-

(3) structural reinforcing steel

(4) steel structural welded wire reinforcement (welded wire mesh, welded wire fabric)

Connections to bonded parts shall be made in accordance with 250.8 ~~-An 8 AWG or larger solid copper bonding conductor provided to reduce voltage gradients in the pool area shall not be required to be extended or attached to remote panelboards, service equipment, or electrodes- and 680.7(C).~~

Statement of Problem and Substantiation for Public Input

This PI proposes to restructure this section and add references to structural steel and wire:

- 1- restructured to a list format for clarity to make it easier to read and understand
- 2- structural reinforcing steel and steel structural welded wire reinforcement are added as options as they are included in 680.26(B)(2)
- 3- a reference to 680.7(C) is added for clarity to remind users of the Code that field installed terminals and connections must comply with both Article 250 and 680 requirements
- 4- the requirement for not requiring the 8 AWG conductor to be extended or attached to remote panelboards, service equipment, or electrodes is moved to new list item (1) in order to consolidate similar information

Submitter Information Verification

Submitter Full Name: Vincent Della Croce

Organization:

Street Address:

City:

State:

Zip:

Submittal Date: Mon Jul 31 13:43:23 EDT 2023

Committee: NEC-P17

Committee Statement

Resolution: FR-9239-NFPA 70-2024

Statement: Revisions to this section include:

Informational Note 1 to 680.26(A) was revised to comply with 2.1.10 of the NEC Style Manual.

Informational Note 2 to 680.26(A) was deleted as it did not add clarity to the requirements. Corrosive environments are already addressed in 680.14, and performance requirements are already addressed in 680.26(A). Therefore, this language is not needed.

Section 680.26(B) was editorially revised into a list format for ease of reading, in accordance with 3.5.2 of the NEC Style Manual. New text was added to clarify that structural reinforcing steel and steel structural welded wire reinforcement are permitted options for bonding. These options were inferred but not explicitly stated.

Section 680.26(B) was revised by changing “panelboard” to “panelboard enclosure” for accuracy.

Multiple editorial changes were made to 680.26(B)(2) for clarification and readability; and redundant language, including 680.26(B)(2)(d), was eliminated. The word “conductor” was added to the phrase “copper grid” in multiple locations for consistency, as was adding the word “structural” to the phrase “reinforcing steel.”

An allowance for a copper conductor grid was added in 680.26(B)(2)(a)(2) because a copper conductor grid should be a permitted method of achieving the bonding contemplated in this section.



Public Input No. 2018-NFPA 70-2023 [Section No. 680.26(B) [Excluding any Sub-Sections]]

The parts specified in 680.26(B)(1) through (B)(7) shall be bonded together using solid copper or 40% copper-clad steel conductors, insulated, covered, or bare, not smaller than 8 AWG or with rigid metal conduit of brass or other identified corrosion-resistant metal. Connections to bonded parts shall be made in accordance with 250.8. An 8 AWG or larger solid copper or 40% copper-clad steel bonding conductor provided to reduce voltage gradients in the pool area shall not be required to be extended or attached to remote panelboards, service equipment, or electrodes.

Statement of Problem and Substantiation for Public Input

Please see the substantiation in Public Input 1102.

Submitter Information Verification

Submitter Full Name: Peter Graser
Organization: Copperweld
Affiliation: American Bimetallic Association
Street Address:
City:
State:
Zip:
Submittal Date: Fri Aug 11 07:23:03 EDT 2023
Committee: NEC-P17

Committee Statement

Resolution: CMP17 has concerns including corrosion at the ends of copper-clad steel conductors and copper-clad reinforcing steel installed in concrete, earth, or other corrosive environments. CMP17 also requests data showing how the product reacts to exothermic welding, as that process is a permitted method of connection in this section.



Public Input No. 2083-NFPA 70-2023 [Section No. 680.26(B) [Excluding any Sub-Sections]]

The parts specified in 680.26(B)(1) through (B)(7) shall be bonded together using solid copper conductors, insulated, covered, or bare, not smaller than 8 AWG or with rigid metal conduit of brass or other identified corrosion-resistant metal. Connections to bonded parts shall be made in accordance with 250.8. An 8 AWG or larger solid copper bonding conductor provided to reduce voltage gradients in the pool area shall not be required to be extended or attached to remote enclosed panelboards, service equipment, or electrodes.

Statement of Problem and Substantiation for Public Input

The term 'panelboard' and 'enclosed panelboard' are defined terms. Adding the word 'enclosed panelboard' makes the text technically correct. Note: The term 'Enclosed Panelboard' was added to NEC Article 100 during the 2023 Code cycle.

Submitter Information Verification

Submitter Full Name: Mike Holt
Organization: Mike Holt Enterprises Inc
Street Address:
City:
State:
Zip:
Submittal Date: Fri Aug 11 15:35:37 EDT 2023
Committee: NEC-P17

Committee Statement

Resolution: [FR-9239-NFPA 70-2024](#)

Statement: Revisions to this section include:

Informational Note 1 to 680.26(A) was revised to comply with 2.1.10 of the NEC Style Manual.

Informational Note 2 to 680.26(A) was deleted as it did not add clarity to the requirements. Corrosive environments are already addressed in 680.14, and performance requirements are already addressed in 680.26(A). Therefore, this language is not needed.

Section 680.26(B) was editorially revised into a list format for ease of reading, in accordance with 3.5.2 of the NEC Style Manual. New text was added to clarify that structural reinforcing steel and steel structural welded wire reinforcement are permitted options for bonding. These options were inferred but not explicitly stated.

Section 680.26(B) was revised by changing "panelboard" to "panelboard enclosure" for accuracy.

Multiple editorial changes were made to 680.26(B)(2) for clarification and readability; and redundant language, including 680.26(B)(2)(d), was eliminated. The word "conductor"

was added to the phrase “copper grid” in multiple locations for consistency, as was adding the word “structural” to the phrase “reinforcing steel.”

An allowance for a copper conductor grid was added in 680.26(B)(2)(a)(2) because a copper conductor grid should be a permitted method of achieving the bonding contemplated in this section.



Public Input No. 2468-NFPA 70-2023 [New Section after 680.28]

680.29 Portable Signs

A portable electric sign shall not be placed within a pool or within 1.5 m (5 ft) measured horizontally from the inside walls of a pool.

Statement of Problem and Substantiation for Public Input

This PI proposes to relocate a pool specific requirement from 680.57(C)(2) in Part V Fountains. See companion PI 2467. Part V is specific to fountains only and a pool requirement should be located in Part II.

Related Public Inputs for This Document

<u>Related Input</u>	<u>Relationship</u>
<u>Public Input No. 2467-NFPA 70-2023 [Section No. 680.57(C)(2)]</u>	

Submitter Information Verification

Submitter Full Name: Vincent Della Croce
Organization:
Street Address:
City:
State:
Zip:
Submittal Date: Thu Aug 17 15:06:46 EDT 2023
Committee: NEC-P17

Committee Statement

Resolution: FR-9129-NFPA 70-2024

Statement: Currently, 680.57(C)(2) in Part V Fountains contains a pool specific requirement, regarding Portable Signs. This is being added as new 680.29 in Part II of Article 680.



Public Input No. 2489-NFPA 70-2023 [New Section after 680.28]

680.29 – Electric Water Heaters

Circuits serving electric water heaters operating at voltages above the low-voltage contact limit shall be provided with ground fault circuit protection for personnel.

Statement of Problem and Substantiation for Public Input

Permanent swimming pools can and are heated using an electric water heaters. Clear straightforward protection similar to that afforded to gas-fired water heaters should be provided for electric water heaters.

Submitter Information Verification

Submitter Full Name: Gary Hein

Organization: [Not Specified]

Street Address:

City:

State:

Zip:

Submittal Date: Fri Aug 18 12:26:23 EDT 2023

Committee: NEC-P17

Committee Statement

Resolution: No substantiation was provided to support the expansion of GFCI protection at this time. There are engineering differences between electric and gas water heaters. For example, electric water heaters have leakage current collection and gas water heaters do not have this protection.



Public Input No. 2453-NFPA 70-2023 [Section No. 680.28]

680.28 Gas-Fired Water Heater.

Circuits serving gas-fired swimming pool ~~and spa~~ water heaters operating at voltages above the low-voltage contact limit shall be provided with GFCI protection.

Statement of Problem and Substantiation for Public Input

The requirement for spas is covered under Article 680.44 (C). 680.28 – is dedicated to Part II Permanently Installed Pools. Spas are covered under Parts III and IV. Article 680.40 (Part IV) notes that “Electrical installations at spas and hot tubs shall comply with the provisions of Part 1 and Part IV of this article.”.

- Article 680.40 does not reference compliance with article 680.28 which falls under Part II.

Submitter Information Verification

Submitter Full Name: Gary Hein

Organization: [Not Specified]

Street Address:

City:

State:

Zip:

Submittal Date: Thu Aug 17 12:54:11 EDT 2023

Committee: NEC-P17

Committee Statement

Resolution: Spas can be constructed as part of a permanently installed pool or stand-alone. This requirement is specific to a spa constructed as part of a permanently installed pool and is retained for clarity.



Public Input No. 2440-NFPA 70-2023 [Section No. 680.32]

680.32 Ground-Fault Circuit-Interrupter (GFCI) and Special Purpose Ground-Fault Circuit-Interrupter (SPGFCI) Protection.

All electrical equipment, including power-supply cords, used with storable pools shall have GFCI protection complying with 680.5(B) or SPGFCI protection complying with 680.5(C), as applicable.

All receptacles- ~~rated 125 volts through 250 volts~~ , 60 amperes or less, located within 6.0 m (20 ft) of the inside walls of a storable pool, storable spa, or storable hot tub shall have GFCI protection complying with 680.5(B) or SPGFCI protection complying with 680.5(C), as applicable. In determining these dimensions, the distance to be measured shall be the shortest path the supply cord of an appliance connected to the receptacle would follow without piercing a floor, wall, ceiling, doorway with hinged or sliding door, window opening, or other effective permanent barrier.

Statement of Problem and Substantiation for Public Input

Removing 'rated 125 volt through 250 volt' so this requirement would apply to 480V receptacles located within 20 feet of pool water. This enhances electrical safety in these areas where the shock hazard is increased.

Submitter Information Verification

Submitter Full Name: Mike Holt
Organization: Mike Holt Enterprises Inc
Street Address:
City:
State:
Zip:
Submittal Date: Thu Aug 17 12:03:28 EDT 2023
Committee: NEC-P17

Committee Statement

Resolution: [FR-9143-NFPA 70-2024](#)

Statement: Section 680.32 currently stipulates a 60-ampere threshold for equipment requiring ground-fault circuit interrupter (GFCI) protection. Commercially available three-phase GFCI devices now offer ratings up to 100 amperes. This revision reflects the availability of higher-rated GFCI devices and harmonizes the code with existing provisions, such as 210.8(B). Additionally, 680.32 was separated into a list for improved usability.



Public Input No. 2441-NFPA 70-2023 [Section No. 680.32]

680.32 Ground-Fault Circuit-Interrupter (GFCI) and Special Purpose Ground-Fault Circuit-Interrupter (SPGFCI) Protection.

(A) Equipment. All electrical equipment, including power-supply cords, used with storable pools shall have GFCI protection complying with 680.5(B) or SPGFCI protection complying with 680.5(C), as applicable.

(B) Receptacles. All receptacles rated 125 volts through 250 volts, 60 amperes or less, located within 6.0 m (20 ft) of the inside walls of a storable pool, storable spa, or storable hot tub shall have GFCI protection complying with 680.5(B) or SPGFCI protection complying with 680.5(C), as applicable. In determining these dimensions, the distance to be measured shall be the shortest path the supply cord of an appliance connected to the receptacle would follow without piercing a floor, wall, ceiling, doorway with hinged or sliding door, window opening, or other effective permanent barrier.

Statement of Problem and Substantiation for Public Input

Created two first level subdivisions to separate these two requirements to facilitate useability for Code users. In accordance with NEC Style Manual section 3.5.1.2 multiple requirements within a single subdivision shall be avoided. Additional subdivisions or lists shall be used to express independent requirements.

Submitter Information Verification

Submitter Full Name: Mike Holt
Organization: Mike Holt Enterprises Inc
Street Address:
City:
State:
Zip:
Submittal Date: Thu Aug 17 12:04:35 EDT 2023
Committee: NEC-P17

Committee Statement

Resolution: [FR-9143-NFPA 70-2024](#)

Statement: Section 680.32 currently stipulates a 60-ampere threshold for equipment requiring ground-fault circuit interrupter (GFCI) protection. Commercially available three-phase GFCI devices now offer ratings up to 100 amperes. This revision reflects the availability of higher-rated GFCI devices and harmonizes the code with existing provisions, such as 210.8(B). Additionally, 680.32 was separated into a list for improved usability.



Public Input No. 2518-NFPA 70-2023 [Section No. 680.32]

680.32 Ground-Fault Circuit-Interrupter (GFCI) and Special Purpose Ground-Fault Circuit-Interrupter (SPGFCI) Protection.

All electrical equipment, including power-supply cords, used with storable pools shall have GFCI protection complying with 680.5(B) or SPGFCI protection complying with 680.5(C), as applicable.

All receptacles ~~rated 125 volts through 250 volts~~ supplied by branch circuits rated 150 volts or less to ground, 60 amperes or less, located within 6.0 m (20 ft) of the inside walls of a storable pool, storable spa, or storable hot tub shall have GFCI protection complying with 680.5(B) or SPGFCI protection complying with 680.5(C), as applicable. In determining these dimensions, the distance to be measured shall be the shortest path the supply cord of an appliance connected to the receptacle would follow without piercing a floor, wall, ceiling, doorway with hinged or sliding door, window opening, or other effective permanent barrier.

Statement of Problem and Substantiation for Public Input

This change is so this language is consistent with that in 680.5(B) and many other locations in the code where "rated 125 volts through 250 volts" has been replaced. Having different language trying to describe the same thing is confusion for the code user. Also there are rare cases where a receptacle rated 250 volts could be supplied by a branch circuit that has a voltage greater than 150 volts to ground, a case the is beyond the design rating of a GFCI.

Submitter Information Verification

Submitter Full Name: Don Ganiere

Organization: none

Street Address:

City:

State:

Zip:

Submittal Date: Sat Aug 19 10:27:20 EDT 2023

Committee: NEC-P17

Committee Statement

Resolution: [FR-9143-NFPA 70-2024](#)

Statement: Section 680.32 currently stipulates a 60-ampere threshold for equipment requiring ground-fault circuit interrupter (GFCI) protection. Commercially available three-phase GFCI devices now offer ratings up to 100 amperes. This revision reflects the availability of higher-rated GFCI devices and harmonizes the code with existing provisions, such as 210.8(B). Additionally, 680.32 was separated into a list for improved usability.



Public Input No. 3814-NFPA 70-2023 [Section No. 680.32]

680.32 Ground-Fault Circuit-Interrupter (GFCI) and Special Purpose Ground-Fault Circuit-Interrupter (SPGFCI) Protection.

All electrical equipment, including power-supply cords, used with storable pools shall have GFCI protection complying with 680.5(B) or SPGFCI protection complying with 680.5(C), as applicable.

All receptacles rated 125 volts through 250 volts, 60 amperes or less, located within 6.0 m (20 ft) of the inside walls of a storable pool, storable spa, or storable hot tub shall have GFCI protection complying with 680.5(B) ~~or SPGFCI protection complying with 680.5(C), as applicable.~~ In determining these dimensions, the distance to be measured shall be the shortest path the supply cord of an appliance connected to the receptacle would follow without piercing a floor, wall, ceiling, doorway with hinged or sliding door, window opening, or other effective permanent barrier.

Statement of Problem and Substantiation for Public Input

This language is in conflict with the definition of a SPCGFCI. Article 100 defines the SPCGFCI as “A device intended for the detection of ground-fault currents, used in circuits with voltage to ground greater than 150 volts, that functions to de-energize a circuit or portion of a circuit within an established period of time when a ground-fault current exceeds the values established for Class C, D, or E devices. (CMP-2)”. This section speaks specifically to receptacles rated 125 volts through 250 volts. A receptacle on a circuit protected by a SPGFCI would need to be rated 480 volts which is beyond the requirements of this section.

Submitter Information Verification

Submitter Full Name: Thomas Domitrovich
Organization: Eaton Corporation
Street Address:
City:
State:
Zip:
Submittal Date: Tue Sep 05 17:40:59 EDT 2023
Committee: NEC-P17

Committee Statement

Resolution: The existing code language is not in conflict with the definition of a SPGFCI and the existing requirement is technically correct. Single- and three-phase receptacles rated 250-volts installed on 240-volt corner grounded delta systems or involving the high leg of a 120/240-volt 4-wire delta connected system have a voltage to ground greater than 150-volts and require SPGFCI (rather than GFCI) protection. These systems are discussed in the existing Informational Note to 680.5(B). Additional first revisions to this and other sections of Article 680 are being made to clarify that the range of voltages associated with SPGFCI includes 480V.



Public Input No. 4518-NFPA 70-2023 [Section No. 680.32]

680.32 Ground-Fault Circuit-Interrupter (GFCI) and Special Purpose Ground-Fault Circuit-Interrupter (SPGFCI) Protection.

All electrical equipment, including power-supply cords, used with storable pools shall have GFCI protection complying with 680.5(B) or SPGFCI protection complying with 680.5(C), as applicable.

All receptacles rated 125 volts through 250 volts, 60 amperes or less single-phase, or 100 amperes or less three-phase, located within 6.0 m (20 ft) of the inside walls of a storable pool, storable spa, or storable hot tub shall have GFCI protection complying with 680.5(B) or SPGFCI protection complying with 680.5(C), as applicable. In determining these dimensions, the distance to be measured shall be the shortest path the supply cord of an appliance connected to the receptacle would follow without piercing a floor, wall, ceiling, doorway with hinged or sliding door, window opening, or other effective permanent barrier.

Statement of Problem and Substantiation for Public Input

Equipment is now being used that is above the 60 A value currently stated in the code. GFCI devices are commercially available at the 100 A rating, and moving the three-phase limit to 100 A correlates to other parts of the code such as 210.8(B).

Related Public Inputs for This Document

<u>Related Input</u>	<u>Relationship</u>
<u>Public Input No. 4500-NFPA 70-2023 [Section No. 680.5(B)]</u>	

Submitter Information Verification

Submitter Full Name: Mark Pollock
Organization: Littelfuse
Street Address:
City:
State:
Zip:
Submittal Date: Thu Sep 07 16:49:26 EDT 2023
Committee: NEC-P17

Committee Statement

Resolution: FR-9143-NFPA 70-2024

Statement: Section 680.32 currently stipulates a 60-ampere threshold for equipment requiring ground-fault circuit interrupter (GFCI) protection. Commercially available three-phase GFCI devices now offer ratings up to 100 amperes. This revision reflects the availability of higher-rated GFCI devices and harmonizes the code with existing provisions, such as 210.8(B). Additionally, 680.32 was separated into a list for improved usability.



Public Input No. 1286-NFPA 70-2023 [Section No. 680.40]

680.40 General.

Electrical installations at spas and hot tubs shall comply ~~with the provisions of Part I~~ with Part I and Part IV of this article.

Statement of Problem and Substantiation for Public Input

The deleted text "The provisions of" is unnecessary and adds no value. The Correlating Committee directed the Code Panels to remove this text where found in previous editions. This occurrence of the text was overlooked.

Submitter Information Verification

Submitter Full Name: John Kovacik
Organization: Trusted Safety Solutions LLC
Street Address:
City:
State:
Zip:
Submittal Date: Thu Jul 06 13:26:21 EDT 2023
Committee: NEC-P17

Committee Statement

Resolution: [FR-9158-NFPA 70-2024](#)

Statement: The text is revised to comply with the NEC style manual Section 4.1.3.

**Public Input No. 2442-NFPA 70-2023 [Section No. 680.43(A)(2)]**

(2) Ground-Fault Circuit-Interrupter (GFCI) and Special Purpose Ground-Fault Circuit-Interrupter (SPGFCI) Protection for Receptacles, General.

All receptacles ~~rated 125 volts through 250 volts~~, 60 amperes or less, located within 3.0 m (10 ft) of the inside walls of a spa or hot tub shall have GFCI protection complying with 680.5(B) or SPGFCI protection complying with 680.5(C), as applicable.

Statement of Problem and Substantiation for Public Input

Removing 'rated 125 volt through 250 volt' so this requirement would apply to 480V receptacles located within 20 feet of pool water. This enhances electrical safety in these areas where the shock hazard is increased.

Submitter Information Verification

Submitter Full Name: Mike Holt

Organization: Mike Holt Enterprises Inc

Street Address:

City:

State:

Zip:

Submittal Date: Thu Aug 17 12:07:45 EDT 2023

Committee: NEC-P17

Committee Statement

Resolution: [FR-9160-NFPA 70-2024](#)

Statement: Section 680.43(A)(2) currently stipulates a 60-ampere threshold for equipment requiring ground-fault circuit interrupter (GFCI) protection. Commercially available three-phase GFCI devices now offer ratings up to 100 amperes. This revision reflects the availability of higher-rated GFCI devices and harmonizes the code with existing provisions, such as 210.8(B). Additionally, 680.43(A)(2) was separated into a list for improved usability.



Public Input No. 3815-NFPA 70-2023 [Section No. 680.43(A)(2)]

~~(2) Ground-Fault Circuit-Interrupter (GFCI) and Special Purpose Ground-Fault Circuit-Interrupter (SPGFCI) Protection for~~ for Receptacles, General.

All receptacles rated 125 volts through 250 volts, 60 amperes or less, located within 3.0 m (10 ft) of the inside walls of a spa or hot tub shall have GFCI protection complying with 680.5(B) ~~or SPGFCI protection complying with 680.5(C), as applicable.~~

Statement of Problem and Substantiation for Public Input

This language is in conflict with the definition of a SPCGFCI. Article 100 defines the SPCGFCI as “A device intended for the detection of ground-fault currents, used in circuits with voltage to ground greater than 150 volts, that functions to de-energize a circuit or portion of a circuit within an established period of time when a ground-fault current exceeds the values established for Class C, D, or E devices. (CMP-2)”. This section speaks specifically to receptacles rated 125 volts through 250 volts. A receptacle on a circuit protected by a SPGFCI would need to be rated 480 volts which is beyond the requirements of this section.

Submitter Information Verification

Submitter Full Name: Thomas Domitrovich
Organization: Eaton Corporation
Street Address:
City:
State:
Zip:
Submittal Date: Tue Sep 05 17:43:25 EDT 2023
Committee: NEC-P17

Committee Statement

Resolution: The existing code language is not in conflict with the definition of a SPGFCI and the existing requirement is technically correct. Single- and three-phase receptacles rated 250-volts installed on 240-volt corner grounded delta systems or involving the high leg of a 120/240-volt 4-wire delta connected system have a voltage to ground greater than 150-volts and require SPGFCI (rather than GFCI) protection. These systems are discussed in the existing Informational Note to 680.5(B). Additional first revisions to this and other sections of Article 680 are being made to clarify that the range of voltages associated with SPGFCI includes 480V.



Public Input No. 4520-NFPA 70-2023 [Section No. 680.43(A)(2)]

(2) Ground-Fault Circuit-Interrupter (GFCI) and Special Purpose Ground-Fault Circuit-Interrupter (SPGFCI) Protection for Receptacles, General.

All receptacles rated 125 volts through 250 volts, 60 amperes or less single-phase, or 100 amperes or less 3-phase, located within 3.0 m (10 ft) of the inside walls of a spa or hot tub shall have GFCI protection complying with 680.5(B) or SPGFCI protection complying with 680.5(C), as applicable.

Statement of Problem and Substantiation for Public Input

Equipment is now being used that is above the 60 A value currently stated in the code. GFCI devices are commercially available at the 100 A rating, and moving the three-phase limit to 100 A correlates to other parts of the code such as 210.8(B).

Related Public Inputs for This Document

<u>Related Input</u>	<u>Relationship</u>
Public Input No. 4500-NFPA 70-2023 [Section No. 680.5(B)]	

Submitter Information Verification

Submitter Full Name: Mark Pollock
Organization: Littelfuse
Street Address:
City:
State:
Zip:
Submittal Date: Thu Sep 07 16:51:18 EDT 2023
Committee: NEC-P17

Committee Statement

Resolution: FR-9160-NFPA 70-2024

Statement: Section 680.43(A)(2) currently stipulates a 60-ampere threshold for equipment requiring ground-fault circuit interrupter (GFCI) protection. Commercially available three-phase GFCI devices now offer ratings up to 100 amperes. This revision reflects the availability of higher-rated GFCI devices and harmonizes the code with existing provisions, such as 210.8(B). Additionally, 680.43(A)(2) was separated into a list for improved usability.



Public Input No. 4476-NFPA 70-2023 [Section No. 680.43(A)(3)]

(3)– GFCI Protection, Spa or Hot Tub Supply Receptacle.

Receptacles that provide power for a spa or hot tub shall not exceed 150 volts to ground and shall be GFCI protected.

Statement of Problem and Substantiation for Public Input

Adding 'GFCI' to the section title in order to match the technical requirement. In accordance with NEC style manual section 2.1.3.2 the title must be descriptive and concise with the intent of the requirement.

Submitter Information Verification

Submitter Full Name: Mike Holt

Organization: Mike Holt Enterprises Inc

Street Address:

City:

State:

Zip:

Submittal Date: Thu Sep 07 16:10:24 EDT 2023

Committee: NEC-P17

Committee Statement

Resolution: [FR-9164-NFPA 70-2024](#)

Statement: The word "Protection" was removed from title of 680.43(A)(3) to better align the title with the requirements in the text.



Public Input No. 2270-NFPA 70-2023 [Section No. 680.43(F)]

(F)– Connection to Equipment Grounding Conductor .

The following equipment shall be connected to the equipment grounding conductor:

- (1) All electrical equipment located within 1.5 m (5 ft) of the inside wall of the spa or hot tub
- (2) All electrical equipment associated with the circulating system of the spa or hot tub

Exception to (1) and (2): Electrical equipment listed for operation at the low-voltage contact limit or less and supplied by a transformer or power supply that complies with 680.23(A)(2) shall not be required to be connected to the equipment grounding conductor.

Statement of Problem and Substantiation for Public Input

Changing the title would make the text technically correct. This requirement is about connecting the equipment grounding conductor of the wire type to electrical equipment, not about grounding. In accordance with NEC style manual section 2.1.3.2 the title must be descriptive and concise with the intent of the requirement.

Submitter Information Verification

Submitter Full Name: Mike Holt

Organization: Mike Holt Enterprises Inc

Street Address:

City:

State:

Zip:

Submittal Date: Tue Aug 15 14:34:49 EDT 2023

Committee: NEC-P17

Committee Statement

Resolution: [FR-9165-NFPA 70-2024](#)

Statement: The Title of 680.43(F) was revised to add "Equipment" to be more descriptive and remain concise.



Public Input No. 1328-NFPA 70-2023 [Section No. 680.45(A)]

(A) Cord-and-Plug Connections.

To facilitate the removal or disconnection of the unit(s) for maintenance, storage, and ~~repair~~ servicing, self-contained portable packaged immersion pools with integral pumps and/or heaters, including circulation heaters, rated 120 volts and 20 amperes or less shall be permitted to be cord-and-plug-connected with a cord not shorter than 1.83 m (6 ft) and not longer than 4.6 m (15 ft) and shall be GFCI protected. The cord shall ground all non-current-carrying metal parts of the electrical equipment. If the GFCI is provided as an integral part of the cord assembly, it shall be located at the attachment plug or in the power-supply cord within 300 mm (12 in.) of the attachment plug.

Statement of Problem and Substantiation for Public Input

Servicing is a defined term and includes repairs. Using a defined term adds more clarity and helps avoid confusion between activities that are deemed as servicing and those that are deemed as reconditioning.

Submitter Information Verification

Submitter Full Name: Thomas Domitrovich

Organization: Eaton Corporation

Street Address:

City:

State:

Zip:

Submittal Date: Sat Jul 08 11:46:35 EDT 2023

Committee: NEC-P17

Committee Statement

Resolution: [FR-9166-NFPA 70-2024](#)

Statement: The text language regarding "To facilitate the removal or disconnection of the unit(s) for maintenance, storage, and repair" was removed. Deleting this text improves usability and does not change the requirement.



Public Input No. 1659-NFPA 70-2023 [Section No. 680.45(C)]

(C) Heaters.

Heaters used with permanently installed immersion pools shall comply with either 680.45(C)(1) or (C)(2) or (C)(3).

(1) Permanently Installed Heaters- Hard Wired

A permanently installed heater, ~~including immersion heaters, circulation heaters, and combination pump heater units, built-~~ rated 120 volts through 250 volts that is built- in or permanently attached as an integral part of a permanently installed immersion pool, ~~rated 120 volts or 250 volts, shall~~ comply with all of the following

(a) ~~be identified for swimming pool and spa use; shall~~

(b) ~~be grounded and bonded; and heaters supplied by branch circuits rated 150 volts or less to ground shall be provided with GFCI protection. Permanently installed immersion heaters,~~

(c) have GFCI protection complying with 680.5(B) or SPGFCI protection complying with 680.5(C), as applicable.

(2) Permanently Installed Heaters- Cord and Plug Connected

A permanently installed heater, rated 120 volts and 20 amperes or less or 250 volts and 30 amperes or less, single phase, are permitted to be cord-and-plug-connected and comply with all of the following

~~(a) the cord shall not be shorter than 1.83 m (6 ft) and not longer than 4.6 m (15 ft), shall be GFCI protected, and shall be provided with means for grounding all non-current-carrying metal parts of the appliance. If the GFCI~~

~~(b) if GFCI is provided as an integral part of the cord assembly, it shall be located at the attachment plug or in the power-supply cord within 300 mm (12 in.) of the attachment plug.~~

(

2)

c) have GFCI protection complying with 680.5(B) or SPGFCI protection complying with 680.5(C), as applicable.

(d) be provided with means for grounding all non-current carrying metal parts of the heater

(3) Storable and Portable Heaters.

A cord-connected storable or portable heater, ~~including immersion heaters, circulation heaters, and combination pump heater units, rated 120 volts and 20 amperes or less, or 250 volts and 30 amperes or less, single phase, used with, but not permanently installed or attached as an integral part of a permanently installed immersion pool, rated 120 volts and 20 amperes or less or 250 volts and 30 amperes or less, single phase, shall~~ shall comply with all of the following

(a) ~~be identified for swimming pool and spa use; shall~~

~~(b) be cord-and-plug-connected with a cord not shorter than 1.83 m (6 ft) and not longer than 4.6 m (15 ft), heaters supplied by branch circuits rated 150 volts or less to ground shall be provided with Class A ground-fault circuit-interrupter protection, and shall be provided with means for grounding all non-current-carrying metal parts of the appliance. If the ground-fault circuit interrupter is~~

(c) have GFCI protection complying with 680.5(B) or SPGFCI protection complying with 680.5(C), as applicable.

(d) If the GFCI is provided as an integral part of the cord assembly, it shall be located at the attachment plug or in the power-supply cord within 300 mm (12 in.) of the attachment plug.

Statement of Problem and Substantiation for Public Input

This PI proposes to restructure this section for clarity, usability and compliance with the NEC Style Manual while making no technical changes to the requirements. Section 2.1.8.1 of the Style Manual permits lists to provide additional clarity. Additional reformatting:

- 1- The requirements for permanently installed heaters are now divided into separate sections for hard wired vs cord and plug connected.
- 2- The voltage and ampere ratings are relocated to the beginning of the requirement for clarity.
- 3- The different types of heaters are deleted as "permanently installed heaters" is an all inclusive term.
- 4- The GFCI language is revised to provide a reference to 680.5 and correlate with other sections of Article 680 that reference GFCI protection

Submitter Information Verification

Submitter Full Name: Vincent Della Croce

Organization:

Street Address:

City:

State:

Zip:

Submittal Date: Thu Jul 27 17:11:48 EDT 2023

Committee: NEC-P17

Committee Statement

Resolution: [FR-9247-NFPA 70-2024](#)

Statement: This section is restructured for clarity, usability and compliance with the NEC Style Manual, section 2.1.8.1.



Public Input No. 294-NFPA 70-2023 [Section No. 680.50]

680.50 General.

Part I and Part V of this article shall apply to all permanently_ installed fountains and splash pads .

(A) Additional Requirements.

- (1) Fountains that have water common to a pool shall also comply with Part II of Article 680.
- (2) Fountains intended for recreational use by pedestrians, including splash pads, shall also comply with the requirements in 680.26.
- (3) Part V does not apply to self-contained, portable fountains, which shall comply with Parts II and III of Article 422.

(B) Location of Equipment Exceeding the Low-Voltage Contact Limit.

Equipment with ratings exceeding the low-voltage contact limit shall be located at least 1.5 m (5 ft) horizontally from the inside walls of a fountain, unless separated from the fountain by a solid fence, wall, or other permanent barrier.

Statement of Problem and Substantiation for Public Input

If the General requirements of Article 680 Part I and the requirements of Article 680 Part V do not apply to splash pads, then the charging text of 680.50 should state so explicitly and identify which requirements do not apply. The requirements for splash pads are challenging enough for NEC® users to locate; don't complicate that by omitting them from the Article 680 Part V General requirement. Splash pads have no appreciable depth and cannot be used for swimming, wading or immersion as is the case for pools and spas.

Submitter Information Verification

Submitter Full Name: Brian Rock
Organization: Hubbell Incorporated
Street Address:
City:
State:
Zip:
Submittal Date: Tue Feb 07 18:14:27 EST 2023
Committee: NEC-P17

Committee Statement

Resolution: The term "splash pads" was not added to the text in 680.50, nor added to the Title of Part V, as the definition of Fountain already includes Splash Pads, and the definition of Splash Pad indicates that a Splash pad is a fountain.



Public Input No. 2927-NFPA 70-2023 [Section No. 680.50(A)]

(A) Additional Requirements.

- (1) Fountains that have water common to a pool shall also comply with ~~Part II of Article 680~~ , Part II .
- (2) Fountains intended for recreational use by pedestrians, including splash pads, shall also comply with the requirements in 680.26.
- (3) Part V does not apply to self-contained, portable fountains, which shall comply with Article 422 , ~~Parts II and III of Article 422~~ .

Statement of Problem and Substantiation for Public Input

This Public Input is being submitted on behalf of the NEC Correlating Committee Usability Task Group in order to provide correlation throughout the document. The text is revised to to comply with the NEC Style Manual Section 4.1.4, regarding the use of Parts.

4.1.4 References to an Entire Article. References shall not be made to an entire article, except for the Article 100 or where referenced to provide the necessary context. References to specific parts within articles shall be permitted. References to all parts of an article shall not be permitted. The article number shall precede the part number.

The Usability Task Group members are: Derrick Atkins, David Hittinger, Richard Holub, Dean Hunter, Chad Kennedy and David Williams.

Submitter Information Verification

Submitter Full Name: David Williams
Organization: Delta Charter Township
Street Address:
City:
State:
Zip:
Submittal Date: Mon Aug 28 12:15:56 EDT 2023
Committee: NEC-P17

Committee Statement

Resolution: FR-9170-NFPA 70-2024

Statement: Editorial revisions are made to comply with the NEC style manual 4.1.1.



Public Input No. 2084-NFPA 70-2023 [Section No. 680.54(A)]

(A) Grounding.

The following equipment shall be connected to an equipment grounding conductor:

- (1) All electrical equipment located within the fountain or within 1.5 m (5 ft) of the inside wall of the fountain, other than listed low-voltage luminaires not requiring grounding
- (2) All electrical equipment associated with the recirculating system of the fountain
- (3) ~~Panelboards~~ Enclosed panelboards that are not part of the service equipment and that supply any electrical equipment associated with the fountain

Statement of Problem and Substantiation for Public Input

The term 'panelboard' and 'enclosed panelboard' are defined terms. Adding the word 'enclosed panelboard' makes the text technically correct. Note: The term 'Enclosed Panelboard' was added to NEC Article 100 during the 2023 Code cycle.

Submitter Information Verification

Submitter Full Name: Mike Holt

Organization: Mike Holt Enterprises Inc

Street Address:

City:

State:

Zip:

Submittal Date: Fri Aug 11 15:36:58 EDT 2023

Committee: NEC-P17

Committee Statement

Resolution: [FR-9172-NFPA 70-2024](#)

Statement: The Title of 680.54(A) was revised to add "Equipment" to be more descriptive and remain concise. Adding the words 'enclosures of panelboards' in 680.54(A)(3) makes the text technically correct.



Public Input No. 2272-NFPA 70-2023 [Section No. 680.54(A)]

(A)– Connection to Equipment Grounding Conductor .

The following equipment shall be connected to an equipment grounding conductor:

- (1) All electrical equipment located within the fountain or within 1.5 m (5 ft) of the inside wall of the fountain, other than listed low-voltage luminaires not requiring grounding
- (2) All electrical equipment associated with the recirculating system of the fountain
- (3) Panelboards that are not part of the service equipment and that supply any electrical equipment associated with the fountain

Statement of Problem and Substantiation for Public Input

Changing the title would make the text technically correct. This requirement is about connecting the equipment grounding conductor of the wire type to electrical equipment, not about grounding. The section title must be revised to match the technical requirement. In accordance with NEC style manual section 2.1.3.2 the title must be descriptive and concise with the intent of the requirement. See 215.6 Feeder Equipment Grounding Conductor, 320.108 Equipment Grounding Conductor, 330.108 Equipment Grounding Conductor, 334.108 Equipment Grounding Conductor, 410.182 Equipment Grounding Conductor, 547.27 Separate Equipment Grounding Conductor, 555.37 Equipment Grounding Conductor, and 690.45 Size of Equipment Grounding Conductors.

Submitter Information Verification

Submitter Full Name: Mike Holt
Organization: Mike Holt Enterprises Inc
Street Address:
City:
State:
Zip:
Submittal Date: Tue Aug 15 15:03:34 EDT 2023
Committee: NEC-P17

Committee Statement

Resolution: [FR-9172-NFPA 70-2024](#)

Statement: The Title of 680.54(A) was revised to add "Equipment" to be more descriptive and remain concise. Adding the words 'enclosures of panelboards' in 680.54(A)(3) makes the text technically correct.



Public Input No. 2273-NFPA 70-2023 [Section No. 680.55]

680.55 ~~Methods of~~ Connection to Equipment Grounding Conductor .

(A) Applied Provisions.

The provisions of 680.7(A), 680.21(A), 680.23(B)(3), 680.23(F)(1) and (F)(2), and 680.24(F) shall apply.

(B) Supplied by a Flexible Cord.

Electrical equipment that is supplied by a flexible cord shall have all exposed non-current-carrying metal parts grounded by an insulated copper equipment grounding conductor that is an integral part of this cord. The equipment grounding conductor shall be connected to an equipment grounding terminal in the supply junction box, transformer enclosure, power supply enclosure, or other enclosure.

Statement of Problem and Substantiation for Public Input

Changing the title would make the text technically correct. This requirement is about methods of connecting the equipment grounding conductor of the wire type, not about grounding. In accordance with NEC style manual section 2.1.3.2 the title must be descriptive and concise with the intent of the requirement.

Submitter Information Verification

Submitter Full Name: Mike Holt

Organization: Mike Holt Enterprises Inc

Street Address:

City:

State:

Zip:

Submittal Date: Tue Aug 15 15:06:14 EDT 2023

Committee: NEC-P17

Committee Statement

Resolution: [FR-9175-NFPA 70-2024](#)

Statement: The Title of 680.55 was revised to remove "Methods of" and add "Equipment" to be more descriptive and remain concise. Item (A) was editorially revised to improve usability.



Public Input No. 1327-NFPA 70-2023 [Section No. 680.56(D)]

(D) Terminations.

Connections with flexible cord shall be permanent, except that grounding-type attachment plugs and receptacles shall be permitted to facilitate removal or disconnection for maintenance, ~~repair~~ servicing, or storage of fixed or stationary equipment not located in any water-containing part of a fountain.

Statement of Problem and Substantiation for Public Input

Servicing is a defined term and includes repairs. Using a defined term adds more clarity and helps avoid confusion between activities that are deemed as servicing and those that are deemed as reconditioning.

Submitter Information Verification

Submitter Full Name: Thomas Domitrovich

Organization: Eaton Corporation

Street Address:

City:

State:

Zip:

Submittal Date: Sat Jul 08 11:45:11 EDT 2023

Committee: NEC-P17

Committee Statement

Resolution: [FR-9178-NFPA 70-2024](#)

Statement: Editorial revisions were made in the title and requirements to clarify that this section applies to any flexible cord-connected equipment, not just those that are cord-and-plug-connected. The terms "maintenance" and "repair" were changed to "servicing" to better incorporate defined terms.



Public Input No. 2467-NFPA 70-2023 [Section No. 680.57(C)(2)]

(2) Portable.

A portable electric sign shall not be placed within a ~~pool~~ fountain or ~~fountain~~ or within 1.5 m (5 ft) measured horizontally from the inside walls of the fountain.

Statement of Problem and Substantiation for Public Input

This PI proposes to remove the reference to a pool. Part V Fountains, per it's scope at 680.50, applies to all permanently installed fountains only. See companion PI 2468 that proposes to relocate the pool specific requirement to 680.29.

Related Public Inputs for This Document

<u>Related Input</u>	<u>Relationship</u>
<u>Public Input No. 2468-NFPA 70-2023 [New Section after 680.28]</u>	

Submitter Information Verification

Submitter Full Name: Vincent Della Croce

Organization:

Street Address:

City:

State:

Zip:

Submittal Date: Thu Aug 17 15:00:20 EDT 2023

Committee: NEC-P17

Committee Statement

Resolution: FR-9134-NFPA 70-2024

Statement: The requirement was revised to remove "pool or" as this is now reflected in new Section 680.29. The requirement now applies only to fountains.



Public Input No. 2443-NFPA 70-2023 [Section No. 680.58]

680.58 Ground-Fault Circuit-Interrupter (GFCI) and Special Purpose Ground-Fault Circuit-Interrupter (SPGFCI) Protection for Adjacent Receptacle Outlets.

All receptacles ~~rated 125 volts through 250 volts~~, 60 amperes or less, located within 6.0 m (20 ft) of a fountain edge shall have GFCI protection complying with 680.5(B) or SPGFCI protection complying with 680.5(C), as applicable.

Statement of Problem and Substantiation for Public Input

Removing 'rated 125 volt through 250 volt' so this requirement would apply to 480V receptacles located within 20 feet of pool water. This enhances electrical safety in these areas where the shock hazard is increased.

Submitter Information Verification

Submitter Full Name: Mike Holt
Organization: Mike Holt Enterprises Inc
Street Address:
City:
State:
Zip:
Submittal Date: Thu Aug 17 12:08:53 EDT 2023
Committee: NEC-P17

Committee Statement

Resolution: [FR-9181-NFPA 70-2024](#)

Statement: This revision reflects the availability of higher-rated GFCI and SPGFCI devices up to 480V that can be applied to all receptacles within 6.0 m of fountain edge, and harmonizes the code with existing provisions, such as 210.8(B). Section 680.58 currently stipulates a 60-ampere threshold for equipment requiring ground-fault circuit interrupter (GFCI) protection. Commercially available three-phase GFCI devices now offer ratings up to 100 amperes. Additionally, 680.58 was separated into a list for improved usability.



Public Input No. 4527-NFPA 70-2023 [Section No. 680.58]

680.58 Ground-Fault Circuit-Interrupter (GFCI) and Special Purpose Ground-Fault Circuit-Interrupter (SPGFCI) Protection for Adjacent Receptacle Outlets.

All receptacles rated 125 volts through 250 volts, 60 amperes or less single-phase, or 100 amperes or less 3-phase, located within 6.0 m (20 ft) of a fountain edge shall have GFCI protection complying with 680.5(B) or SPGFCI protection complying with 680.5(C), as applicable.

Statement of Problem and Substantiation for Public Input

Equipment is now being used that is above the 60 A value currently stated in the code. GFCI/SPGFCI devices are commercially available at the 100 A rating.

Related Public Inputs for This Document

<u>Related Input</u>	<u>Relationship</u>
<u>Public Input No. 4500-NFPA 70-2023 [Section No. 680.5(B)]</u>	

Submitter Information Verification

Submitter Full Name: Mark Pollock
Organization: Littelfuse
Street Address:
City:
State:
Zip:
Submittal Date: Thu Sep 07 17:05:50 EDT 2023
Committee: NEC-P17

Committee Statement

Resolution: FR-9181-NFPA 70-2024

Statement: This revision reflects the availability of higher-rated GFCI and SPGFCI devices up to 480V that can be applied to all receptacles within 6.0 m of fountain edge, and harmonizes the code with existing provisions, such as 210.8(B). Section 680.58 currently stipulates a 60-ampere threshold for equipment requiring ground-fault circuit interrupter (GFCI) protection. Commercially available three-phase GFCI devices now offer ratings up to 100 amperes. Additionally, 680.58 was separated into a list for improved usability.



Public Input No. 2928-NFPA 70-2023 [Section No. 680.60]

680.60 General.

The provisions of Part I and Part VI of this article shall apply to pools and tubs for therapeutic use in health care facilities, gymnasiums, athletic training rooms, and similar areas. Portable therapeutic appliances shall comply with Article 422, Parts II and III- ~~of Article 422~~.

Statement of Problem and Substantiation for Public Input

This Public Input is being submitted on behalf of the NEC Correlating Committee Usability Task Group in order to provide correlation throughout the document. The text is revised to to comply with the NEC Style Manual Section 4.1.4, regarding the use of Parts.

4.1.4 References to an Entire Article. References shall not be made to an entire article, except for the Article 100 or where referenced to provide the necessary context. References to specific parts within articles shall be permitted. References to all parts of an article shall not be permitted. The article number shall precede the part number.

The Usability Task Group members are: Derrick Atkins, David Hittinger, Richard Holub, Dean Hunter, Chad Kennedy and David Williams.

Submitter Information Verification

Submitter Full Name: David Williams

Organization: Delta Charter Township

Street Address:

City:

State:

Zip:

Submittal Date: Mon Aug 28 12:17:19 EDT 2023

Committee: NEC-P17

Committee Statement

Resolution: [FR-9182-NFPA 70-2024](#)

Statement: The text was revised to comply with the NEC Style Manual 4.1.4.



Public Input No. 1656-NFPA 70-2023 [Section No. 680.62(A)(1)]

(1) Listed Units.

If so marked, a listed, labeled, and identified self-contained unit or a listed, labeled, and identified packaged equipment assembly that includes integral ~~ground-fault-circuit-interrupter protection~~ GFCI protection for all electrical parts within the unit or assembly (pumps, air blowers, heaters, lights, controls, sanitizer generators, wiring, and so forth) shall be permitted without additional GFCI protection.

Statement of Problem and Substantiation for Public Input

Section 2.1.2.9 of the NEC Style Manual permits the use of acronyms. The acronym, GFCI, is currently used in Article 100 and Section 680.5.

Submitter Information Verification

Submitter Full Name: Vincent Della Croce

Organization:

Street Address:

City:

State:

Zip:

Submittal Date: Thu Jul 27 16:36:52 EDT 2023

Committee: NEC-P17

Committee Statement

Resolution: [FR-9183-NFPA 70-2024](#)

Statement: Section 2.1.2.9 of the NEC Style Manual permits the use of acronyms. The acronym GFCI is defined in Article 100.



Public Input No. 1657-NFPA 70-2023 [Section No. 680.62(A)(2)]

(2) Other Units.

A therapeutic tub or hydrotherapeutic tank rated 3 phase or rated over 250 volts or with a heater load of more than 50 amperes shall not require the supply to be protected by a ~~ground-fault circuit interrupter~~ GFCI.

Statement of Problem and Substantiation for Public Input

Section 2.1.2.9 of the NEC Style Manual permits the use of acronyms. The acronym, GFCI, is currently used in Article 100 and Section 680.5.

Submitter Information Verification

Submitter Full Name: Vincent Della Croce

Organization:

Street Address:

City:

State:

Zip:

Submittal Date: Thu Jul 27 16:39:15 EDT 2023

Committee: NEC-P17

Committee Statement

Resolution: [FR-9184-NFPA 70-2024](#)

Statement: Section 2.1.2.9 of the NEC Style Manual permits the use of acronyms. The acronym GFCI is defined in Article 100.



Public Input No. 2274-NFPA 70-2023 [Section No. 680.62(D)]

(D)– Equipment Grounding Conductor .

The following fixed or stationary equipment shall be connected to the equipment grounding conductor:

- (1) All electrical equipment located within 1.5 m (5 ft) of the inside wall of the tub
- (2) All electrical equipment associated with the circulating system of the tub

Statement of Problem and Substantiation for Public Input

Changing the title would make the text technically correct. This requirement is about connecting the equipment grounding conductor of the wire type to electrical equipment, not about grounding. In accordance with NEC style manual section 2.1.3.2 the title must be descriptive and concise with the intent of the requirement.

Submitter Information Verification

Submitter Full Name: Mike Holt

Organization: Mike Holt Enterprises Inc

Street Address:

City:

State:

Zip:

Submittal Date: Tue Aug 15 15:08:45 EDT 2023

Committee: NEC-P17

Committee Statement

Resolution: [FR-9186-NFPA 70-2024](#)

Statement: The Title of 680.62(D) was revised to add "Equipment" to be more descriptive and remain concise.



Public Input No. 2392-NFPA 70-2023 [Section No. 680.71]

680.71– 71 GFCI Protection.

Hydromassage bathtubs and their associated electrical components shall be on an individual branch circuit(s) and protected by a readily accessible GFCI. All 125-volt, single-phase receptacles not exceeding 30 amperes and located within 1.83 m (6 ft) measured horizontally of the inside walls of a hydromassage tub shall be GFCI protected.

Statement of Problem and Substantiation for Public Input

The section title 'Protection' is very vague and uninformative, proposing to change to 'GFCI Protection' to give Code users the information about the requirement. In accordance with NFPA Style Manual section 2.1.3.2 the title must be descriptive and concise with the intent of the requirement.

Submitter Information Verification

Submitter Full Name: Mike Holt
Organization: Mike Holt Enterprises Inc
Street Address:
City:
State:
Zip:
Submittal Date: Wed Aug 16 16:28:34 EDT 2023
Committee: NEC-P17

Committee Statement

Resolution: [FR-9190-NFPA 70-2024](#)

Statement: Section 680.71 was split into two separate sections, with 680.71 covering the requirement for an individual branch circuit and a new section 680.75 covering GFCI protection. New Section 680.75 was split into two subsections for clarity and ease of reading. These editorial revisions are non-technical in nature and are intended to satisfy section 3.5.1.2 of the NEC Style Manual.



Public Input No. 2393-NFPA 70-2023 [Section No. 680.71]

680.71 Protection.

(A) Branch-Circuit. Hydromassage bathtubs and their associated electrical components shall be on an individual branch circuit(s) and protected by a readily accessible GFCI.

(B) Receptacles. All 125-volt, single-phase receptacles not exceeding 30 amperes and located within 1.83 m (6 ft) measured horizontally of the inside walls of a hydromassage tub shall be GFCI protected.

Statement of Problem and Substantiation for Public Input

Breaking section into a list item format to bring clarity for Code users. In accordance with NFPA Style Manual section 3.5.1.2 additional subdivisions shall be used where multiple requirements can be broken into independent requirements.

Submitter Information Verification

Submitter Full Name: Mike Holt
Organization: Mike Holt Enterprises Inc
Street Address:
City:
State:
Zip:
Submittal Date: Wed Aug 16 16:29:36 EDT 2023
Committee: NEC-P17

Committee Statement

Resolution: [FR-9190-NFPA 70-2024](#)

Statement: Section 680.71 was split into two separate sections, with 680.71 covering the requirement for an individual branch circuit and a new section 680.75 covering GFCI protection. New Section 680.75 was split into two subsections for clarity and ease of reading. These editorial revisions are non-technical in nature and are intended to satisfy section 3.5.1.2 of the NEC Style Manual.



Public Input No. 2085-NFPA 70-2023 [Section No. 680.74(B)]

(B) Bonding Conductor.

All metal parts required to be bonded by this section shall be bonded together using a solid copper bonding jumper, insulated, covered, or bare, not smaller than 8 AWG. The bonding jumper(s) shall be required for equipotential bonding in the area of the hydromassage bathtub and shall not be required to be extended or attached to any remote enclosed panelboard, service equipment, or any electrode. In all installations a bonding jumper long enough to terminate on a replacement non-double-insulated pump or blower motor shall be provided and shall be terminated to the equipment grounding conductor of the branch circuit of the motor when a double-insulated circulating pump or blower motor is used.

Statement of Problem and Substantiation for Public Input

The term 'panelboard' and 'enclosed panelboard' are defined terms. Adding the word 'enclosed panelboard' makes the text technically correct. Note: The term 'Enclosed Panelboard' was added to NEC Article 100 during the 2023 Code cycle.

Submitter Information Verification

Submitter Full Name: Mike Holt

Organization: Mike Holt Enterprises Inc

Street Address:

City:

State:

Zip:

Submittal Date: Fri Aug 11 15:38:12 EDT 2023

Committee: NEC-P17

Committee Statement

Resolution: [FR-9192-NFPA 70-2024](#)

Statement: Adding the word 'enclosures' makes the text technically correct.



Public Input No. 2086-NFPA 70-2023 [Section No. 680.83]

680.83 Equipotential Bonding.

Lifts shall be bonded in accordance with 680.26(B)(5) and (B)(7) using solid copper conductors, insulated, covered, or bare, not smaller than 8 AWG. Connections to bonded parts shall be made in accordance with 250.8. An 8 AWG or larger solid copper bonding conductor provided to reduce voltage gradients in the pool lift area shall not be required to be extended or attached to remote enclosed panelboards, service equipment, or electrodes.

Statement of Problem and Substantiation for Public Input

The term 'panelboard' and 'enclosed panelboard' are defined terms. Adding the word 'enclosed panelboard' makes the text technically correct. Note: The term 'Enclosed Panelboard' was added to NEC Article 100 during the 2023 Code cycle.

Submitter Information Verification

Submitter Full Name: Mike Holt

Organization: Mike Holt Enterprises Inc

Street Address:

City:

State:

Zip:

Submittal Date: Fri Aug 11 15:39:13 EDT 2023

Committee: NEC-P17

Committee Statement

Resolution: [FR-9194-NFPA 70-2024](#)

Statement: Adding the word 'enclosures' makes the text technically correct.



Public Input No. 3710-NFPA 70-2023 [Part II.]

Part II. Permanently Installed Pools, Semi-Permanently Installed Pools

Statement of Problem and Substantiation for Public Input

Added the pool type "Semi-Permanently Installed Pools" to ensure this pool type is installed per part II of section 680. Because of the current definitions of Permanent and storable pools a class of above ground pools has been left out. This pool type is not meant to be stored when not in use or over the winter.

Related Public Inputs for This Document

<u>Related Input</u>	<u>Relationship</u>
Public Input No. 3681-NFPA 70-2023 [New Definition after Definition: Pool, Permanently Installe...]	title change to incorporate new definition
Public Input No. 3695-NFPA 70-2023 [Definition: Pool, Permanently Installed Swimming, Wading, L...]	revised definition to support new definition
Public Input No. 3700-NFPA 70-2023 [Definition: Pool, Storable; used for Swimming, Wading, or L...]	revised definition to support new definition
Public Input No. 3719-NFPA 70-2023 [Section No. 680.20]	

Submitter Information Verification

Submitter Full Name: Ronald Dalrymple
Organization: City of Schertz Texas
Street Address:
City:
State:
Zip:
Submittal Date: Tue Sep 05 14:33:01 EDT 2023
Committee: NEC-P17

Committee Statement

Resolution: The submitter's objectives have been addressed by the revisions of the definitions of permanently installed pools and storable pools. The type of pool suggested in the public input is now considered to be a storable pool unless a permanent deck is installed around all or part of the pool.



Public Input No. 293-NFPA 70-2023 [Part V.]

Part V. Fountains and Splash Pads

Statement of Problem and Substantiation for Public Input

Requirements for splash pads are challenging enough for NEC® users to locate; don't complicate that by omitting them from the Article 680 Part V title. Splash pads have no appreciable depth and cannot be used for swimming, wading or immersion as is the case for pools and spas. Since the explicit requirements 680.50(A)(2) and 680.54(C) already reside in Part V of Article 680, revise Part V's title to be more inclusive. Heck, CMP-17 can even throw a Splash Pad Pride Parade!

Submitter Information Verification

Submitter Full Name: Brian Rock
Organization: Hubbell Incorporated
Street Address:
City:
State:
Zip:
Submittal Date: Tue Feb 07 17:58:25 EST 2023
Committee: NEC-P17

Committee Statement

Resolution: The term "splash pads" was not added to the text in 680.50, nor added to the Title of Part V, as the definition of Fountain already includes Splash Pads, and the definition of Splash Pad indicates that a Splash pad is a fountain.