



Public Comment No. 1655-NFPA 70-2024 [Global Input]

This Global Public Comment is for CMP-15 to review the use of the terms “overcurrent”, “overcurrent protective devices” and “overcurrent protection”.

Additional Proposed Changes

<u>File Name</u>	<u>Description</u>	<u>Approved</u>
CMP-15_OCPD_TG-4_CMP-10.pdf	CMP-15_OCPD_TG-4 CMP-10	
All_CMP_Comments_Files_from_CMP-10_TG-4.pdf	All CMP Comments Files from CMP-10 TG-4	

Statement of Problem and Substantiation for Public Comment

This Public Comment is submitted on behalf of a Task Group formed under the purview of Code Making Panel 10 consisting of Randy Dollar, Thomas Domitrovich, Jason Doty, Diane Lynch, Alan Manche, Nathan Philips, David Williams, and Danish Zia. This Public Comment, along with other Public Comments, was developed with the goal of improving usability and accuracy on requirements associated with overcurrent protective devices.

The Task Group reviewed all instances of the term “overcurrent”, “overcurrent protective devices” and “overcurrent protection” and provided recommended changes to align proposed and current defined terms.

For consistency, the task group chose to use the full defined term “overcurrent protective device” in the title of all sections or subdivisions and the acronym “OCPD” or “OCPDs” when used in the body of each code section.

The term overcurrent protection applies to the application of an overcurrent protective device OCPD, to protect conductors and equipment.

Two documents are attached: One for your specific code panel and the other is a comprehensive document illustrating all of the code-wide comments made by this task group.

The current term “Overcurrent Protective Device, Branch-Circuit” is being deleted and the new defined term “Overcurrent Protective Device (OCPD)” will be used instead.

The following are the proposed terms being submitted to CMP-10.

PC 1639 Overcurrent Protection.
Automatic interruption of an overcurrent

PC 1636 Overcurrent Protective Device (OCPD).
A device capable of providing protection over the full range of overcurrent between its rated current and its interrupting rating. (CMP-10)

Informational Note 1: Prior editions of NFPA 70 included the defined term “branch circuit overcurrent protective device” for overcurrent protective devices suitable for providing protection for service, feeder and branch circuits. This term has been revised to a generalized term of “overcurrent protective device” (OCPD). The specific requirements using this term may include modifiers (such as branch OCPD, feeder OCPD, service OCPD) to specify location or application of the OCPD, or to specify variations (such as supplementary OCPD).

Informational Note 2: See 240.7 for a list of overcurrent protective devices suitable for providing protection for service, feeder, branch circuits and equipment.

Related Item

- Global PI 4050 • PC 1636
- PC 1639

Submitter Information Verification

Submitter Full Name: David Williams

Organization: Delta Charter Township

Street Address:

City:

State:

Zip:

Submittal Date: Sun Aug 25 21:54:51 EDT 2024

Committee: NEC-P15

CMP-10 TG-4 Review of Overcurrent Language for the Articles under the purview of CMP-15

CMP	NEC Section (using First Draft of 2026 NEC)	Current Language	"New" Language
15	Article 100		
	Bull Switch	Overcurrent protection	Fine as is
15	Article 517		
	517.17(B)	Overcurrent protective devices	OCPDs
	517.31(G). (X5)	Overcurrent protective devices	OCPDs
	517.31(G)	Overcurrent	Fine as is
	517.33((C). (X5)	Overcurrent protective devices	OCPDs
	517.42(F)	Overcurrent protective devices	OCPDs
	517.42(F)	Overcurrent	Fine as is
	517.73	Overcurrent Protection	Fine as is
	517.73(A)	Overcurrent protective devices	OCPDs
	517.73(B)	Overcurrent protective devices	OCPDs
	517.73(B)	Overcurrent Protection	Fine as is
	517.74(B)	Overcurrent protective devices	OCPDs
	517.160(A)(2)	Overcurrent Protection	Fine as is
	517.160(A)(2)	Overcurrent protective device	OCPD
	517.160(A)(2)	be protected against Overcurrent	be provided with overcurrent protection
	517.160(A)(3)	Overcurrent protective devices	OCPDs
	517.160(B)(1)	Overcurrent protective devices	OCPDs
15	Article 518		
	518.7(A)(1)	Overcurrent Protection	Fine as is
	518.17(A)(1) and (2)	Overcurrent Devices	OCPDs
15	Article 520		
	520.9	Branch Circuit Overcurrent Device	OCPD
	520.21	Overcurrent protective devices	OCPDs
	520.25. (X3)	Overcurrent Protection	Fine as is
	520.26	Overcurrent protective devices	OCPD
	520.26. (X3)	Overcurrent Protection	Fine as is
	520.27. (X2)	Overcurrent Device	OCPD
	520.44-T	Overcurrent Devices	OCPD
	520.50(C)	Overcurrent Protection	Fine as is
	520.50.	Branch-circuit overcurrent protective device	OCPDs
	520.52	Overcurrent Protection	Fine as is

	520.53(A)	Overcurrent protective devices	OCPDs
	520.53(D)	Overcurrent Protection	Fine as is
	520.54	Overcurrent Devices	OCPDs
	520.54(D)	Overcurrent Device	OCPD
	520.54(D)(1) and (2)	Overcurrent protective devices	OCPD
	520.54(E)	Overcurrent protective device	OCPD
	520.54(E). (X4)	Overcurrent protection device	OCPD
	520.54(E)	Overcurrent Devices	OCPDs
	520.54(K)	Overcurrent Device	OCPD
	520.68	Overcurrent protective device	OCPD
	520.68(3)	Overcurrent Device	OCPD
	520.68(4)	Overcurrent protective device	OCPD
	520.68(6)	Overcurrent Devices	OCPDs
	520.68(C)	Overcurrent Protection	Fine as is
15	Article 522		
	522.10(A)(2). (X3)	Overcurrent Devices	OCPDs
	522.10(A)(2)	Overcurrent protective device	OCPD
	522.10(B). (X4)	Overcurrent Devices	OCPDs
	522.23. (X3)	Overcurrent Protection	Fine as is
15	Article 525		
	525.12	Overcurrent Device	OCPD
	525.23(B)	Overcurrent Device	OCPD
	525.23(C). (X2)	Overcurrent Protection	Fine as is
15	Article 530		
	530.9(A)	Branch-circuit overcurrent device	Branch-circuit OCPD
	530.10(C)	Overcurrent Protection	Fine as is
	530.23 and (A)	Overcurrent Protection	Fine as is
	530.23(B)	Overcurrent protective devices	OCPDs
	530.23(D)	Overcurrent Protection	Fine as is
	530.42	Overcurrent Protection	Fine as is
15	Article 540		
	540.11(B)	Overcurrent Devices	OCPDs

CMP-10 TG-4 Review of Overcurrent Language for the Articles under the purview of CMP-1

CMP	NEC Section (using First Draft of 2026 NEC)	Current Language	"New" Language
1	Article 110		
	110.10.	overcurrent protective devices	OCPDs
	110.10.	circuit protective devices	Fine as is
	110.26(C)(2)	overcurrent devices	OCPD
	110.26(C)(3)	overcurrent devices	OCPD
	110.52	Overcurrent protection	Fine as is
	110.52	Overcurrent	Motor-operated Equipment shall be provided with overcurrent protection
	110.52	Overcurrent	Transformers shall be provided with overcurrent protection

CMP-10 TG-4 Review of Overcurrent Language for the Articles under the purview of CMP-2

CMP	NEC Section (using First Draft of 2026 NEC)	Current Language	"New" Language
2	Article 100		
	Branch Circuit (Branch-Circuit)	overcurrent device	overcurrent protective device (OCPD)
2	Article 120		
	120.5(E)	overcurrent device	OCPD
	120.7(B)	overcurrent protective device	OCPD
	120.87(3)	Overcurrent protection	Fine as is
2	Article 210		
	210.4(A)	branch-circuit overcurrent protective device, OCPD	Fine as is
	210.4(C)	branch-circuit OCPD	Fine as is
	210.11(B)	branch-circuit OCPD	Fine as is
	210.12(A)	branch-circuit OCPD (X-8)	Fine as is
	210.18	overcurrent device OCPD (X-2)	Fine as is
	210.19(A)(1)EX	branch-circuit OCPD	Fine as is
	210.20.	Overcurrent protection	Fine as is
	210.20.	branch-circuit OCPD	Fine as is
	210.20(A)	branch-circuit OCPD	Fine as is
	210.20(C)	branch-circuit OCPD	Fine as is
	T-210.24	Overcurrent protection	Fine as is
2	Annex D		
		Overcurrent Protection	CMP-2 To review references to OCPD and the revised terms.
	D3. (X2)		
	D3a. (X8)	Branch-Circuit OCPD	CMP-2 to Review
	D3a.	Overcurrent Protection	CMP-2 to Review
	D3a. (X2)	Branch-Circuit OCPD	CMP-2 to Review

CMP-10 TG-4 Review of Overcurrent Language for the Articles under the purview of CMP-3

CMP	NEC Section (using First Draft of 2026 NEC)	Current Language	"New" Language
3	Article 100		
	Fault Managed Power.	Overcurrent protection	Fine as is
	Fire Alarm Circuit	Overcurrent device	overcurrent protective device (OCPD)
3	Article 300		
	300.5-T	Overcurrent Protection	Fine as is
	300.17(l)	Overcurrent Device	OCPD
	300.28(C)(3). (X5)	Overcurrent Protection	Fine as is
3	Article 590		
	590.6(A)	Overcurrent Protection	Fine as is
	590.6(B)	be protected from Overcurrent	shall be provided with overcurrent protection
	590.9. Title	Overcurrent protective device	Fine as is
	590.9(A)	Overcurrent protective devices	OCPDs
	590.9(B) Title	Service Overcurrent protective devices	Fine as is
	590.9(B)	Overcurrent protective devices	OCPDs
3	Article 721		
	721.50(A)	Overcurrent	Fine as is
3	Article 722		
	722.1	Overcurrent Protection	Fine as is
3	Article 724	Class 1	
	724.40(B). (X3)	Overcurrent Devices	OCPDs
	724.40(B). (X2)	Overcurrent Device	OCPD
	724.40(B). (X2)	Overcurrent Protection	Fine as is
	724.43. (X4)	Overcurrent Protection	Fine as is
	724.45	Overcurrent Device	OCPD
	724.45. (X3)	Overcurrent Devices	OCPDs
	724.45(A)	Overcurrent Devices	OCPDs
	724.45(B)	Overcurrent Protection	Fine as is
	724.45(B)	Overcurrent Device	OCPD
	724.45(C). (X2)	Overcurrent protective devices	OCPDs
	724.45(D)	Overcurrent Protection	Fine as is
	724.45(E)	Overcurrent Protection	Fine as is
3	Article 725		
	725.1 In	Overcurrent Protection	Fine as is

	725.127	Overcurrent Device	OCPD
3	Article 760		
	760.41(B)	Overcurrent protective device	OCPD
	760.41(B)	Overcurrent protection devices	OCPDs
	760.43. (X3)	Overcurrent Protection	Fine as is
	760.45. Title	Overcurrent device	Overcurrent protective device
	760.45	Overcurrent protection devices	OCPDs
	760.45 Ex 1 & 2	Overcurrent Protection	Fine as is
	760.121(B)	Branch-Circuit Overcurrent protective device	OCPD
	760.121(B)	Overcurrent protection devices	OCPDs
	760.127	Overcurrent Protection	Fine as is
	760.127	Overcurrent Device	OCPD
3	Article 794		
	794.1	Overcurrent Protection	Fine as is

CMP-10 TG-4 Review of Overcurrent Language for the Articles under the purview of CMP-4

CMP	NEC Section (using First Draft of 2026 NEC)	Current Language	"New" Language
4	Article 690		
	690.2	PV dc Overcurrent protective devices	PV dc OCPDs
	690.8	Overcurrent Device	OCPD and OCPDs
	690.9. Title	Overcurrent Protection	Fine as is
	690.9(A). (X2)	be protected from Overcurrent	shall be provided with overcurrent protection
	690.9(A)(1). Title	Overcurrent Protection	Fine as is
	690.9(A)(1).	Overcurrent protective devices	OCPDs
	690.9(A)(2). Title	Overcurrent Protection	Fine as is
	690.9(A) (2)	be protected from Overcurrent	shall be provided with overcurrent protection
	690.9(A) (2) In	Overcurrent protection	Fine as is
	690.9(A) (2) In	Overcurrent device	OCPD
	690.9(A)(3)	Overcurrent	Fine as is
	690.9(B)	shall be permitted to prevent overcurrent of conductors	Fine as is
	690.9(B)	Overcurrent device	OCPD and OCPDs
	690.9(C)	Overcurrent protective device and Devices	OCPD and OCPDs
	690.31(E)	Overcurrent protective devices	OCPDs
	690.45	Overcurrent protective device	OCPD
	690.45	Overcurrent Device	OCPD
4	Article 692		
	692.8. Title	Overcurrent Device	Overcurrent Protective Devices
	692.8	Overcurrent protective device	OCPDs
	692.9	Overcurrent Protection	Fine as is
	692.9	Overcurrent Devices	OCPDs
4	Article 694		
	694.7(D)	Overcurrent Device	OCPD
	694.12(B). Title	Overcurrent Device	Overcurrent Protective Device
	694.12(B)(2). Title	Overcurrent Devices	Overcurrent Protective Devices
	694.12(B)(2)	Overcurrent Devices	OCPDs
	694.15	Overcurrent Protection	Fine as is
	694.15	Overcurrent Devices	OCPDs
	694.15 In	Overcurrent Protection	Fine as is
	694.15(B)(1)	Overcurrent Protection	Fine as is
	694.15(C)	Overcurrent Devices	OCPDs

4	Article 705		
	705.11(C). Title	Overcurrent Protection	Fine as is
	705.11(C)	be protected from overcurrent	have overcurrent protection
	705.11(C)(1). (1) (2) (3)	Overcurrent protective device	OCPD
	705.11(C)(2)	Overcurrent protection devices	OCPDs
	705.12(A)(2). (X4)	Overcurrent Device	OCPD
	705.12(A)(3)	Overcurrent Devices	OCPDs
	705.12(B)	(Multiple) Overcurrent Device and (s)	OCPD. And OCPDs
	705.12(B)	(Warning labels) Overcurrent Device and (s)	Overcurrent Protective Device and Devices
	705.28(B)Ex.1	Overcurrent Devices	OCPDs
	705.28(B)Ex.3	Overcurrent Device	OCPD
	705.30. Title	Overcurrent Protection	Fine as is
	705.30(A). (X2)	Overcurrent Protection	Fine as is
	705.30(A)	Overcurrent Devices	OCPDs
	705.30.(C)	Overcurrent Devices	OCPDs
	705.30.(F)	Overcurrent Protection	Fine as is
	705.70.	Overcurrent Devices	OCPDs
	705.70.	Overcurrent Protection	Fine as is

CMP-10 TG-4 Review of Overcurrent Language for the Articles under the purview of CMP-5

CMP	NEC Section (using First Draft of 2026 NEC)	Current Language	"New" Language
5	Article 100		
	Ground-Fault Current Path, Effective	overcurrent protective device	overcurrent protective device (OCPD)
	Ground-Fault Protection of Equipment	overcurrent device	overcurrent protective device (OCPD)
5	Article 200		
	200.10(E)	overcurrent device	OCPD
5	Article 250		
	250.4(A)(5). Title	Overcurrent protective Device	Fine as is
	250.4(A)(5)	Overcurrent Device	OCPD
	250.4(B)(4)	Overcurrent Devices	OCPDs
	250.30(A)(1)	Overcurrent Device	OCPD
	250.30(A)(1)	Overcurrent Devices	OCPDs
	250.32(B)(2). (X4)	Overcurrent Protection	Fine as is
	250.32(C)(2). (X4)	Overcurrent Protection	Fine as is
	250.35(B)	Overcurrent Protection	Fine as is
	250.36(D)	Overcurrent Device	Fine as is
	250.36(E)(1)	Overcurrent Device	OCPD
	250.102(B)(2)	Overcurrent Protection	Fine as is
	250.102(D). (X3)	Overcurrent Devices	OCPDs
	250.118(A)(5)	Overcurrent Devices	OCPDs
	250.118(A)(6)	Overcurrent Devices	OCPDs
	250.118(A)(7)	Overcurrent Devices	OCPDs
	250.122(C)	Overcurrent Device	OCPD
	250.122(F)(1). (X3)	Overcurrent protective device	OCPD
	250.122(G)	Overcurrent Device	OCPD
	250.142. (X2)	Overcurrent Device	OCPD
	250.148	Overcurrent Device	OCPD
	250.164	Overcurrent Device	OCPD
	250.166	Overcurrent Protection	Fine as is
	250.169	Overcurrent Devices	OCPD
5	Article 270		
	270.4(A)(5)	Overcurrent Device	OCPD
	270.4(B)(4)	Overcurrent Devices	OCPDs
	270.30(A)(1)	Overcurrent Devices	OCPDs

	270.32(B)(2). (X4)	Overcurrent Protection	Fine as is
	270.32(C)(2). (X4)	Overcurrent Protection	Fine as is
	270.35(B)	Overcurrent Protection	Fine as is
	270.35(B)	Overcurrent protective device	OCPD
	270.36(D)	Overcurrent Device	OCPD
	270.36(E)	Overcurrent Devices	OCPDs
	270.102(C)(2)	Overcurrent Protection	Fine as is
	270.102(D)	Overcurrent Device	OCPDs
	270.114(C)(3)	Overcurrent setting	CMP to review Language based on new terms
	270.118	Overcurrent Devices	OCPDs
	270.142	Overcurrent Devices	OCPDs
	270.148(B)	Overcurrent Device	OCPD
	270.164(B)	Overcurrent Device	OCPD
	270.166(A)	Overcurrent Protection	Fine as is
	270.169	Overcurrent Devices	OCPDs

CMP-10 TG-4 Review of Overcurrent Language for the Articles under the purview of CMP-6			
CMP	NEC Section (using First Draft of 2026 NEC)	Current Language	"New" Language
6	Article 310		
	310.10(G).	Overcurrent Protection	Fine as is
	310.15(A)	Overcurrent Protection	Fine as is
	310.16-T	Overcurrent Protection	Fine as is
	310.17-T	Overcurrent Protection	Fine as is
6	Article 335		
	335.90.	Overcurrent Protection	Fine as is
6	Article 382		
	382.4	Supplementary Overcurrent Protection	Supplementary Overcurrent Protective Device
6	Article 400		
	400.16	Overcurrent Protection	Fine as is
	400.16	protected against Overcurrent	shall be provided with overcurrent protection
6	Article 402		
	402.14 (X2)	Overcurrent Protection	Fine as is

CMP-10 TG-4 Review of Overcurrent Language for the Articles under the purview of CMP-7

CMP	NEC Section (using First Draft of 2026 NEC)	Current Language	"New" Language
7	Article 100		
	Service Equipment, Mobile Home	overcurrent protective devices	overcurrent protective devices (OCPDs)
7	Article 545		
	545.24	Branch-circuit overcurrent protective device	Branch-circuit OCPD
	545.24(B) Title	Branch Circuit Overcurrent Protection Device	Overcurrent protective devices
	545.24(B)	a Branch Circuit Overcurrent Protective Device	an OCPD
7	Article 547		
	547.41(A)(6). (X2)	Overcurrent Protection	Fine as is
	547.41(B)	Overcurrent Protection	Fine as is
	547.42	Overcurrent Protection	Fine as is
7	Article 550		
	550.11(B). Title	Branch-Circuit protective equipment	Branch-Circuit Overcurrent Protection
	550.11(B)	Overcurrent Protection	Fine as is
	550.11(B)	Branch-Circuit Overcurrent Devices	OCPDs
	550.11(B)	Overcurrent protection size	OCPD rating
	550.15(E)	Branch-circuit overcurrent protective device	OCPD
	550.32	Overcurrent Protection	Fine as is
7	Article 551		
	551.31(A)	Overcurrent protective device	OCPD
	551.31(C)	Overcurrent protective device	OCPD
	551.31(D)	Overcurrent Protection	Fine as is
	551.42	Overcurrent Protection	Fine as is
	551.43. Title	Branch-Circuit protection	Branch-Circuit Overcurrent Protection
	551.43(A)	Branch Circuit Overcurrent Devices	Branch-Circuit OCPDs
	551.43(A)(3)	Overcurrent Protection	Fine as is
	551.45(C)	Overcurrent protective device	OCPD
	551.47(Q)	Overcurrent protective device	OCPD
	551.47(R)	Overcurrent Protection	Fine as is
	551.47(S)	Overcurrent Protection	Fine as is
	551.74	Overcurrent Protection	Fine as is
7	Article 552		
	552.10.(E) Title	Overcurrent Protection	Fine as is
	552.10(E)(1)	Overcurrent protective devices	OCPDs

	T-552.10(E)(1)	Overcurrent Protection	Fine as is
	552.10(E)(4). (X2)	Overcurrent protective device	OCPD
	552.42(A)	Branch Circuit Overcurrent Devices	OCPDs
	552.42(A)	Overcurrent Protection	Fine as is
	552.45(C)	Overcurrent protective device	OCPD
	552.46(A) IN	Overcurrent Protection	Fine as is
	552.47(P)	Overcurrent protective device	OCPD
	552.47(Q)	Overcurrent Protection	Fine as is
7	Article 555		
	555.53	Overcurrent protective device	OCPD
7	Article 675		
	675.6	Branch Circuit Overcurrent Protective Device	OCPD
	675.7	Branch Circuit Overcurrent Protective Devices	OCPDs
	675.8	Overcurrent Protection	Fine as is
7	Article 682		
	682.15(B)	Feeder Overcurrent protective device	Feeder OCPD

CMP-10 TG-4 Review of Overcurrent Language for the Articles under the purview of CMP-8			
CMP	NEC Section (using First Draft of 2026 NEC)	Current Language	"New" Language
8	Article 312		
	312.11. Title	Overcurrent Devices	Overcurrent Protective Device
	312.11	Overcurrent Devices	OCPDs
	312.11(A). (X3)	Overcurrent Device	OCPDs
	312.11(B)	Overcurrent Devices	OCPDs
	312.11(B)(1)	Overcurrent Device	OCPD
8	Article 366		
	366.12	Overcurrent Devices	OCPDs
	366.56(D)	Overcurrent Protection	Fine as is
8	Article 368		
	368.17(A). Title	Overcurrent Protection	Fine as is
	368.17	Overcurrent Protection	Fine as is
	368.17(A)	Protected against Overcurrent	shall be provided with overcurrent protection
	368.17(B). (X2)	Overcurrent Protection	Fine as is
	368.17(B)	Overcurrent Device	OCPD
	368.17(C)	Overcurrent Devices	OCPDs
	368.17(C)Ex.2	Branch-Circuit Overcurrent Device	Branch-Circuit OCPD
	368.17(C)Ex.3	Overcurrent Device	OCPD
	368.17(C)Ex.4	Branch-Circuit overcurrent plug-in device	CMP to review Language based on new terms
	368.17(D). Title	Overcurrent Protection	Fine as is
	368.17(D)	Protected against Overcurrent	shall be provided with overcurrent protection
8	Article 370		
	370.23. Title	Overcurrent Protection	Fine as is
	370.23	Protected against Overcurrent	shall be provided with overcurrent protection
8	Article 371		
	371.17. Title	Overcurrent Protection	Fine as is
	371.17	Overcurrent Protection	Fine as is
	371.17 (A)-(C). Titles	Overcurrent Protection	Fine as is
	371.17(A)-(C)	Protected against Overcurrent	shall be provided with overcurrent protection
	371.17(D)	Protected against Overcurrent	shall be provided with overcurrent protection
	371.17(F)	Overcurrent	shall be provided with overcurrent protection
	371.17(G)	Overcurrent Protection	
	371.17(G)Ex	Overcurrent Protection	Fine as is
	371.17(G)Ex	Overcurrent Device	OCPD

CMP-10 TG-4 Review of Overcurrent Language for the Articles under the purview of CMP-9

CMP	NEC Section (using First Draft of 2026 NEC)	Current Language	"New" Language
9	Article 265		
	265.18	Overcurrent Device	OCPD
	265.20.	Overcurrent Protection	Fine as is
	265.20.	Overcurrent protective devices	OCPDs
	265.20.	Overcurrent Devices	OCPDs
9	Article 266		
	266.1	Overcurrent Protection	Fine as is
	266.5	Overcurrent Protection	Fine as is
	266.5	Protected against overcurrent	shall be provided with overcurrent protection
	266.5	Overcurrent Device	OCPD
9	Article 268		
	268.2. (X2)	Overcurrent Protection	Fine as is
	268.70(F)	Overcurrent Devices	OCPDs
	268.82. (X4)	Overcurrent Protection	Fine as is
	Art. 268 Part VII	Overcurrent Protection	Fine as is
	268.90.	Overcurrent Device	OCPD
	268.90.	Overcurrent Devices	OCPDs
	268.91	Overcurrent Device	OCPD
	268.92	Overcurrent Devices	OCPDs
	268.93	Overcurrent Device	OCPD
9	Article 450		
	450.5 (previously 450.3). (X3)	overcurrent protection	Fine As Is
	450.5(A) and Table. (X3)	overcurrent protection	Fine As Is
	Table 450.5(A) Footnote 2. (X4)	overcurrent device	OCPD
	450.5(B)	overcurrent protection	Fine As Is
	Table 450.5(B) and Table (X2)	overcurrent protection	OCPD
	Table 450.5(B) Footnote 2. (X3)	overcurrent device	OCPD
	Table 450.5(B) Footnote 3	overcurrent protection	OCPD
	450.6(A) Title	overcurrent protection	Fine As Is
	450.6(A) (X3)	overcurrent device	OCPD
	450.6(A) Exception	overcurrent device	OCPD
	450.7(A)(1). (X2)	overcurrent protection	OCPD
	450.7(A)(2). Title	overcurrent protection	Fine As Is

		overcurrent sensing device	Fine As Is
	450.7(A)(2)	overcurrent protection	OCPD
		overcurrent device	OCPD
		branch or feeder protective devices	branch or feeder OCPDs
	450.7(A)(3)	overcurrent device	OCPD
	450.7(B)(2)	overcurrent protection	Fine As Is
	450.7(B)(2)(a)	overcurrent protective device	OCPD
	450.7(B)(2)(b)	overcurrent protection	OCPD
	450.7(B)(2)(b)	overcurrents	Fine As Is
	450.7(B)(2)(b) Exception	overcurrent device	OCPD
	450.8(A). (X2)	overcurrent protection	Fine As Is
	450.8(A)(1)	overcurrent protection	Fine As Is
	450.8(A)(2)	overcurrent protection	Fine As Is
	450.8(A)(3)	protective device	OCPD
	450.8(A)(4)(a)	protective device	OCPD
	450.8(B). Title	Overcurrent Protection	Fine As Is
	450.8(B)	overcurrent device	OCPD
	450.9	overcurrent protection	Fine As Is
	450.9	protective devices (2x)	OCPDs
	450.23(A)(1)(d) Informational Note	overcurrent protection	OCPD
	450.23(B)(1) Informational Note 2	overcurrent protection	OCPD
9	Article 495		
	495.62. Title	Overcurrent Protection	Fine As Is
	495.72	Overcurrent Relay	Fine As Is

CMP-10 TG-4 Review of Overcurrent Language for the Articles under the purview of CMP-10			
CMP	NEC Section (using First Draft of 2026 NEC)	Current Language	"New" Language
10	Article 100		
	Circuit Breaker	Overcurrent	Fine as is
	Coordination, Selective. (Selective Coordination)	Overcurrent condition	Fine as is
	Coordination, Selective. (Selective Coordination)	overcurrent protective devices	overcurrent protective devices (OCPDs)
	Coordination, Selective. (Selective Coordination)	overcurrents	Fine as is
	Coordination, Selective. (Selective Coordination)	overcurrent protective device	overcurrent protective device (OCPD)
	Current Limiting (as applied to overcurrent protection devices)	overcurrent protection devices	overcurrent protective devices (OCPDs)
	Feeder	final branch-circuit overcurrent protective device	overcurrent protective device (OCPD)
	Fuse	overcurrent protective device	overcurrent protective device (OCPD)
	Fuse	overcurrent	Fine as is
	Fuse, Electronically Actuated	overcurrent protective device	overcurrent protective device (OCPD)
	Fuse, Electronically Actuated	overcurrent	Fine as is
	Overcurrent	Overcurrent protection	Fine as is
	Overcurrent Protective Device, Branch-Circuit	Revise with the term Overcurrent Protective Device. (OCPD)	
	Overcurrent Protective Device, Supplementary (need to Revise term with acronym)	overcurrent protective device	overcurrent protective device (OCPD)
	Panelboard	overcurrent devices	overcurrent protective devices (OCPDs)
	Surge-Protective Device (SPD). (X2)	overcurrent device. (X2)	overcurrent protective device (OCPD)
	Switchboard	overcurrent	overcurrent protective devices (OCPDs)
	Tap Conductor	Overcurrent protection	Fine as is
10	Article 215		
	215.1	Overcurrent protection	Fine as is
	215.4(A)(1)Ex.1	overcurrent devices protecting the feeders	feeder OCPD
	215.4(A)(1)Ex.3	overcurrent device	OCPD
	215.5 Title	Overcurrent protection	Fine as is
	215.5	Feeders shall be protected against overcurrent	Feeders shall be provided with overcurrent protection in accordance with Article 240, Parts I
	215.5	overcurrent device	OCPD
	215.5Ex	overcurrent device protecting the feeders	feeder OCPDs
	215.5Ex	overcurrent device	OCPD

	215.18(B)	branch circuit overcurrent devices	OCPDs
10	Article 225		
	225.40. Title	Overcurrent protective devices	Fine as is
	225.40.	feeder overcurrent device (x2)	feeder OCPD
	225.40.	branch circuit overcurrent devices	Branch circuit OCPDs
	225.42(B)	branch circuit overcurrent devices	OCPDs
10	Article 230		
	230.7 Ex.2	Overcurrent protection	Fine as is
	230.42(A)(1)	overcurrent device (X3)	OCPD
	230.82(6)	Overcurrent protection	Fine as is
	230.82(7)	Overcurrent protection	Fine as is
	230.82(8)	Overcurrent protection	Fine as is
	230.82(9)	Overcurrent protection	Fine as is
	230.82(10)	Overcurrent protection	Fine as is
	230 Part VII	Overcurrent protection	Fine as is
	230.90(A)	overcurrent device	OCPD
	230.90(A)Ex.3	overcurrent device	OCPD
	230.90(B)	overcurrent device	OCPD
	230.91	overcurrent device (X2)	OCPD
	230.92	overcurrent device (X4)	OCPDs and OCPD
	230.93	overcurrent device	OCPD
	230.94	overcurrent device (X3)	OCPD
	230.94	Overcurrent protection (X2)	Fine as is
	230.95(A)	overcurrent device	OCPD
	230.95(B)	overcurrent device	OCPD
10	Article 240		
	240	Overcurrent Protection	Fine as is
	240.1 (X3)	Overcurrent protection	Fine as is
	240.2	branch-circuit Overcurrent protective devices	branch-circuit Overcurrent protective devices
	240.4. Title	Protection of Conductors	Overcurrent Protection of Conductors
	240.4	Protected against overcurrent	shall be provided with overcurrent protection in accordance with
	240.4(B). Title	Overcurrent devices	Overcurrent protective Devices
	240.4(B)	Overcurrent device	OCPD
	240.4(B)	Overcurrent protective device	OCPD

	240.4(C). Title	Overcurrent devices	Overcurrent protective Devices
	240.4(C). (X2)	Overcurrent device.	OCPD
	240.4(D)	Overcurrent Protection	Fine as is
	240.4(D)(1)	Overcurrent protection	Fine as is
	240.4(D)(1)(2)		(a) OCPDs in accordance with 240.7 shall be marked for use with 18 AWG copper conductor (b) Delete (c) change to (b)
	240.4(D)(2)	Overcurrent protection	Fine as is
	240.4(D)(2)(2)		(a) OCPDs in accordance with 240.7 shall be marked for use with 16 AWG copper conductor (b) Delete (c) change to (b)
	240.4(D)(3)	Overcurrent protection	Fine as is
	240.4(D)(3)(2)		(a) Fuses and circuit breakers in accordance with 240.7 marked for use with 14 AWG copper clad aluminum conductor (b) Delete
	240.4(D)(3)(2)		OCPDs in accordance with 240.7 shall be marked for use with 14 AWG copper-clad aluminum conductor
	240.4(E)	Protected against overcurrent	shall be permitted to have overcurrent protection in accordance with the following
	240.4(F)	Overcurrent protection	Fine as is
	240.4(F)	Overcurrent protective device	OCPD
	240.4(G). (X2)	Overcurrent protection	Fine as is
	240.4(H)	Protected against overcurrent	shall be provided with overcurrent protection in accordance with
	240.5	Protected against overcurrent	shall be provided with overcurrent protection in accordance with
	240.5(A)	Overcurrent device	OCPD
	240.5(A)	Protected against overcurrent	Fixture wires shall be provided with overcurrent protection in accordance with
	240.5(A)	Supplementary overcurrent protection	Fine as is
	240.5(B) Title	Branch-circuit overcurrent device.	Branch-Circuit Overcurrent protective Devices

	240.9	Protection of conductors against overcurrent	Fine as is
	240.10. Title	Supplementary Overcurrent protection	Fine as is
	240.10.	Supplementary overcurrent protection	Fine as is
	240.10.	Branch-Circuit overcurrent devices	OCPDs
	240.10.	Supplementary overcurrent devices	Supplementary OCPDs
	240.11. (X2)	Feeder overcurrent protective devices.	Feeder OCPDs
	240.11. (X2)	Service overcurrent protective device.	Service OCPD
	240.15(A). Title	Overcurrent device	Overcurrent protective device required
	240.15(A)	Overcurrent device	OCPD
	240.15(A)	Overcurrent trip. Overcurrent relay	Fine as is
	240.15(B) Title	Overcurrent device	Circuit breaker as Overcurrent protective device
	240.16	Branch circuit overcurrent protective devices	OCPDs
	240.21	Overcurrent Protection	Fine as is
	240.21	overcurrent protective device	OCPD
	240.21 (A)	Overcurrent Protection	Fine as is
	240.21 (B)	Overcurrent Protection	Fine as is
	240.21 (B) (1) (1) (b)	Overcurrent device(s)	OCPDs
	240.21 (B) (1) (1) (b)	overcurrent protective device	OCPD
	240.21 (B)(1) (1) (4)	Overcurrent device	OCPD
	240.21 (B) (1)(1) (4) In	Overcurrent Protection	Fine as is
	240.21 (B) (2) (1)	Overcurrent device	OCPD
	240.21 (B) (2) (2)	Overcurrent devices	OCPDs
	240.21 (B) (3) (1)	Overcurrent device	OCPD
	240.21 (B) (3) (2)	Overcurrent device	OCPD
	240.21 (B) (4) (3)	Overcurrent device	OCPD
	240.21 (B) (4) (4)	Overcurrent device	OCPD
	240.21 (B) (4) (4)	Overcurrent devices	OCPDs
	240.21 (B) (5) (2)	Overcurrent device	OCPD
	240.21 (B) (5) (2)	Overcurrent devices	OCPDs
	240.21 (B) (5) (3)	Overcurrent device	OCPD
	240.21 (C). (X2)	Overcurrent Protection	Fine As Is
	240.21 (C) (1). Title	Title change	Overcurrent Protective Device
	240.21 (C) (1)	"...protected by overcurrent protection..."	Fine As Is
	240.21 (C) (1)	Overcurrent protective device	OCPD
	240.21 (C) (2) (1) (b)	Overcurrent device(s)	OCPDs

	240.21 (C) (2) (1) (b)	Overcurrent device	OCPD
	240.21 (C) (2) (4)	Overcurrent device	OCPD
	240.21 (C) (2) (4)	Overcurrent device	OCPD
	240.21 (C) (2) (4)	Overcurrent protection	Fine as is
	240.21 (C) (3) (2)	Overcurrent devices	OCPDs
	240.21 (C) (3) (3)	Overcurrent devices	OCPDs
	240.21 (C) (4) (2)	Overcurrent device	OCPD
	240.21 (C) (4) (2)	Overcurrent devices	OCPDs
	240.21 (C) (4) (3)	Overcurrent device	OCPD
	240.21 (C) (5)	Overcurrent Protection	Fine As Is
	240.21 (C) (6) (1)	Overcurrent device	OCPD
	240.21 (D)	Overcurrent devices	OCPDs
	240.21 (E)	.shall be permitted to be protected against overcurrent.	"..shall be permitted to have overcurrent protection.."
	240.21 (F)	.shall be permitted to be protected against overcurrent.	"..shall be permitted to have overcurrent protection.."
	240.21 (H) . (X 2)	Overcurrent Protection	Fine As Is
	240.22 . (X 2)	Overcurrent device	OCPD
	240.24(A)	Supplementary overcurrent protection	Fine as is
	240.24(A). (X 4)	Overcurrent protective devices	OCPDs
	240.24(B)	Overcurrent devices	OCPDs
	240.24(B)(1). Title	Feeder overcurrent protective devices	Feeder OCPDs
	240.24(B)(1)	Service overcurrent protective devices	Service OCPDs
	240.24(B)(2). TITLE	Branch-circuit overcurrent protective device	Fine as is
	240.24(B)(2).	Branch-circuit overcurrent protective device	Branch-Circuit OCPD
	240.24(C)	Overcurrent protective devices	OCPDs
	240.24(D)	Overcurrent protective devices	OCPDs
	240.24(E)	Overcurrent protective devices	OCPDs
	240.24(E)	Supplementary overcurrent protection	Fine as is
	240.24(E) (X 2)	Overcurrent protective devices	OCPDs
	240.24(F)	Overcurrent protective devices	OCPDs
	240.30(A)	Overcurrent devices	OCPDs
	240.32	Overcurrent devices	OCPDs
	240.33	Overcurrent devices	OCPDs
	240.86	Overcurrent device	OCPD
	240.86(B)	Overcurrent device	OCPD
	240.86(C)	Overcurrent device	OCPD

	240.87	Overcurrent device	OCPD
	240.90.	Overcurrent protection	Fine as is
	240.91(B). (X2)	Overcurrent device	OCPD
	240.92	Overcurrent device	OCPD
	240.92(A)	be protected	shall be provided with overcurrent protection
	240.92(C)	Overcurrent protection	Fine as is
	240.92(C)(1)(1)	Overcurrent device	OCPD
	240.92(C)(1)(2)	protective devices	Fine as is
	240.92(C)(1)(3)	Overcurrent devices	OCPDs
	240.92(C)(2)(1)	Overcurrent device	OCPD
	240.92(C)(2)(2) (X3)	Overcurrent devices	OCPDs
	240.92(C)(2)(3)	Overcurrent relaying	Fine as is
	240.92(C)(2)(4)	Overcurrent device	OCPD
	240.92(D)	Overcurrent protection	Fine as is
	240.92(D)(2). (X3)	Overcurrent devices	OCPDs
	240.92(D)(4)	Overcurrent device	OCPD
	240.92(E)	Overcurrent device	OCPD
	240.92(E)	Overcurrent protection	Fine as is
10	Article 242		
	242.14(ABC)	Overcurrent device	OCPD
	242.16	Overcurrent protection	Branch-circuit OCPD
10	Article 404		
	404.5	Overcurrent Devices	OCPDs
10	Article 408		
	408.4(A)	Overcurrent device	OCPD
	408.6 (X2)	Overcurrent protection devices	OCPDs
	408.36. Title	Overcurrent protection	Fine as is
	408.36. (X2)	Overcurrent protective device	OCPD
	408.36. (X3)	Overcurrent devices	OCPDs
	408.36(A)	Overcurrent protection	Fine as is
	408.36(B)	Overcurrent protection	Fine as is
	408.36(C)	Overcurrent device	OCPD
	408.36(D)	Overcurrent protection devices	OCPDs
	408.52	Overcurrent devices	OCPDs
	408.54	Overcurrent devices	OCPDs

	408.55	Overcurrent devices	OCPDs
--	--------	---------------------	-------

CMP-10 TG-4 Review of Overcurrent Language for the Articles under the purview of CMP-11

CMP	NEC Section (using First Draft of 2026 NEC)	Current Language	"New" Language
11	Article 409		
	409.21. TITLE	Overcurrent Protection	Fine as is
	409.21(A)	Overcurrent Protection	Fine as is
	409.21(B)	Protection	Overcurrent protection
	409.21(B)	overcurrent protective device	OCPD
	409.21(B)	Overcurrent Protection	Fine as is
	409.21(C). (X2)	overcurrent protective device	OCPD
	409.104	Overcurrent Devices	OCPDs
11	Article 430		
	430.10(A) In.	Overcurrent Device	OCPD
	430.22(G)(1)(1)	Overcurrent Protection	Fine as is
	430.22(G)(1)(2)	Overcurrent Protection	Fine as is
	430.22(G)(2)(1)	Overcurrent Protection	Fine as is
	430.22(G)(2)(2)	Overcurrent Protection	Fine as is
	430.28	Branch-Circuit protective device	OCPD
	430.28	Overcurrent Device	OCPD
	430.51	Overcurrent	Fine as is
	430.53(C)(5)	Overcurrent Protection	Fine as is
	430.55	Overcurrent Protection	Fine as is
	430.61	Overcurrents	Fine as is
	430.62(A)Ex.2	Feeder Overcurrent protective device	Feeder OCPD
	430.62(A)Ex.2	Overcurrent Protection	Fine as is
	430.62(B)	Feeder Overcurrent protective device	Feeder OCPD
	430.63Ex.	Feeder Overcurrent device	Feeder OCPD
	430.63Ex.	Overcurrent Protection	Fine as is
	430.72. Title	Overcurrent Protection	Fine as is
	430.72(A)	protected against overcurrent	shall be provided with overcurrent protection in accordance with
	430.72(A)	Branch-circuit overcurrent protective devices	OCPDs
	430.72(A)	protected against overcurrent	shall be provided with overcurrent protection in accordance with
	430.72(B). (X2)	Overcurrent Protection	Fine as is
	430.72(B)	Overcurrent Device	OCPD

	430.72(B)	Overcurrent Protection	Fine as is
	430.72(B)(1) (X3)	Overcurrent Protection	Fine as is
	430.72(B)(2) Title	Branch-circuit overcurrent protective device	Fine as is
	430.72(B)(2) (X2)	protective devices	OCPDs
	430.72(C)Ex.	Overcurrent Protection	Fine as is
	430.72(C)(3)	Overcurrent Devices	OCPDs
	430.72(C)(4)	Overcurrent Device	OCPD
	430.72(C)(5)	Protection	Overcurrent protection
	430.87	Overcurrent Device	OCPD
	430.94. (X2)	Overcurrent Protection	Fine as is
	430.94. (X3)	Overcurrent protective device	OCPD
	430.109(A)(7)	Overcurrent protection	Fine as is
	430.109(B)	Branch-circuit overcurrent device	branch-circuit OCPD
	430.111(A). (X2)	Overcurrent Device	Fine as is
	430.112 Ex.	Branch circuit protective device	Suggest CMP to Review
	430.206. Title	Overcurrent protection	Fine as is
	430.206(B)(2)	considered to have Overcurrent	Overload
	430.206(C)	Fault-Current protection	Suggest CMP to Review
	430.207	Overcurrent (overload)Relays	Fine as is
	430.207	Overcurrent Relays	Fine as is
11	Article 440		
	440.21	Overcurrent	Fine as is
	440.21	Overcurrent Protection	Fine as is
	440.22(B)(2)Ex.	Overcurrent device	OCPD
	440.52(B)	Overcurrent	shall be provided with overcurrent protection
11	Article 460		
	460.9. Title	Overcurrent Protection	Fine As Is
	460.9. (X3)	Overcurrent Device	OCPD
	460.25	Overcurrent Protection	Fine As Is
	460.28(B)	Overcurrent Device	OCPD

CMP-10 TG-4 Review of Overcurrent Language for the Articles under the purview of CMP-12

CMP	NEC Section (using First Draft of 2026 NEC)	Current Language	"New" Language
12	Article 610		
	610. Part V	Overcurrent Protection	Fine as is
	610.41(A)	Overcurrent Devices	OCPDs
	610.43(A)(1)	Branch Circuit Overcurrent Device	OCPD
	610.53 Title	Overcurrent Protection	Fine as is
	610.53	be protected from Overcurrent	shall be provided with overcurrent protection
	610.53	Overcurrent Devices	OCPDs
	610.53(B)	Branch Circuit Overcurrent Devices	OCPDs
12	Article 620		
	620.12(A)(4)	Overcurrent Protection	Fine as is
	620.22(A)(2) Title	Overcurrent protective device	Fine as is
	620.22(A)(2)	Overcurrent Device protecting	branch-circuit OCPD
	620.22(A)(2)	Overcurrent Device	OCPD
	620.22(B)	Overcurrent Device protecting	branch-circuit OCPD
	620.22(B)	Overcurrent Device	OCPD
	620.25 Title	Overcurrent Devices	Overcurrent Protective Devices
	620.25. (X2)	Overcurrent Devices	OCPDs
	620.53	Overcurrent protective device	OCPD
	620.54	Overcurrent protective device	OCPD
	620.55	Overcurrent protective device	OCPD
	Art 620 Part VII	Overcurrent Protection	Fine as is
	620.61	Overcurrent Protection	Fine as is
	620.61(A). (X2)	be protected against Overcurrent	shall be provided with overcurrent protection
	620.62(A)	Overcurrent protective devices, (OCPD)	OCPDs
	620.62(B)	OCPDs	Fine as is
	620.62(C)	OCPDs. And. Overcurrent Devices	Fine as is. And. OCPDs
	620.62	Overcurrent protective devices	OCPDs
	620.65. (X3)	Overcurrent Devices	OCPDs
12	Article 625		
	625.60(C). (X4)	Overcurrent Protection	Fine as is
12	Article 627		
	627.41	Overcurrent Protection	Fine as is
	627.41(A)	Overcurrent Protection	Fine as is

	627.41(B)	Overcurrent Devices	OCPDs
12	Article 630		
	630.12	Overcurrent Protection	Fine as is
	630.12	Overcurrent Device	OCPD
	630.12(A). (X2)	Overcurrent Protection	Fine as is
	630.12(A). (X5)	Overcurrent Device	OCPD
	630.13	Overcurrent Protection	Fine as is
	630.32	Overcurrent Protection	Fine as is
	630.32	Overcurrent Device	OCPD
12	Article 640		
	640.9(C)	Overcurrent Protection	Fine as is
	640.22	Overcurrent protection devices	OCPDs
	640.22	Overcurrent Devices	OCPDs
	640.43	Overcurrent protection devices	OCPDs
12	Article 645		
	645.27	Overcurrent protective devices, (OCPD)	OCPDs
	645.27	Overcurrent protective devices	OCPDs
12	Article 646		
	646.7. (X11)	Overcurrent Protection	Fine as is
12	Article 647		
	647.5	Overcurrent Protection	Fine as is
12	Article 650		
	650.9	Overcurrent Protection	Fine as is
	650.9	Overcurrent Device	OCPD
12	Article 660		
	660.7	Overcurrent Protection	Fine as is
	660.7(A)	Overcurrent protective devices	OCPDs
	660.7(B)	Overcurrent Devices	OCPDs
	660.7(B)	Overcurrent Protection	Fine as is
	660.9	Overcurrent Devices	OCPDs
12	Article 665		
	665.24	Overcurrent Protection	Fine as is
12	Article 668		
	668.4(C)(2)	Overcurrent Protection	Fine as is
	668.21	Overcurrent Protection	Fine as is

	668.21	Overcurrent Device	OCPD
12	Article 669		
	669.9	Overcurrent Protection	Fine as is
	669.9	be protected from Overcurrent	shall be provided with overcurrent protection
12	Article 670		
	670.1	Overcurrent Protection	Fine as is
	670.4(B). (X3)	Overcurrent Protection	Fine as is
	670.5. (X4)	Overcurrent Protection	Fine as is
	670.5(C). (X2)	Overcurrent protective device	OCPD
12	Article 685		
	685.10.	Overcurrent Devices	OCPDs

CMP-10 TG-4 Review of Overcurrent Language for the Articles under the purview of CMP-13

CMP	NEC Section (using First Draft of 2026 NEC)	Current Language	"New" Language
13	Article 100		
	Emerg. Power Supply Systems (EPSS)	overcurrent protection devices	overcurrent protective devices (OCPDs)
	Transfer-Switch B-C Emerg. Ltg.	branch-circuit overcurrent device	branch-circuit overcurrent protective device (OCPD)
13	Article 130		
	130.80(C)	overcurrent devices	OCPDs
	130.80(C)	branch-circuit overcurrent device	OCPD
13	Article 445		
	445.11	Overcurrent protective Relay	Fine as is
	445.12. Title	Overcurrent Protection	Fine as is
	445.12(A)	Overcurrent protective means	Overcurrent protection means
	445.12(B)	Overcurrent Protection	Fine as is
	445.12(B) (X2)	Overcurrent Device	OCPD
	445.12(C)	Overcurrent Device	OCPD
	445.12(D)	Overcurrent Devices	OCPDs
	445.12(E). (X3)	Overcurrent Devices	OCPDs
	445.13(A). (X2)	Overcurrent Protection	Fine as is
	445.13(B). Title	Overcurrent protection	Fine as is
	445.13(B).	Overcurrent protective device	OCPD
	445.13(B)	Overcurrent Relay	Fine as is
13	Article 455		
	455.7	Overcurrent Protection	Fine As Is
	455.7	protected from Overcurrent	shall be provided with overcurrent protection in accordance with
	455.7(A)	Overcurrent Protection	Fine As Is
	455.7(B)	Overcurrent Protection	Fine As Is
13	Article 480		
	480.4(B) IN.2	Overcurrent Protection	Fine As Is
	480.6. (X2)	Overcurrent Protection	Fine As Is
	480.7	Overcurrent Device	OCPD
13	Article 695		
	695.4(C)	Overcurrent protective devices	OCPDs
	695.4(H). Title	Overcurrent Device Selection	Overcurrent Protective Device Selection
	695.4(H)	Overcurrent Devices	OCPDs

	695.5	Overcurrent Device	OCPD
	695.5	Overcurrent protective devices	OCPDs
	695.5	Overcurrent Protection	Fine as is
	695.6	Overcurrent protective devices	OCPDs
	695.6	Overcurrent Devices	OCPD
	695.6	Overcurrent Protection	Fine as is
	695.7(A)(2)	Overcurrent Devices	OCPDs
	695.7	Overcurrent Protection	Fine as is
13	Article 700		
	700.4(F)(8)	Overcurrent protective devices, (OCPD)	OCPDs
	700.6(E)	Overcurrent protective device	OCPD
	700.10(B). (X6)	Overcurrent Protection	Fine as is
	700.10(B)(6)(b)(ii)	Overcurrent protective device	OCPD
	700.10(B)(6)(e)	Overcurrent protective devices	OCPDs
	Art. 700 Part VI	Overcurrent Protection	Fine as is
	700.30.	Branch-circuit overcurrent devices	OCPDs
	700.32(A)	Overcurrent protective devices, (OCPDs)	OCPDs
	700.32(A) In	Overcurrent Protection	Fine as is
	700.32(C)	Overcurrent Devices	OCPDs
13	Article 701		
	701.6(C)	Overcurrent protective device	OCPD
	701.10(B)(1). (X5)	Overcurrent Protection	Fine as is
	701.10(B)(1)	Overcurrent protective device	OCPD
	Art. 701. Part IV	Overcurrent Protection	OCPDs
	701.30.	Branch-Circuit Overcurrent devices	Branch-Circuit OCPDs
	701.32(A). (X2)	Overcurrent protective devices, OCPDs	OCPDs
	701.32(B). (X3)	OCPDs	Fine as is
	701.32(C). (X2)	OCPDs	Fine as is
	701.32(C)Ex	Overcurrent Devices	OCPDs
	701.32(C) In 2	OCPD and OCPDs	Fine as is
13	Article 702		
	702.5(C)	Overcurrent protective device	OCPD
13	Article 706		
	706.15(E)(1)	Overcurrent Device	OCPD
	706.30(B)	Overcurrent Devices	OCPDs

	706.31 Title	Overcurrent Protection	Fine as is
	706.31(A)	shall be protected at the source from overcurrent.	shall be provided with overcurrent protection at the source
	706.31(A)	shall be protected from overcurrent.	shall be provided with overcurrent protection
	706.31(A) In	Overcurrent Device	OCPD
	706.31(B). Title	Overcurrent Device	Overcurrent Protective Device
	706.31(B)	Overcurrent protective devices	OCPDs
	706.31(B)	Overcurrent devices	OCPDs
	706.31(C)	Overcurrent protective devices	OCPDs
	706.31(E)	Overcurrent Protection	Fine as is
	706.33(B)(2)	Overcurrent Device	OCPD
13	Article 708		
	708.10(B)	Overcurrent Protection	Fine as is
	708.24(E)	Overcurrent protective device	OCPD
	Art. 708. Part IV	Overcurrent Protection	Fine as is
	708.50.	Feeder- and Branch-circuit overcurrent devices	Feeder- and Branch-circuit OCPDs
	708.52(B)	Overcurrent Devices	OCPDs
	708.54(A)	Overcurrent protective devices, (OCPD)	OCPDs
	708.54(A). (B). (C)	OCPDs	Fine as is
	708.54	Overcurrent Devices	OCPDs

CMP-10 TG-4 Review of Overcurrent Language for the Articles under the purview of CMP-14

CMP	NEC Section (using First Draft of 2026 NEC)	Current Language	"New" Language
14	Article 500		
	500.30(A)(2)	Branch Circuit Overcurrent Protection	OCPD
	500.30.	Overcurrent Protection	Fine as is
14	Article 501		
	501.105(B)(5)	Overcurrent Protection	Fine as is
	501.125(B)(2)	Motor Overcurrent	Fine as is
14	Article 502		
	502.120(A)	Overcurrent Devices	OCPDs
	502.120(B)(1)	Overcurrent Devices	OCPDs
	502.125	Motor Overcurrent	Fine as is
14	Article 505		
	505.30(A)(2)	Branch Circuit Overcurrent Protection	OCPD
	505.30.	Overcurrent Protection	Fine as is
14	Article 506		
	506.30.	Branch Circuit Overcurrent Protection	OCPD
	506.30.	Overcurrent Protection	Fine as is

CMP-10 TG-4 Review of Overcurrent Language for the Articles under the purview of CMP-15

CMP	NEC Section (using First Draft of 2026 NEC)	Current Language	"New" Language
15	Article 100		
	Bull Switch	Overcurrent protection	Fine as is
15	Article 517		
	517.17(B)	Overcurrent protective devices	OCPDs
	517.31(G). (X5)	Overcurrent protective devices	OCPDs
	517.31(G)	Overcurrent	Fine as is
	517.33((C). (X5)	Overcurrent protective devices	OCPDs
	517.42(F)	Overcurrent protective devices	OCPDs
	517.42(F)	Overcurrent	Fine as is
	517.73	Overcurrent Protection	Fine as is
	517.73(A)	Overcurrent protective devices	OCPDs
	517.73(B)	Overcurrent protective devices	OCPDs
	517.73(B)	Overcurrent Protection	Fine as is
	517.74(B)	Overcurrent protective devices	OCPDs
	517.160(A)(2)	Overcurrent Protection	Fine as is
	517.160(A)(2)	Overcurrent protective device	OCPD
	517.160(A)(2)	be protected against Overcurrent	be provided with overcurrent protection
	517.160(A)(3)	Overcurrent protective devices	OCPDs
	517.160(B)(1)	Overcurrent protective devices	OCPDs
15	Article 518		
	518.7(A)(1)	Overcurrent Protection	Fine as is
	518.17(A)(1) and (2)	Overcurrent Devices	OCPDs
15	Article 520		
	520.9	Branch Circuit Overcurrent Device	OCPD
	520.21	Overcurrent protective devices	OCPDs
	520.25. (X3)	Overcurrent Protection	Fine as is
	520.26	Overcurrent protective devices	OCPD
	520.26. (X3)	Overcurrent Protection	Fine as is
	520.27. (X2)	Overcurrent Device	OCPD
	520.44-T	Overcurrent Devices	OCPD
	520.50(C)	Overcurrent Protection	Fine as is
	520.50.	Branch-circuit overcurrent protective device	OCPDs
	520.52	Overcurrent Protection	Fine as is

	520.53(A)	Overcurrent protective devices	OCPDs
	520.53(D)	Overcurrent Protection	Fine as is
	520.54	Overcurrent Devices	OCPDs
	520.54(D)	Overcurrent Device	OCPD
	520.54(D)(1) and (2)	Overcurrent protective devices	OCPD
	520.54(E)	Overcurrent protective device	OCPD
	520.54(E). (X4)	Overcurrent protection device	OCPD
	520.54(E)	Overcurrent Devices	OCPDs
	520.54(K)	Overcurrent Device	OCPD
	520.68	Overcurrent protective device	OCPD
	520.68(3)	Overcurrent Device	OCPD
	520.68(4)	Overcurrent protective device	OCPD
	520.68(6)	Overcurrent Devices	OCPDs
	520.68(C)	Overcurrent Protection	Fine as is
15	Article 522		
	522.10(A)(2). (X3)	Overcurrent Devices	OCPDs
	522.10(A)(2)	Overcurrent protective device	OCPD
	522.10(B). (X4)	Overcurrent Devices	OCPDs
	522.23. (X3)	Overcurrent Protection	Fine as is
15	Article 525		
	525.12	Overcurrent Device	OCPD
	525.23(B)	Overcurrent Device	OCPD
	525.23(C). (X2)	Overcurrent Protection	Fine as is
15	Article 530		
	530.9(A)	Branch-circuit overcurrent device	Branch-circuit OCPD
	530.10(C)	Overcurrent Protection	Fine as is
	530.23 and (A)	Overcurrent Protection	Fine as is
	530.23(B)	Overcurrent protective devices	OCPDs
	530.23(D)	Overcurrent Protection	Fine as is
	530.42	Overcurrent Protection	Fine as is
15	Article 540		
	540.11(B)	Overcurrent Devices	OCPDs

CMP-10 TG-4 Review of Overcurrent Language for the Articles under the purview of CMP-16

CMP	NEC Section (using First Draft of 2026 NEC)	Current Language	"New" Language
16	Article 830		
	830.15. (X4)	Overcurrent Protection	Fine as is

CMP-10 TG-4 Review of Overcurrent Language for the Articles under the purview of CMP-17

CMP	NEC Section (using First Draft of 2026 NEC)	Current Language	"New" Language
17	Article 422		
	422.5(C)	Branch-circuit overcurrent protective device	Branch-Circuit OCPD
	422.11. Title	Overcurrent Protection	Fine as is
	422.11	protected against overcurrent	shall be provided with overcurrent protection
	422.11(A)	Overcurrent Protection	Fine as is
	422.11(A)	Branch-circuit overcurrent protective device	Branch-Circuit OCPD
	422.11(B)	Overcurrent Protection	OCPDs
	422.11(C)	Overcurrent Protection	OCPDs
	422.11(D)	Overcurrent protective devices	OCPDs
	422.11(E)	Overcurrent Protection	Fine as is
	422.11(E)(1)	Overcurrent Protection	Fine as is
	422.11(E)(2)	Overcurrent Protection	Fine as is
	422.11(E)(3)	Overcurrent Protection	OCPD
	422.11(E)(3)	Overcurrent Device	OCPD
	422.11(F)(1)	Supplementary Overcurrent Protective Devices	Supplementary OCPDs
	422.11(F)(1)	Overcurrent Protective Devices	OCPDs
	422.11(G)	Overcurrent Protective Devices	OCPDs
	422.13	Overcurrent Protection	Fine as is
	422.31(A)	Branch-circuit overcurrent protective device	Branch-Circuit OCPD
	422.60(A)	Overcurrent Protection	Fine as is
	422.62(B)(1). (X2)	Overcurrent protective device	OCPD
17	Article 424		
	424.19	Supplementary Overcurrent Protective Devices	Supplementary OCPDs
	424.19(A)	Supplementary Overcurrent Protection	Fine as is
	424.19(A)	Supplementary Overcurrent Protection	Fine as is
	424.19(A)	Supplementary Overcurrent Protective Device(s)	Supplementary OCPDs
	424.19(B)	Supplementary Overcurrent Protection	Fine as is
	424.22	Overcurrent Protection	Fine as is
	424.22(A)	Overcurrent Protection	Fine as is
	424.22(A)	protected against overcurrent	"..shall be permitted to have overcurrent protection.."
	424.22(B)	Supplementary Overcurrent Protective Device	Supplementary OCPD
	424.22(C). Title	Overcurrent Protective Devices	Fine as is
	424.22(C)	Supplementary Overcurrent Protective Devices	Supplementary OCPDs

	424.22(C)	Overcurrent Protection	Fine as is
	424.22(C)	Supplementary Overcurrent Protection	Fine as is
	424.22(D) (X2)	Supplementary Overcurrent Protective Devices	Supplementary OCPDs
	424.22(E). (X3)	Supplementary Overcurrent Protective Devices	Supplementary OCPDs
	424.72	Overcurrent Protection	Fine as is
	424.72(A)	Overcurrent protective device	OCPD
	424.72(B)	Overcurrent protective device	OCPD
	424.72(C). Title	Supplementary Overcurrent Protective Devices	Fine as is
	424.72(C)	Supplementary Overcurrent Protective Devices	Supplementary OCPDs
	424.72(C)	Overcurrent Protection	Fine as is
	424.72(D). Title	Supplementary Overcurrent Protective Devices	Fine as is
	424.72(D).	Supplementary Overcurrent Protective Devices	Supplementary OCPDs
	424.72(D)	Overcurrent protective device	OCPD
	424.72(E)	Supplementary Overcurrent Protective Devices. (X3)	Supplementary OCPDs
	424.82	Overcurrent protective devices	OCPDs
17	Article 425		
	425.19	Supplementary Overcurrent Protective Devices	Supplementary OCPDs
	425.19(A). (X2)	Supplementary Overcurrent Protection	Fine as is
	425.19(A)	Supplementary Overcurrent Protective Devices	Supplementary OCPDs
	425.19(B)	Supplementary Overcurrent Protection	Fine as is
	425.22. Title	Overcurrent Protection	Fine as is
	425.22(A)	Overcurrent Protection	Fine as is
	425.22(A)	protected against overcurrent	"..shall be permitted to have overcurrent protection.."
	425.22(B)	Supplementary Overcurrent Protective Device	Supplementary OCPD
	425.22(C). Title	Overcurrent Protective Devices	Fine as is
	425.22(C)	Supplementary Overcurrent Protective Devices	Supplementary OCPDs
	425.22(C). (X2)	Supplementary Overcurrent Protection	Fine as is
	425.22(D). Title	Supplementary Overcurrent Protective Devices	Fine as is
	425.22(D). (X2)	Supplementary Overcurrent Protective Devices	Supplementary OCPDs
	425.22(E) (X3)	Supplementary Overcurrent Protective Devices	Supplementary OCPDs
	425.72	Overcurrent Protection	Fine as is
	425.72(A)	Overcurrent protective device	OCPD
	425.72(B)	Overcurrent protective device	OCPD
	425.72(C). Title	Supplementary Overcurrent Protective Devices	Fine as is
	425.72(C)	Supplementary Overcurrent Protective Devices	Supplementary OCPDs

	425.72(C)	Overcurrent Protection	Fine as is
	425.72(D)	Overcurrent protection	Fine as is
	425.72(E). Title	Supplementary Overcurrent Protective Devices	Fine as is
	425.72(E)	Supplementary Overcurrent Protective Devices	Supplementary OCPDs
	425.72(E)	Overcurrent Protective Devices	OCPD
	425.72(F). (X3)	Supplementary Overcurrent Protective Devices	Supplementary OCPDs
	425.82	Overcurrent protective devices	OCPDs
17	Article 427		
	427.57	Overcurrent Protection	Fine as is
	427.57	considered protected against Overcurrent	considered to have overcurrent protection
17	Article 680		
	680.10.(A)& (B)(2)	Overcurrent protective devices	OCPDs
	680.23(F)(2)	Overcurrent Protection	Fine as is

CMP-10 TG-4 Review of Overcurrent Language for the Articles under the purview of CMP-18

CMP	NEC Section (using First Draft of 2026 NEC)	Current Language	"New" Language
18	Article 393		
	393.45. Title	Overcurrent Protection	Overcurrent Protection
	393.45(A)	Overcurrent Protection	Fine as is
18	Article 406		
	406.46(F)	Overcurrent Device	OCPD
18	Article 410		
	410.59(A)	Branch-circuit overcurrent devices	Branch-Circuit OCPD
	410.153	Overcurrent Protection	Fine as is
18	Article 600		
	600.41	Overcurrent	CMP to Review



Public Comment No. 2052-NFPA 70-2024 [New Article after 100]

Equipment Ground-Fault Protective Device (EGFPD)

Equipment Ground-Fault Protective Device (EGFPD)

A device intended for the detection of sensitive ground-fault currents, when the selectable ground-fault pick-up level is 6mA or up to 100mA, and interrupts a faulted circuit in accordance to the time intervals established by a Class A device.

Informational Note:

See UL Category FTTE, Equipment Ground-Fault Protective Devices, for further information. This product category is listed according to requirements in UL 1053, Standard for Ground-Fault Sensing and Relaying Equipment, and UL 943, Standard for Ground-Fault Circuit Interrupters.

Statement of Problem and Substantiation for Public Comment

This definition is being added as a supplement to Public Comment 2049 for revisions to 555.35. Personnel protection requires speed that GFPE devices are not tested or certified to. So if the intent is to protect humans from Electric Shock Drowning Incidents, and the minimum pickup threshold needs to be raised to 30mA at the pedestal and 100mA at the feeder for compatibility with boats, then the speed at which those protective devices operate should still follow the personnel protection formula of UL 943. EGFPDs are different devices than GFPE. While officially they cannot be considered personnel level protection, because of their adjustable settings, they are tested and certified to follow the personnel protection curve of UL 943.

Related Item

- PI4434

Submitter Information Verification

Submitter Full Name: Mark Pollock

Organization: Littelfuse

Street Address:

City:

State:

Zip:

Submittal Date: Wed Aug 28 17:04:12 EDT 2024

Committee: NEC-P15



Public Comment No. 666-NFPA 70-2024 [Definition: Motion Picture Sound Stage.]

Motion Picture Sound Stage.

A building or portion of a building, usually insulated from outside noise and natural light, designed, constructed, or altered for the purpose of image capture. (CMP-15)

Additional Proposed Changes

<u>File Name</u>	<u>Description</u>	<u>Approved</u>
CN_367.pdf		

Statement of Problem and Substantiation for Public Comment

NOTE: The following CC Note No. 367 appeared in the First Draft Report on First Revision No. 9131.

The panel should confirm this term is used in the code, or the definition should be removed. The CC has reviewed Chapter 5 and the term is not currently used. The term was deleted in the 2023 edition at second draft because the term was not used.

Related Item

- First Revision No. 9131

Submitter Information Verification

Submitter Full Name: CC Notes

Organization: NEC Correlating Committee

Street Address:

City:

State:

Zip:

Submittal Date: Fri Aug 02 10:18:41 EDT 2024

Committee: NEC-P15



Correlating Committee Note No. 367-NFPA 70-2024 [Definition: Motion

Picture Sound Stage.]

Submitter Information Verification

Committee: NEC-AAC

Submittal Date: Fri May 10 09:58:35 EDT 2024

Committee Statement

Committee Statement: The panel should confirm this term is used in the code, or the definition should be removed. The CC has reviewed Chapter 5 and the term is not currently used. The term was deleted in the 2023 edition at second draft because the term was not used.

First Revision No. 9131-NFPA 70-2024 [New Definition after Definition: Motion Picture Studio (Tel...]

Ballot Results

✔ **This item has passed ballot**

12 Eligible Voters

1 Not Returned

11 Affirmative All

0 Affirmative with Comments

0 Negative with Comments

0 Abstention

Not Returned

McDaniel, Roger D.

Affirmative All

Ayer, Lawrence S.

Bowmer, Trevor N.

Hickman, Palmer L.

Holub, Richard A.

Jackson, Peter D.

Kendall, David H.

Manche, Alan

Osborne, Robert D.

Porter, Christine T.

Schultheis, Timothy James

Williams, David A.



Public Comment No. 502-NFPA 70-2024 [Definition: Road Show Connection

Panel.]

Road Show Connection Panel.

A type of patch panel designed to allow for road show connection of portable stage switchboards to fixed lighting outlets by means of permanently installed supplementary circuits. (520) (CMP-15)

Additional Proposed Changes

<u>File Name</u>	<u>Description</u>	<u>Approved</u>
CN_154.pdf		

Statement of Problem and Substantiation for Public Comment

NOTE: The following CC Note No. 154 appeared in the First Draft Report on First Revision No. 9282.

The Correlating Committee directs CMP-15 to review the definition “Road Show Connection Panel” and clarify the undefined term “patch panel”.

Related Item

- First Revision No. 9282

Submitter Information Verification

Submitter Full Name: CC Notes

Organization: NEC Correlating Committee

Street Address:

City:

State:

Zip:

Submittal Date: Tue Jul 30 22:25:29 EDT 2024

Committee: NEC-P15



Correlating Committee Note No. 154-NFPA 70-2024 [Definition: Road Show

Connection Panel.]

Submitter Information Verification

Committee: NEC-AAC

Submittal Date: Thu May 09 08:12:10 EDT 2024

Committee Statement

Committee Statement: The Correlating Committee directs CMP-15 to review the definition “Road Show Connection Panel” and clarify the undefined term “patch panel”.

First Revision No. 9282-NFPA 70-2024 [New Definition after Definition: Riser Cable, Cable Routing...]

Ballot Results

✓ **This item has passed ballot**

12 Eligible Voters

1 Not Returned

11 Affirmative All

0 Affirmative with Comments

0 Negative with Comments

0 Abstention

Not Returned

McDaniel, Roger D.

Affirmative All

Ayer, Lawrence S.

Bowmer, Trevor N.

Hickman, Palmer L.

Holub, Richard A.

Jackson, Peter D.

Kendall, David H.

Manche, Alan

Osborne, Robert D.

Porter, Christine T.

Schultheis, Timothy James

Williams, David A.



Public Comment No. 961-NFPA 70-2024 [Article 517]

FOR THE SAKE OF CLARITY AND FUNCTIONALITY CAN WE PLEASE START ART. 517 SEPARATE FROM THE DIAGRAMS FROM ART. 516. ART. 517 IS HEADERED AND IMMEDIATELY FOLLOWED BY FIGURES 516.29(1), 516.29(2), 516.29(3), 516.29(4) AND FIGURE 516.35. THIS FEELS MESSY AND POSSIBLY MAY LEAD TO MISINTERPERATION OF ART 516 DUE TO NOT LOCATING ILLUSTRATED FIGURES AS WELL AS NOT BEING CLEAR ON THE START OF ART. 517.

Article 517 Health Care Facilities

Part I. General

517.1 Scope.

This article applies to electrical construction and installation criteria in health care facilities that provide services to human beings.

The requirements of this article shall specify the installation criteria and wiring methods that ensure reliable electrical service to the health care facility and minimize electrical hazards by the maintenance of adequately low potential differences only between exposed conductive surfaces that are likely to become energized and could be contacted by a patient.

Informational Note No. 1: In a health care facility, it is difficult to prevent the occurrence of a conductive or capacitive path from the patient's body to some grounded object, because that path might be established accidentally or through instrumentation directly connected to the patient. Other electrically conductive surfaces that might make additional contact with the patient, or instruments that might be connected to the patient, then become possible sources of electric currents that can traverse the patient's body. The hazard is increased as more apparatus is associated with the patient, therefore more intensive precautions are needed. Control of electric shock hazard requires the limitation of electric current that might flow in an electrical circuit involving the patient's body by raising the resistance of the conductive circuit that includes the patient, or by insulating exposed conductive surfaces that might become energized, in addition to reducing the potential difference that can appear between exposed conductive surfaces in the patient care vicinity, or by combinations of these methods. A special problem is presented by the patient with an externalized direct conductive path to the heart muscle. The patient could be electrocuted at current levels so low that additional protection in the design of appliances, insulation of the catheter, and control of medical practice is required.

The requirements in Article 517, Parts II and III, not only apply to single-function buildings but are also intended to be individually applied to their respective forms of occupancy within a multifunction building [e.g., a doctor's examining room located within a limited care facility would be required to meet 517.10(A)].

Informational Note No. 2 : For information concerning performance, maintenance, and testing criteria, refer to the appropriate health care facilities documents.

Informational Note No. 3: Text that is followed by a reference in brackets has been extracted from NFPA 99-2024, *Health Care Facilities Code*, or NFPA 101-2024, *Life Safety Code*. Only editorial changes were made to the extracted text to make it consistent with this code.

517.6 Patient Care–Related Electrical Equipment.

The reconditioning requirements of this code shall not apply to patient care–related electrical equipment.

Informational Note No. 1: Patient care–related electrical equipment is differentiated from electrical equipment as described in 110.21(A)(2).

Informational Note No. 2: If patient care–related electrical equipment is relocated, it is expected to be recommissioned or recertified in accordance with the U.S. *Federal Food, Drug, and Cosmetic Act (FDCA)*.

Informational Note No. 3: *Patient care–related electrical equipment* is defined in NFPA 99-2024, *Health Care Facilities Code*, 3.3.144, as an electrical equipment appliance that is intended to be used for diagnostic, therapeutic, or monitoring purposes in a patient care vicinity.

517.7 Patient Care Space Risk Categories and Risk Assessment.

(A) Risk Categories.

All activities, as well as systems or equipment that are new or altered, shall be designed and installed to meet Category 1 through Category 4 requirements, as detailed in this code. [99:4.1]

Activities, systems, and equipment shall be permitted to be designed and installed to a higher risk category. [99:4.1.5]

(1) Category 1.

Activities, systems, or equipment whose failure is likely to cause major injury or death of patients, staff, or visitors shall be designed and installed to meet Category 1 requirements, as detailed in this code. [99:4.1.1]

(2) Category 2.

Activities, systems, or equipment whose failure is likely to cause minor injury of patients, staff, or visitors shall be designed and installed to meet Category 2 requirements, as detailed in this code. [99:4.1.2]

(3) Category 3.

Activities, systems, or equipment whose failure is not likely to cause injury of patients, staff, or visitors shall be designed and installed to meet Category 3 requirements, as detailed in this code. [99:4.1.3]

(4) Category 4.

Activities, systems, or equipment whose failure would have no impact on patient care shall be designed and installed to meet Category 4 requirements, as detailed in this code. [99:4.1.4]

Informational Note No. 1: Major injury can include the following:

- (1) Any amputation
- (2) Loss of the sight of an eye (whether temporary or permanent)
- (3) Chemical or hot metal burn to the eye or any penetrating injury to the eye
- (4) Any injury that results in electric shock and electric burns leading to unconsciousness and that requires resuscitation or admittance to a hospital for 24 hours or more
- (5) Any other injury leading to hypothermia, heat induced illness, or unconsciousness requiring resuscitation or admittance to a hospital for 24 hours or more
- (6) Loss of consciousness caused by asphyxia or lack of oxygen or exposure to a biological agent or harmful substance
- (7) Absorption of any substance by inhalation, skin, or ingestion causing loss of consciousness or acute illness requiring medical treatment
- (8) Acute illness requiring medical treatment where there is reason to believe the exposure was to biological agents, its toxins, or infected materials

[99:A.4.1.1]

Informational Note No. 2: A minor injury means not serious or involving risk of life.

[99:A.4.1.2]

(B) Risk Assessment.

The health care facility's governing body shall establish the processes and operations that are planned for the health care facility. [99:4.2.1]

The governing body shall conduct risk assessments and shall determine risk categories based on the character of the processes and operations conducted in the health care facility.

[99:4.2.1.1]

Risk categories shall be classified by the health care facility's governing body by following and documenting a defined risk assessment procedure. [99:4.2.2]

Where required by the authority having jurisdiction, the risk assessment shall be provided to the authority having jurisdiction for review based on the character of the processes and operations conducted in the health care facility. [99:4.2.2.1]

A documented risk assessment shall not be required where Category 1 is selected. [99:4.2.3]

Informational Note: See ISO/IEC 31010-2019, *Risk Management — Risk Assessment Techniques*; NFPA 551-2022, *Guide for the Evaluation of Fire Risk Assessments*; SEMI S10-0307E, *Safety Guideline for Risk Assessment and Risk Evaluation Process*; or SFPE's *Engineering Guide to Fire Risk Assessment* (2006) for information and guidance on risk assessment procedures. The results of the assessment procedure should be documented and records retained.

[99:A.4.2]

Part II. Wiring and Protection

517.10 Applicability.

(A) Applicability.

Part II shall apply to patient care space of all health care facilities.

(B) Not Covered.

Article 517, Part II, shall not apply to the following:

- (1) Spaces not intended for direct patient care
- (2) Spaces of nursing homes and limited care facilities wired in accordance with Chapters 1 through 4 of this code where these spaces are used exclusively as patient sleeping rooms, as determined by the health care facility's governing body

Informational Note No. 1: See 406.26(5) for receptacles located in health care facility business offices, corridors, and waiting rooms that are required to be tamper resistant.

Informational Note No. 2: See 210.12(D) for branch circuits supplying outlets and receptacles located in patient sleeping rooms in nursing homes and limited care facilities that are connected to arc-fault circuit-interrupter circuits.

- (3) Spaces used exclusively for any of the following purposes:
 - (4) Intramuscular (IM), subcutaneous (SC), and intradermal (ID) injections (immunizations)
 - (5) Psychiatry and psychotherapy
 - (6) Alternative medicine
 - (7) Optometry
 - (8) Pharmacy services not contiguous to health care facilities

Informational Note No. 3: See NFPA 101-2024, Life Safety Code .

Informational Note No. 4: Intravenous (IV) infusions and transfusions, epidural infusions, and intraosseous (OS) injections are not considered to be intramuscular (IM), subcutaneous (SC), or intradermal (ID) injections, and are considered medical procedures accompanied by greater patient risk. IV infusions and transfusions are not considered to be alternative medicine.

Informational Note No. 5: See 517.8 for definitions of patient care space categories.

Informational Note No. 6: Spaces that provide direct patient care may need to meet the grounding and bonding requirements of this section when procedures are performed that provide a direct electrical pathway to the heart. NFPA 99-2024, *Health Care Facilities Code*, 3.3.43, defines direct electrical pathway to the heart as an externalized conductive pathway, insulated except at its ends, one end of which is in direct contact with heart muscle while the other is outside the body and is accessible for inadvertent or intentional contact with grounded objects or energized, ground-referenced sources. Electrodes, such as those used for pacing the heart, and catheters filled with conductive fluids are examples of direct electrical pathways to the heart.

517.12 Wiring Methods.

Except as modified in this article, wiring methods shall comply with Chapters 1 through 4 of this Code.

517.13 Equipment Grounding Conductor for Receptacles and Fixed Electrical Equipment in Patient Care Spaces.

Wiring serving patient care spaces shall comply with the requirements of 517.13(A) and 517.13(B).

Exception: Luminaires more than 2.3 m (7½ ft) above the floor and switches located outside of the patient care vicinity shall be permitted to be connected to an equipment grounding return path complying with the requirements of 517.13(A) or 517.13(B).

(A) Wiring Methods.

All branch circuits serving patient care spaces shall be provided with an effective ground-fault current path by installation in a metal raceway system or a cable having a metallic armor or sheath assembly. The metal raceway system, metallic cable armor, or sheath assembly shall itself qualify as an equipment grounding conductor in accordance with 250.118.

Informational Note: A metal raceway system includes outlet boxes, device boxes, junction boxes, and other wiring enclosures.

(B) Insulated Equipment Grounding Conductors and Insulated Equipment Bonding Jumpers.

(1) General.

Insulated copper equipment grounding conductors that are clearly identified along their entire length by green insulation and installed with the branch circuit conductors within the wiring method in accordance with 517.13(A) shall be connected to the following:

- (1) Grounding terminals of all receptacles other than isolated ground receptacles
- (2) Metal outlet boxes, metal device boxes, or metal enclosures
- (3) Non-current-carrying conductive surfaces of fixed electrical equipment likely to become energized that are subject to personal contact, operating at over 100 volts

Exception No. 1: For other than isolated ground receptacles, an insulated equipment bonding jumper that directly connects to the equipment grounding conductor shall be permitted to connect the box and receptacle(s) to the equipment grounding conductor. Isolated ground receptacles shall be connected in accordance with 517.16.

Exception No. 2: Metal faceplates shall be connected to an effective ground-fault current path by means of a metal mounting screw(s) securing the faceplate to a metal yoke or strap of a device or to a metal outlet box.

(2) Sizing.

Equipment grounding conductors and equipment bonding jumpers shall be sized in accordance with 250.122.

517.14 Panelboard Enclosure Bonding.

The equipment grounding terminal buses of the normal and essential branch-circuit panelboards serving the same individual patient care vicinity shall be connected together with an insulated continuous copper conductor not smaller than 10 AWG. Where two or more enclosed panelboards serving the same individual patient care vicinity are served from separate transfer switches on the essential electrical system, the equipment grounding terminal buses of those panelboard enclosures shall be connected together with an insulated continuous copper conductor not smaller than 10 AWG. This conductor shall be permitted to be broken in order to terminate on the equipment grounding terminal bus in each panelboard enclosure.

Exception: The insulated continuous copper conductor not smaller than 10 AWG shall be permitted to be terminated on listed connections to aluminum or copper busbars not smaller than 6 mm thick × 50 mm wide (¼ in. thick × 2 in. wide) and of sufficient length to accommodate the number of terminations necessary for the bonding of the panelboards enclosure. The busbar shall be securely fastened and installed in an accessible location.

517.16 Use of Isolated Ground Receptacles.

An isolated ground receptacle, if used, shall not defeat the purposes of the safety features of the grounding systems detailed in 517.13. [99:6.3.2.2.5(A)]

(A) Inside of a Patient Care Vicinity.

An isolated ground receptacle shall not be installed within a patient care vicinity. [99:6.3.2.2.5(B)]

(B) Outside of a Patient Care Vicinity.

Isolated ground receptacle(s) installed in patient care spaces outside of a patient care vicinity(s) shall comply with 517.16(B)(1) and 517.16(B)(2).

(1)

The equipment grounding terminals of isolated ground receptacles installed in branch circuits for patient care spaces shall be connected to an insulated equipment grounding conductor in accordance with 250.146(D) installed in a wiring method described in 517.13(A).

The equipment grounding conductor connected to the equipment grounding terminals of isolated ground receptacles in patient care spaces shall be clearly identified along the equipment grounding conductor's entire length by green insulation with one or more yellow stripes.

(2)

The insulated equipment grounding conductor required in 517.13(B)(1) shall be clearly identified along its entire length by green insulation, with no yellow stripes, and shall not be connected to the grounding terminals of isolated equipment ground receptacles but shall be connected to the box or enclosure indicated in 517.13(B)(1)(2) and to non-current-carrying conductive surfaces of fixed electrical equipment indicated in 517.13(B)(1)(3).

Informational Note No. 1: This type of installation is typically used where a reduction of electrical noise (electromagnetic interference) is necessary, and parallel grounding paths are to be avoided.

Informational Note No. 2: Care should be taken in specifying a system containing isolated ground receptacles, because the impedance of the effective ground-fault current path is dependent upon the equipment grounding conductor(s) and does not benefit from any conduit or building structure in parallel with the equipment grounding conductor.

517.17 Ground-Fault Protection of Equipment.

(A) Applicability.

The requirements of 517.17 shall apply to buildings or portions of buildings containing health care facilities with Category 1 spaces or utilizing electrical life-support equipment, and buildings that provide the required essential utilities or services for the operation of Category 1 spaces or electrical life-support equipment.

(B) Feeders.

Where ground-fault protection of equipment is provided for operation of the service disconnecting means or feeder disconnecting means as specified by 230.95 or 215.10, an additional step of ground-fault protection shall be provided in all next level feeder disconnecting means downstream toward the load. Such protection shall consist of overcurrent protective devices or other protective equipment that causes the feeder disconnecting means to open.

Ground-fault protection of equipment with automatic disconnecting means shall not be required on alternate power supply sources, between alternate power supply sources and any essential electrical system transfer switch, or on the load side of any essential electrical system transfer switch. [99:6.7.2.1.2.1]

Ground-fault indication without automatic disconnection shall be provided at any on-site power source. [99:6.7.2.1.2.2]

(C) Selectivity.

Ground-fault protection of equipment for operation of the service and feeder disconnecting means shall be fully selective such that the feeder device, but not the service device, shall open on ground faults on the load side of the feeder device. Separation of ground-fault protection time-current characteristics shall conform to manufacturer's recommendations and shall consider all required tolerances and disconnect operating time to achieve 100 percent selectivity.

Informational Note: See 230.95 Informational Note, for transfer of alternate source where ground-fault protection is applied.

(D) Testing.

When ground-fault protection of equipment is first installed, each level shall be performance tested to ensure compliance with 517.17(C). This testing shall be conducted by a qualified person(s) using a test process in accordance with the instruction provided with the equipment. A written record of this testing shall be made and shall be available to the authority having jurisdiction.

517.18 Category 2 Spaces.

(A) Patient Bed Location.

Each patient bed location shall be supplied by at least two branch circuits, one from the critical branch and one from the normal system. All branch circuits from the normal system shall originate in the same panelboard. The electrical receptacles or the cover plate for the electrical receptacles supplied from the critical branch shall have a distinctive color or marking so as to be readily identifiable and shall also indicate the panelboard and branch-circuit number supplying them.

Branch circuits serving patient bed locations shall not be part of a multiwire branch circuit.

Exception No. 1: Branch circuits serving only special-purpose outlets or receptacles, such as portable X-ray outlets, shall not be required to be served from the same distribution panel or panels.

Exception No. 2: The requirements of 517.18(A) shall not apply to patient bed locations in clinics, medical and dental offices, and outpatient facilities; psychiatric, substance abuse, and rehabilitation hospitals; sleeping rooms of nursing homes; and limited care facilities meeting the requirements of 517.10(B)(2).

Exception No. 3: A Category 2 patient bed location served from two separate transfer switches on the critical branch shall not be required to have circuits from the normal system.

Exception No. 4: Circuits served by Type 2 essential electrical systems shall be permitted to be fed by the equipment branch of the essential electrical system.

(B) Patient Bed Location Receptacles.

(1) Minimum Number and Supply.

Each patient bed location shall be provided with a minimum of eight receptacles.

(2) Receptacle Requirements.

The receptacles required in 517.18(B)(1) shall be permitted to be of the single, duplex, or quadruplex type or any combination of the three. All receptacles shall be listed "hospital grade" and shall be so identified. The grounding terminal of each receptacle shall be connected to an insulated copper equipment grounding conductor sized in accordance with Table 250.122(A).

Exception No. 1: The requirements of 517.18(B)(1) and (B)(2) shall not apply to psychiatric, substance abuse, and rehabilitation hospitals meeting the requirements of 517.10(B)(2).

Exception No. 2: Psychiatric security rooms shall not be required to have receptacle outlets installed in the room.

Informational Note: It is not intended that there be a total, immediate replacement of existing non-hospital grade receptacles. It is intended, however, that non-hospital grade receptacles be replaced with hospital grade receptacles upon modification of use, renovation, or as existing receptacles need replacement.

(C) Designated Category 2 Pediatric Locations.

Receptacles that are located within patient rooms, bathrooms, playrooms, and activity rooms of pediatric units or spaces with similar risk as determined by the health care facility's governing body by conducting a risk assessment, other than infant nurseries, shall be listed and identified as "tamper resistant" or shall employ a listed tamper-resistant cover. [99:6.3.2.2.1(D)]

517.19 Category 1 Spaces.

(A) Patient Bed Location Branch Circuits.

Each patient bed location shall be supplied by at least two branch circuits, one or more from the critical branch and one or more from the normal system. At least one branch circuit from the critical branch shall supply an outlet(s) only at that bed location.

The electrical receptacles or the cover plates for the electrical receptacles supplied from the life safety and critical branches shall have a distinctive color or marking so as to be readily identifiable. [99:6.7.2.2.5(B)]

All branch circuits from the normal system shall be from a single panelboard. Critical branch receptacles shall be identified and shall also indicate the panelboard and circuit number supplying them.

Branch circuits serving patient bed locations shall not be part of a multiwire branch circuit.

Exception No. 1: Branch circuits serving only special-purpose receptacles or equipment in Category 1 spaces shall be permitted to be served by other panelboards.

Exception No. 2: Category 1 spaces served from two separate critical branch transfer switches shall not be required to have circuits from the normal system.

(B) Patient Bed Location Receptacles.

(1) Minimum Number and Supply.

Each patient bed location shall be provided with a minimum of 14 receptacles, with at least one connected to either of the following:

- (1) The normal system branch circuit required in 517.19(A)
- (2) A critical branch circuit supplied by a different transfer switch than the other receptacles at the same patient bed location

(2) Receptacle Requirements.

The receptacles required in 517.19(B)(1) shall be permitted to be of the single, duplex, or quadruplex type or any combination of the three. All receptacles shall be listed "hospital grade" and shall be so identified. The grounding terminal of each receptacle shall be connected to the reference grounding point by means of an insulated copper equipment grounding conductor.

(C) Operating Room Receptacles.

(1) Minimum Number and Supply.

Each operating room shall be provided with a minimum of 36 receptacles divided between at least two branch circuits. At least 12 receptacles, but no more than 24, shall be connected to either of the following:

- (1) The normal system branch circuit required in 517.19(A)
- (2) A critical branch circuit supplied by a different transfer switch than the other receptacles at the same location

(2) Receptacle Requirements.

The receptacles shall be permitted to be of the locking or nonlocking type and of the single, duplex, or quadruplex types or any combination of the three.

All nonlocking-type receptacles shall be listed hospital grade and so identified. The grounding terminal of each receptacle shall be connected to the reference grounding point by means of an insulated copper equipment grounding conductor.

(D) Patient Care Vicinity Grounding and Bonding (Optional).

A patient care vicinity shall be permitted to have a patient equipment grounding point. The patient equipment grounding point, where supplied, shall be permitted to contain one or more listed grounding and bonding jacks. An equipment bonding jumper not smaller than 10 AWG shall be used to connect the grounding terminal of all grounding-type receptacles to the patient equipment grounding point. The bonding conductor shall be permitted to be arranged centrally or looped as convenient.

Informational Note: Where there is no patient equipment grounding point, it is important that the distance between the reference grounding point and the patient care vicinity be as short as possible to minimize any potential differences.

(E) Equipment Grounding and Bonding.

Where a grounded electrical distribution system is used and a feeder installed in a metal raceway or Type MC or Type MI cable that qualifies as an equipment grounding conductor in accordance with 250.118 is installed, grounding of enclosures and equipment, such as panelboards, switchboards, and switchgear, shall be ensured by one of the following bonding means at each termination or junction point of the metal raceway or Type MC or Type MI cable:

- (1) A grounding bushing and a continuous copper bonding jumper, sized in accordance with 250.122, with the bonding jumper connected to the junction enclosure or the ground bus of the panel
- (2) Connection of feeder raceways or Type MC or Type MI cable to threaded hubs or bosses on terminating enclosures
- (3) Other approved devices such as bonding-type locknuts or bushings

Standard locknuts shall not be used for bonding.

(F) Additional Protective Techniques in Category 1 Spaces (Optional).

Isolated power systems shall be permitted to be used for Category 1 spaces, and, if used, the isolated power system equipment shall be listed as isolated power equipment. The isolated power system shall be designed and installed in accordance with 517.160.

Exception: The audible and visual indicators of the line isolation monitor shall be permitted to be located at the nursing station for the area being served.

(G) Isolated Power System Equipment Grounding.

Where an isolated ungrounded power source is used and limits the first-fault current to a low magnitude, the equipment grounding conductor associated with the secondary circuit shall be permitted to be run outside of the enclosure of the power conductors in the same circuit.

Informational Note: Although it is permitted to run the equipment grounding conductor outside of the conduit, it is safer to run it with the power conductors to provide better protection in case of a second ground fault.

(H) Special-Purpose Receptacle Grounding.

The equipment grounding conductor for special-purpose receptacles, such as the operation of mobile diagnostic imaging equipment, shall be extended to the reference grounding points of branch circuits for all locations likely to be served from such receptacles. Where such a circuit is served from an isolated ungrounded system, the equipment grounding conductor shall not be required to be run with the power conductors; however, the equipment grounding terminal of the special-purpose receptacle shall be connected to the reference grounding point.

517.20 Wet Procedure Locations.

(A) Receptacles and Fixed Equipment.

Wet procedure locations shall be provided with special protection against electric shock.

[99:6.3.2.3.1]

Special protection shall be provided by one of the following:

- (1) Isolated power systems that remain in operation in the event of a single line-to-ground fault condition that inherently limits the possible ground-fault current due to a first fault to a low value, without interrupting the power supply

Informational Note No. 1: Isolated power systems can eliminate the danger of electric shock to patients who might be more susceptible to leakage current and unable to move in their beds.

- (2) Power distribution system in which the power supply is interrupted if the ground-fault current does, in fact, exceed the trip value of a Class A GFCI [99:6.3.2.3.2(2)]
- (3) Where GFCI protection is used in an operating room, one of the following shall apply:
 - (4) Each receptacle shall be an individual GFCI device.
 - (5) Each receptacle shall be individually protected by a single GFCI device.

[99:6.3.2.3.9]

Informational Note No. 2 to (2) and (3): See ANSI/UL 943-2018, *Ground-Fault Circuit-Interrupters*, Annex E, and 110.3(B) for the manufacturers' installation instructions of listed GFCIs for information on the supply connection of life-support equipment to circuits providing GFCI protection of personnel at outlets.

- (6) See Annex E of ANSI/UL 943-2018, *Ground-Fault Circuit-Interrupters*, and 110.3(B) for the manufacturers' installation instructions of listed ground-fault circuit interrupters for information on the supply connection of life-support equipment to circuits providing ground-fault circuit-interrupter (GFCI) protection of personnel at outlets.

Exception: Branch circuits supplying only listed, fixed, therapeutic, and diagnostic equipment shall be permitted to be supplied from a grounded service, single- or 3-phase system if the following conditions are met:

- (1) *Wiring for grounded and isolated circuits does not occupy the same raceway.*
- (2) *All conductive surfaces of the equipment are connected to an insulated copper equipment grounding conductor.*

(B) Isolated Power Systems.

Where isolated power systems are used, the isolated power equipment shall be listed as isolated power equipment, and the isolated power systems shall be designed and installed in accordance with 517.160.

Informational Note: See Article 680, Part IV, for requirements on the installation of therapeutic pools and tubs.

517.21 Ground-Fault Circuit-Interrupter Protection for Personnel in Category 2 and Category 1 Spaces.

Receptacles shall not be required in bathrooms or toilet rooms. [99:6.3.2.2.2(D)]

Receptacles located in patient bathrooms and toilet rooms in Category 2 spaces shall have ground-fault circuit-interrupter protection in accordance with 210.8(B)(1).

Ground-fault circuit-interrupter protection for personnel shall not be required for receptacles installed in those Category 2 and Category 1 spaces where a basin, sink, or other similar plumbing fixture is installed in the patient bed location.

Informational Note: See ANSI/UL 943-2018, *Ground-Fault Circuit-Interrupters*, Annex E, and, in accordance with 110.3(B), the manufacturers' installation instructions of listed ground-fault circuit interrupters for information on the supply connection of life-support equipment to circuits providing ground-fault circuit-interrupter (GFCI) protection of personnel at outlets.

517.22 Demand Factors.

Demand factors for receptacle loads supplied by branch circuits not exceeding 150 volts to ground and installed in Category 1, Category 2, Category 3, and Category 4 patient care spaces shall be in accordance with 120.110.

Informational Note: See Article 100 for the definitions of patient care space categories.

Part III. Essential Electrical System (EES)

517.25 Essential Electrical Systems for Health Care Facilities.

Type 1 and Type 2 essential electrical systems (EES) for health care facilities shall comprise separate branches capable of supplying a limited amount of lighting and power service, which is considered essential for life safety and orderly cessation of procedures during the time normal electrical service is interrupted for any reason.

Informational Note: See NFPA 99-2024, *Health Care Facilities Code*, for information on essential electrical systems.

517.26 Application of Other Articles.

The requirements of Article 700 shall not apply.

517.29 Type 1 Essential Electrical Systems (EESs).

Type 1 essential electrical systems (EESs) shall comply with 517.29(A) and 517.29(B).

Informational Note: Type 1 essential electrical systems (EESs) are comprised of three separate branches capable of supplying a limited amount of lighting and power service that is considered essential for life safety and effective facility operation during the time the normal electrical service is interrupted for any reason. These three separate branches are the life safety, critical, and equipment branches. [99:A.6.7.5.1]

(A) Applicability.

The requirements of 517.29 through 517.35 shall apply to Type 1 EESs. Type 1 systems shall be required for Category 1 spaces. Type 1 systems shall be permitted to serve Category 2, Category 3, and Category 4 spaces.

Informational Note No. 1: See NFPA 99-2024, *Health Care Facilities Code*, for performance, maintenance, and testing requirements of EESs in hospitals. See NFPA 20-2022, *Standard for the Installation of Stationary Pumps for Fire Protection*, for installation of centrifugal fire pumps.

Informational Note No. 2: See NFPA 99-2024, *Health Care Facilities Code*, 6.7.5 and 6.7.6, for additional information on Type 1 and Type 2 EESs.

(B) Type 1 Essential Electrical Systems.

Category 1 spaces shall be served by a Type 1 EES. [99:6.4.1]

Category 1 spaces shall not be served by a Type 2 EES. [99:6.4.2]

517.30 Sources of Power.

(A) Independent Power Sources.

EES loads shall be served by two or more independent sources (or sets of sources). One source (or sets of sources) shall be on-site power production equipment, storage components, or a combination sized to supply the entire EES.

Informational Note: An example of a set of sources may be several generators that when combined serve the entire EES.

(B) On-Site Power Sources for the EES.

Power sources for the EES shall be one or more of the following as specified in 517.30(B)(1) through 517.30(B)(5).

(1) Generating Units.

Generating units shall be permitted to serve as the on-site power source for all or part of an EES.

(2) Fuel Cell Systems.

Fuel cell systems shall be permitted to serve as the on-site power source for all or part of an EES.

(a) $N + 1$ units shall be provided where N units have sufficient capacity to supply the demand load of the portion of the system served.

(b) Where life safety and critical portions of the distribution system are present, a connection shall be provided for a portable diesel generator.

Informational Note: See NFPA 853-2020, *Standard for the Installation of Stationary Fuel Cell Power Systems*, for information on installation of stationary fuel cells.

(3) Energy Storage Systems.

Energy storage systems shall be permitted to serve as the alternate source for all or part of an EES.

Informational Note: See NFPA 111-2022, *Standard on Stored Electrical Energy Emergency and Standby Power Systems*, for information on the installation of energy storage systems.

(4) Health Care Microgrid.

An EES shall be permitted to be supplied by a health care microgrid that also supplies nonessential loads. The health care microgrid shall be permitted to share distributed resources with the normal system. Health care microgrid systems shall be designed with sufficient reliability to provide effective facility operation consistent with the facility emergency operations plan. Health care microgrid system components shall not be compromised by failure of the normal source.

Informational Note: See NFPA 99-2024, *Health Care Facilities Code*, for information on health care microgrids.

(C) Utility Supply Power.

Utility supply power shall not be used as a source for the EES unless permitted elsewhere in this article.

Informational Note: See 517.35 and 517.45 for essential system loads that can be supplied from dual sources of utility supply power.

(D) Location of EES Components.

Electrical system components shall be located to minimize interruptions caused by natural forces common to the area or natural disasters identified in the facility's emergency operations plan. [99:6.2.4.1]

(1) Sources.

Installation of two independent sources (or sets of sources) shall be located to reduce the likelihood of simultaneous interruption of EES components and non-EES components.

(2) Feeders.

Feeders and associated raceways serving essential electrical system transfer equipment shall be located such that physical separation is provided between each of the electrical system's feeders to prevent possible simultaneous interruption. [99:6.2.4.3]

517.31 Requirements for the Essential Electrical System.

(A) Separate Branches.

Type 1 EESs shall be comprised of three separate branches — life safety, critical, and equipment — capable of supplying a limited amount of lighting and power service that is considered essential for life safety and effective hospital operation.

The division between the branches shall occur at transfer switches where more than one transfer switch is required. [99:6.7.2.2.1]

(B) Transfer Switches.

Transfer switches shall comply with one of the following:

- (1) The number of transfer switches to be used shall be based on reliability and design. Each branch of the essential electrical system shall have one or more transfer switches.
- (2) One transfer switch shall be permitted to serve one or more branches in a facility with a continuous load on the switch of 150 kVA (120 kW) or less. [99:6.7.2.2.3.2]

Informational Note No. 1: See NFPA 99-2024, *Health Care Facilities Code*, 6.7.3.1, 6.7.2.2.5, 6.7.2.2.5.15, and 6.7.2.2.7, for more information on transfer switches.

Informational Note No. 2: See Figure Informational Note 517.31(B)(1).

Informational Note No. 3: See Figure Informational Note 517.31(B)(2).

Figure Informational Note 517.31(B)(1) Type 1 EES — Minimum Requirement (Greater Than 150 kVA) for Transfer Switch Arrangement.

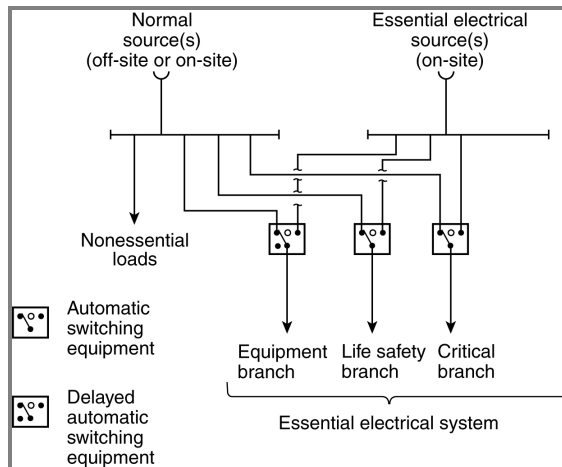
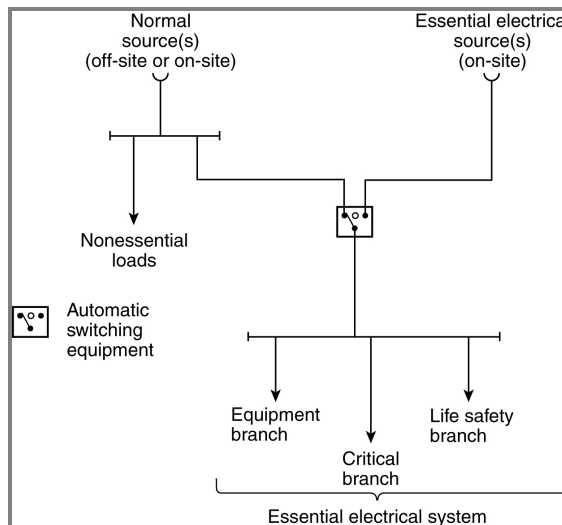

Figure Informational Note 517.31(B)(2) Type 1 EES — Minimum Requirement (150 kVA or Less) for Transfer Switch Arrangement.



(1) Optional Loads.

Loads served by an on-site source (or set of sources) not specifically named in this article shall be served by their own transfer switches such that the following conditions apply:

- (1) These loads shall not be transferred if the transfer will overload the on-site source(s).
- (2) These loads shall be automatically shed upon generating equipment overloading.

(2) Contiguous Facilities.

Hospital power sources and alternate power sources shall be permitted to serve the EESs of contiguous or same-site facilities.

(C) Wiring Requirements.

(1) Separation from Other Circuits.

The life safety branch and critical branch [of the essential electrical system] shall be kept independent of all other wiring and equipment. [99:6.7.5.2.1]

(a) Raceways, cables, or enclosures of the life safety and critical branch shall be readily identified as components of the essential electrical system (EES). Boxes and enclosures (including transfer switches, generators, and power panels) shall be field- or factory-marked and identified as components of the EES. Raceways and cables shall be field- or factory-marked as components of the EES at intervals not to exceed 7.6 m (25 ft).

(b) Conductors of the life safety branch or critical branch shall not enter the same raceways, boxes, or cabinets with each other or any other wiring system. Branch conductors shall be permitted to occupy common equipment, raceways, boxes, or cabinets of other circuits not part of the life safety branch and critical branch where such wiring complies with one of the following:

- (3) Is in transfer equipment enclosures
- (4) Is in exit or emergency luminaires supplied from two sources
- (5) Is in a common junction box attached to exit or emergency luminaires supplied from two sources
- (6) Is for two or more circuits supplied from the same branch and same transfer switch

(g) The wiring of the equipment branch shall be permitted to occupy the same raceways, boxes, or cabinets of other circuits that are not part of the essential electrical system.

(h) Where Category 2 locations are served from two separate transfer switches on the essential electrical system in accordance with 517.18(A) Exception No. 3, the Category 2 circuits from the two separate systems shall be kept independent of each other.

(i) Where Category 1 locations are served from two separate transfer switches on the essential electrical system in accordance with 517.19(A) Exception No. 2, the critical care circuits from the two separate systems shall be kept independent of each other.

(2) Isolated Power Systems.

Where isolated power systems are installed in any of the areas in 517.34(A)(1) and (A)(2), each system shall be supplied by an individual circuit serving no other load.

(3) Mechanical Protection of the Essential Electrical System.

The wiring of life safety and critical branches shall be mechanically protected by raceways. Where installed as branch circuits in patient care spaces, the installation shall comply with the requirements of 517.13(A), 517.13(B), and 250.118. Only the following wiring methods shall be permitted:

- (1) Nonflexible metal raceways, Type MI cable, RTRC marked with the suffix –XW, or Schedule 80 PVC conduit
- (2) Where encased in not less than 50 mm (2 in.) of concrete, Schedule 40 PVC conduit, flexible nonmetallic or jacketed metallic raceways, or jacketed metallic cable assemblies listed for installation in concrete
Exception to (1) and (2): Nonmetallic raceways shall not be used for branch circuits that supply patient care spaces.
- (3) Listed flexible metal raceways and listed metal sheathed cable assemblies, as follows:
 - (4) Where used in listed prefabricated medical headwalls
 - (5) In listed office furnishings
 - (6) Where fished into existing walls or ceilings, not otherwise accessible and not subject to physical damage
 - (7) Where necessary for flexible connection to equipment
 - (8) For equipment that requires a flexible connection due to movement, vibration, or operation
 - (9) Luminaires installed in ceiling structures
- (10) Flexible power cords of appliances or other utilization equipment connected to the EES
- (11) Cables for Class 2 or Class 3 systems permitted in Article 517, Part VI, with or without raceways

Informational Note: See 517.13 for additional grounding requirements in patient care areas.

(D) Capacity of Systems.

The EES shall have the capacity and rating to meet the maximum actual demand likely to be produced by the connected load.

Feeders shall be sized in accordance with 215.4 and Article 120, Part III. The on-site power source(s) required in 517.30 shall have the capacity and rating to meet the demand produced by the load at any given time.

Demand calculations for sizing of the on-site power source(s) shall be based on any of the following:

- (1) Prudent demand factors and historical data
- (2) Connected load
- (3) Feeder calculations
- (4) Any combination of the above

The sizing requirements in 700.5 and 701.5 shall not apply to EES power sources.

(E) Receptacle Identification.

The electrical receptacles or the cover plates for the electrical receptacles supplied from the life safety and critical branches shall have a distinctive color or marking so as to be readily identifiable. [99:6.7.2.2.5(B)]

(F) Feeders from EES Power Source.

A single feeder supplied by an EES power source shall be permitted to supply the EES to the point at which the life safety, critical, and equipment branches are separated. Installation of the transfer equipment shall be permitted at locations other than the EES power source.

(G) Coordination.

Overcurrent protective devices serving the essential electrical system shall be coordinated for the period of time that a fault's duration extends beyond 0.1 second.

Exception No. 1: Coordination shall not be required between transformer primary and secondary overcurrent protective devices where only one overcurrent protective device or set of overcurrent protective devices exists on the transformer secondary.

Exception No. 2: Coordination shall not be required between overcurrent protective devices of the same size (ampere rating) in series.

Informational Note No. 1: The terms *coordination* and *coordinated* as used in this section do not cover the full range of overcurrent conditions.

Informational Note No. 2: See 517.17(C) for information on requirements for the coordination of ground-fault protection.

517.32 Branches Requiring Automatic Connection.

(A) Life Safety and Critical Branch Used in a Type 1 EES.

(1) Division of Patient Care Functions Connected to ESS.

Those functions of patient care depending on lighting or appliances that are connected to the EES shall be divided into the life safety branch and the critical branch, as described in 517.33 and 517.34.

(2) Restoration of Power.

The life safety and critical branches shall be installed and connected to the on-site power source specified in 517.30(A) and 517.30(B) so that all functions specified herein for the life safety and critical branches are automatically restored to operation within 10 seconds after interruption of power. [99:6.7.5.3.1]

517.33 Automatic Connection to Life Safety Branch.

(A) Life Safety Branch.

The life safety branch shall be limited to circuits essential to life safety. [99:6.7.5.1.2.1]

No functions other than those listed in 517.33(A)(1) through 517.33(A)(7) shall be connected to the life safety branch. The life safety branch shall supply power as follows:

- (1) Illumination of means of egress such as lighting required for corridors, passageways, stairways, and landings at exit doors, and all necessary ways of approach to exits
Informational Note: See NFPA 101-2024, *Life Safety Code*, Sections 7.8 and 7.9.
- (2) Exit signs and exit directional signs
Informational Note: See NFPA 101-2024, *Life Safety Code*, Section 7.10.
- (3) Alarm and alerting systems, as follows:
 - (4) Fire alarm systems shall be required.
 - (5) Alarm and alerting systems (other than fire alarm systems) shall be connected to the life safety branch or critical branch. [99: 6.7.5.1.2.3]
 - (6) Alarms shall be required for systems used for the piping of nonflammable medical gases.
 - (7) Mechanical, control, and other accessories required for effective life safety systems operation shall be permitted to be connected to the life safety branch.
- (8) Communications systems for the following:
 - (9) Communications systems, where used for issuing instructions during emergency conditions [99: 6.7.5.1.2.2(3)]
 - (10) Where used, emergency responder radio communication systems (ERRCs)
- (11) Generator set locations, as follows:
 - (12) Task illumination
 - (13) Battery charger for emergency battery-powered lighting unit(s)
 - (14) Select receptacles at the generator set location and essential electrical system transfer switch locations

[99:6.7.5.1.2.2(4)]

(15) Elevator cab lighting, control, communications, and signal systems [99:6.7.5.1.2.2(5)]

(16) Electrically powered doors used for building egress [99:6.7.5.1.2.2(6)]

(B) Illumination of Means of Egress.

Switching arrangements to transfer patient corridor lighting in hospitals from general illumination circuits to night illumination circuits shall be permitted if only one of two circuits can be selected and both circuits cannot be extinguished at the same time.

(C) Generator Set Accessories.

Loads dedicated to a specific generator, including the fuel transfer pump(s), ventilation fans, electrically operated louvers, controls, cooling system, and other generator accessories essential for generator operation, shall be connected to the life safety branch or the output terminals of the generator with overcurrent protective devices. [99:6.7.5.1.2.4]

517.34 Critical Branch.

(A) Task Illumination, Fixed Equipment, and Select Receptacles.

The critical branch shall supply power for task illumination, fixed equipment, select receptacles, and select power circuits serving the following spaces and functions related to patient care:

- (1) Category 1 spaces where deep sedation or general anesthesia is administered, task illumination, select receptacles, and fixed equipment
- (2) Task illumination and select receptacles in the following:
 - (3) Patient care spaces, including infant nurseries, selected acute nursing areas, psychiatric bed areas (omit receptacles), and ward treatment rooms
 - (4) Medication preparation spaces
 - (5) Pharmacy dispensing spaces
 - (6) Nurses' stations — unless adequately lighted by corridor luminaires
- (7) Additional specialized patient care task illumination and receptacles, where needed
- (8) Nurse call systems
- (9) Blood, bone, and tissue banks
- (10) Telecommunications entrance facility, telecommunications equipment rooms, and telecommunication rooms and equipment in these rooms
- (11) Task illumination, select receptacles, and select power circuits for the following areas:
 - (12) Category 1 or 2 spaces with at least one duplex receptacle per patient bed location, and task illumination as required by the governing body of the health care facility.
 - (13) Angiographic labs
 - (14) Cardiac catheterization labs
 - (15) Coronary care units
 - (16) Hemodialysis rooms or areas
 - (17) Emergency room treatment areas (select).
 - (18) Human physiology labs
 - (19) Intensive care units
 - (20) Postoperative recovery rooms (select).
- (21) Clinical IT-network equipment
- (22) Wireless phone and paging equipment for clinical staff communications
- (23) Additional task illumination, receptacles, and select power circuits needed for effective facility operation, including single-phase fractional horsepower motors, which are permitted to be connected to the critical branch

[99:6.7.5.1.3.2]

(B) Switching.

It shall be permitted to control task illumination on the critical branch.

(C) Subdivision of the Critical Branch.

The critical branch shall be permitted to be subdivided into two or more branches.

[99:6.7.5.1.3.1]

Informational Note: It is important to analyze the consequences of supplying an area with only critical branch power when failure occurs between the area and the transfer switch. Some proportion of normal and critical power or critical power from separate transfer switches might be appropriate.

517.35 Equipment Branch Connection to On-Site Source.

The equipment branch shall be installed and connected to the on-site power source such that equipment described in 517.35(A) is automatically restored to operation at appropriate time-lag intervals following the energizing of the life safety and critical branches. [99:6.7.5.1.4.2(A)]

The arrangement of the connection to the on-site power source shall also provide for the subsequent connection of equipment described in 517.35(B). [99:6.7.5.1.4.2(B)]

Exception: For EESs under 150 kVA, deletion of the time-lag intervals feature for delayed automatic connection to the equipment system shall be permitted.

(A) Equipment for Delayed Automatic Connection.

The following equipment shall be permitted to be arranged for delayed-automatic connection to the on-site power source:

- (1) Central suction systems serving medical and surgical functions, including controls, with such suction systems permitted to be placed on the critical branch
- (2) Sump pumps and other equipment required to operate for the safety of major apparatus, including associated control systems and alarms
- (3) Compressed air systems serving medical and surgical functions, including controls, with such air systems permitted to be placed on the critical branch
- (4) Smoke control and stair pressurization systems
- (5) Kitchen hood supply or exhaust systems, or both, if required to operate during a fire in or under the hood
- (6) Supply, return, and exhaust ventilating systems for the following:
 - (7) Airborne infectious/isolation rooms
 - (8) Protective environment rooms
 - (9) Exhaust fans for laboratory fume hoods
 - (10) Nuclear medicine areas where radioactive material is used
 - (11) Ethylene oxide evacuation
 - (12) Anesthetic evacuation

[99:6.7.5.1.4.3(A)]

Where delayed-automatic connection is not appropriate, the ventilation systems specified in 517.35(A)(6) shall be permitted to be placed on the critical branch. [99:6.7.5.1.4.3(B)]

(B) Equipment for Delayed Automatic or Manual Connection.

The following equipment shall be permitted to be arranged for either delayed-automatic or manual connection to the on-site power source:

- (1) Heating equipment used to provide heating for operating, delivery, labor, recovery, intensive care, and coronary care spaces; nurseries; infection/isolation rooms; emergency treatment spaces; and general patient rooms and pressure maintenance (i.e., jockey or make-up) pumps for water-based fire protection systems [99:6.7.5.1.4.4(1)]

Exception: Heating of general patient rooms and infection/isolation rooms during disruption of the normal source shall not be required under any of the following conditions:

- (1) *The outside design temperature is higher than -6.7°C (20°F).*
- (2) *The outside design temperature is lower than -6.7°C (20°F), and where a selected room(s) is provided for the needs of all confined patients, only such room(s) need be heated.*
- (3) *The facility is served by a dual source of normal power.*

Informational Note No. 1: See ASHRAE *Handbook on Fundamentals* (2013) Chapter 24, which shows the outside design temperature is based on the 97.5 percent design values.

Informational Note No. 2: See 517.30(D) for a description of a dual source of normal power.

- (2) Elevator(s) selected to provide service to patient, surgical, obstetrical, and ground floors during interruption of normal power [99:6.7.5.1.4.4(3)]
- (3) Supply, return, and exhaust ventilating systems for surgical and obstetrical delivery suites; intensive care and coronary care spaces; nurseries; and emergency treatment spaces [99:6.7.5.1.4.4(4)]
- (4) Hyperbaric facilities [99:6.7.5.1.4.4(5)]
- (5) Hypobaric facilities [99:6.7.5.1.4.4(6)]
- (6) Automatically operated doors
- (7) Autoclaving equipment, which is permitted to be arranged for either automatic or manual connection to the alternate source [99:6.7.5.1.4.4(7)]
- (8) Controls for equipment listed in 517.35 [99:6.7.5.1.4.4(8)]
- (9) Other selected equipment [99:6.7.5.1.4.4(9)]

517.40 Type 2 Essential Electrical Systems.

Type 2 EESs shall comply with 517.40(A) through 517.40(C).

Informational Note No. 1: Nursing homes and other limited care facilities can contain Category 1 and/or Category 2 patient care spaces, depending on the design and type of care administered in the facility. For Category 1 spaces, see 517.29 through 517.35. For Category 2 spaces not served by Type 1 EESs, see 517.40 through 517.44.

Informational Note No. 2: Type 2 [EESs] are comprised of two separate branches capable of supplying a limited amount of lighting and power service that is considered essential for the protection of life and safety and effective operation of the institution during the time normal electrical service is interrupted for any reason. These two separate branches are the life safety and equipment branches. The number of transfer switches to be used should be based upon reliability, design, and load considerations. Each branch of the essential electrical system should have one or more transfer switches. One transfer switch should be permitted to serve one or more branches in a facility with a maximum demand on the essential electrical system of 150 kVA (120 kW). [99:A.6.7.6.2.1]

(A) Applicability.

The requirements of 517.40(C) through 517.44 shall apply to Type 2 EESs. Type 2 systems shall be permitted to serve Category 2, Category 3, and Category 4 spaces.

Exception: The requirements of 517.40(C) through 517.44 shall not apply to freestanding buildings used as nursing homes and limited care facilities if the following apply:

- (1) Admitting and discharge policies are maintained that preclude the provision of care for any patient or resident who might need to be sustained by electrical life-support equipment.*
- (2) No surgical treatment requiring general anesthesia is offered.*
- (3) An automatic battery-operated system(s) or equipment shall be effective for at least 1½ hours and is otherwise in accordance with 700.12 and is capable of supplying lighting for exit lights, exit corridors, stairways, nursing stations, medical preparation areas, boiler rooms, and communications areas. This system shall also supply power to operate all alarm systems.*

Informational Note: See NFPA 101-2024, *Life Safety Code*.

(B) Category 1 Spaces in Inpatient Hospital Care Facilities.

For those nursing homes and limited care facilities that admit patients who need to be sustained by electrical life-support equipment, the EES from the source to the portion of the facility where such patients are treated shall comply with the requirements of 517.29 through 517.35.

(C) Facilities Contiguous or Located on the Same Site with Hospitals.

Nursing homes and limited care facilities that are contiguous or located on the same site with a hospital shall be permitted to have their EESs supplied by the hospital.

517.41 Required Power Sources.

(A) Independent Power Sources.

EES loads shall be served by two or more independent sources (or sets of sources). One source (or sets of sources) shall be on-site power production equipment, storage components, or a combination sized to supply the entire EES.

Informational Note: An example of a set of sources may be several generators that when combined serve the entire EES.

(B) Location of EES Components.

Electrical system components shall be located to minimize interruptions caused by natural forces common to the area or natural disasters identified in the facility's emergency operations plan. [99:6.2.4.1]

Installations of [the two independent] electrical sources [or sets of sources] shall be located to reduce possible interruption of electrical systems resulting from natural forces and to reduce possible disruption of electrical systems due to internal wiring and equipment failures. [99:6.2.4.2]

Feeders and associated raceways serving [EES] transfer equipment shall be located such that physical separation is provided between each of the electrical system feeders to prevent possible simultaneous interruption. [99:6.2.4.3]

(C) Power Sources for the EES.

Power sources for the EES shall be permitted to be any of those specified in 517.30.

517.42 Essential Electrical Systems.

(A) General.

The [Type 2] essential electrical system shall be divided into the following two branches:

- (1) Life safety branch
- (2) Equipment branch

[99:6.7.6.2.1.2]

The division between the branches shall occur at transfer switches where more than one transfer switch is required. **[99:6.7.2.2.1]**

Informational Note No. 1: Type 2 essential electrical systems are comprised of two separate branches capable of supplying a limited amount of lighting and power service that is considered essential for the protection of life and safety and effective operation of the institution during the time normal electrical service is interrupted for any reason. These two separate branches are the life safety and equipment branches.

[99:A.6.7.6.2.1]

Informational Note No. 2: The number of transfer switches to be used should be based upon reliability, design, and load considerations. Each branch of the essential electrical system should have one or more transfer switches. One transfer switch should be permitted to serve one or more branches in a facility with a maximum demand on the essential electrical system of 150 kVA (120 kW). **[99:A.6.7.6.2.1]**

Informational Note No. 3: See NFPA 99-2024, *Health Care Facilities Code*, 6.7.2.2, for more information.

(B) Transfer Switches.

The number of transfer switches to be used shall be based upon reliability, design, and load considerations. [99:6.7.2.2.3]

Transfer switches shall comply with one of the following:

- (1) Each branch of the essential electrical system shall have one or more transfer switches. [99:6.7.2.2.3.1]
- (2) One transfer switch shall be permitted to serve one or more branches in a facility with a continuous load on the switch of 150 kVA (120 kW) or less. [99:6.7.2.2.3.2]

Informational Note No. 1: See NFPA 99-2024, *Health Care Facilities Code*, 6.7.2.2.4, 6.7.2.2.5, 6.7.2.2.5.15, and 6.7.2.2.7 for more information on transfer switches.

Informational Note No. 2: See Figure Informational Note 517.42(B)(1).

Informational Note No. 3: See Figure Informational Note 517.42(B)(2).

Figure Informational Note 517.42(B)(1) Type 2 EESs (Nursing Home and Limited Health Care Facilities) — Minimum Requirement (Greater Than 150 kVA) for Transfer Switch Arrangement.

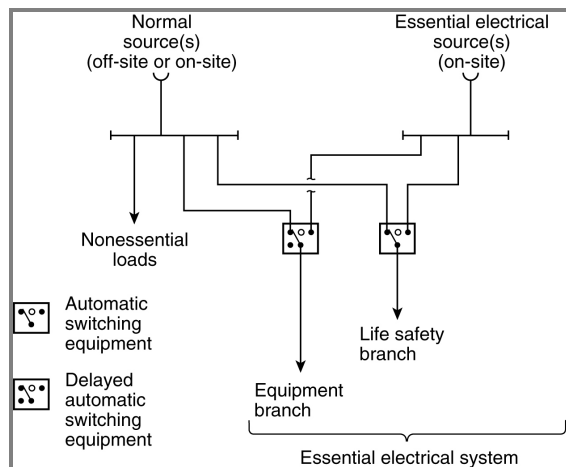
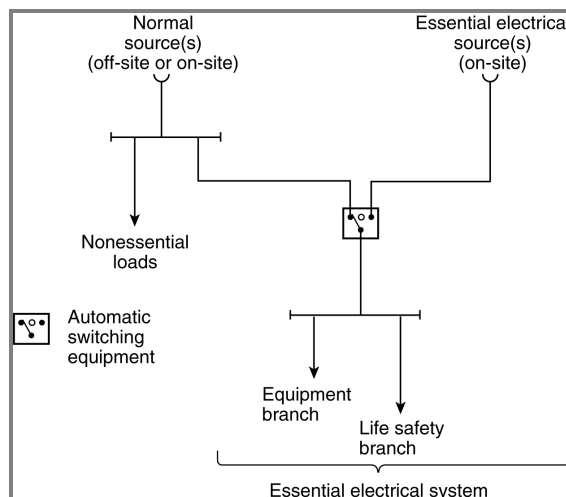

Figure Informational Note 517.42(B)(2) Type 2 EESs (Nursing Home and Limited Health Care Facilities) — Minimum Requirement (150 kVA or Less) for Transfer Switch Arrangement.



(C) Capacity of System.

The essential electrical system shall have capacity to meet the demand for the operation of all functions and equipment to be served by each branch at one time.

(D) Separation from Other Circuits.

The life safety branch and equipment branch shall be kept entirely independent of all other wiring and equipment. [99:6.7.6.3.1]

These circuits shall not enter the same raceways, boxes, or cabinets with other wiring except as follows:

- (1) In transfer switches
- (2) In exit or emergency luminaires supplied from two sources
- (3) In a common junction box attached to exit or emergency luminaires supplied from two sources

(E) Receptacle Identification.

The electrical receptacles or the cover plates for the electrical receptacles supplied from the life safety or equipment branches shall have a distinctive color or marking so as to be readily identifiable. [99:6.7.6.3.2]

Informational Note: If color is used to identify these receptacles, the same color should be used throughout the facility. [99:A.6.7.6.3.2]

(F) Coordination.

Overcurrent protective devices serving the EES shall be coordinated for the period of time that a fault's duration extends beyond 0.1 second.

Exception No. 1: Coordination shall not be required between transformer primary and secondary overcurrent protective devices where only one overcurrent protective device or set of overcurrent protective devices exists on the transformer secondary.

Exception No. 2: Coordination shall not be required between overcurrent protective devices of the same size (ampere rating) in series.

Informational Note No. 1: The terms *coordination* and *coordinated* as used in this section do not cover the full range of overcurrent conditions.

Informational Note No. 2: See 517.17(C) for information on requirements for the coordination of ground-fault protection.

517.43 Automatic Connection to Life Safety Branch.

(A) Life Safety Branch.

The life safety branches shall be installed and connected to the on-site power specified in 517.41 so that all functions specified herein for the life safety branches are automatically restored to operation within 10 seconds after interruption of power. [99:6.7.6.4.1]

No functions other than those listed in 517.43(B)(1) through 517.43(B)(6) shall be connected to the life safety branch. [99:6.7.6.2.1.5(B)]

The life safety branch shall supply power as follows:

- (1) Illumination of means of egress as is necessary for corridors, passageways, stairways, landings, and exit doors and all ways of approach to exits

Informational Note: See NFPA 101-2024, *Life Safety Code*, Sections 7.8 and 7.9.

- (2) Exit signs and exit directional signs

Informational Note: See NFPA 101-2024, *Life Safety Code*, Section 7.10 and NFPA 99-2024, *Health Care Facilities Code*, 6.7.6.2.1.5(2).

- (3) Alarm and alerting systems, including the following:

- (4) Fire alarms

Informational Note No. 1: See NFPA 99-2024, *Health Care Facilities Code*, 6.7.6.2.1.5(3)(a).

- (5) Alarms required for systems used for the piping of nonflammable medical gases

Informational Note No. 2: See NFPA 99-2024, *Health Care Facilities Code*, 6.7.5.1.2.5.

- (6) Communications systems for the following:

- a. Communications systems, where used for issuing instructions during emergency conditions [99:6.7.6.2.1.5(A)(3)]
- b. Emergency responder radio communication systems (ERRCs)

- (7) Task illumination and select receptacles at the generator set location and essential electrical system transfer switch locations

- (8) Elevator cab lighting, control, communications, and signal systems [99:6.7.6.2.1.5(A)(6)]

(B) Illumination of Means of Egress.

Switching arrangement to transfer patient corridor lighting from general illumination circuits shall be permitted if only one of two circuits can be selected and both circuits cannot be extinguished at the same time.

517.44 Connection to Equipment Branch.

The equipment branch shall be installed and connected to the on-site power source such that equipment described in 517.44(B) is automatically restored to operation at appropriate time-lag intervals following the energizing of the life safety branches. [99:6.7.5.1.4.2(A)]

The equipment branch arrangement shall also provide for the additional connection of equipment listed in 517.44(C).

Exception: For essential electrical systems under 150 kVA, deletion of the time-lag intervals feature for delayed automatic connection to the equipment branch shall be permitted.

(A) ac Equipment for Nondelayed Automatic Connection.

Generator accessories including, but not limited to, the transfer fuel pump, electrically operated louvers, and other generator accessories essential for generator operation shall be arranged for automatic connection to the on-site power source. [99:6.7.6.2.1.6(C)]

(B) Delayed Automatic Connections to Equipment Branch.

The following equipment shall be permitted to be connected to the equipment branch and shall be arranged for delayed-automatic connection to the on-site power source:

- (1) Task illumination and select receptacles in the following:
 - (2) Patient care spaces
 - (3) Medication preparation spaces

 - (4) Pharmacy dispensing space
 - (5) Nurses' stations — unless adequately lighted by corridor luminaires
- (6) Supply, return, and exhaust ventilating systems for airborne infectious isolation rooms
- (7) Sump pumps and other equipment required to operate for the safety of major apparatus and associated control systems and alarms
- (8) Smoke control and stair pressurization systems
- (9) Kitchen hood supply or exhaust systems, or both, if required to operate during a fire in or under the hood
- (10) Nurse call systems
- (11) HVAC systems serving the EF, TER, and TR

[99:6.7.6.2.1.6(D)]

(C) Delayed-Automatic or Manual Connection to the Equipment Branch.

The equipment specified in 517.44(C)(1) through 517.44(C)(4) shall be permitted to be connected to the equipment branch and shall be arranged for either delayed-automatic or manual connection to the alternate power source. [99:6.7.6.2.1.6(E)]

(1) Heating Equipment to Provide Heating for General Patient Rooms.

Heating of general patient rooms during disruption of the normal source shall not be required under any of the following conditions:

- (1) The outside design temperature is higher than -6.7°C (20°F).
- (2) The outside design temperature is lower than -6.7°C (20°F) and, where a selected room(s) is provided for the needs of all confined patients, then only such room(s) need be heated.
- (3) The facility is served by a dual source of normal power as described in 517.30(D) Informational Note.

[99:6.7.6.2.1.6(E)(1)]

Informational Note: See ASHRAE *Handbook of Fundamentals* (2021), Chapter 24, which shows the outside design temperature is based on the 97.5 percent design values.

(2) Elevator Service.

In instances where interruptions of power would result in elevators stopping between floors, throw-over facilities shall be provided to allow the temporary operation of any elevator for the release of passengers. [99:6.7.6.2.1.6(E)(2)]

(3) Optional Connections to the Equipment Branch.

Additional illumination, receptacles, and equipment shall be permitted to be connected only to the equipment branch. [99:6.7.6.2.1.6(E)(3)]

(4) Multiple Systems.

Where one switch serves multiple systems as permitted in 517.43, transfer for all loads shall be nondelayed automatic. [99:6.7.6.2.1.6(E)(4)]

Informational Note: See 517.44(A) for elevator cab lighting, control, and signal system requirements. [99:A.6.7.6.2.1.6(E)(2)]

517.45 Essential Electrical Systems for Other Health Care Facilities.

(A) Essential Electrical Distribution.

If required by the governing body, the essential electrical distribution system for Category 3 patient care spaces shall be comprised of an on-site power system capable of supplying a limited amount of lighting and power service for the orderly cessation of procedures during an interruption of power.

Informational Note: See NFPA 99-2024, *Health Care Facilities Code*.

(B) Electrical Life Support Equipment.

Where electrical life support equipment is required, the essential electrical distribution system shall be as described in 517.29 through 517.30.

(C) Category 1 Patient Care Spaces.

Where Category 1 patient care spaces are present, the essential electrical distribution system shall be in accordance with 517.29 through 517.30.

(D) Category 2 Patient Care Spaces.

Where Category 2 patient care spaces are present, the essential electrical distribution system shall be in accordance with 517.40 through 517.45.

Part IV. Inhalation Anesthetizing Locations

517.60 General.

Inhalation anesthetizing locations shall comply with Article 517, Part IV.

Informational Note: See NFPA 99-2024, *Health Care Facilities Code*, for further information regarding safeguards for anesthetizing locations.

517.61 Anesthetizing Location Classification.

Anesthetizing location classifications shall comply with 517.61(A) and 517.61(B).

Informational Note: See 517.20 if either of the anesthetizing locations in 517.61(A) or 517.61(B) is designated a wet procedure location.

(A) Hazardous (Classified) Location.

(1) Use Location.

In a location where flammable anesthetics are employed, the entire area shall be considered to be a Class I, Division 1 location that extends upward to a level 1.52 m (5 ft) above the floor.

Informational Note: The remaining volume up to the structural ceiling is considered to be above a hazardous (classified) location.

(2) Storage Location.

Any room or location in which flammable anesthetics or volatile flammable disinfecting agents are stored shall be considered to be a Class I, Division 1 location from floor to ceiling.

(B) Unclassified Location.

Any inhalation anesthetizing location designated for the exclusive use of nonflammable anesthetizing agents shall be considered to be an unclassified location.

517.62 Wiring and Equipment.

(A) Within Hazardous (Classified) Anesthetizing Locations.

(1) Isolation.

Except as permitted in 517.160, each power circuit within, or partially within, a flammable anesthetizing location as referred to in 517.61 shall be isolated from any distribution system by the use of an isolated power system.

(2) Design and Installation.

Where an isolated power system is utilized, the isolated power equipment shall be listed as isolated power equipment, and the isolated power system shall be designed and installed in accordance with 517.160.

(3) Equipment Operating at More Than 10 Volts.

In hazardous (classified) locations referred to in 517.61, all fixed wiring and equipment and all portable equipment, including lamps and other utilization equipment, operating at more than 10 volts between conductors shall comply with the requirements of 501.1 through 501.25, and 501.100 through 501.150, and 500.30(A) and 500.30(B) for Class I, Division 1 locations. All such equipment shall be specifically approved for the hazardous atmospheres involved.

(4) Extent of Location.

Where a box, fitting, or enclosure is partially, but not entirely, within a hazardous (classified) location(s), the hazardous (classified) location(s) shall be considered to be extended to include the entire box, fitting, or enclosure.

(5) Receptacles and Attachment Plugs.

Receptacles and attachment plugs in a hazardous (classified) location(s) shall be listed for use in Class I, Group C hazardous (classified) locations and shall have provision for the connection of an equipment grounding conductor.

(6) Flexible Cord Type.

Flexible cords used in hazardous (classified) locations for connection to portable utilization equipment, including lamps operating at more than 8 volts between conductors, shall be of a type approved for extra-hard usage in accordance with Table 400.4 and shall include an additional equipment grounding conductor.

(7) Flexible Cord Storage.

A storage device for the flexible cord shall be provided and shall not subject the cord to bending at a radius of less than 75 mm (3 in.).

(B) Above Hazardous (Classified) Anesthetizing Locations.

(1) Wiring Methods.

Wiring above a hazardous (classified) location referred to in 517.61 shall be installed in rigid metal conduit, electrical metallic tubing, intermediate metal conduit, Type MI cable, or Type MC cable that employs a continuous, gas/vaportight metal sheath.

(2) Equipment Enclosure.

Installed equipment that may produce arcs, sparks, or particles of hot metal, such as lamps and lampholders for fixed lighting, cutouts, switches, generators, motors, or other equipment having make-and-break or sliding contacts, shall be of the totally enclosed type or be constructed so as to prevent escape of sparks or hot metal particles.

Exception: Wall-mounted receptacles installed above the hazardous (classified) location in flammable anesthetizing locations shall not be required to be totally enclosed or have openings guarded or screened to prevent dispersion of particles.

(3) Luminaires.

Surgical and other luminaires shall conform to 501.130(B).

Exception No. 1: The surface temperature limitations set forth in 501.130(B)(1) shall not apply.

Exception No. 2: Integral or pendant switches that are located above and cannot be lowered into the hazardous (classified) location(s) shall not be required to be explosionproof.

(4) Seals.

Listed seals shall be provided in conformance with 501.15, and 501.15(A)(4) shall apply to horizontal as well as to vertical boundaries of the defined hazardous (classified) locations.

(5) Receptacles and Attachment Plugs.

Receptacles and attachment plugs located above hazardous (classified) anesthetizing locations shall be listed for hospital use for services of prescribed voltage, frequency, rating, and number of conductors with provision for the connection of the equipment grounding conductor. This requirement shall apply to attachment plugs and receptacles of the 2-pole, 3-wire grounding type for single-phase, 120-volt, nominal, ac service.

(6) 250-Volt Receptacles and Attachment Plugs Rated 50 and 60 Amperes.

Receptacles and attachment plugs rated 250 volts, for connection of 50-ampere and 60-ampere ac medical equipment for use above hazardous (classified) locations, shall be arranged so that the 60-ampere receptacle will accept either the 50-ampere or the 60-ampere plug. Fifty-ampere receptacles shall be designed so as not to accept the 60-ampere attachment plug. The attachment plugs shall be of the 2-pole, 3-wire design with a third contact connecting to the insulated (green or green with yellow stripe) equipment grounding conductor of the electrical system.

(C) Unclassified Anesthetizing Locations.

(1) Wiring Methods.

Wiring serving unclassified locations, as defined in 517.61, shall be installed in a metal raceway system or cable assembly. The metal raceway system or cable armor or sheath assembly shall qualify as an equipment grounding conductor in accordance with 250.118. Type MC and Type MI cable shall have an outer metal armor, sheath, or sheath assembly that is identified as an equipment grounding conductor.

Exception: Pendant receptacle installations that employ listed Type SJO or equivalent hard usage or extra-hard usage, flexible cords suspended not less than 1.8 m (6 ft) from the floor shall not be required to be installed in a metal raceway or cable assembly.

(2) Receptacles and Attachment Plugs.

Receptacles and attachment plugs installed and used in unclassified locations shall be listed "hospital grade" for services of prescribed voltage, frequency, rating, and number of conductors with provision for connection of the equipment grounding conductor. This requirement shall apply to 2-pole, 3-wire grounding type for single-phase, 120-, 208-, or 240-volt, nominal, ac service.

(3) 250-Volt Receptacles and Attachment Plugs Rated 50 Amperes and 60 Amperes.

Receptacles and attachment plugs rated 250 volts, for connection of 50-ampere and 60-ampere ac medical equipment for use in unclassified locations, shall be arranged so that the 60-ampere receptacle will accept either the 50-ampere or the 60-ampere plug. Fifty-ampere receptacles shall be designed so as not to accept the 60-ampere attachment plug. The attachment plugs shall be of the 2-pole, 3-wire design with a third contact connecting to the insulated (green or green with yellow stripe) equipment grounding conductor of the electrical system.

517.63 Grounding.

In any anesthetizing area, all metal raceways and metal-sheathed cables and all normally non-current-carrying conductive portions of fixed electrical equipment shall be connected to an equipment grounding conductor. Grounding and bonding in Class I locations shall comply with 501.30.

Exception: Equipment operating at not more than 10 volts between conductors shall not be required to be connected to an equipment grounding conductor.

517.64 Grounded Power Systems in Anesthetizing Locations.

(A) Battery-Powered Lighting Units.

One or more battery-powered lighting units shall be provided and shall be permitted to be wired to the critical lighting circuit in the area and connected ahead of any local switches.

(B) Branch-Circuit Wiring.

Branch circuits supplying only listed, fixed, therapeutic and diagnostic equipment, permanently installed above the hazardous (classified) location and in unclassified locations, shall be permitted to be supplied from a normal grounded service, single- or three-phase system, provided the following apply:

- (1) Wiring for grounded and isolated circuits does not occupy the same raceway or cable.
- (2) All conductive surfaces of the equipment are connected to an equipment grounding conductor.
- (3) Equipment (except enclosed X-ray tubes and the leads to the tubes) is located at least 2.5 m (8 ft) above the floor or outside the anesthetizing location.
- (4) Switches for the grounded branch circuit are located outside the hazardous (classified) location.

Exception: Sections 517.64(B)(3) and (B)(4) shall not apply in unclassified locations.

(C) Fixed Lighting Branch Circuits.

Branch circuits supplying only fixed lighting shall be permitted to be supplied by a normal grounded service, provided the following apply:

- (1) Such luminaires are located at least 2.5 m (8 ft) above the floor.
- (2) All conductive surfaces of luminaires are connected to an equipment grounding conductor.
- (3) Wiring for circuits supplying power to luminaires does not occupy the same raceway or cable for circuits supplying isolated power.
- (4) Switches are wall-mounted and located above hazardous (classified) locations.

Exception: Sections 517.64(C)(1) and (C)(4) shall not apply in unclassified locations.

(D) Remote-Control Stations.

Wall-mounted remote-control stations for remote-control switches operating at 24 volts or less shall be permitted to be installed in any anesthetizing location.

(E) Location of Isolated Power Systems.

Where an isolated power system is utilized, the isolated power equipment shall be listed as isolated power equipment. Isolated power system equipment and its supply circuit shall be permitted to be located in an anesthetizing location, provided it is installed above a hazardous (classified) location or in an unclassified location.

(F) Circuits in Anesthetizing Locations.

Except as permitted above, each power circuit within, or partially within, a flammable anesthetizing location as referred to in 517.61 shall be isolated from any distribution system supplying other-than-anesthetizing locations.

517.65 Low-Voltage Equipment and Instruments.

(A) Equipment Requirements.

Low-voltage equipment that is frequently in contact with the bodies of persons or has exposed current-carrying elements shall comply with one of the following:

- (1) Operate on an electrical potential of 10 volts or less
- (2) Be approved as intrinsically safe or double-insulated equipment
- (3) Be moisture resistant

(B) Power Supplies.

Power shall be supplied to low-voltage equipment from one of the following:

- (1) An individual portable isolating transformer connected to an isolated power circuit receptacle by means of an appropriate cord and attachment plug
- (2) A common low-voltage isolating transformer installed in an unclassified location
- (3) Individual dry-cell batteries
- (4) Common batteries made up of storage cells located in an unclassified location

Autotransformers shall not be permitted.

(C) Isolated Circuits.

Isolating-type transformers for supplying low-voltage circuits shall have both of the following:

- (1) Approved means for insulating the secondary circuit from the primary circuit
- (2) The core and case connected to an equipment grounding conductor

(D) Controls.

Resistance or impedance devices shall be permitted to control low-voltage equipment but shall not be used to limit the maximum available voltage to the equipment.

(E) Battery-Powered Appliances.

Battery-powered appliances shall not be capable of being charged while in operation unless their charging circuitry incorporates an integral isolating-type transformer.

(F) Receptacles or Attachment Plugs.

Any receptacle or attachment plug used on low-voltage circuits shall be of a type that does not permit interchangeable connection with circuits of higher voltage.

Informational Note: Any interruption of the circuit, even circuits as low as 10 volts, either by any switch or loose or defective connections anywhere in the circuit, may produce a spark that is sufficient to ignite flammable anesthetic agents.

Part V. Diagnostic Imaging and Treatment Equipment

517.70 Applicability.

Diagnostic imaging and treatment equipment shall be installed in accordance with Article 517, Part V.

Informational Note No. 1: Radiation safety and performance requirements of several classes of X-ray equipment are regulated under Public Law 90-602 and are enforced by the Department of Health and Human Services.

Informational Note No. 2: Information on radiation protection by the National Council on Radiation Protection and Measurements is published as *Reports of the National Council on Radiation Protection and Measurement*.

Informational Note No. 3: Examples of diagnostic imaging equipment can include, but are not limited to, the following:

- (1) General radiographic (X-ray) equipment (mobile and fixed)
- (2) General fluoroscopic equipment (mobile and fixed)
- (3) Interventional equipment (mobile and fixed)
- (4) Bone mineral density equipment
- (5) Dental equipment
- (6) Computerized tomography (CT) equipment
- (7) Positron emission tomography (PET) equipment
- (8) Nuclear medicine equipment
- (9) Mammography equipment
- (10) Magnetic resonance (MR) equipment
- (11) Diagnostic ultrasound equipment
- (12) Electrocardiogram equipment

Informational Note No. 4: Examples of treatment equipment can include, but are not limited to, the following:

- (1) Linear accelerators
- (2) Gamma knife
- (3) Cyber knife
- (4) Proton therapy
- (5) Tomotherapy

517.71 Connection to Supply Circuit.

(A) Fixed and Stationary Diagnostic Imaging and Treatment Equipment.

Fixed and stationary diagnostic imaging and treatment equipment shall be connected to the power supply by means of a wiring method complying with applicable requirements of Chapters 1 through 4 of this code, as modified by this article.

Exception: Equipment properly supplied by a branch circuit rated at not over 30 amperes shall be permitted to be supplied through a suitable attachment plug and hard-service cable or cord.

(B) Portable, Mobile, and Transportable Diagnostic Imaging and Treatment Equipment.

Individual branch circuits shall not be required for portable, mobile, and transportable medical diagnostic imaging and treatment equipment requiring a capacity of not over 60 amperes.

(C) Over 1000-Volts ac, 1500 Volts dc, Supply.

Circuits and equipment operated on a supply circuit of over 1000 volts ac, 1500 volts dc, shall comply with Article 495, Parts I through IV.

517.72 Disconnecting Means.

(A) Capacity.

A disconnecting means rated for at least 50 percent of the input required for the momentary rating or 100 percent of the input required for the long-time rating of the diagnostic imaging and treatment equipment, whichever is greater, shall be provided in the supply circuit.

(B) Location.

The disconnecting means shall be operable from a location readily accessible from the control location.

(C) Portable, Mobile, and Transportable Diagnostic Imaging and Treatment Equipment.

For equipment connected to a 120-volt branch circuit of 30 amperes or less, a grounding-type attachment plug and receptacle of proper rating shall be permitted to serve as a disconnecting means.

517.73 Rating of Supply Conductors and Overcurrent Protection.

(A) Branch Circuits.

The ampacity of supply branch-circuit conductors and the current rating of overcurrent protective devices shall not be less than 50 percent of the momentary rating or 100 percent of the long-time rating, whichever is greater.

(B) Feeders.

The ampacity of supply feeders and the current rating of overcurrent protective devices supplying two or more branch circuits supplying diagnostic imaging and treatment equipment shall not be less than 50 percent of the momentary demand rating of the largest unit, plus 25 percent of the momentary demand rating of the next largest unit, plus 10 percent of the momentary demand rating of each additional unit.

Informational Note No. 1: The minimum conductor size for branch and feeder circuits is also governed by voltage regulation requirements. For a specific installation, the manufacturer usually specifies minimum distribution transformer and conductor sizes, rating of disconnecting means, and overcurrent protection.

Informational Note No. 2: The ampacity of the branch-circuit conductors and the ratings of disconnecting means and overcurrent protection for diagnostic imaging and treatment equipment are usually designated by the manufacturer for the specific installation.

517.74 Control Circuit Conductors.

(A) Number of Conductors in Raceway.

The number of control circuit conductors installed in a raceway shall be determined in accordance with 300.19.

(B) Minimum Size of Conductors.

Size 18 AWG or 16 AWG fixture wires in accordance with 724.49 and flexible cords shall be permitted for the control and operating circuits of diagnostic imaging and treatment equipment and auxiliary equipment where protected by not larger than 20-ampere overcurrent protective devices.

517.76 Transformers and Capacitors.

Transformers and capacitors that are part of diagnostic imaging and treatment equipment shall not be required to comply with Articles 450, Parts I and II, and Article 460, Parts I and II.

Capacitors shall be mounted within enclosures of insulating material or grounded metal.

517.77 Installation of Cables with Grounded Shields.

Cables with grounded shields shall be permitted to be installed in cable trays or cable troughs along with control and power supply conductors without the need for barriers to separate the wiring.

517.78 Guarding and Grounding.

(A) High-Voltage Parts.

All high-voltage parts shall be mounted within grounded enclosures. The connection from the high-voltage equipment to other high-voltage components shall be made with high-voltage shielded cables.

(B) Low-Voltage Cables.

Low-voltage cables connecting to oil-filled units that are not completely sealed, such as transformers, condensers, oil coolers, and high-voltage switches, shall have insulation of the oil-resistant type.

(C) Non-Current-Carrying Metal Parts.

Non-current-carrying metal parts of diagnostic imaging and treatment equipment (e.g., controls, tables, transformer tanks, shielded cables) shall be connected to an equipment grounding conductor in accordance with Article 250, Part VII, as modified by 517.13(A) and 517.13(B).

Part VI. Communications, Signaling Systems, Data Systems, Fire Alarm Systems, and Systems Less Than 120 Volts, Nominal

517.80 Patient Care Spaces.

Equivalent insulation and isolation to that required for the electrical distribution systems in patient care areas shall be provided for communications systems, signaling systems, data system circuits, fire alarm systems, and systems less than 120 volts, nominal.

Class 2 and Class 3 signaling and communications systems, Class 2 circuits that transmit power and data to a powered device, and power-limited fire alarm systems shall not be required to comply with the grounding requirements of 517.13, to comply with the mechanical protection requirements of 517.31(C)(3)(5), or to be enclosed in raceways, unless otherwise specified by Chapters 7 or 8 or except as noted for critical and life safety branch powered circuits.

Class 2 lighting circuit cabling fed from critical or life safety branch power shall comply with the mechanical protection requirements of this article.

Exception No. 1: Mechanical protection requirements shall not apply to wiring that does not exceed 1.8 m (6 ft) in length and that terminates at a critical or life safety luminaire or an emergency lighting control device.

Exception No. 2: Mechanical protection requirements shall not apply to locked rooms or locked enclosures that are accessible only to qualified persons.

Informational Note: Locked rooms accessible only to qualified persons include locked telecommunications rooms, locked electrical equipment rooms, or other access-controlled areas.

Secondary circuits of transformer-powered communications or signaling systems shall not be required to be enclosed in raceways unless otherwise specified by Chapters 7 or 8.

[99:6.7.2.2.7]

Informational Note: See ANSI/NEMA C137.3-2017, *American National Standard for Lighting Systems — Minimum Requirements for Installation of Energy Efficient Power over Ethernet (PoE) Lighting Systems*, for information on installation of cables for PoE lighting systems.

517.81 Other-Than-Patient-Care Spaces.

In other-than-patient-care spaces, installations shall be in accordance with other parts of this code.

517.82 Signal Transmission Between Appliances.

(A) General.

Permanently installed signal cabling from an appliance in a patient location to remote appliances shall employ a signal transmission system that prevents hazardous grounding interconnection of the appliances.

Informational Note: See 517.13(A) for additional grounding requirements in patient care spaces.

(B) Common Signal Grounding Wire.

Common signal grounding wires (i.e., the chassis ground for single-ended transmission) shall be permitted to be used between appliances all located within the patient care vicinity, provided the appliances are served from the same reference grounding point.

Part VII. Isolated Power Systems

517.160 Isolated Power Systems.

(A) Installations.

(1) Isolated Power Circuits.

Each isolated power circuit shall be controlled by a switch or circuit breaker that has a disconnecting pole in each isolated circuit conductor to simultaneously disconnect all power. Such isolation shall be accomplished by means of one or more isolation transformers, by means of generator sets, or by means of electrically isolated batteries. Conductors of isolated power circuits shall not be installed in cables, raceways, or other enclosures containing conductors of another system.

(2) Circuit Characteristics.

(a) Circuits supplying primaries of isolating transformers shall operate at not more than 600 volts between conductors and shall be provided with proper overcurrent protection.

(b) The secondary voltage of such transformers shall not exceed 600 volts between conductors of each circuit. All circuits supplied from such secondaries shall be ungrounded and shall have an approved overcurrent protective device of proper ratings in each conductor.

(c) Circuits supplied directly from batteries or from motor generator sets shall be ungrounded and be protected against overcurrent in the same manner as transformer-fed secondary circuits.

(d) If an electrostatic shield is present, it shall be connected to the reference grounding point.

(3) Equipment Location.

The isolating transformers, motor generator sets, batteries and battery chargers, and associated primary or secondary overcurrent protective devices shall not be installed in hazardous (classified) locations. The isolated secondary circuit wiring extending into a hazardous anesthetizing location shall be installed in accordance with 501.10.

(4) Isolation Transformers.

An isolation transformer shall not serve more than one operating room except as covered in 517.160(A)(4)(a) and 517.160(A)(4)(b).

Informational Note: For purposes of this section, anesthetic induction rooms are considered part of the operating room or rooms served by the induction rooms.

(a) *Induction Rooms.* Where an induction room serves more than one operating room, the isolated circuits of the induction room shall be permitted to be supplied from the isolation transformer of any one of the operating rooms served by that induction room.

(b) *Higher Voltages.* Isolation transformers shall be permitted to serve single receptacles in several patient areas where the following apply:

- (3) The receptacles are reserved for supplying power to equipment requiring 150 volts or higher, such as portable X-ray units.
- (4) The receptacles and mating plugs are not interchangeable with the receptacles on the local isolated power system.

(5) Conductor Identification.

The isolated circuit conductors shall be identified as follows:

- (1) Isolated Conductor No. 1 — Orange with at least one distinctive colored stripe other than white, green, or gray along the entire length of the conductor
- (2) Isolated Conductor No. 2 — Brown with at least one distinctive colored stripe other than white, green, or gray along the entire length of the conductor

For 3-phase systems, the third conductor shall be identified as yellow with at least one distinctive colored stripe other than white, green, or gray along the entire length of the conductor. Where isolated circuit conductors supply 125-volt, single-phase, 15- and 20-ampere receptacles, the striped orange conductor(s) shall be connected to the terminal(s) on the receptacles that are identified in accordance with 200.10(B) for connection to the grounded circuit conductor.

(6) Wire-Pulling Compounds.

Wire-pulling compounds that increase the dielectric constant shall not be used on the secondary conductors of the isolated power supply.

Informational Note No. 1: It is desirable to limit the size of the isolation transformer to 10 kVA or less and to use conductor insulation with low leakage to meet impedance requirements.

Informational Note No. 2: Minimizing the length of branch-circuit conductors and using conductor insulations with a dielectric constant less than 3.5 and insulation resistance constant greater than 6100 megohm-meters (20,000 megohm-feet) at 16°C (60°F) reduces leakage from line to ground, reducing the hazard current.

(B) Line Isolation Monitor.

Line isolation monitor (LIM) circuits shall be tested after installation and prior to being placed in service.

Informational Note: See NFPA 99-2024, *Health Care Facilities Code*, Section 6.3.3.3.2.

(1) Characteristics.

In addition to the usual control and overcurrent protective devices, each isolated power system shall be provided with a listed continually operating LIM that indicates total hazard current.

(a) The LIM shall be designed such that a green signal lamp, conspicuously visible to persons in each area served by the isolated power system, remains lighted when the system is adequately isolated from ground.

(b) An adjacent red signal lamp and an audible warning signal (remote if desired) shall be energized when the total hazard current (consisting of possible resistive and capacitive leakage currents) from either isolated conductor to ground reaches a threshold value of 5 mA under nominal line voltage conditions.

(c) The LIM shall not alarm for a fault hazard of less than 3.7 mA or for a total hazard current of less than 5 mA.

Exception: A system shall be permitted to be designed to operate at a lower threshold value of total hazard current. A LIM for such a system shall be permitted to be approved, with the provision that the fault hazard current shall be permitted to be reduced but not to less than 35 percent of the corresponding threshold value of the total hazard current, and the monitor hazard current is to be correspondingly reduced to not more than 50 percent of the alarm threshold value of the total hazard current.

(2) Impedance.

The LIM shall be designed to have sufficient internal impedance such that, when properly connected to the isolated system, the maximum internal current that can flow through the LIM, when any point of the isolated system is grounded, shall be 1 mA.

Exception: The LIM shall be permitted to be a low-impedance type such that the current through the LIM, when any point of the isolated system is grounded, will not exceed twice the alarm threshold value for a period not exceeding 5 milliseconds.

Informational Note: Reduction of the monitor hazard current, if this reduction results in an increased “not alarm” threshold value for the fault hazard current, will increase circuit capacity.

(3) Ammeter.

An ammeter calibrated in the total hazard current of the system (contribution of the fault hazard current plus monitor hazard current) shall be mounted in a plainly visible place on the LIM with the “alarm on” zone at approximately the center of the scale.

Exception: The LIM shall be permitted to be a composite unit, with a sensing section cabled to a separate display panel section on which the alarm or test functions are located.

Informational Note: It is desirable to locate the ammeter so that it is conspicuously visible to persons in the anesthetizing location.

Statement of Problem and Substantiation for Public Comment

FOR THE SAKE OF CLARITY AND FUNCTIONALITY CAN WE PLEASE START ART. 517 SEPARATE FROM THE DIAGRAMS FROM ART. 516. ART. 517 IS HEADERED AND IMMEDIATELY FOLLOWED BY FIGURES 516.29(1), 516.29(2), 516.29(3), 516.29(4) AND FIGURE 516.35 ON SEVERAL PAGES. THIS FEELS MESSY AND POSSIBLY MAY LEAD TO MISINTERPERATATION OF ART. 516 DUE TO NOT LOCATING ILLUSTRATED FIGURES AS WELL AS NOT BEING CLEAR ON THE START OF ART. 517.

Related Item

- pi

Submitter Information Verification

Submitter Full Name: Joseph Frank

Organization: Christenson Electric Inc.

Street Address:

City:

State:

Zip:

Submittal Date: Wed Aug 07 19:33:40 EDT 2024

Committee: NEC-P15



Public Comment No. 668-NFPA 70-2024 [Section No. 517.6]

517.6 Patient Care–Related Electrical Equipment.

The reconditioning requirements of this code shall not apply to patient care–related electrical equipment.

Informational Note No. 1: Patient care–related electrical equipment is differentiated from electrical equipment as described in 110.21(A)(2).

Informational Note No. 2: If patient care–related electrical equipment is relocated, it is expected to be recommissioned or recertified in accordance with the U.S. *Federal Food, Drug, and Cosmetic Act (FDCA)*.

Informational Note No. 3: *Patient care–related electrical equipment* is defined in NFPA 99-2024, *Health Care Facilities Code*, 3.3.144, as an electrical equipment appliance that is intended to be used for diagnostic, therapeutic, or monitoring purposes in a patient care vicinity.

Additional Proposed Changes

<u>File Name</u>	<u>Description</u>	<u>Approved</u>
CN_369.pdf		

Statement of Problem and Substantiation for Public Comment

NOTE: The following CC Note No. 369 appeared in the First Draft Report on First Revision No. 8870.

The reconditioning requirements shall be moved to 517.3 in accordance with the NEC® Style Manual Section 2.2.1. and must detail what is permitted to be reconditioned, and what is not permitted to be reconditioned. In addition, for consistency in the document and to comply with NEC Style Manual Section 2.2.1. the Correlating Committee directs CMP-15 to review the language used for reconditioned equipment base on the Correlating Committee Usability Task Group’s recommended format:

XXX.3 Reconditioned Equipment

(A) Permitted to be Installed

The installation of the following reconditioned equipment shall be permitted.

(1) List item one

(2) List item two

(B) Not Permitted to be Installed

The installation of the following reconditioned equipment shall not be permitted.

(1) List item one

(2) List item two

(if only a single permitted use)

XXX.3 Reconditioned Equipment

The installation of reconditioned (item) shall be permitted.

(if only a single not permitted use)

XXX.3 Reconditioned Equipment

The installation of reconditioned (item) shall not be permitted

The Informational Note No. 3 shall be reviewed for compliance with 2.1.10.3 for informational note structure. In addition, if a definition is needed in this document, that definition shall appear in Article 100 in accordance with 2.1.2.2.

Related Item

- First Revision No. 8870

Submitter Information Verification

Submitter Full Name: CC Notes

Organization: NEC Correlating Committee

Street Address:

City:

State:

Zip:

Submittal Date: Fri Aug 02 10:32:04 EDT 2024

Committee: NEC-P15



Correlating Committee Note No. 369-NFPA 70-2024 [Section No. 517.6]

Submitter Information Verification

Committee: NEC-AAC

Submittal Date: Fri May 10 10:08:02 EDT 2024

Committee Statement

Committee Statement: The reconditioning requirements shall be moved to 517.3 in accordance with the NEC® Style Manual Section 2.2.1 and must detail what is permitted to be reconditioned, and what is not permitted to be reconditioned. In addition, for consistency in the document and to comply with NEC Style Manual Section 2.2.1, the Correlating Committee directs CMP-15 to review the language used for reconditioned equipment based on the Correlating Committee Usability Task Group's recommended format:

XXX.3 Reconditioned Equipment

(A) Permitted to be Installed

The installation of the following reconditioned equipment shall be permitted.

(1) List item one

(2) List item two

(B) Not Permitted to be Installed

The installation of the following reconditioned equipment shall not be permitted.

(1) List item one

(2) List item two

(if only a single permitted use)

XXX.3 Reconditioned Equipment

The installation of reconditioned (item) shall be permitted.

(if only a single not permitted use)

XXX.3 Reconditioned Equipment

The installation of reconditioned (item) shall not be permitted

The Informational Note No. 3 shall be reviewed for compliance with 2.1.10.3 for informational note structure. In addition, if a definition is needed in this document, that definition shall appear in Article 100 in accordance with 2.1.2.2.

Ballot Results

✔ This item has passed ballot

12 Eligible Voters

1 Not Returned

11 Affirmative All

0 Affirmative with Comments

0 Negative with Comments

0 Abstention

Not Returned

McDaniel, Roger D.

Affirmative All

Ayer, Lawrence S.

Bowmer, Trevor N.

Hickman, Palmer L.

Holub, Richard A.

Jackson, Peter D.

Kendall, David H.

Manche, Alan

Osborne, Robert D.

Porter, Christine T.

Schultheis, Timothy James

Williams, David A.



Public Comment No. 777-NFPA 70-2024 [Section No. 517.6]

517.6 Patient Care–Related Electrical Equipment.

The reconditioning requirements of this code shall not apply to patient care–related electrical equipment.

Informational Note No. 1: Patient care–related electrical equipment is differentiated from electrical equipment as described in 110.21(A)(2).

Informational Note No. 2: If patient care–related electrical equipment is relocated, it is expected to be recommissioned or recertified in accordance with the U.S. *Federal Food, Drug, and Cosmetic Act (FDCA)*.

Informational Note No. 3: - ~~Patient care–related electrical equipment is defined in NFPA 99-2024, *Health Care Facilities Code*, 3.3.144, as an electrical equipment appliance that is intended to be used for diagnostic, therapeutic, or monitoring purposes in a patient care vicinity. Article 100 contains the definition of Patient Care-Related Electrical Equipment.~~

Statement of Problem and Substantiation for Public Comment

Why would you tell me to go read a different book when this book has the definition you are discussing? If we don't want people to read the Article 100 definition, delete the definition! Don't put it in the code and then pretend it isn't there.

Related Item

- FR 8870

Submitter Information Verification

Submitter Full Name: Ryan Jackson

Organization: Self-employed

Street Address:

City:

State:

Zip:

Submittal Date: Mon Aug 05 10:52:11 EDT 2024

Committee: NEC-P15



Public Comment No. 779-NFPA 70-2024 [Section No. 517.7(A)]

~~(A) Risk Categories:~~

~~All activities, as well as systems or equipment that are new or altered, shall be designed and installed to meet Category 1 through Category 4 requirements, as detailed in this code. [99: 4.1]~~

~~Activities, systems, and equipment shall be permitted to be designed and installed to a higher risk category. [99: 4.1.5]~~

~~(1) Category 1:~~

~~Activities, systems, or equipment whose failure is likely to cause major injury or death of patients, staff, or visitors shall be designed and installed to meet Category 1 requirements, as detailed in this code. [99: 4.1.1]~~

~~(2) Category 2:~~

~~Activities, systems, or equipment whose failure is likely to cause minor injury of patients, staff, or visitors shall be designed and installed to meet Category 2 requirements, as detailed in this code. [99: 4.1.2]~~

~~(3) Category 3:~~

~~Activities, systems, or equipment whose failure is not likely to cause injury of patients, staff, or visitors shall be designed and installed to meet Category 3 requirements, as detailed in this code. [99: 4.1.3]~~

~~(4) Category 4:~~

~~Activities, systems, or equipment whose failure would have no impact on patient care shall be designed and installed to meet Category 4 requirements, as detailed in this code. [99: 4.1.4]~~

~~Informational Note No. 1: Major injury can include the following:~~

- ~~(1) Any amputation~~
- ~~(2) Loss of the sight of an eye (whether temporary or permanent)~~
- ~~(3) Chemical or hot metal burn to the eye or any penetrating injury to the eye~~
- ~~(4) Any injury that results in electric shock and electric burns leading to unconsciousness and that requires resuscitation or admittance to a hospital for 24 hours or more~~
- ~~(5) Any other injury leading to hypothermia, heat induced illness, or unconsciousness requiring resuscitation or admittance to a hospital for 24 hours or more~~
- ~~(6) Loss of consciousness caused by asphyxia or lack of oxygen or exposure to a biological agent or harmful substance~~
- ~~(7) Absorption of any substance by inhalation, skin, or ingestion causing loss of consciousness or acute illness requiring medical treatment~~
- ~~(8) Acute illness requiring medical treatment where there is reason to believe the exposure was to biological agents, its toxins, or infected materials~~

~~[99: A.4.1.1]~~

~~Informational Note No. 2: A minor injury means not serious or involving risk of life. [99: A.4.1.2]~~

Statement of Problem and Substantiation for Public Comment

According to 90.4(A), the NEC is intended to be enforceable by governmental bodies that have jurisdiction over electrical installations. This new section is filled with requirements that are not enforceable. How, exactly, is an electrical inspector supposed to enforce an "activity" in (A)? How do I enforce the requirement that a governing body to perform a risk assessment? And why would I have to tell the governing body that they must establish the "process and operations" for their own facility???

Who else is going to do it?
These requirements make sense in NFPA 99 when the AHJ is not an electrical inspector or Code Official. They do not make sense in this document.

Related Item

- FR 8897

Submitter Information Verification

Submitter Full Name: Ryan Jackson

Organization: Self-employed

Street Address:

City:

State:

Zip:

Submittal Date: Mon Aug 05 11:02:41 EDT 2024

Committee: NEC-P15



Public Comment No. 667-NFPA 70-2024 [Section No. 517.7(B)]

(B) Risk Assessment.

The health care facility's governing body shall establish the processes and operations that are planned for the health care facility. [99:4.2.1]

The governing body shall conduct risk assessments and shall determine risk categories based on the character of the processes and operations conducted in the health care facility. [99:4.2.1.1]

Risk categories shall be classified by the health care facility's governing body by following and documenting a defined risk assessment procedure. [99:4.2.2]

Where required by the authority having jurisdiction, the risk assessment shall be provided to the authority having jurisdiction for review based on the character of the processes and operations conducted in the health care facility. [99:4.2.2.1]

A documented risk assessment shall not be required where Category 1 is selected. [99:4.2.3]

Informational Note: See ISO/IEC 31010-2019, *Risk Management — Risk Assessment Techniques*; NFPA 551-2022, *Guide for the Evaluation of Fire Risk Assessments*; SEMI S10-0307E, *Safety Guideline for Risk Assessment and Risk Evaluation Process*; or SFPE's *Engineering Guide to Fire Risk Assessment* (2006) for information and guidance on risk assessment procedures. The results of the assessment procedure should be documented and records retained.

[99:A.4.2]

Additional Proposed Changes

<u>File Name</u>	<u>Description</u>	<u>Approved</u>
CN_368.pdf		

Statement of Problem and Substantiation for Public Comment

NOTE: The following CC Note No. 368 appeared in the First Draft Report on First Revision No. 8897.

CMP 15 shall review the content of 517.7(B) with regard to whether requirements on determining risk categories in a health care facility is within the scope of the NEC®. The information provided in this section may be more appropriately covered as informational notes. Defined terms are required to be located in Article 100.

Furthermore, 517.7(A) Informational Note No. 2 and 517.7(B) Informational Note shall both be reviewed for compliance with NEC® Style Manual 2.1.10.2 relative to making recommendations or including requirements in an informational note.

Related Item

- First Revision No. 8897

Submitter Information Verification

Submitter Full Name: CC Notes

Organization: NEC Correlating Committee

Street Address:

City:

State:

Zip:

Submittal Date: Fri Aug 02 10:20:41 EDT 2024

Committee: NEC-P15



Correlating Committee Note No. 368-NFPA 70-2024 [New Section after 517.6]

Submitter Information Verification

Committee: NEC-AAC

Submittal Date: Fri May 10 10:02:46 EDT 2024

Committee Statement

Committee Statement: CMP 15 shall review the content of 517.7(B) with regard to whether requirements on determining risk categories in a health care facility is within the scope of the NEC®. The information provided in this section may be more appropriately covered as informational notes. Defined terms are required to be located in Article 100.

Furthermore, 517.7(A) Informational Note No. 2 and 517.7(B) Informational Note shall both be reviewed for compliance with NEC® Style Manual 2.1.10.2 relative to making recommendations or including requirements in an informational note.

First Revision No. 8897-NFPA 70-2024 [New Section after 517.6]

Ballot Results

✓ **This item has passed ballot**

12 Eligible Voters

1 Not Returned

11 Affirmative All

0 Affirmative with Comments

0 Negative with Comments

0 Abstention

Not Returned

McDaniel, Roger D.

Affirmative All

Ayer, Lawrence S.

Bowmer, Trevor N.

Hickman, Palmer L.

Holub, Richard A.

Jackson, Peter D.

Kendall, David H.

Manche, Alan

Osborne, Robert D.

Porter, Christine T.

Schultheis, Timothy James

Williams, David A.



Public Comment No. 669-NFPA 70-2024 [Section No. 517.10(B)]

(B) Not Covered.

Article 517, Part II, shall not apply to the following:

- (1) Spaces not intended for direct patient care
- (2) Spaces of nursing homes and limited care facilities wired in accordance with Chapters 1 through 4 of this code where these spaces are used exclusively as patient sleeping rooms, as determined by the health care facility's governing body

Informational Note No. 1: See 406.26(5) for receptacles located in health care facility business offices, corridors, and waiting rooms that are required to be tamper resistant.

Informational Note No. 2: See 210.12(D) for branch circuits supplying outlets and receptacles located in patient sleeping rooms in nursing homes and limited care facilities that are connected to arc-fault circuit-interrupter circuits.

- (3) Spaces used exclusively for any of the following purposes:
 - a. Intramuscular (IM), subcutaneous (SC), and intradermal (ID) injections (immunizations)
 - b. Psychiatry and psychotherapy
 - c. Alternative medicine
 - d. Optometry
 - e. Pharmacy services not contiguous to health care facilities

Informational Note No. 3: See NFPA 101-2024, *Life Safety Code*.

Informational Note No. 4: Intravenous (IV) infusions and transfusions, epidural infusions, and intraosseous (OS) injections are not considered to be intramuscular (IM), subcutaneous (SC), or intradermal (ID) injections, and are considered medical procedures accompanied by greater patient risk. IV infusions and transfusions are not considered to be alternative medicine.

Informational Note No. 5: See 517.8 for definitions of patient care space categories.

Informational Note No. 6: Spaces that provide direct patient care may need to meet the grounding and bonding requirements of this section when procedures are performed that provide a direct electrical pathway to the heart. NFPA 99-2024, *Health Care Facilities Code*, 3.3.43, defines direct electrical pathway to the heart as an externalized conductive pathway, insulated except at its ends, one end of which is in direct contact with heart muscle while the other is outside the body and is accessible for inadvertent or intentional contact with grounded objects or energized, ground-referenced sources. Electrodes, such as those used for pacing the heart, and catheters filled with conductive fluids are examples of direct electrical pathways to the heart.

Additional Proposed Changes

<u>File Name</u>	<u>Description</u>	<u>Approved</u>
CN_370.pdf		

Statement of Problem and Substantiation for Public Comment

NOTE: The following CC Note No. 370 appeared in the First Draft Report on First Revision No. 8900.

Informational Note No. 4 shall be reviewed in accordance with the NEC® Style Manual Section 2.1.10.2 relative to making interpretations.

Informational Note No. 5 shall be reviewed in respect to defined terms being located in Article 100 and FR-8897 (Style Manual Section 2.1.2.2 for location of defined terms). There is no 517.8, so this informational note, at a minimum, must change to refer to 517.7, but may need to refer to the defined terms in Article 100 instead.

Informational Note No. 6 shall be reviewed for structure in accordance with Style Manual 2.1.10.3, and if a definition is required in this document, it shall be located in Article 100 as required by 2.1.2.2.

Informational Note No. 6 includes a pointer to NFPA 99 for the definition of “Direct Electrical Pathway to the Heart”, and then provides that definition. If this definition is required for application of this section, it shall be located in Article 100 in accordance with 2.1.2.2 of the NEC® Style Manual. Additionally, this informational note appears to have a requirement in it which should be written in enforceable text rather than an informational note. In addition, this informational note should be reviewed vs. NEC® Style Manual 2.1.10.2 relative to making interpretations.

Related Item

- First Revision No. 8900

Submitter Information Verification

Submitter Full Name: CC Notes

Organization: NEC Correlating Committee

Street Address:

City:

State:

Zip:

Submittal Date: Fri Aug 02 10:33:45 EDT 2024

Committee: NEC-P15



Correlating Committee Note No. 370-NFPA 70-2024 [Section No. 517.10(B)]

Submitter Information Verification

Committee: NEC-AAC

Submittal Date: Fri May 10 10:09:35 EDT 2024

Committee Statement

Committee Statement: Informational Note No. 4 shall be reviewed in accordance with the NEC® Style Manual Section 2.1.10.2 relative to making interpretations.

Informational Note No. 5 shall be reviewed in respect to defined terms being located in Article 100 and FR-8897 (Style Manual Section 2.1.2.2 for location of defined terms). There is no 517.8, so this informational note, at a minimum, must change to refer to 517.7, but may need to refer to the defined terms in Article 100 instead.

Informational Note No. 6 shall be reviewed for structure in accordance with Style Manual 2.1.10.3, and if a definition is required in this document, it shall be located in Article 100 as required by 2.1.2.2.

Informational Note No. 6 includes a pointer to NFPA 99 for the definition of “Direct Electrical Pathway to the Heart”, and then provides that definition. If this definition is required for application of this section, it shall be located in Article 100 in accordance with 2.1.2.2 of the NEC® Style Manual. Additionally, this informational note appears to have a requirement in it which should be written in enforceable text rather than an informational note. In addition, this informational note should be reviewed vs. NEC® Style Manual 2.1.10.2 relative to making interpretations.

First Revision No. 8900-NFPA 70-2024 [Section No. 517.10(B)]

Ballot Results

✔ **This item has passed ballot**

12 Eligible Voters

1 Not Returned

11 Affirmative All

0 Affirmative with Comments

0 Negative with Comments

0 Abstention

Not Returned

McDaniel, Roger D.

Affirmative All

Ayer, Lawrence S.

Bowmer, Trevor N.

Hickman, Palmer L.

Holub, Richard A.

Jackson, Peter D.

Kendall, David H.

Manche, Alan

Osborne, Robert D.

Porter, Christine T.

Schultheis, Timothy James

Williams, David A.



Public Comment No. 783-NFPA 70-2024 [Section No. 517.10(B)]

(B) Not Covered.

Article 517, Part II, shall not apply to the following:

- (1) Spaces not intended for direct patient care
- (2) Spaces of nursing homes and limited care facilities wired in accordance with Chapters 1 through 4 of this code where these spaces are used exclusively as patient sleeping rooms, as determined by the health care facility's governing body

Informational Note No. 1: See 406.26(5) for receptacles located in health care facility business offices, corridors, and waiting rooms that are required to be tamper resistant.

Informational Note No. 2: See 210.12(D) for branch circuits supplying outlets and receptacles located in patient sleeping rooms in nursing homes and limited care facilities that are connected to arc-fault circuit-interrupter circuits.

- (3) Spaces used exclusively for any of the following purposes:
 - (4) Intramuscular (IM), subcutaneous (SC), and intradermal (ID) injections (immunizations)
 - (5) Psychiatry and psychotherapy
 - (6) Alternative medicine
 - (7) Optometry
 - (8) Pharmacy services not contiguous to health care facilities

Informational Note No. 3: See NFPA 101-2024, *Life Safety Code*.

Informational Note No. 4: Intravenous (IV) infusions and transfusions, epidural infusions, and intraosseous (OS) injections are not considered to be intramuscular (IM), subcutaneous (SC), or intradermal (ID) injections, and are considered medical procedures accompanied by greater patient risk. IV infusions and transfusions are not considered to be alternative medicine.

Informational Note No. 5: See 517.8 for definitions of patient care space categories.

~~Informational Note No. 6: Spaces that provide direct patient care may need to meet the grounding and bonding requirements of this section when procedures are performed that provide a direct electrical pathway to the heart. NFPA 99-2024, *Health Care Facilities Code*, 3.3.43, defines direct electrical pathway to the heart as an externalized conductive pathway, insulated except at its ends, one end of which is in direct contact with heart muscle while the other is outside the body and is accessible for inadvertent or intentional contact with grounded objects or energized, ground-referenced sources. Electrodes, such as those used for pacing the heart, and catheters filled with conductive fluids are examples of direct electrical pathways to the heart.~~

Statement of Problem and Substantiation for Public Comment

If this Informational Note has to stay, it should at least refer to the Article "Part" not "this section." This section does not contain any requirements whatsoever, grounding/bonding or otherwise. I question the need for the note at all, however, because 517.13 is not contingent on the type of patient care

performed, whether it have a direct electrical pathway to the heart or not. This note is particularly problematic as it acts as though 517.13 is optional by saying that certain spaces "may" need to meet the requirements. Are you insinuating that only invasive procedures with a direct electrical pathway to the heart need to comply? If that is really the intent, please change 517.13 to indicate that fact.

Related Item

- FR 8900

Submitter Information Verification

Submitter Full Name: Ryan Jackson

Organization: Self-employed

Street Address:

City:

State:

Zip:

Submittal Date: Mon Aug 05 11:12:44 EDT 2024

Committee: NEC-P15



Public Comment No. 679-NFPA 70-2024 [Section No. 517.13(A)]

(A) Wiring Methods.

All branch circuits serving patient care spaces shall be provided with an effective ground-fault current path by installation in a metal raceway system or a cable having a metallic armor or sheath assembly. The metal raceway system, metallic cable armor, or sheath assembly shall itself qualify as an equipment grounding conductor in accordance with 250.118.

Informational Note: A metal raceway system includes outlet boxes, device boxes, junction boxes, and other wiring enclosures.

Additional Proposed Changes

<u>File Name</u>	<u>Description</u>	<u>Approved</u>
CN_380.pdf		

Statement of Problem and Substantiation for Public Comment

NOTE: The following CC Note No. 380 appeared in the First Draft Report on First Revision No. 8940.

CMP 15 should consider whether this informational note is making an interpretation that should be included as part of the requirement.

Related Item

- First Revision No. 8940

Submitter Information Verification

Submitter Full Name: CC Notes

Organization: NEC Correlating Committee

Street Address:

City:

State:

Zip:

Submittal Date: Fri Aug 02 11:00:06 EDT 2024

Committee: NEC-P15



Correlating Committee Note No. 380-NFPA 70-2024 [Section No. 517.13(A)]

Submitter Information Verification

Committee: NEC-AAC

Submittal Date: Fri May 10 10:42:21 EDT 2024

Committee Statement

Committee Statement: CMP 15 should consider whether this informational note is making an interpretation that should be included as part of the requirement.

First Revision No. 8940-NFPA 70-2024 [Section No. 517.13(A)]

Ballot Results

✔ **This item has passed ballot**

12 Eligible Voters

1 Not Returned

11 Affirmative All

0 Affirmative with Comments

0 Negative with Comments

0 Abstention

Not Returned

McDaniel, Roger D.

Affirmative All

Ayer, Lawrence S.

Bowmer, Trevor N.

Hickman, Palmer L.

Holub, Richard A.

Jackson, Peter D.

Kendall, David H.

Manche, Alan

Osborne, Robert D.

Porter, Christine T.

Schultheis, Timothy James

Williams, David A.



Public Comment No. 1786-NFPA 70-2024 [New Section after 517.14]

TITLE OF NEW CONTENT

517.15 Multiwire Branch Circuits

The branch circuit serving life safety lighting and power circuits shall not be part of a multiwire branch circuit.

Statement of Problem and Substantiation for Public Comment

FR-8982 proposes to remove the requirement to comply with Article 700, which would result in the loss of requirement to disallow multiwire branch circuits for the life safety branch circuit wiring. This P.C. propose to add this requirement into 517. The text proposed to be added here is copied from 700.19 with revisions from "emergency lighting and power circuits" to "Life safety lighting and power circuits" to match branch for hospitals that matches the emergency branch in non-healthcare buildings.

Related Item

- FR-8982

Submitter Information Verification

Submitter Full Name: Jamie Schnick
Organization: HCAI/OSHPD
Affiliation: CA Department of Health Care Access and Information/Office of Hospital Planning and Development
Street Address:
City:
State:
Zip:
Submittal Date: Tue Aug 27 11:25:06 EDT 2024
Committee: NEC-P15



Public Comment No. 1766-NFPA 70-2024 [Section No. 517.17(A)]

(A) Applicability.

The requirements of 517.17 shall apply to buildings or portions of buildings containing health care facilities with Category 1 spaces or utilizing electrical life-support equipment, and buildings that provide the required essential utilities or services for the operation of Category 1 spaces or electrical life-support equipment. Requirements for Ground Fault Protection of Equipment, as specified in 230.95, and 215.10, shall not apply for either of the following:

- (1) For fused disconnects, where the available fault current, at the fused disconnect, is 10,000 amperes or greater, if the fuses have a clearing time of 0.07 seconds or less at the lower of the calculated minimum available arcing current or 38% of the available fault current, or if the disconnect switch complies with Section 240.67(B)(1), 240.67(B)(3), or 240.67(B)(4), and is set to operate at the lower of the calculated minimum arcing current or 38% of the available fault current, or
- (2) For circuit breakers, where the available fault current, at the circuit breaker, is 10,000 amperes or greater, if the circuit breaker complies with Section 240.87(B)(2), 240.87(B)(4), 240.87(B)(5), or 240.87(B)(6), and is set to operate at the lower of the calculated minimum arcing current or 38% of the available fault current.

Additional Proposed Changes

<u>File Name</u>	<u>Description</u>	<u>Approved</u>
Figure_1_for_Public_Comment_on_517.17.docx	Figure 1 for Public Comment on 517.17	

Statement of Problem and Substantiation for Public Comment

BACKGROUND:

We can now accurately calculate the minimum three-phase arcing current, and the minimum sustainable line-to-ground arcing current, for a high impedance arcing fault. Knowing these currents, we can determine whether or not the arc energy reduction methods in List Items 1 and 2 will operate at, or below, those calculated values. If they do operate at or below those levels, the equipment damage will be just a small percentage of that allowed by the GFPE requirements of 230.95. This applies to all available fault currents of 10,000 amperes or greater.

A requirement (230.95) for ground fault protection of equipment (GFPE) was added to the 1971 NEC® because 480/277 volt, solidly grounded wye services, protected by 1000 ampere and larger overcurrent protective devices, were burning down due to arcing ground faults. 208/120 volt services and those services protected by smaller overcurrent protective devices were not burning down, so they weren't included in the new GFPE requirement.

Over many Code cycles, GFPE requirements were also added for branch circuits (210.13), feeders (215.10), and equipment (240.13). In all cases, the intent was to limit, not eliminate, damage to the switchboard, switchgear, panelboard or equipment being supplied by the 1000 ampere and larger overcurrent protective device.

PRESENT DAY:

The electrical industry has evolved considerably since those early GFPE requirements were introduced. In those years, J. R. Dunki-Jacobs, Harris I. Stanback, and R. H. Kaufman authored numerous ground-breaking papers on arcing ground faults and the need for ground fault protection. They accomplished a great deal that has prevented multitudes of equipment burndowns. Their determination that the minimum sustainable line-to-ground arcing fault on a 480/277 volt system was 38% of the available bolted fault current is very close to the values predicted today by IEEE1584-2018.

In recent editions of the NEC®, Sections were added to require the protection of an employee that is exposed to dangerous levels of incident energy while working on energized equipment. To avoid serious injuries, employees, working on or near energized equipment, can only withstand a small fraction of the incident energy to which equipment may be subjected by the allowances of 230.95(A). This substantiation compares the levels of equipment damage allowed by existing 230.95(A) with the levels allowed by the employee arc-flash protection requirements of 240.67 and 240.87. It shows that the equipment damage allowed by the employee arc-flash protection requirements of 240.67 and 240.87 is just a small fraction of that allowed by 230.95(A).

EXAMPLES:

The following example utilizes IEEE 1584-2018 for a 480 volt arcing fault with 32mm equipment spacing, in a 20"x20"x20" box and an HCB configuration (horizontal conductors in a metal enclosure). Equipment damage is described in terms of kW-cycles which is a product of arcing current (kA) X number of arcing cycles (cycles) X arc voltage (100 volts on a 480 system).

Worst Case Equipment Damage with 10 kA Available Fault Current As Allowed by 230.95(A)

The IEEE 1584-2018 minimum arcing current is 6.09kA. Using the maximum 230.95(A) opening time of 60 cycles, the equipment damage is (6.09 kA X 60 cycles X 100 arcing volts) = 36,540 kW-cycles. See Figure 1.

Worst Case Equipment Damage with 10 kA Available Fault Current As Allowed by List Item 1.

The IEEE 1584-2018 minimum arcing current is 6.09kA. Assuming the maximum opening time of 4.2 cycles (0.07 seconds) for 240.67(B), the equipment damage is 6.09 kA X 4.2 cycles X 100 arcing volts) = 2,558 kW-cycles. Assuming an opening time of 7 cycles for 240.67(B)(1) and (B)(3), the equipment damage is (6.09 kA X 7 cycles X 100 arcing volts) = 4,263 kW-cycles. Assuming an opening time of 1/2 cycle for 240.67(B)(4), the equipment damage is (6.09 kA X 0.5 cycles X 100 arcing volts) = 305 kW-cycles. Worst-case damage for the minimum arcing current with this exception for fusible switches (4,263 kW-cycles) is less than 12% of the worst-case damage allowed by 230.95(A) (36,540 kW-cycles). See Figure 1.

Worst Case Equipment Damage with 10 kA Available Fault Current As Allowed by List Item 2.

The IEEE 1584-2018 minimum arcing current is 6.09kA. Assuming an opening time of 4 cycles for 240.87(B)(1), (B)(2), or (B)(4), the equipment damage is (6.09 kA X 4.0 cycles X 100 arcing volts) = 2,436 kW-cycles. Assuming an opening time of 3 cycles for 240.87(B)(5) or (B)(6), the equipment damage is (6.09 kA X 3 cycles X 100 arcing volts) = 1,827 kW-cycles. Worst-case damage for the minimum arcing current with this exception for circuit breakers (2,426 KW-Cycles) is less than 7% of the worst-case damage allowed by 230.95(A) (36,540 kW-cycles). See Figure 1.

(Insert attached Figure 1 here)

Figure 1 shows that equipment damage allowed by this Public Comment is always, from 10,000 amperes available through 100,000 amperes available, just a small fraction of the equipment damage allowed by 230.95(A).

One might ask whether it is possible that the alternate protective systems in this Public Comment could be set such that they might provide arc energy reduction, but not operate during a lower level arcing ground fault where traditional GFPE will provide protection. That question is answered by the very last lines of the new language for both fusible switches and circuit breakers, as both the fusible switches and circuit breakers must be "set to operate at the lower of the calculated minimum arcing current or

38% of the available fault current.” Since we know the minimum three phase arcing current from IEEE 1584-2018 and the minimum sustainable phase to ground arcing current of 38% of the available fault current, we know whether or not the fusible switch or circuit breaker is set to operate at those values. SO, THERE IS NO MINIMUM VALUE OF ACTUAL ARCING CURRENT THAT COULD BE SO SMALL AS TO BE PICKED UP BY 230.95(A) REQUIREMENTS THAT WOULD NOT ALSO BE SENSED BY THE REQUIREMENTS OF LIST ITEMS 1 AND 2.

Let’s look at an example with 10,000 available short-circuit amperes (lowest available fault current for which List Items 1 and 2 could apply). In this case the minimum 1584-2018 three-phase arcing current is 6.09 kA and the minimum sustainable phase-to-ground arcing current is 38% of 10,000 amps = 3.8 kA. Per the requirements of the list items the fusible switch or circuit breaker must be set to operate at the lower of either 6.09 kA or 3.8 kA, so the fusible switch or circuit breaker must operate for arcing currents of 3.8 kA or greater. If a three phase arcing fault occurs it is calculated to be 6.09 kA with the possibility that a single phase to ground arcing fault could be as low as 3.8 kA. In either case, the requirements of List Items 1 and 2 assure that the arcing fault is taken off-line in no more than 7 cycles for List Item 1 and no more than 4 cycles for List Item 2, while 230.95(A) would allow a full 60 cycles. What happens if the available fault current is less than or even significantly less than 10,000 amperes? Then the List Items 1 and 2 do not apply and GFPE would be required.

Energy reducing maintenance switches (240.67(B)(2) and 240.87(B)(3)) are not included in the exceptions because energy-reducing maintenance switches are typically turned off when a worker is not working on energized equipment, whereas ground fault protection is constantly protecting the equipment, whether or not a worker is working on the energized equipment.

The Approved Equivalent Means, (240.67(B)(5) and 240.87(B)(7)), are excluded because the opening times for these methods are unclear.

KEY BENEFIT:

While GFPE can often be set as low as 200 amperes, because of numerous nuisance GFPE openings, in some cases even for ground faults in 277-volt lighting circuits, it has become common for plant electricians, plant engineers, consulting engineers, and electrical contractors to set GFPE at the maximum allowable 230.95 and 517.17 (C) settings. That has solved a portion of the nuisance tripping problem, but even set at the maximum, it is often difficult to selectively coordinate feeder GFPE with sub-feeder phase overcurrent protective devices of 400 amperes or greater. So, for example, even with a service GFPE set at the 230.95 maximum and a feeder GFPE set at the 517.17(C) maximum, a ground fault on a 400 ampere (or larger) sub-feeder circuit can easily also open the GFPE on the feeder, blacking out the entire feeder. With List Items 1 and 2, the GFPE is no longer required on a service and therefor on the 517.17(C)-required feeder, or on a 215.10 feeder and therefor on the 517.17(C)-required sub-feeder. The equipment is still protected (even better protected) and an entire feeder is not subjected to a nuisance opening because of a ground fault on a sub-feeder. The key benefit of this Public Comment is that when these alternate methods are utilized, it provides the consulting engineer or design-build contractor with the ability to provide even better arcing fault protection for the equipment and the ability to prevent nuisance openings of feeders and sub-feeders.

CONCLUSION:

This Public Comment takes advantage of the arc-energy reduction technologies found in 240.67 and 240.87. It provides an exception for GFPE requirements in 215.10 and 230.95 whenever specific 240.67 and 240.87 methods to reduce clearing time are utilized. Arc energy reduction technologies, as detailed in List Items 1 and 2, must open in a much faster time than allowed by 230.95(A). Reviewing Figure 1, it becomes obvious that List Items 1 and 2 will limit the equipment’s arcing fault damage to a level that is considerably less than that currently allowed by the requirements found in 230.95(A).

Ground fault protection is not needed for faults that are not high impedance arcing faults. If the fault is not arcing, it is a bolted fault, which is safely interrupted by the phase overcurrent device (fuse or circuit breaker). If it is arcing, the limitations in List Items 1 & 2 assure that the arc energy reduction technologies allow less damage than allowed by existing 230.95. Opening “at the lower of the calculated minimum arcing current or 38% of the available fault current” assures that the arc energy reduction technologies open when a potentially damaging arc is initiated. There’s no need for the arc energy reduction technologies to operate unless a fault begins arcing.

It should be remembered that this Public Comment does not prohibit Ground-Fault Protection. It simply provides an alternative method of protecting equipment from burndown. If ground fault protection is desired for burndown protection of downstream equipment it can be included with the phase overcurrent device that is protecting that equipment. A key point to remember is that if the downstream equipment is protected with a phase overcurrent protective device (fuse or circuit breaker) at less than 1000 amperes, extensive testing, and field experience, over decades, has shown that the downstream equipment is adequately protected from arcing ground faults by that fuse or circuit breaker.

It should be noted that this Public Comment does not remove the requirements of 517.17(B). If 230.95 GFPE is installed in the service, a second level of GFPE must be installed in the feeders, and if 215.10 GFPE is installed on a feeder, a second level of GFPE must be installed on the sub-feeders.

It should also be noted that this Public Comment covers only the installation requirements of GFPE, not the performance requirements of GFPE, so this falls under the purview of CMP 15, not NFPA 99.

In closing, arc energy reduction technology, in order to protect human flesh (as opposed to copper, aluminum, and steel), must operate much quicker than is allowed in existing 230.95. Doesn't it just make common sense that arc energy reduction technologies which protect an employee's skin from third degree burns will also prevent copper, aluminum, and steel from melting?

Related Item

• FR 7565 • PI 1645 • PC 1616 • PI 1655 • PC 1617 • PI 1641 • PC 1615 • PC 1722 • PC 1766

Submitter Information Verification

Submitter Full Name: Vincent Saporita
Organization: Saporita Consulting
Street Address:
City:
State:
Zip:
Submittal Date: Tue Aug 27 09:02:32 EDT 2024
Committee: NEC-P15

Figure 1

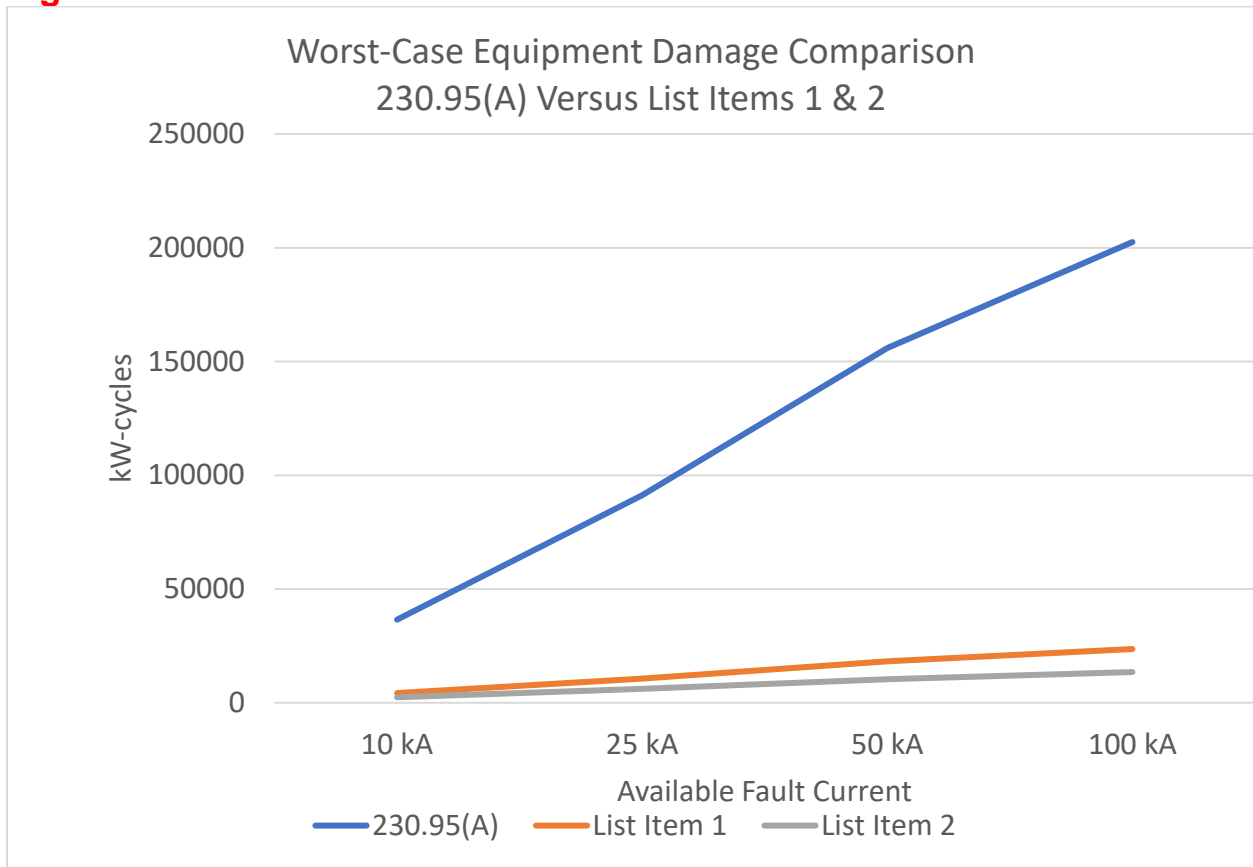

Figure 1 shows that equipment damage allowed by this Public Comment is always, from 10,000 amperes available through 100,000 amperes available, just a small fraction of the equipment damage allowed by 230.95(A).



Public Comment No. 1067-NFPA 70-2024 [Section No. 517.17(B)]

(B) Feeders.

Where ground-fault protection of equipment is provided for operation of the service disconnecting means or feeder disconnecting means as specified by 230.95 or 215.10, an additional step of ground-fault protection shall be provided in all next level feeder disconnecting means downstream toward the load. Such protection shall consist of overcurrent protective devices or other protective equipment that causes the feeder disconnecting means to open.

Ground-fault protection of equipment with automatic disconnecting means shall not be ~~required on alternate power supply sources, between alternate power supply~~ required between on-site power sources or set of power sources and any essential electrical system transfer switch, or on the load side of any essential electrical system transfer switch. [99:6.7.2.1.2.1]

Ground-fault indication without automatic disconnection shall be provided at any on-site power source. [99:6.7.2.1.2.2]

Statement of Problem and Substantiation for Public Comment

This comment is submitted by the Microgrid Task Group focused on correlating requirements between NFPA 99 Chapter 6 and NFPA 70 Article 517. The undefined term “alternate power supply” is replaced with the term “on-site power sources or set of on site power sources”.

Related Item

- PI 3659

Submitter Information Verification

Submitter Full Name: Chris Finen

Organization: Eaton Corporation

Street Address:

City:

State:

Zip:

Submittal Date: Tue Aug 13 12:58:02 EDT 2024

Committee: NEC-P15



Public Comment No. 661-NFPA 70-2024 [Section No. 517.20(A)]

(A) Receptacles and Fixed Equipment.

Wet procedure locations shall be provided with special protection against electric shock.
[99:6.3.2.3.1]

Special protection shall be provided by one of the following:

- (1) Isolated power systems that remain in operation in the event of a single line-to-ground fault condition that inherently limits the possible ground-fault current due to a first fault to a low value, without interrupting the power supply

Informational Note No. 1: Isolated power systems can eliminate the danger of electric shock to patients who might be more susceptible to leakage current and unable to move in their beds.

- (2) Power distribution system in which the power supply is interrupted if the ground-fault current does, in fact, exceed the trip value of a Class A GFCI [99:6.3.2.3.2(2)]
- (3) Where GFCI protection is used in an operating room, one of the following shall apply:

- a. Each receptacle shall be an individual GFCI device.
- b. Each receptacle shall be individually protected by a single GFCI device.

[99:6.3.2.3.9]

Informational Note No. 2 to (2) and (3): See ANSI/UL 943-2018, *Ground-Fault Circuit-Interrupters*, Annex E, and 110.3(B) for the manufacturers' installation instructions of listed GFCIs for information on the supply connection of life-support equipment to circuits providing GFCI protection of personnel at outlets.

- (4) See Annex E of ANSI/UL 943-2018, *Ground-Fault Circuit-Interrupters*, and 110.3(B) for the manufacturers' installation instructions of listed ground-fault circuit interrupters for information on the supply connection of life-support equipment to circuits providing ground-fault circuit-interrupter (GFCI) protection of personnel at outlets.

Exception: Branch circuits supplying only listed, fixed, therapeutic, and diagnostic equipment shall be permitted to be supplied from a grounded service, single- or 3-phase system if the following conditions are met:

- (1) *Wiring for grounded and isolated circuits does not occupy the same raceway.*
- (2) *All conductive surfaces of the equipment are connected to an insulated copper equipment grounding conductor.*

Additional Proposed Changes

<u>File Name</u>	<u>Description</u>	<u>Approved</u>
CN_364.pdf		

Statement of Problem and Substantiation for Public Comment

NOTE: The following CC Note No. 364 appeared in the First Draft Report on First Revision No. 8976.

CMP 15 should confirm what's shown in 517.20(A)(4) in respect to NEC® Style Manual 2.1.10.3.1. List item 4 appears to repeat much of Informational Note No. 2 to

(2) and (3), and refers the user to Annex E of ANSI/UL 943-2018 and 110.3(B) in normative text.

Related Item

- First Revision No. 8976

Submitter Information Verification

Submitter Full Name: CC Notes

Organization: NEC Correlating Committee

Street Address:

City:

State:

Zip:

Submittal Date: Fri Aug 02 09:41:46 EDT 2024

Committee: NEC-P15



Correlating Committee Note No. 364-NFPA 70-2024 [Section No. 517.20(A)]

Submitter Information Verification

Committee: NEC-AAC

Submittal Date: Fri May 10 09:52:31 EDT 2024

Committee Statement

Committee Statement: CMP 15 should confirm what's shown in 517.20(A)(4) in respect to NEC® Style Manual 2.1.10.3.1. List item 4 appears to repeat much of Informational Note No. 2 to (2) and (3), and refers the user to Annex E of ANSI/UL 943-2018 and 110.3(B) in normative text.

[FR-8976-NFPA 70-2024](#)

Ballot Results

✓ **This item has passed ballot**

12 Eligible Voters

1 Not Returned

11 Affirmative All

0 Affirmative with Comments

0 Negative with Comments

0 Abstention

Not Returned

McDaniel, Roger D.

Affirmative All

Ayer, Lawrence S.

Bowmer, Trevor N.

Hickman, Palmer L.

Holub, Richard A.

Jackson, Peter D.

Kendall, David H.

Manche, Alan

Osborne, Robert D.

Porter, Christine T.

Schultheis, Timothy James

Williams, David A.



Public Comment No. 1794-NFPA 70-2024 [New Section after 517.25]

TITLE OF NEW CONTENT

517.28 Signs

(A) On-site Sources

A sign shall be placed at the service-entrance equipment, indicating type and location of each on-site power source.

Exception: A sign shall not be required for Battery-Equipped Emergency Luminaires.

(B) Grounding.

Where removal of a grounding or bonding connection in a power source equipment interrupts the grounding electrode conductor connection to another power source(s) grounded conductor, a warning sign shall be installed stating:

WARNING

SHOCK HAZARD EXISTS IF GROUNDING

ELECTRODE CONDUCTOR OR BONDING JUMPER

CONNECTION IN THIS EQUIPMENT IS REMOVED

WHILE ANOTHER SOURCE(S) IS ENERGIZED.

The warning sign(s) or label(s) shall comply with 110.21(B).

Statement of Problem and Substantiation for Public Comment

This is a resubmittal of first draft PI-3754 - the statement at that time was -The requirement for signage is currently required by Art. 700 but currently not included in 517. This PI brings this requirement into 517 for any EES source. The language was updated to reflect the elimination of the terms "normal source" and "alternate source" in favor of "on-site", etc. to support microgrid application of different source types. - This PI was rejected with a committee statement of "No justification provided to require signage". With this resubmittal of this PI I provide the following for justification and reconsideration:

1) The proposed signage to identify all power sources at the site is important for the Emergency Response Teams that might be called into action if the facility has a fire related issue. By providing signage we will be facilitating the ER teams' safety and effectiveness during emergencies at healthcare facilities. There is plenty of mention of the importance of the EMR's to be able to disconnect all power sources when they arrive on site as can be evidenced by the following article.

Securing Utilities at Commercial Fires

FirefighterNation Staff

10.1.2010

Share

At a commercial structure fire, it's important that the truck companies assigned to securing utilities are familiar with utility hardware and the hazards associated with each system.

Occupancy type will usually drive the type, size, complexity and placement of utilities. Considering that

the time and personnel needed to secure utilities are often underestimated, preplanning is the best way for truck companies to become familiar with the different systems in their first-due area, how to secure them and how long it will take.

Upon arrival at an incident scene, truck companies should put in an early request to the utility company to respond to the incident to help ensure that the utilities are secured. On occasion, complex systems may need to be secured by the responsible party of the occupancy or the power company.

As firefighters, we should know not only what we can shut off, but also what objects we must avoid. With that in mind, this article will address some of the most common electrical hardware that crews may encounter when at the scene of a commercial fire.

Commercial & Industrial Power Shut-Offs

Commercial buildings and strip malls have service entry cabinets, which are usually found in the back of the structure and may be marked with the utility company's name. These cabinets contain a variety of shut-off configurations and may be marked with individual zones or suite numbers. The main power disconnects are in the same panel or adjacent to the meter. In strip malls, the anchor store may have its own main panel and several sub-panels.

There are three general types of disconnects: 1) fused or non-fused pull-out, 2) circuit breaker and 3) external lever. The external lever is the most common type in commercial buildings. It's used to control single electric devices and will make a loud "pop" sound when turned off. (See photos, p. 39.)

Electrical Rooms

Many buildings, especially the anchor occupancy in a strip mall, will have an electrical room with a utility company lock box. Most often, the Knox-Box keys on the truck won't work on these exterior doors, as the box belongs to the utility company; however, there will be an interior door that's accessible with a Knox-Box key. Although this door is safe to force open, it's more effective and provides better customer service to pick another door in the rear and open it with a key to access the interior door to the electrical room.

The inside of this electrical room will contain main shut-offs as well as sub-panels. Here, it's possible to shut off certain sections of the occupancy, while leaving certain zones on (i.e., coolers for food).

In smaller, isolated fires where securing the entire power to a strip mall may not be necessary, each individual occupancy may contain its own sub-panel that controls utilities for that specific business. These sub-panels will look like a residential panel, and each breaker should be labeled for the device(s) it controls.

Generators

Generators are often overlooked when securing utilities. Most commercial generators operate in the same fashion. Industrial generators store some type of fuel (most often natural gas or diesel), for the generator head that provides electrical current. These generators are usually hardwired permanently into the building's electrical system.

When securing power, it's important to know that once the power is secured, a back-up generator may also need to be secured. There are two ways to prevent a generator from delivering power to the structure: 1) shut off the generator or 2) shut off the breaker that feeds the building from the generator.

A generator usually has numerous doors in the housing with most often only one leading to the panel that enables the system to be secured. The door that usually contains the shut-off switches will be on the end of the cabinet, opposite of the exhaust. The exhaust is on the end of the cabinet that has no baffles (due to being soundproofed to help reduce the noise of the exhaust).

When securing the breaker, there are two types of generator transfer switches: automatic and manual. These systems are often driven by building code requirements and should be identified prior to a fire.

An automatic system turns on automatically and feeds power to the building from the generator when the main power has an outage or has been turned off. This back-up power must be secured to ensure that back-up power is not re-energizing the system. In a manual system, truck companies must ensure that the generator is not turned on, but no shut-off procedures need to occur.

Electrical Boxes

Equally important as knowing what to shut off during a fire is identifying what will hurt us and what we should avoid. Electrical boxes are found everywhere and have no standard shape or size. Utility electrical boxes in particular are extremely dangerous and should not be opened, as there is no shut off within them.

Switching Cabinets: These boxes contain primary cables in and out, and are used to switch power on and off, much like a light switch. These boxes are usually the bigger electrical boxes on the property and may be controlled from a remote location by the utility company. If it's safe to do so, obtain the number on the box to relay to the utility company. Important: Firefighters should avoid these boxes, as they have extremely high voltage and there is nothing for us to secure!

Transformers: Transformers step down electricity from primary to secondary voltage and feed into a service entrance cabinet or breaker panel. These boxes contain a high-grade mineral oil used to keep wires cool and are smaller than switching cabinets. These boxes come in different shapes and sizes and make a "buzzing" sound. They also have numbers on them that may be relayed to the utility company. Again, firefighters should avoid these boxes, as they are also very high voltage and there is nothing for us to secure.

Communication Cabinets: These cabinets come in a variety of shapes and sizes and are usually low voltage. If a meter is attached to these systems, we should assume it's high voltage. There is nothing for firefighters to secure in the boxes, and they should not be opened up.

Final Word

Securing utilities on commercial structures is not as simple as flipping one switch; it's an involved task that requires preplanning and time. Technology is changing daily, and it's therefore important that firefighters stay knowledgeable about new systems. Become familiar with building code requirements for your respective cities, as this will often drive how shut-offs are arranged.

2) Regarding the signage for grounding here is an excerpt from the NEC Handbook which provides justification.

"Emergency and standby systems that have a solid (unswitched) neutral in the transfer equipment (nonseparately derived system) rely on the grounding and bonding connections in the normal source supply equipment to ensure that the ground-fault current path is completed from a ground fault to the alternate source. If a main or system bonding jumper is removed [e.g., to perform testing on ground-fault protection of equipment (GFPE) systems], service personnel could inadvertently become part of the current path if a ground fault occurs."

Related Item

- PI-3754

Submitter Information Verification

Submitter Full Name: Jamie Schnick
Organization: HCAI/OSHPD
Affiliation: CA Department of Health Care Access and Information/Office of Hospital Planning and Development
Street Address:
City:
State:
Zip:
Submittal Date: Tue Aug 27 11:52:30 EDT 2024
Committee: NEC-P15



Public Comment No. 1283-NFPA 70-2024 [Section No. 517.25]

517.25 Essential Electrical Systems for Health Care Facilities.

Type 1 and Type 2 essential electrical systems (EES) for health care facilities shall comprise separate branches capable of supplying a limited amount of lighting and power service, which is considered essential for life safety and ~~orderly cessation of procedures~~ effective facility operation during the ~~time normal electrical~~ time electrical service is interrupted for any reason.

Informational Note: See NFPA 99-2024, *Health Care Facilities Code*, for information on essential electrical systems.

Statement of Problem and Substantiation for Public Comment

This public input is submitted on behalf of the Microgrid Task Group formed under the direction of the ELS Committee of NFPA 99 to provide correlation input to CMP-15 related to the use of microgrids and distributed energy resources in health care.

The current language does not include the "protect in place" function of healthcare facilities during power outages. The revision is language "borrowed" from 517.29 Informational note, more accurately describes the function of essential electrical systems at healthcare facilities. The text was also revised to remove the term normal electrical service as this is an undefined term.

Related Item

- PI-4274 & PI-2787

Submitter Information Verification

Submitter Full Name: Jamie Schnick
Organization: HCAI/OSHPD
Affiliation: CA Department of Health Care Access and Information/Office of Hospital Planning and Development
Street Address:
City:
State:
Zip:
Submittal Date: Mon Aug 19 16:44:11 EDT 2024
Committee: NEC-P15



Public Comment No. 34-NFPA 70-2024 [Section No. 517.29]

517.29 Type 1 Essential Electrical Systems (EESs).

~~Type 1 essential electrical systems~~

(

EESs) shall comply with

A) Applicability.

(1) The requirements of 517.29

~~(A) and 517.29(B) :~~

through 517.35 shall apply to Type 1 EESs.

(2) Type 1 EESs shall be required for Category 1 spaces.

(3) Type 1 EESs shall be permitted to serve Category 2, Category 3, and Category 4 spaces.

(4) Category 1 spaces shall not be served by a Type 2 EES. [99: 6.4.2]

Informational Note:

~~Type 1 essential electrical systems (EESs)~~

Type 1 EESs are comprised of three separate branches capable of supplying a limited amount of lighting and power service that is considered essential for life safety and effective facility operation during the time the normal electrical service is interrupted for any reason. These three separate branches are the life safety, critical, and equipment branches. [99: A.6.7.5.1]

~~(A) Applicability:~~

~~The requirements of 517.29 through 517.35 shall apply to Type 1 EESs. Type 1 systems shall be required for Category 1 spaces. Type 1 systems shall be permitted to serve Category 2, Category 3, and Category 4 spaces~~

Informational Note No. 2: See NFPA 99- 2024 , *Health Care Facilities Code* , 6.7.5 and 6.7.6, for additional information on Type 1 and Type 2 EESs .

Informational Note No.

~~4~~

~~3:~~

~~See~~

See NFPA 99- 2024 , *Health Care Facilities Code* , for performance, maintenance, and testing requirements of EESs in hospitals. See NFPA 20- 2022 , *Standard for the Installation of Stationary Pumps for Fire Protection* , for installation of centrifugal fire pumps.

~~Informational Note No. 2: See NFPA 99-2024, *Health Care Facilities Code* , 6.7.5 and 6.7.6, for additional information on Type 1 and Type 2 EESs.~~

~~(B) Type 1 Essential Electrical Systems:~~

~~Category 1 spaces shall be served by a Type 1 EES. [99: 6.4.1]~~

~~Category 1 spaces shall not be served by a Type 2 EES. [99: 6.4.2]~~

<u>File Name</u>	<u>Description</u>	<u>Approved</u>
PC_34_517.29_reorganization.docx	517.29 reorganization	

Statement of Problem and Substantiation for Public Comment

This PC proposes to: (1) create a list for the requirements for clarity (2) remove redundant language that Cat 1 spaces be served by a Type 1 EES (3) relocate the informational notes after the requirements for clarity (4) Use the acronym EES throughout as permitted by the NEC Style Manual
See attached word doc

Related Item

- FR 8988

Submitter Information Verification

Submitter Full Name: Vincent Della Croce
Organization: Siemens
Street Address:
City:
State:
Zip:
Submittal Date: Thu Jul 11 07:51:01 EDT 2024
Committee: NEC-P15



Correlating Committee Note No. 34-NFPA 70-2024 [Section No. 240.2]

Submitter Information Verification

Committee: NEC-AAC

Submittal Date: Tue May 07 14:49:25 EDT 2024

Committee Statement

Committee Statement: The Correlating Committee directs that CMP 10 review FR 9197 and consider revising the text to align with recommended wording regarding reconditioning. The recommended wording for (A) would be “The installation of the following reconditioned equipment shall be permitted:”, and the recommended wording for (B) would be “The installation of the following reconditioned equipment shall not be permitted.”.

First Revision No. 9197-NFPA 70-2024 [Section No. 240.2]

Ballot Results

✔ **This item has passed ballot**

12 Eligible Voters

1 Not Returned

11 Affirmative All

0 Affirmative with Comments

0 Negative with Comments

0 Abstention

Not Returned

McDaniel, Roger D.

Affirmative All

Ayer, Lawrence S.

Bowmer, Trevor N.

Hickman, Palmer L.

Holub, Richard A.

Jackson, Peter D.

Kendall, David H.

Manche, Alan

Osborne, Robert D.

Porter, Christine T.

Schultheis, Timothy James

Williams, David A.



Public Comment No. 1284-NFPA 70-2024 [Section No. 517.30]

517.30 Sources of Power.

(A) Independent Power Sources.

EES loads shall be served by two or more independent sources (or sets of sources). One source (or sets of sources) shall be on-site power production equipment, storage components, or a combination sized to supply the entire EES.

Informational Note: An example of a set of sources may be several generators that when combined serve the entire EES.

(B) On-Site Power Sources for the EES.

Power sources for the EES shall be one or more of the following as specified in 517.30(B)(1) through 517.30(B)(5).

(1) Generating Units.

Generating units shall be permitted to serve as the on-site power source for all or part of an EES.

(2) Fuel Cell Systems.

Fuel cell systems shall be permitted to serve as the on-site power source for all or part of an EES.

(a) $N + 1$ units shall be provided where N units have sufficient capacity to supply the demand load of the portion of the system served.

(b) Where life safety and critical portions of the distribution system are present, a connection shall be provided for a portable diesel generator.

Informational Note: See NFPA 853-2020, *Standard for the Installation of Stationary Fuel Cell Power Systems*, for information on installation of stationary fuel cells.

(3) Energy Storage Systems.

Energy storage systems shall be permitted to serve as the alternate source for all or part of an EES.

Informational Note: See NFPA 111-2022, *Standard on Stored Electrical Energy Emergency and Standby Power Systems*, for information on the installation of energy storage systems.

(4) Health Care Microgrid.

An EES shall be permitted to be supplied by a health care microgrid that also supplies nonessential loads. The health care microgrid shall be permitted to share distributed resources with the normal system. Health care microgrid systems shall be designed with sufficient reliability to provide effective facility operation consistent with the facility emergency operations plan. Health care microgrid system components shall not be compromised by failure of the normal source.

Informational Note: See NFPA 99-2024, *Health Care Facilities Code*, for information on health care microgrids.

(C) Utility Supply Power.

Utility supply power shall not be used as a source for the EES unless permitted elsewhere in this article.

Informational Note: See 517.35 and 517.45 for essential system loads that can be supplied from dual sources of utility supply power.

(D) Location of EES Components.

Electrical system components shall be located to minimize interruptions caused by natural forces common to the area or natural disasters identified in the facility's emergency operations plan. [99:6.2.4.1]

(1) Sources.

Installation of two independent sources (or sets of sources) shall be located to reduce the likelihood of simultaneous interruption of EES components and non-EES components.

(2) Feeders.

Feeders and associated raceways serving essential electrical system transfer equipment shall be located such that physical separation is provided between each of the electrical system's feeders to prevent possible simultaneous interruption. [99:6.2.4.3]

(E) If the on-site power source or set of power sources serving the essential electrical system does not have the capacity to support the anticipated demand load when any single on-site power source is disabled for service, the electrical distributions system shall include a permanent switching means to connect a portable or temporary on-site power source that is available for the duration of the servicing and that complies with the following requirements:

- (1) The connection shall be provided to support the connection of equipment sized to match or exceed the single largest on-site power source.
- (2) The connection to the portable or temporary on-site power source shall not require modification of the permanent system wiring.
- (3) Transfer of power to the portable or temporary on-site power source shall be in accordance with 517.32.
- (4) The connection point for the portable or temporary on-site power source shall be marked with the phase rotation and system bonding requirements.
- (5) Mechanical or electrical interlocking shall prevent inadvertent interconnection of power sources.
- (6) The switching means shall include a contact point that annunciates at a location remote from the generator or essential power production and/or storage units or at another facility monitoring system to indicate that the on-site power source is disconnected from the essential electrical system.

Statement of Problem and Substantiation for Public Comment

With the proposed revision to section 517.26 (FR-8982), Article 700 will not apply to healthcare facilities, this requirement (currently in 700.4(F) to make provisions for a temporary source of power for the essential system to allow for servicing or repair [700.3(F)] of on-site power generation equipment will be lost. This requirement is copied over from article 700 with revisions so it not only applies to generators, but also includes any microgrid sources at healthcare facilities to address the concern that if provisions are not provided during initial installation for temporary power connections, the facility will not be able to service power generation equipment without either disabling the system (ie no essential power source during repairs) or rewiring the building wiring system (i.e. disconnecting existing essential sources to connect temporary, which again would be an outage). Article 517.30 requires (2) independent sources for the essential system and these provisions for temporary power will ensure that this requirement can be met while the essential power sources are being maintained. Note while

the existing section 700.3 is entitled "Test and Maintenance" this requirement is actually an installation requirement, and with the text added to 517.30 clearly provides direction on the process associated with putting equipment in place and making it ready for use.

Related Item

- PR-8982

Submitter Information Verification

Submitter Full Name: Jamie Schnick
Organization: HCAI/OSHPD
Affiliation: CA Department of Health Care Access and Information/Office of Hospital Planning and Development
Street Address:
City:
State:
Zip:
Submittal Date: Mon Aug 19 17:18:25 EDT 2024
Committee: NEC-P15



Public Comment No. 1869-NFPA 70-2024 [Section No. 517.30(A)]

(A) Independent Power Sources.

~~EES- Essential Electrical System~~ loads shall be served by two or more independent sources (supplied by a minimum of two independent power sources or sets of sources). ~~One source (or sets of sources)- power sources and sets of feeders designed to ensure sufficient reliability to provide effective facility operation consistent with the facility's emergency operations plan. At least one power source shall be on-site power production equipment, storage components, or a combination and sized to supply the entire EES- essential electrical system. The additional power source(s) shall be permitted to be either on-site or off-site.~~

Informational Note: An example of a set of sources may be several generators that when combined serve the entire EES.

Statement of Problem and Substantiation for Public Comment

This comment is submitted by the NFPA 70-99 Micrograms Task Force. The language proposed changes nothing, but aligns language between this document and NFPA 99. This is not being proposed as an extract, as these changes are not yet finalized by NFPA 99.

Related Item

- 8991

Submitter Information Verification

Submitter Full Name: Walter Vernon

Organization: Mazzetti

Street Address:

City:

State:

Zip:

Submittal Date: Tue Aug 27 19:09:59 EDT 2024

Committee: NEC-P15



Public Comment No. 1878-NFPA 70-2024 [Section No. 517.30(B)(2)]

(2) Fuel Cell Systems.

Fuel cell systems shall be permitted to serve as the on-site power source for all or part of an EES.

- ~~N + 1 units shall be provided where N units have sufficient capacity to supply the demand load of the portion of the system served.~~
- ~~Where life safety and critical portions of the distribution system are present, a connection shall be provided for a portable diesel generator.~~

Informational Note: See NFPA 853-2020, *Standard for the Installation of Stationary Fuel Cell Power Systems*, for information on installation of stationary fuel cells.

Statement of Problem and Substantiation for Public Comment

This comment is being proposed by the NFPA 70-99 Microgrids Task Force. The proposed change here, coupled with a later proposal to add requirements for connections to temporary power sources, will align with proposed 99 language. The 99 language is more general for all sources, and is highly recommended.

Related Item

- 8864

Submitter Information Verification

Submitter Full Name: Walter Vernon
Organization: Mazzetti
Affiliation: NFPA 70-99 Microgrids Task Force
Street Address:
City:
State:
Zip:
Submittal Date: Tue Aug 27 19:34:45 EDT 2024
Committee: NEC-P15



Public Comment No. 2083-NFPA 70-2024 [Section No. 517.30(B)(2)]

(2) Fuel Cell Systems.

Fuel cell systems shall be permitted to serve as the on-site power source for all or part of an EES.

(a) N + 1 units shall be provided where N units have sufficient capacity to supply the demand load of the portion of the system served.

(b) Where life safety and critical portions of the distribution system are present, a connection shall be provided for a portable diesel generator.

Informational Note: See NFPA 853-2020, *Standard for the Installation of Stationary Fuel Cell Power Systems*, for information on installation of stationary fuel cells.

Additional Proposed Changes

<u>File Name</u>	<u>Description</u>	<u>Approved</u>
TIA_70_23_14.pdf	TIA 23-14 (Log No. 1752)	

Statement of Problem and Substantiation for Public Comment

NOTE: This public comment originates from Tentative Interim Amendment No. 23-14 (Log No. 1752) issued by the Standards Council on November 30, 2023 and per the NFPA Regs., needs to be reconsidered by the Code Making Panel for the next edition of the Document. This TIA was issued after the Public Input closing date and was emulated as a Public Comment.

Substantiation: In the 2017 revision cycle, CMP 4 deleted Part VIII of Article 692, then during the 2020 revision cycle Article 692 was reduced to six parts. There are no references in the current language to voltages, either 1000 volts or more, or 1000 volts or less, therefore the incorrect references need to be remedied through the TIA process.

Emergency Nature: The standard contains an error or an omission that was overlooked during the regular revision process.

In the 2017 and 2020 NEC code revision cycles Part VII and VIII were removed, with the 2020 revision cycle reducing a total of 6 parts, this TIA seeks to correct the error of identifying the parts that were removed during the previous revisions' cycles.

Related Item

- Issued TIA No. 23-14 (Log No. 1752)

Submitter Information Verification

Submitter Full Name: NFPA TIA

Organization: Code-Making Panel 15

Street Address:

City:

State:

Zip:

Submittal Date: Thu Aug 29 10:21:28 EDT 2024
Committee: NEC-P15



Tentative Interim Amendment

NFPA[®] 70[®]

National Electrical Code[®]

2023 Edition

Reference: 517.30(B)(3)(a)

TIA 23-14

(SC 23-11-9 / TIA Log #1752)

Pursuant to Section 5 of the NFPA *Regulations Governing the Development of NFPA Standards*, the National Fire Protection Association has issued the following Tentative Interim Amendment to NFPA 70[®], *National Electrical Code[®]*, 2023 edition. The TIA was processed by the NEC Code-Making Panel 15, and the Correlating Committee on National Electrical Code and was issued by the Standards Council on November 30, 2023, with an effective date of December 20, 2023.

1. Revise section 517.30(B)(3)(a) to read as follows:

517.30(B)(3) Fuel Cell Systems. Fuel cell systems shall be permitted to serve as the alternate power source for all or part of an EES. [99:6.7.1.5.1]

(a) Installation of fuel cells shall comply with the requirements in Parts I through ~~VI~~ **VII** of Article 692 ~~for 1000 volts or less and Part VIII for over 1000 volts.~~

Issue Date: November 30, 2023

Effective Date: December 20, 2023

(Note: For further information on NFPA Codes and Standards, please see www.nfpa.org/docinfo)

Copyright © 2023 All Rights Reserved
NATIONAL FIRE PROTECTION ASSOCIATION



Public Comment No. 1880-NFPA 70-2024 [New Section after 517.30(B)(4)]

(5) Temporary On-Site Power Source for Maintenance or Repair of the On-Site Power Source

If the on-site power source of set of power sources serving the essential electrical system does not have sufficient capacity to support the maximum likely demand load when any single on-site power source is disabled for maintenance or repair, it shall include a permanent switching means to connect a portable or temporary on-site power source that is available for the duration of the maintenance or repair.

Statement of Problem and Substantiation for Public Comment

This comment is submitted by the NFPA 70-99 Task Force on Microgrids. This comment moves the text that is currently applicable only to fuel cells and makes it general for any source. It is the language currently proposed by NFPA 99. It cannot be an extract because it has not yet been approved by 99. But, it will help the industry to have better alignment between the two documents.,

Related Item

- 8864

Submitter Information Verification

Submitter Full Name: Walter Vernon

Organization: Mazzetti

Affiliation: Microgrids Task Force of NFPA 99 and 70

Street Address:

City:

State:

Zip:

Submittal Date: Tue Aug 27 19:37:38 EDT 2024

Committee: NEC-P15



Public Comment No. 1290-NFPA 70-2024 [Section No. 517.31(A)]

(A) Separate Branches.

Type 1 EESs shall be comprised of three separate branches — life safety, critical, and equipment — capable of supplying a limited amount of lighting and power service that is considered essential for life safety and effective hospital operation.

The division between the branches shall occur at transfer switches where more than one transfer switch is required. [99:6.7.2.2.1]

Informational Note: Potential System Configuration

Additional Proposed Changes

<u>File Name</u>	<u>Description</u>	<u>Approved</u>
KMB_Diagram_V5_Submitted_to_NFPA.pdf	Diagram from NFPA 99	

Statement of Problem and Substantiation for Public Comment

The current diagrams show some potential configurations that may be possible. The proposed diagram shows a more expansive view of what is possible, and is, therefore, more accurate. Also, this is the diagram that will go into NFPA 99. Sharing the same diagram between the two documents will greatly enhance correlation.

Related Item

- FR 9016

Submitter Information Verification

Submitter Full Name: Walt Veernon

Organization: Mazzetti

Street Address:

City:

State:

Zip:

Submittal Date: Mon Aug 19 21:46:30 EDT 2024

Committee: NEC-P15

Annex B.6.1 On-Site, Off-Site, or Combination of On-Site and Off-Site Source Configuration

OFF-SITE, ON-SITE, OR COMBINATION OF ON-SITE AND OFF-SITE POWER SOURCES

ON-SITE, OFF-SITE, OR COMBINATION OF ON-SITE AND OFF-SITE POWER SOURCES

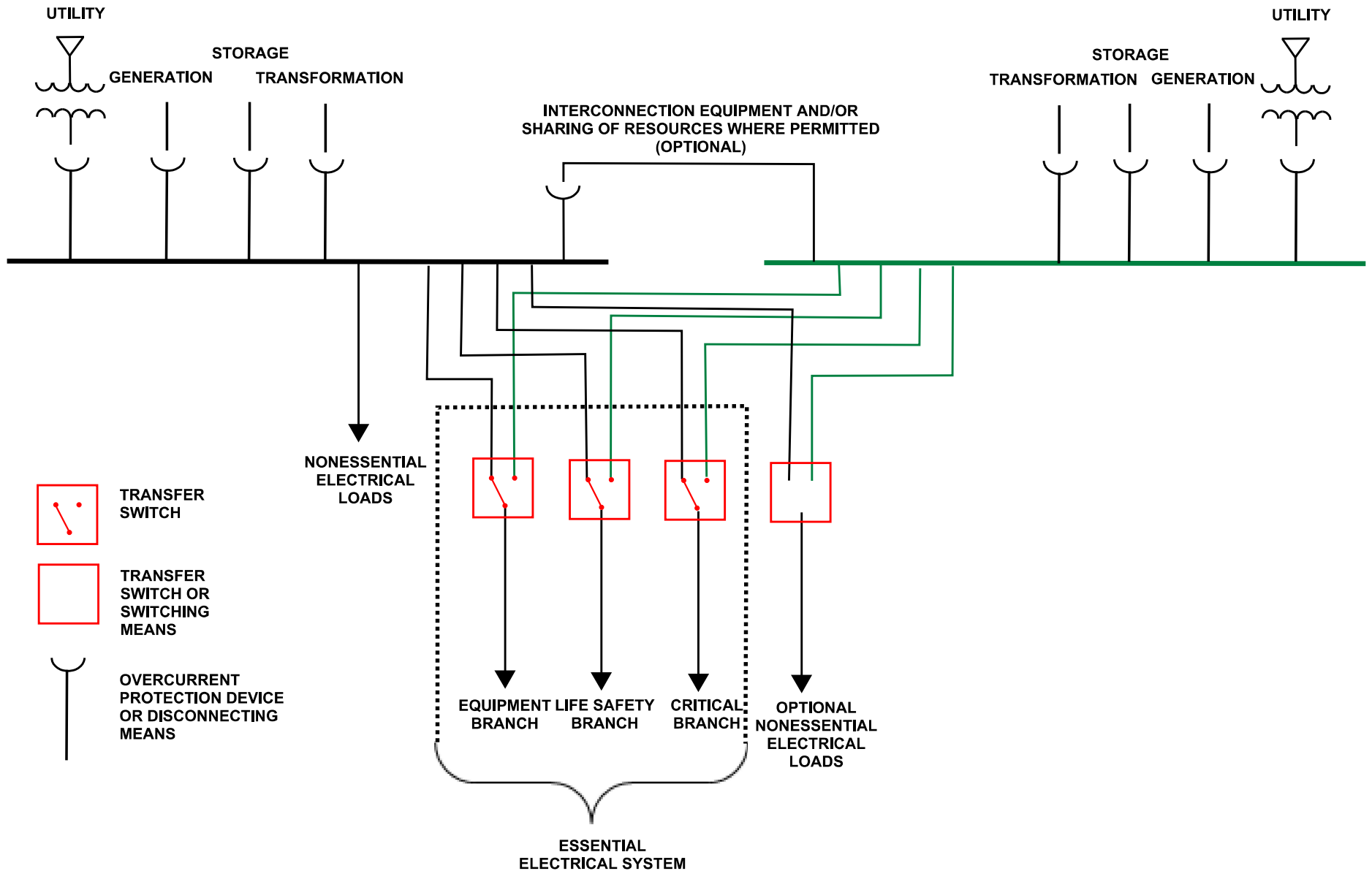



Public Comment No. 1285-NFPA 70-2024 [Section No. 517.31(B)]

(B) Transfer Switches.

~~Transfer switches shall comply with one of the following:~~

The number of transfer switches to be used shall be based on reliability, design and design:

load considerations. [99: 6.7.2.2.3]

Transfer switches shall comply with one of the following:

- (1) Each branch of the essential electrical system shall have one or more transfer switches.
- (2) One transfer switch shall be permitted to serve one or more branches in a facility with a continuous load on the switch of 150 kVA (120 kW) or less. [99:6.7.2.2.3.2]

Informational Note No. 1: See NFPA 99-2024, *Health Care Facilities Code*, 6.7.3.1, 6.7.2.2.5, 6.7.2.2.5.15, and 6.7.2.2.7, for more information on transfer switches.

Informational Note No. 2: See Figure Informational Note 517.31(B)(1).

Informational Note No. 3: See Figure Informational Note 517.31(B)(2).

Figure Informational Note 517.31(B)(1) Type 1 EES — Minimum Requirement (Greater Than 150 kVA) for Transfer Switch Arrangement.

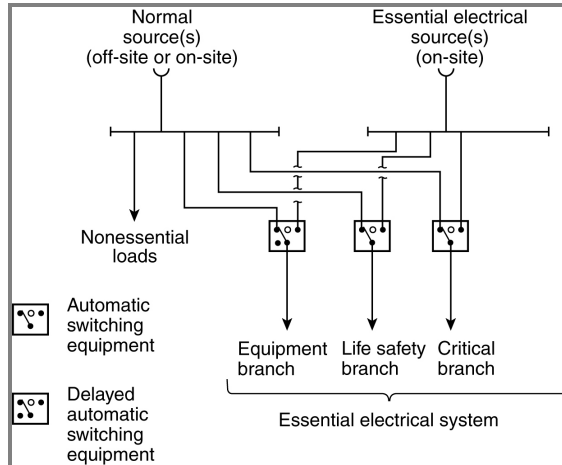
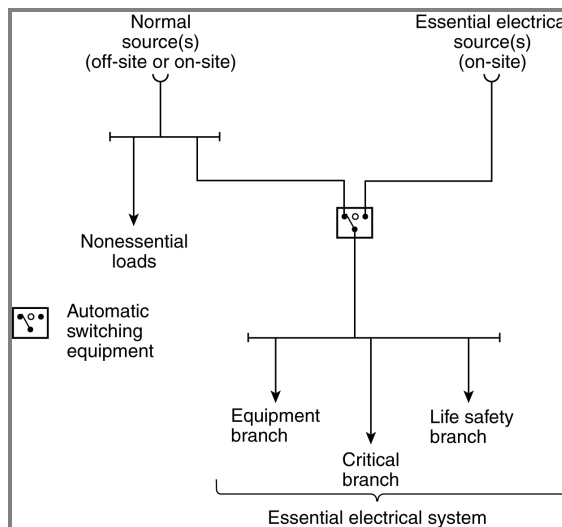

Figure Informational Note 517.31(B)(2) Type 1 EES — Minimum Requirement (150 kVA or Less) for Transfer Switch Arrangement.



(1) Optional Loads.

Loads served by an on-site source (or set of sources) not specifically named in this article shall be served by their own transfer switches such that the following conditions apply:

- (1) These loads shall not be transferred if the transfer will overload the on-site source(s).
- (2) These loads shall be automatically shed upon generating equipment overloading.

(2) Contiguous Facilities.

Hospital power sources and alternate power sources shall be permitted to serve the EESs of contiguous or same-site facilities.

Statement of Problem and Substantiation for Public Comment

Just a little clean-up proposed. NFPA 99 reference is added and order of text is rearranged. Note this matches the style and text in 517.42(B) which is the same statement for type 2 essential electrical systems.

Related Item

- FR-9016 & PI-2110

Submitter Information Verification

Submitter Full Name: Jamie Schnick
Organization: HCAI/OSHPD
Affiliation: CA Department of Health Care Access and Information/Office of Hospital Planning and Development
Street Address:
City:
State:
Zip:
Submittal Date: Mon Aug 19 17:31:18 EDT 2024
Committee: NEC-P15



Public Comment No. 1068-NFPA 70-2024 [Section No. 517.31(B) [Excluding any Sub-Sections]]

Transfer switches shall comply with one of the following:

- (1) The number of transfer switches to be used shall be based on reliability and design. Each branch of the essential electrical system shall have one or more transfer switches.
- (2) One transfer switch shall be permitted to serve one or more branches in a facility with a continuous load on the switch of essential electrical system load of 150 kVA (120 kW) or less. [99:6.7.2.2.3.2]

Informational Note No. 1: See NFPA 99-2024, *Health Care Facilities Code*, 6.7.3.1, 6.7.2.2.5, 6.7.2.2.5.15, and 6.7.2.2.7, for more information on transfer switches.

Informational Note No. 2: See Figure Informational Note 517.31(B)(1).

Informational Note No. 3: See Figure Informational Note 517.31(B)(2).

Figure Informational Note 517.31(B)(1) Type 1 EES — Minimum Requirement (Greater Than 150 kVA) for Transfer Switch Arrangement.

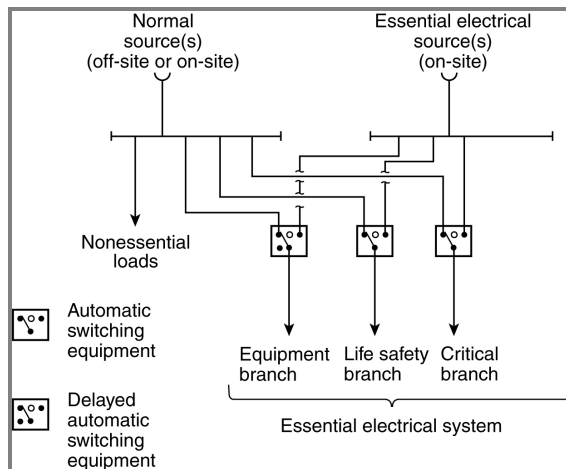
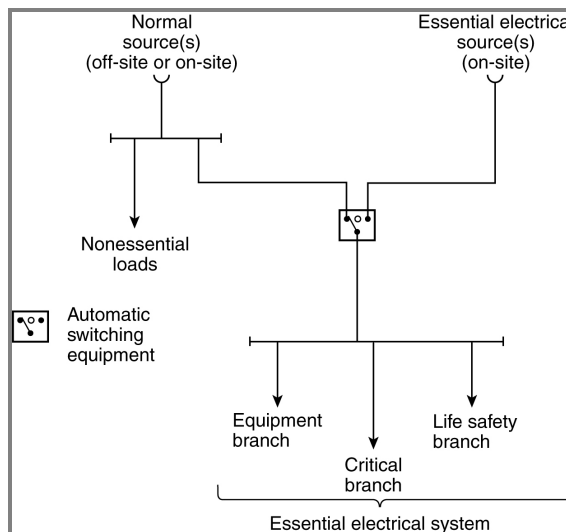

Figure Informational Note 517.31(B)(2) Type 1 EES — Minimum Requirement (150 kVA or Less) for Transfer Switch Arrangement.



Statement of Problem and Substantiation for Public Comment

The original PI attempts to correct some language that could be misinterpreted to mean it is permissible to use multiple transfer switches that mix the branches as long as the load in each transfer switch is kept below 150kVA. The intent is to allow smaller facilities with small essential electrical systems to not have to divide the EES into separate branches. However, since the requirement is written based on the load on the transfer switch and not the total EES load, it could be allowable to mix the branches on a very large EES as long as the load on each individual transfer switch was kept below 150kVA. This could compromise the safety and reliability of key systems directly related to life safety and patient care.

This has also been proposed in NFPA 99 for correction. The challenge is that the NFPA 99 cycle trails the NFPA 70 cycle by one year. Since this is extracted language, it will automatically be updated once NFPA 99 is published. However, that would mean this incorrect language may remain in NFPA 70 until 2029. This comment attempts to reopen this discussion for the committee to consider the best path to correct this issue for both Type 1 EES (517.31(B)) and Type 2 EES (517.42(B)).

Related Public Comments for This Document

<u>Related Comment</u>	<u>Relationship</u>
<u>Public Comment No. 1298-NFPA 70-2024 [Section No. 517.42(B)]</u>	Same issue for Type 2 EES
<u>Public Comment No. 1298-NFPA 70-2024 [Section No. 517.42(B)]</u>	

Related Item

- PI 2109

Submitter Information Verification

Submitter Full Name: Chris Finen
Organization: Eaton Corporation
Street Address:
City:
State:
Zip:
Submittal Date: Tue Aug 13 14:16:59 EDT 2024
Committee: NEC-P15



Public Comment No. 1286-NFPA 70-2024 [Section No. 517.31(C)(3)]

(3) Mechanical Protection of the Essential Electrical System.

The wiring of life safety and critical branches shall be mechanically protected by raceways. ~~Where installed as branch circuits in patient care spaces, the installation shall comply with the requirements of 517.13(A), 517.13(B), and 250.118.~~ Only the following wiring methods shall be permitted:

- (1) Nonflexible metal raceways, Type MI cable, RTRC marked with the suffix -XW, or Schedule 80 PVC conduit
- (2) Where encased in not less than 50 mm (2 in.) of concrete, Schedule 40 PVC conduit, flexible nonmetallic or jacketed metallic raceways, or jacketed metallic cable assemblies listed for installation in concrete
Exception to (1) and (2): Nonmetallic raceways shall not be used for branch circuits that supply patient care spaces.
- (3) Listed flexible metal raceways and listed metal sheathed cable assemblies, as follows:
 - (4) Where used in listed prefabricated medical headwalls
 - (5) In listed office furnishings
 - (6) Where fished into existing walls or ceilings, not otherwise accessible and not subject to physical damage
 - (7) Where necessary for flexible connection to equipment

For equipment

- a. To feed equipment that requires a flexible connection due to movement, vibration, or operation

Luminaires

- a. To feed luminaires installed in ceiling structures
- (8) Flexible power cords of appliances or other utilization equipment connected to the EES
- (9) Cables for Class 2 or Class 3 systems permitted in Article 517, Part VI, with or without raceways

Informational Note: See 517.13 for additional grounding requirements in patient care areas.

Statement of Problem and Substantiation for Public Comment

The sentence, "When installed as branch circuits in patient care spaces, the installation shall comply with the requirements of 517.13(A), 517.13(B) and 250.118." is not needed as these requirements are already called out in the sections referenced. By removing this extraneous sentence, we can avoid confusion as to whether "only the following wiring methods shall be permitted": applies only to branch circuits in patient care spaces or to all wiring of life safety and critical branches.

Added "To feed" in front of equipment that requires a flexible connection.. to reformat appropriate for list.

Added "To feed" in front of Luminaires... to reformat appropriate for list.

Related Item

• FR-9216 & PI-2144

Submitter Information Verification

Submitter Full Name: Jamie Schnick
Organization: HCAI/OSHPD
Affiliation: CA Department of Health Care Access and Information/Office of Hospital Planning and Development
Street Address:
City:
State:
Zip:
Submittal Date: Mon Aug 19 17:36:58 EDT 2024
Committee: NEC-P15



Public Comment No. 1153-NFPA 70-2024 [Section No. 517.32]

517.32 Branches Requiring Automatic Connection.

(A) Life Safety, Critical and ~~Critical Branch~~ Equipment Branches Used in a Type 1 EES.

(1) Division of Patient Care Functions Connected to ESS.

Those functions of ~~patient care depending on lighting or appliances that~~ that are considered essential for life safety and the effective operation of a of a health care facility with category 1 spaces that are connected to the EES shall be divided into the life safety branch, critical branch and the ~~critical branch, as~~ equipment branch as described in 517.33- ~~and~~ , 517.34 and 517.35 .

(2) Restoration of Power.

a) The life safety and critical branches shall be installed and connected to the on-site power source specified in 517.30(A) and 517.30(B) so that all functions specified herein for the life safety and critical branches are automatically restored to operation within 10 seconds after interruption of power. [99:6.7.5.3.1]

b) The equipment branch shall be installed and connected to the on-site power source specified in 517.30(A) and 517.30(B) such that equipment described in 517.35(A) are automatically restored to operation at appropriate time-lag intervals following the energizing of the life safety and critical branches. [99: 6.7.5.1.4.2(A)], after interruption of power.

Statement of Problem and Substantiation for Public Comment

The code requires that equipment described in 517.33, 517.34 and 517.35(A) & (B) be automatically restored to operation after interruption of power. The proposed a) and b) subsections below "Restoration of Power" allow for the current requirements regarding timing for power energization from on-site sources.

Note: I recommend that the committee consider removing the last sentence in 517.35 "such that equipment described in 517.35(A) are automatically restored to operation at appropriate time-lag intervals following the energizing of the life safety and critical branches. [99:6.7.5.1.4.2(A)]" as this appears to be a more appropriate location for this NFPA 99 extract.

Related Item

- FR-9026 & PI 2113

Submitter Information Verification

Submitter Full Name: Jamie Schnick
Organization: HCAI/OSHPD
Affiliation: CA Department of Health Care Access and Information/Office of Hospital Planning and Development
Street Address:
City:
State:
Zip:
Submittal Date: Fri Aug 16 08:51:54 EDT 2024
Committee: NEC-P15



Public Comment No. 1076-NFPA 70-2024 [New Section after 517.33]

517.33(D) For new high rise health care occupancies the following shall be connected to the life safety branch:

- (1) Jockey pumps
- (2) Air compressors serving dry-pipe and pre-action systems
- (3) Emergency command center equipment and lighting
- (4) Not less than one elevator serving all floors, with standby power transferable to any elevator
- (5) Mechanical equipment for smokeproof enclosures
- (6) Mechanical equipment required to conform with the requirements of NFPA 101 Section 9.3
- (7) Stairway video monitoring equipment as required by NFPA 101 11.8.8

[NFPA 101 11.8.5.3.4]

Statement of Problem and Substantiation for Public Comment

This text is extracted from NFPA 101 and should be included in NFPA 70 for applicability to high-rise health care facilities. (note text and this statement copied verbatim from proposed add to NFPA 99 at 1st draft meeting)

Related Item

- FR-9029

Submitter Information Verification

Submitter Full Name: Jamie Schnick
Organization: HCAI/OSHPD
Affiliation: CA Department of Health Care Access and Information/Office of Hospital Planning and Development
Street Address:
City:
State:
Zip:
Submittal Date: Tue Aug 13 19:14:24 EDT 2024
Committee: NEC-P15



Public Comment No. 1070-NFPA 70-2024 [Section No. 517.33]

517.33 Automatic Connection to _ Life Safety Branch.

~~(A)– Life Safety Branch.~~

The life safety branch shall be limited to circuits essential to life safety. [**99: 6.7.5.1.2.1**]

No functions other than those listed in 517.33(A).

(4)

through 517.33(

~~A)(7) shall~~

D) shall be connected to the life safety branch. .

(A) Life Safety Branch. The life safety branch shall supply power as follows:

- (1) Illumination of means of egress such as lighting required for corridors, passageways, stairways, and landings at exit doors, and all necessary ways of approach to exits

Informational Note: ~~See NFPA~~ See NFPA 101-2024, Life Safety Code, Sections 7.8 and 7.9.

- (2) Exit signs and exit directional signs

Informational Note: See NFPA 101-2024, *Life Safety Code*, Section 7.10.

- (3) Alarm and alerting systems, as follows:

- (4) Fire alarm systems

~~shall be required~~

a. .

- b. Alarm and alerting systems (other than fire alarm systems) shall be permitted to be connected to the life safety branch or critical branch. [99: 6.7.5.1.2.3]

c. Alarms

~~shall be required~~

- a. for systems used for the piping of nonflammable medical gases.

- (5) ~~Mechanical, control, and other accessories required for effective life safety systems operation shall be permitted to be connected to the life safety branch.~~

- (6) Communications systems for the following:

- (7) Communications systems, where used for issuing instructions during emergency conditions [99: 6.7.5.1.2.2(3)]

~~Where used, emergency~~

- a. Emergency responder radio communication systems (ERRCs)

- (8) ~~Generator set locations~~ On-site power source locations , as follows:

- (9) Task illumination

- (10) Battery charger for emergency battery-powered lighting unit(s)

~~Select~~

- a. Selected receptacles at the

~~generator set location~~

- a. on-site power source location and essential electrical system transfer switch locations

[99: 6.7.5.1.2.2(4)]

- (11) Elevator cab lighting, control, communications, and signal systems [99:6.7.5.1.2.2(5)]

- (12) Electrically powered doors used for building egress [99:6.7.5.1.2.2(6)]

(B) Illumination of Means of Egress.

Switching arrangements to transfer patient corridor lighting in hospitals from general illumination circuits to night illumination circuits shall be permitted if only one of two circuits can be selected and both circuits cannot be extinguished at the same time.

(C) ~~Generator Set~~ On-Site Power Source Accessories.

Loads dedicated to ~~a specific generator~~ on-site power sources, including the fuel transfer pump(s), ventilation fans, electrically operated louvers, controls, cooling system, and other ~~generator accessories~~ on-site power source accessories essential for ~~generator operation on-site power source operation~~, shall be connected to the life safety branch or the output terminals of the ~~generator with~~ on-site power source with overcurrent protective devices.

[~~99: 6.7.5.1.2.4~~]

(D) Mechanical, control and other accessories required for effective life safety systems operation shall be permitted to be connected to the life safety branch.

Statement of Problem and Substantiation for Public Comment

The proposed changes address a number of concerns. The following is a list of proposed changes with explanations for each.

Reverts back to section name Life Safety Branch (the requirement for Automatic connection is included in 517.32 and need not be repeated here)

Reverts back to the previous charging station which allow for a list (A)-(D) which all relate to the Life Safety Branch.

(3) a. Change "Fire Alarm systems shall be required" to "Fire Alarm Systems"

This is a list of loads that need to be connected to the life safety branch, this is not the place to require fire alarm systems to be installed

(3) b. Next on the list is Alarm and alerting systems (adding "be permitted" to show item on the list has the choice of either connecting to the life safety branch or the critical branch. I propose to add this to the list as a separate item with this statement rather than include in list of alarm and alerting systems required to be connected to the life safety branch.

(3) c. Change "Alarms shall be required for systems used for the piping of non flammable medical gases" to "Alarms for systems ..."

This is a list of loads that need to be connected to the life safety branch, this is not the place to require alarm systems for medical gases.

(3) d. Remove from this list and add as separated paragraph (D) at the end of this section.

This is a list of loads that need to be connected to the life safety branch, and so does not appear to be the correct place to give permissive language for mechanical, control and other accessories required for effective life safety systems operation (if required remove the permissive language). We felt that this is better located as a

(4) b. Remove "Where used," so just lists the ERRC system

(5) Change "Generator set locations" to "On-site power source locations, ..."

Revise to allow for other on-site power sources than generators (note emergency generators would qualify as on-site power sources

5(c) Select receptacles at the generator set location.. <change to> Selected receptacles at the on-site power source location....

Grammar fix from select to selected and revise to allow for other on-site power sources than generators (note emergency generators would qualify as on-site power sources (Microgrid task group item)

-and-

Delete NFPA 99 reference as this no longer is valid.

(C) Revise to remove the word generator and to replace with on-site power source in multiple locations to allow for other on-site power sources other than generators (note emergency generators would qualify as on-site power sources (Microgrid task force items)

-and-

Delete NFPA 99 reference as this no longer is valid.

Related Item

- FR-9029/PI-2114/PI-2981/PI-3595/PI-3596

Submitter Information Verification

Submitter Full Name: Jamie Schnick

Organization: HCAI/OSHPD

Affiliation: State of California

Street Address:

City:

State:

Zip:

Submittal Date: Tue Aug 13 14:52:48 EDT 2024

Committee: NEC-P15



Public Comment No. 662-NFPA 70-2024 [Section No. 517.33]

517.33 Automatic Connection to Life Safety Branch.

(A) Life Safety Branch.

The life safety branch shall be limited to circuits essential to life safety. [99:6.7.5.1.2.1]

No functions other than those listed in 517.33(A)(1) through 517.33(A)(7) shall be connected to the life safety branch. The life safety branch shall supply power as follows:

- (1) Illumination of means of egress such as lighting required for corridors, passageways, stairways, and landings at exit doors, and all necessary ways of approach to exits
Informational Note: See NFPA 101-2024, *Life Safety Code*, Sections 7.8 and 7.9.
- (2) Exit signs and exit directional signs
Informational Note: See NFPA 101-2024, *Life Safety Code*, Section 7.10.
- (3) Alarm and alerting systems, as follows:
 - a. Fire alarm systems shall be required.
 - b. Alarm and alerting systems (other than fire alarm systems) shall be connected to the life safety branch or critical branch. [99:6.7.5.1.2.3]
 - c. Alarms shall be required for systems used for the piping of nonflammable medical gases.
 - d. Mechanical, control, and other accessories required for effective life safety systems operation shall be permitted to be connected to the life safety branch.
- (4) Communications systems for the following:
 - a. Communications systems, where used for issuing instructions during emergency conditions [99:6.7.5.1.2.2(3)]
 - b. Where used, emergency responder radio communication systems (ERRCs)
- (5) Generator set locations, as follows:
 - a. Task illumination
 - b. Battery charger for emergency battery-powered lighting unit(s)
 - c. Select receptacles at the generator set location and essential electrical system transfer switch locations
[99:6.7.5.1.2.2(4)]
- (6) Elevator cab lighting, control, communications, and signal systems [99:6.7.5.1.2.2(5)]
- (7) Electrically powered doors used for building egress [99:6.7.5.1.2.2(6)]

(B) Illumination of Means of Egress.

Switching arrangements to transfer patient corridor lighting in hospitals from general illumination circuits to night illumination circuits shall be permitted if only one of two circuits can be selected and both circuits cannot be extinguished at the same time.

(C) Generator Set Accessories.

Loads dedicated to a specific generator, including the fuel transfer pump(s), ventilation fans, electrically operated louvers, controls, cooling system, and other generator accessories essential for generator operation, shall be connected to the life safety branch or the output terminals of the generator with overcurrent protective devices. [99:6.7.5.1.2.4]

Additional Proposed Changes

<u>File Name</u>	<u>Description</u>	<u>Approved</u>
CN_365.pdf		

Statement of Problem and Substantiation for Public Comment

NOTE: The following CC Note No. 365 appeared in the First Draft Report on First Revision No. 9240, First Revision No. 9029, First Revision No. 9229 and First Revision No. 9100.

These two sections, 517.33 and 517.43, are both titled "Automatic Connection to Life Safety Branch". CMP 15 should review the sections and select appropriate titles including "in Type 1 Locations" or "in Type 2 locations" as applicable to improved usability.

Related Item

• First Revision No. 9240 • First Revision No. 9029 • First Revision No. 9229 • First Revision No. 9100

Submitter Information Verification

Submitter Full Name: CC Notes

Organization: NEC Correlating Committee

Street Address:

City:

State:

Zip:

Submittal Date: Fri Aug 02 09:43:35 EDT 2024

Committee: NEC-P15



Correlating Committee Note No. 365-NFPA 70-2024 [Section No. 517.33]

Submitter Information Verification

Committee: NEC-AAC

Submittal Date: Fri May 10 09:53:33 EDT 2024

Committee Statement

Committee Statement: These two sections, 517.33 and 517.43, are both titled “Automatic Connection to Life Safety Branch”. CMP 15 should review the sections and select appropriate titles including “in Type 1 Locations” or “in Type 2 locations” as applicable to improved usability.

[First Revision No. 9240-NFPA 70-2024 \[Global Input\]](#)

[First Revision No. 9029-NFPA 70-2024 \[Detail\]](#)

[First Revision No. 9229-NFPA 70-2024 \[Global Input\]](#)

[First Revision No. 9100-NFPA 70-2024 \[Detail\]](#)

Ballot Results

✔ **This item has passed ballot**

12 Eligible Voters

1 Not Returned

11 Affirmative All

0 Affirmative with Comments

0 Negative with Comments

0 Abstention

Not Returned

McDaniel, Roger D.

Affirmative All

Ayer, Lawrence S.

Bowmer, Trevor N.

Hickman, Palmer L.

Holub, Richard A.

Jackson, Peter D.

Kendall, David H.

Manche, Alan

Osborne, Robert D.

Porter, Christine T.

Schultheis, Timothy James

Williams, David A.



Public Comment No. 1165-NFPA 70-2024 [Section No. 517.35(A)]

(A) Equipment for Delayed Automatic Connection.

The following equipment shall be permitted to be arranged for delayed-automatic connection to the on-site power source:

- (1) Central suction systems serving medical and surgical functions, including controls, with such suction systems permitted to be placed on the critical branch
- (2) Sump pumps and other equipment required to operate for the safety of major apparatus, including associated control systems and alarms
- (3) Compressed air systems serving medical and surgical functions, including controls, with such air systems permitted to be placed on the critical branch
- (4) Smoke control and stair pressurization systems
- (5) Kitchen hood supply or exhaust systems, or both, if required to operate during a fire in or under the hood
- (6) Supply, return, and exhaust ventilating systems for the following:
 - (7) Airborne infectious/isolation rooms
 - (8) Protective environment rooms
 - (9) Exhaust fans for laboratory fume hoods
 - (10) Nuclear medicine areas where radioactive material is used
 - (11) Ethylene oxide evacuation
 - (12) Anesthetic evacuation

[99:6.7.5.1.4.3(A)]

Where delayed-automatic connection is not appropriate, the ventilation systems specified in 517.35(A)(6) shall be permitted to be placed on the critical branch. [99:6.7.5.1.4.3(B)]

- (13) Supply, return, and exhaust ventilating systems for operating and delivery rooms
- (14) Supply, return, exhaust ventilating systems and/or air-conditioning systems serving telephone equipment rooms and closets and data equipment rooms and closets

Statement of Problem and Substantiation for Public Comment

It appears that FR-9035 removed the last 2 items in list of equipment required to be connected to the equipment branch - items:

7) Supply, return, and exhaust ventilating systems for operating and delivery rooms
-and-

(8) Supply, return, exhaust ventilating systems and/or air-conditioning systems serving telephone equipment rooms and closets and data equipment rooms and closets

These 2 requirements were in the 2014 NEC and all subsequent codes to date (in this location). Removing from the code at this time could result in the following:

- Inability to maintain pressure differentials and intern maintain infection control in the OR and delivery rooms during a power outage
- Inability to maintain temperature control of in spaces that house headend of low voltage systems

serving life safety and patient care needs, which could result in the destruction of sensitive electronic equipment (servers and associated equipment).

I recommend that the if it was the intention to remove these 2 items that supporting documentation be developed for consideration, and in the meanwhile the code be returned to original condition.

Related Item

- FR-9035

Submitter Information Verification

Submitter Full Name: Jamie Schnick
Organization: HCAI/OSHPD
Affiliation: CA Department of Health Care Access and Information/Office of Hospital Planning and Development
Street Address:
City:
State:
Zip:
Submittal Date: Fri Aug 16 10:57:05 EDT 2024
Committee: NEC-P15



Public Comment No. 1287-NFPA 70-2024 [Section No. 517.35(B)]

(B) Equipment for Delayed Automatic or Manual Connection.

The following equipment shall be permitted to be arranged for either delayed-automatic or manual connection to the on-site power source:

- (1) Heating equipment used to provide heating for operating, delivery, labor, recovery, intensive care, and coronary care spaces; nurseries; infection/isolation rooms; emergency treatment spaces; and general patient rooms and pressure maintenance (i.e., jockey or make-up) pumps for water-based fire protection systems [99:6.7.5.1.4.4(1)]

Exception: Heating of general patient rooms and infection/isolation rooms during disruption of the normal source shall not be required under any of the following conditions:

- (1) *The outside design temperature is higher than -6.7°C (20°F).*
- (2) *The outside design temperature is lower than -6.7°C (20°F), and where a selected room(s) is provided for the needs of all confined patients, only such room(s) need be heated.*
- (3) *The facility is served by a dual source of normal power.*

Informational Note No. 1: See ASHRAE *Handbook on Fundamentals* (2013) Chapter 24, which shows the outside design temperature is based on the 97.5 percent design values.

Informational Note No. 2: See 517.30(D) for a description of a dual source of normal power.

- (2) Elevator(s) selected to provide service to patient, surgical, obstetrical, and ground floors during interruption of normal power [99:6.7.5.1.4.4(3)]
- (3) Supply, return, and exhaust ventilating systems for surgical and obstetrical delivery suites; intensive care and coronary care spaces; nurseries; and emergency treatment spaces [99:6.7.5.1.4.4(4)]
- (4) Hyperbaric facilities [99:6.7.5.1.4.4(5)]
- (5) Hypobaric facilities [99:6.7.5.1.4.4(6)]
- (6) ~~Automatically operated doors~~
- (7) Autoclaving equipment, which is permitted to be arranged for either automatic or manual connection to the alternate source [99: 6.7.5.1.4.4(7)]
- (8) Controls for equipment listed in 517.35 [99:6.7.5.1.4.4(8)]
- (9) Other selected equipment [99:6.7.5.1.4.4(9)]

Statement of Problem and Substantiation for Public Comment

Section 517.33(H) requires "Auto doors" to be connected to the life safety branch. Having the requirement for "Automatically operated doors" to be connected to the equipment branch is a contradiction. It appears that this is a mistake. I recommend that this requirement be removed from 517.35. Please note: NFPA 70 (NEC) fell out of alignment with NFPA 99 around 1999. Prior to that date NFPA 99 had automatically operated doors listed under the Equipment Branch of the Essential Electrical System. It appears that this was added to 517.33 to align with NFPA 99, but for some reason the requirement was not removed from 517.35 at that time.

Note the NFPA Health Care Facilities Handbook provides clarification of what became Section

4.4.2.2.2(7) in the 2002 Edition: “This text, concerning automatically operated doors was removed from the equipment system and added to the life safety branch in 1999 because the committee believes that this requirement is related to life safety and that service needs to be restored in 10 seconds. The general public is not generally familiar with the manual operation of automatic doors under emergency conditions.” NFPA 99 then dropped it from their list under 4.4.2.2.3.5. The NEC, while picking up the new language under Article 517.33 (H), failed the follow through on that move and left the old language under Article 517.35 (B)(5), thus essentially having it in two places although they were intended to refer to the same thing. This has the effect of designers and building officials trying to guess what the difference is when there wasn’t supposed to be a difference. It was only supposed to be moved from one location to another.

Related Item

- FR-9035

Submitter Information Verification

Submitter Full Name: Jamie Schnick
Organization: HCAI/OSHPD
Affiliation: CA Department of Health Care Access and Information/Office of Hospital Planning and Development
Street Address:
City:
State:
Zip:
Submittal Date: Mon Aug 19 17:52:08 EDT 2024
Committee: NEC-P15



Public Comment No. 1873-NFPA 70-2024 [Section No. 517.41(A)]

(A) Independent Power Sources.

~~EES- Essential Electrical System~~ loads shall be served by two or more independent power sources (or sets of sources). ~~One source (or sets of sources)- power sources and sets of feeders designed to ensure sufficient reliability to provide effective facility operation consistent with the facility's emergency operations plan. At least one power source shall be on-site power production equipment, storage components, or a combination- and sized to supply the entire EES- essential electrical system. The additional power source(s) shall be permitted to be either on-site or off-site.~~

Informational Note: An example of a set of sources may be several generators that when combined serve the entire EES.

Statement of Problem and Substantiation for Public Comment

This comment is submitted by the NFPA70-99 Task Force on Microgrids. This comment aligns language between the two documents. It is not a technical change, merely an editorial change to make it easier to use the two documents, with similar language. It cannot be an extract (this cycle) as the 99 changes have not yet been finally approved.

Related Item

- 9042

Submitter Information Verification

Submitter Full Name: Walter Vernon
Organization: Mazzetti
Affiliation: NFPA 70-99 Microgrids task Force
Street Address:
City:
State:
Zip:
Submittal Date: Tue Aug 27 19:23:35 EDT 2024
Committee: NEC-P15



Public Comment No. 1298-NFPA 70-2024 [Section No. 517.42(B)]

(B) Transfer Switches.

The number of transfer switches to be used shall be based upon reliability, design, and load considerations. [99:6.7.2.2.3]

Transfer switches shall comply with one of the following:

- (1) Each branch of the essential electrical system shall have one or more transfer switches. [99:6.7.2.2.3.1]
- (2) One transfer switch shall be permitted to serve one or more branches in a facility with a continuous essential electrical system load ~~on the switch~~ of 150 kVA (120 kW) or less. [99:6.7.2.2.3.2]

Informational Note No. 1: See NFPA 99-2024, *Health Care Facilities Code*, 6.7.2.2.4, 6.7.2.2.5, 6.7.2.2.5.15, and 6.7.2.2.7 for more information on transfer switches.

Informational Note No. 2: See Figure Informational Note 517.42(B)(1).

Informational Note No. 3: See Figure Informational Note 517.42(B)(2).

Figure Informational Note 517.42(B)(1) Type 2 EESs (Nursing Home and Limited Health Care Facilities) — Minimum Requirement (Greater Than 150 kVA) for Transfer Switch Arrangement.

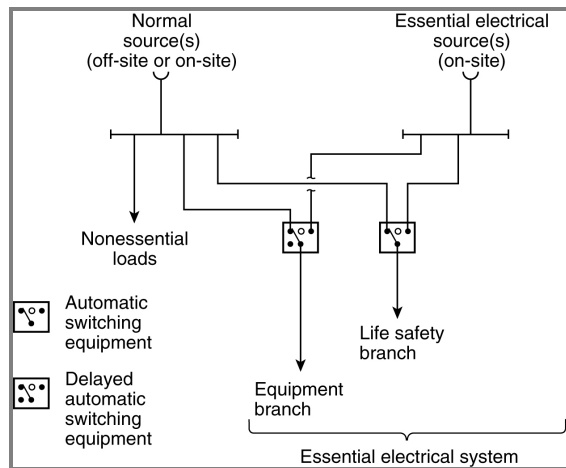
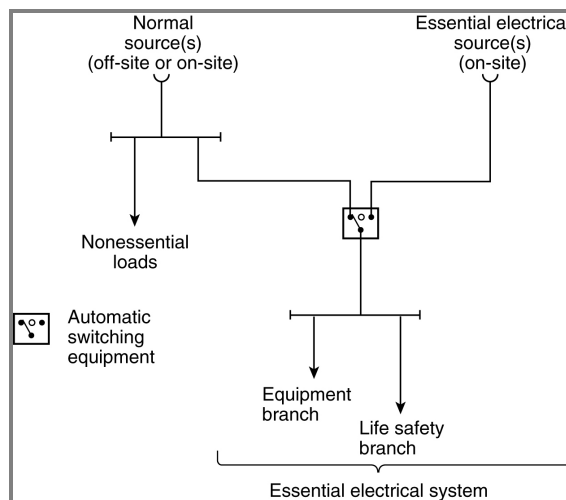

Figure Informational Note 517.42(B)(2) Type 2 EESs (Nursing Home and Limited Health Care Facilities) — Minimum Requirement (150 kVA or Less) for Transfer Switch Arrangement.



The original PI attempts to correct some language that could be misinterpreted to mean it is permissible to use multiple transfer switches that mix the branches as long as the load in each transfer switch is kept below 150kVA. The intent is to allow smaller facilities with small essential electrical systems to not have to divide the EES into separate branches. However, since the requirement is written based on the load on the transfer switch and not the total EES load, it could be allowable to mix the branches on a very large EES as long as the load on each individual transfer switch was kept below 150kVA. This could compromise the safety and reliability of key systems directly related to life safety and patient care.

This has also been proposed in NFPA 99 for correction. The challenge is that the NFPA 99 cycle trails the NFPA 70 cycle by one year. Since this is extracted language, it will automatically be updated once NFPA 99 is published. However, that would mean this incorrect language may remain in NFPA 70 until 2029. This comment attempts to reopen this discussion for the committee to consider the best path to correct this issue for both Type 1 EES (517.31(B)) and Type 2 EES (517.42(B)).

Related Public Comments for This Document

<u>Related Comment</u>	<u>Relationship</u>
<u>Public Comment No. 1068-NFPA 70-2024 [Section No. 517.31(B) [Excluding any Sub-Sections]]</u>	Same comment for Type 1 EES
<u>Public Comment No. 1068-NFPA 70-2024 [Section No. 517.31(B) [Excluding any Sub-Sections]]</u>	

Related Item

- PI 2110

Submitter Information Verification

Submitter Full Name: Chris Finen
Organization: Eaton Corporation
Street Address:
City:
State:
Zip:
Submittal Date: Tue Aug 20 12:49:57 EDT 2024
Committee: NEC-P15



Public Comment No. 1771-NFPA 70-2024 [Section No. 517.42(D)]

(D) Separation from Other Circuits.

The life safety branch and equipment branch shall be kept entirely independent of all other wiring and equipment. [99:6.7.6.3.1]

(a)

Raceways, cables, or enclosures of the life safety and equipment branch shall be readily identified as components of the essential electrical system (EES). Boxes and enclosures (including transfer switches, generators, and power panels) shall be field- or factory-marked and identified as components of the EES. Raceways and cables shall be field- or factory-marked as components of the EES at intervals not to exceed 7.6 m (25 ft).

(b)

These circuits shall not enter the same raceways, boxes, or cabinets with other wiring except as follows:

- (1) In transfer switches
- (2) In exit or emergency luminaires supplied from two sources
- (3) In a common junction box attached to exit or emergency luminaires supplied from two sources

Statement of Problem and Substantiation for Public Comment

FR-8982 proposes to remove the requirement to comply with Article 700, which would result in the loss of requirement for Type 2 essential electrical systems to mark and identify components of the EES. This P.C. adds this requirement back into 517. Note the previous requirement was for life safety only, but with the understanding that for type 2 EES's the equipment branch serves as both the critical (patient care) and equipment branch (equipment), it would be appropriate for both branches be required to have a means of identification. Note the text proposed to be added here is copied verbatim from 517.31(C)(1) - requirements for identification of Type 1 systems

Related Item

- FR-8982

Submitter Information Verification

Submitter Full Name: Jamie Schnick
Organization: HCAI/OSHPD
Affiliation: CA Department of Health Care Access and Information/Office of Hospital Planning and Development
Street Address:
City:
State:
Zip:
Submittal Date: Tue Aug 27 09:55:04 EDT 2024
Committee: NEC-P15



Public Comment No. 1177-NFPA 70-2024 [Section No. 517.43]

517.43 Automatic Connection to Life Safety Branch.

(A) Life Safety Branch.

The life safety ~~branches shall~~ branch shall be installed and connected to the on-site power specified in 517.41 so that all functions specified herein for the life safety ~~branches are~~ branch are automatically restored to operation within 10 seconds after interruption of power. [99:6.7.6.4.1]

No functions other than those listed in 517.43(B)(1) through 517.43(B)(6) shall be connected to the life safety branch. [99:6.7.6.2.1.5(B)]

The life safety branch shall supply power as follows:

- (1) Illumination of means of egress as is necessary for corridors, passageways, stairways, landings, and exit doors and all ways of approach to exits

Informational Note: See NFPA 101-2024, *Life Safety Code*, Sections 7.8 and 7.9.

- (2) Exit signs and exit directional signs

Informational Note: See NFPA 101-2024, *Life Safety Code*, Section 7.10 and NFPA 99-2024, *Health Care Facilities Code*, 6.7.6.2.1.5(2).

- (3) Alarm and alerting systems, including the following:

- (4) Fire alarms

Informational Note No. 1: See NFPA 99-2024, *Health Care Facilities Code*, 6.7.6.2.1.5(3)(a).

- (5) Alarms required for systems used for the piping of nonflammable medical gases

Informational Note No. 2: See NFPA 99-2024, *Health Care Facilities Code*, 6.7.5.1.2.5.

- (6) Communications systems for the following:

- a. Communications systems, where used for issuing instructions during emergency conditions [99:6.7.6.2.1.5(A)(3)]
- b. Emergency responder radio communication systems (ERRCs)

- (7) Task illumination and select receptacles at the generator set location and essential electrical system transfer switch locations

- (8) Elevator cab lighting, control, communications, and signal systems [99:6.7.6.2.1.5(A)(6)]

- (9) Equipment for Nondelayed-Automatic Connection. Generator accessories including, but not limited to, the transfer fuel pump, electrically operated louvers, and other generator accessories essential for generator operation shall be arranged for automatic connection to the on-site power source.

(B) Illumination of Means of Egress.

Switching arrangement to transfer patient corridor lighting from general illumination circuits shall be permitted if only one of two circuits can be selected and both circuits cannot be extinguished at the same time.

Statement of Problem and Substantiation for Public Comment

I also propose to revise "life safety branches" to "life safety branch" in 2 locations to correct grammar.
-and-

FR-9094 has moved the requirement for the generator accessories from the life safety branch to the equipment branch, but did not provide any substantiating back-up for this significant change. This is problematic for 2 reasons:

1) If the generator accessories are fed by the equipment branch, they would be at a lower priority than the life safety loads that the generator feeds. That is to say that you could have a condition where the generator and life safety branch are fully operational but could not provide power to life safety loads because the lower priority equipment branch is not functioning properly.

2) If transferred to the equipment branch with the requirement for non-delayed connection, this would be the only load required to be on the equipment branch that is required to be connected without delay, the concept of a single ATS for equipment branch that is allowed to be delayed will not be able to be used to help reduce the size of emergency generators.

I propose that we keep the current language of the NEC which requires feeds to generator accessories via life safety.

Related Item

- FR-9094

Submitter Information Verification

Submitter Full Name: Jamie Schnick
Organization: HCAI/OSHPD
Affiliation: CA Department of Health Care Access and Information/Office of Hospital Planning and Development
Street Address:
City:
State:
Zip:
Submittal Date: Fri Aug 16 12:39:54 EDT 2024
Committee: NEC-P15



Public Comment No. 665-NFPA 70-2024 [Section No. 517.43]

517.43 Automatic Connection to Life Safety Branch.

(A) Life Safety Branch.

The life safety branches shall be installed and connected to the on-site power specified in 517.41 so that all functions specified herein for the life safety branches are automatically restored to operation within 10 seconds after interruption of power. [99:6.7.6.4.1]

No functions other than those listed in 517.43(B)(1) through 517.43(B)(6) shall be connected to the life safety branch. [99:6.7.6.2.1.5(B)]

The life safety branch shall supply power as follows:

- (1) Illumination of means of egress as is necessary for corridors, passageways, stairways, landings, and exit doors and all ways of approach to exits

Informational Note: See NFPA 101-2024, *Life Safety Code*, Sections 7.8 and 7.9.

- (2) Exit signs and exit directional signs

Informational Note: See NFPA 101-2024, *Life Safety Code*, Section 7.10 and NFPA 99-2024, *Health Care Facilities Code*, 6.7.6.2.1.5(2).

- (3) Alarm and alerting systems, including the following:

- a. Fire alarms

Informational Note No. 1: See NFPA 99-2024, *Health Care Facilities Code*, 6.7.6.2.1.5(3)(a).

- b. Alarms required for systems used for the piping of nonflammable medical gases

Informational Note No. 2: See NFPA 99-2024, *Health Care Facilities Code*, 6.7.5.1.2.5.

- (4) Communications systems for the following:

- a. Communications systems, where used for issuing instructions during emergency conditions [99:6.7.6.2.1.5(A)(3)]

- b. Emergency responder radio communication systems (ERRCs)

- (5) Task illumination and select receptacles at the generator set location and essential electrical system transfer switch locations

- (6) Elevator cab lighting, control, communications, and signal systems [99:6.7.6.2.1.5(A)(6)]

(B) Illumination of Means of Egress.

Switching arrangement to transfer patient corridor lighting from general illumination circuits shall be permitted if only one of two circuits can be selected and both circuits cannot be extinguished at the same time.

Additional Proposed Changes

<u>File Name</u>	<u>Description</u>	<u>Approved</u>
CN_366.pdf		

Statement of Problem and Substantiation for Public Comment

NOTE: The following CC Note No. 366 appeared in the First Draft Report on First Revision No. 9240, First Revision No. 9029, First Revision No. 9229 and First Revision No. 9100.

These two sections, 517.33 and 517.43, are both titled "Automatic Connection to Life Safety Branch". CMP 15 should review the sections and select appropriate titles including "in Type 1 Locations" or "in Type 2 locations" as applicable to improved usability.

Related Item

• First Revision No. 9240 • First Revision No. 9029 • First Revision No. 9229 • First Revision No. 9100

Submitter Information Verification

Submitter Full Name: CC Notes

Organization: NEC Correlating Committee

Street Address:

City:

State:

Zip:

Submittal Date: Fri Aug 02 10:16:25 EDT 2024

Committee: NEC-P15



Correlating Committee Note No. 366-NFPA 70-2024 [Section No. 517.43]

Submitter Information Verification

Committee: NEC-AAC

Submittal Date: Fri May 10 09:54:25 EDT 2024

Committee Statement

Committee Statement: These two sections, 517.33 and 517.43, are both titled “Automatic Connection to Life Safety Branch”. CMP 15 should review the sections and select appropriate titles including “in Type 1 Locations” or “in Type 2 locations” as applicable to improved usability.

[First Revision No. 9240-NFPA 70-2024 \[Global Input\]](#)

[First Revision No. 9029-NFPA 70-2024 \[Detail\]](#)

[First Revision No. 9229-NFPA 70-2024 \[Global Input\]](#)

[First Revision No. 9100-NFPA 70-2024 \[Detail\]](#)

Ballot Results

✔ **This item has passed ballot**

12 Eligible Voters

1 Not Returned

11 Affirmative All

0 Affirmative with Comments

0 Negative with Comments

0 Abstention

Not Returned

McDaniel, Roger D.

Affirmative All

Ayer, Lawrence S.

Bowmer, Trevor N.

Hickman, Palmer L.

Holub, Richard A.

Jackson, Peter D.

Kendall, David H.

Manche, Alan

Osborne, Robert D.

Porter, Christine T.

Schultheis, Timothy James

Williams, David A.



Public Comment No. 1180-NFPA 70-2024 [Section No. 517.44]

517.44 Connection to Equipment Branch.

The equipment branch shall be installed and connected to the on-site power source such that equipment described in 517.44(B A) is automatically restored to operation at appropriate time-lag intervals following the energizing of the life safety branches. [99:6.7.5.1.4.2(A)]

The equipment branch arrangement shall also provide for the additional connection of equipment listed in 517.44(G B).

Exception: For essential electrical systems under 150 kVA, deletion of the time-lag intervals feature for delayed automatic connection to the equipment branch shall be permitted.

~~(B)~~

~~(A) ac Equipment for Nondelayed Automatic Connection:~~

~~Generator accessories including, but not limited to, the transfer fuel pump, electrically operated louvers, and other generator accessories essential for generator operation shall be arranged for automatic connection to the on-site power source. [99: 6.7.6.2.1.6(C)]~~

Delayed Automatic Connections to Equipment Branch.

The following equipment shall be permitted to be connected to the equipment branch and shall be arranged for delayed-automatic connection to the on-site power source:

- (1) Task illumination and select receptacles in the following:
 - (2) Patient care spaces
 - (3) Medication preparation spaces

 - (4) Pharmacy dispensing space
 - (5) Nurses' stations — unless adequately lighted by corridor luminaires
- (6) Supply, return, and exhaust ventilating systems for airborne infectious isolation rooms
- (7) Sump pumps and other equipment required to operate for the safety of major apparatus and associated control systems and alarms
- (8) Smoke control and stair pressurization systems
- (9) Kitchen hood supply or exhaust systems, or both, if required to operate during a fire in or under the hood
- (10) Nurse call systems
- (11) HVAC systems serving the EF, TER, and TR

[99:6.7.6.2.1.6(D)]

~~(G B)~~ Delayed-Automatic or Manual Connection to the Equipment Branch.

The equipment specified in 517.44(C)(1) through 517.44(C)(4) shall be permitted to be connected to the equipment branch and shall be arranged for either delayed-automatic or manual connection to the alternate power source. [99:6.7.6.2.1.6(E)]

(1) Heating Equipment to Provide Heating for General Patient Rooms.

Heating of general patient rooms during disruption of the normal source shall not be required under any of the following conditions:

- (1) The outside design temperature is higher than -6.7°C (20°F).
- (2) The outside design temperature is lower than -6.7°C (20°F) and, where a selected room(s) is provided for the needs of all confined patients, then only such room(s) need be heated.
- (3) The facility is served by a dual source of normal power as described in 517.30(D) Informational Note.

[99:6.7.6.2.1.6(E)(1)]

Informational Note: See ASHRAE *Handbook of Fundamentals* (2021), Chapter 24, which shows the outside design temperature is based on the 97.5 percent design values.

(2) Elevator Service.

In instances where interruptions of power would result in elevators stopping between floors, throw-over facilities shall be provided to allow the temporary operation of any elevator for the release of passengers. [99:6.7.6.2.1.6(E)(2)]

(3) Optional Connections to the Equipment Branch.

Additional illumination, receptacles, and equipment shall be permitted to be connected only to the equipment branch. [99:6.7.6.2.1.6(E)(3)]

(4) Multiple Systems.

Where one switch serves multiple systems as permitted in 517.43, transfer for all loads shall be nondelayed automatic. [99:6.7.6.2.1.6(E)(4)]

Informational Note: See 517.44(A) for elevator cab lighting, control, and signal system requirements. [99:A.6.7.6.2.1.6(E)(2)]

Statement of Problem and Substantiation for Public Comment

FR-9227 proposes to move the requirement for the generator accessories from the life safety branch to the equipment branch [ie delete from 517.43(G)]. This is problematic for 2 reasons:

- 1) If the generator accessories are fed by the equipment branch, they would be at a lower priority than the life safety loads that the generator feeds. That is to say that you could have a condition where the generator and life safety branch are fully operational but could not provide power to life safety loads because the lower priority equipment branch is not functioning properly.
- 2) If transferred to the equipment branch with the requirement for non-delayed connection, this would be the only load required to be on the equipment branch that is required to be connected without delay, the concept of a single ATS for equipment branch that is allowed to be delayed will not be able to be used to help reduce the size of emergency generators.

I propose that we keep the current language of the NEC which requires feeds to generator accessories via life safety

Related Item

- PR-9227, PR-9094 & PI-2156

Submitter Information Verification

Submitter Full Name: Jamie Schnick
Organization: HCAI/OSHPD
Affiliation: CA Department of Health Care Access and Information/Office of Hospital Planning and Development
Street Address:
City:
State:

Zip:

Submittal Date: Fri Aug 16 13:24:21 EDT 2024

Committee: NEC-P15



Public Comment No. 1288-NFPA 70-2024 [Section No. 517.44]

517.44 Connection to Equipment Branch.

The equipment branch shall be installed and connected to the on-site power source such that equipment ~~described in~~ listed in 517.44(B A) is automatically restored to operation at appropriate time-lag intervals following the ~~energizing~~ restoration of the life safety ~~branches~~ branch to operation. [99:6.7.5 6 .1.4.2 6 (A)]

The equipment branch arrangement shall also provide for the additional connection of equipment listed in 517.44(C B).

Exception: For essential electrical systems under 150 kVA, deletion of the time-lag intervals feature for delayed automatic connection to the equipment branch shall be permitted.

~~(B)~~

~~(A)~~

~~ac Equipment for Nondelayed Automatic Connection:~~

~~Generator accessories including, but not limited to, the transfer fuel pump, electrically operated louvers, and other generator accessories essential for generator operation shall be arranged for automatic connection to the on-site power source. [99: 6.7.6.2.1.6(C)]~~

~~**Delayed Automatic Connections to Equipment Branch.**~~

~~The following equipment shall be permitted to be connected to the equipment branch and shall be arranged for delayed-automatic connection to the on-site power source:~~

- ~~(1) - Task illumination and select receptacles in the following:~~
 - ~~(2) Patient care spaces~~
 - ~~(3) Medication preparation spaces~~

 - ~~(4) Pharmacy dispensing space~~
 - ~~(5) Nurses' stations — unless adequately lighted by corridor luminaires~~

- ~~(6) - Supply, return, and exhaust ventilating systems for airborne infectious isolation rooms~~
- ~~(7) - Sump pumps and other equipment required to operate for the safety of major apparatus and associated control systems and alarms~~
- ~~(8) - Smoke control and stair pressurization systems~~
- ~~(9) - Kitchen hood supply or exhaust systems, or both, if required to operate during a fire in or under the hood~~
- ~~(10) - Nurse call systems~~
- ~~(11) - HVAC systems serving the EF, TER, and TR~~

~~[99: 6.7.6.2.1.6(D)]~~

~~f~~

~~g~~

~~**B)- Delayed-Automatic or Manual Connection to the Equipment Branch.**~~

~~The equipment specified in 517.44(~~

~~g~~

~~B)(1) through 517.44(~~

~~g~~

~~B)(4) shall be permitted to be connected to the equipment branch and shall be arranged for either delayed-automatic or manual connection to the alternate power source.~~

~~[99: 6.7.6.2.1.6(E)]~~

~~(1) Heating Equipment to Provide Heating for General Patient Rooms:~~

~~Heating of general patient rooms during disruption of the normal source shall not be required under any of the following conditions:~~

- ~~(1) The outside design temperature is higher than 6.7°C (20°F).~~
- ~~(2) The outside design temperature is lower than 6.7°C (20°F) and, where a selected room(s) is provided for the needs of all confined patients, then only such room(s) need be heated.~~
- ~~(3) The facility is served by a dual source of normal power as described in 517.30(~~

~~D~~

- ~~(1) G) Informational Note:~~

~~[99: 6.7.6.2.1.6(E)(1)]~~

~~Informational Note: See ASHRAE *Handbook of Fundamentals* (2021), Chapter 24, which shows the outside design temperature is based on the 97.5 percent design values.~~

~~(2) Elevator Service:~~

~~In instances where interruptions of power would result in elevators stopping between floors, throw-over facilities shall be provided to allow the temporary operation of any elevator for the release of passengers. [99: 6.7.6.2.1.6(E)(2)]~~

~~(3) Optional Connections to the Equipment Branch:~~

~~Additional illumination, receptacles, and equipment shall be permitted to be connected only to the equipment branch. [99: 6.7.6.2.1.6(E)(3)]~~

~~(4) Multiple Systems:~~

~~Where one switch serves multiple systems as permitted in 517:~~

~~43~~

~~44(F) , transfer for all loads shall be nondelayed automatic. [99: 6.7.6.2.1.6(E)(4)]~~

~~Informational Note: See 517.~~

~~44~~

~~43 (A) (6) - for elevator cab lighting, control, and signal system requirements.~~

~~[99: A.6.7.6.2.1.6(E)(2)]~~

~~-~~

Statement of Problem and Substantiation for Public Comment

FR-9227 relocated the circuiting requirements from life safety to the equipment branch, which could be problematic. Note if the generator is functioning and feeding life safety loads, if the lower priority equipment branch fails, this could cause the generator to shutoff because of lack of fuel, high temps etc... By feeding these generator accessories from the life safety branch, we will ensure that when the generator and life safety branches are fully functional that the system can operate continuously. This removal required renumbering for paragraphs ie B - A etc.. Some extracts tagged in this section do not match NFPA 99 text, this PC fixes the incorrect references and wording of NFPA 99 extracts, so they now match.

Related Item

- FR-9227

Submitter Information Verification

Submitter Full Name: Jamie Schnick
Organization: HCAI/OSHPD
Affiliation: CA Department of Health Care Access and Information/Office of Hospital Planning and Development
Street Address:
City:
State:
Zip:
Submittal Date: Mon Aug 19 17:55:50 EDT 2024
Committee: NEC-P15



Public Comment No. 680-NFPA 70-2024 [Section No. 517.60]

517.60 General.

Inhalation anesthetizing locations shall comply with Article 517, Part IV.

Informational Note: See NFPA 99-2024, *Health Care Facilities Code*, for further information regarding safeguards for anesthetizing locations.

Additional Proposed Changes

<u>File Name</u>	<u>Description</u>	<u>Approved</u>
CN_381.pdf		

Statement of Problem and Substantiation for Public Comment

NOTE: The following CC Note No. 381 appeared in the First Draft Report on First Revision No. 9220.

CMP 15 should consider whether it would be more appropriate to refer the user to the installation requirements in 517.61 through 517.65 as opposed to pointing the user to Part IV, which this section is part of.

Related Item

- First Revision No. 9220

Submitter Information Verification

Submitter Full Name: CC Notes

Organization: NEC Correlating Committee

Street Address:

City:

State:

Zip:

Submittal Date: Fri Aug 02 11:06:19 EDT 2024

Committee: NEC-P15



Correlating Committee Note No. 381-NFPA 70-2024 [Section No. 517.60]

Submitter Information Verification

Committee: NEC-AAC

Submittal Date: Fri May 10 10:44:14 EDT 2024

Committee Statement

Committee Statement: CMP 15 should consider whether it would be more appropriate to refer the user to the installation requirements in 517.61 through 517.65 as opposed to pointing the user to Part IV, which this section is part of.

First Revision No. 9220-NFPA 70-2024 [Part IV.]

Ballot Results

✓ **This item has passed ballot**

12 Eligible Voters

1 Not Returned

11 Affirmative All

0 Affirmative with Comments

0 Negative with Comments

0 Abstention

Not Returned

McDaniel, Roger D.

Affirmative All

Ayer, Lawrence S.

Bowmer, Trevor N.

Hickman, Palmer L.

Holub, Richard A.

Jackson, Peter D.

Kendall, David H.

Manche, Alan

Osborne, Robert D.

Porter, Christine T.

Schultheis, Timothy James

Williams, David A.



Public Comment No. 681-NFPA 70-2024 [Section No. 517.61]

517.61 Anesthetizing Location Classification.

Anesthetizing location classifications shall comply with 517.61(A) and 517.61(B).

Informational Note: See 517.20 if either of the anesthetizing locations in 517.61(A) or 517.61(B) is designated a wet procedure location.

(A) Hazardous (Classified) Location.

(1) Use Location.

In a location where flammable anesthetics are employed, the entire area shall be considered to be a Class I, Division 1 location that extends upward to a level 1.52 m (5 ft) above the floor.

Informational Note: The remaining volume up to the structural ceiling is considered to be above a hazardous (classified) location.

(2) Storage Location.

Any room or location in which flammable anesthetics or volatile flammable disinfecting agents are stored shall be considered to be a Class I, Division 1 location from floor to ceiling.

(B) Unclassified Location.

Any inhalation anesthetizing location designated for the exclusive use of nonflammable anesthetizing agents shall be considered to be an unclassified location.

Additional Proposed Changes

<u>File Name</u>	<u>Description</u>	<u>Approved</u>
CN_382.pdf		

Statement of Problem and Substantiation for Public Comment

NOTE: The following CC Note No. 382 appeared in the First Draft Report on First Revision No. 9222.

This first revision and Sections 517.61 through 517.65 shall be referred to CMP14 for comment. The current requirements provide Class/Division references in Chapter 5, but not the equivalent Zone references.

Related Item

- First Revision No. 9222

Submitter Information Verification

Submitter Full Name: CC Notes

Organization: NEC Correlating Committee

Street Address:

City:

State:

Zip:

Submittal Date: Fri Aug 02 11:07:32 EDT 2024

Committee: NEC-P15



Correlating Committee Note No. 382-NFPA 70-2024 [Section No. 517.61]

Submitter Information Verification

Committee: NEC-AAC

Submittal Date: Fri May 10 10:47:23 EDT 2024

Committee Statement

Committee Statement: This first revision and Sections 517.61 through 517.65 shall be referred to CMP14 for comment. The current requirements provide Class/Division references in Chapter 5, but not the equivalent Zone references.

First Revision No. 9222-NFPA 70-2024 [Section No. 517.60]

Ballot Results

✓ **This item has passed ballot**

12 Eligible Voters

1 Not Returned

11 Affirmative All

0 Affirmative with Comments

0 Negative with Comments

0 Abstention

Not Returned

McDaniel, Roger D.

Affirmative All

Ayer, Lawrence S.

Bowmer, Trevor N.

Hickman, Palmer L.

Holub, Richard A.

Jackson, Peter D.

Kendall, David H.

Manche, Alan

Osborne, Robert D.

Porter, Christine T.

Schultheis, Timothy James

Williams, David A.



Public Comment No. 682-NFPA 70-2024 [Section No. 517.70]

517.70 Applicability.

Diagnostic imaging and treatment equipment shall be installed in accordance with Article 517, Part V.

Informational Note No. 1: Radiation safety and performance requirements of several classes of X-ray equipment are regulated under Public Law 90-602 and are enforced by the Department of Health and Human Services.

Informational Note No. 2: Information on radiation protection by the National Council on Radiation Protection and Measurements is published as *Reports of the National Council on Radiation Protection and Measurement*.

Informational Note No. 3: Examples of diagnostic imaging equipment can include, but are not limited to, the following:

- (1) General radiographic (X-ray) equipment (mobile and fixed)
- (2) General fluoroscopic equipment (mobile and fixed)
- (3) Interventional equipment (mobile and fixed)
- (4) Bone mineral density equipment
- (5) Dental equipment
- (6) Computerized tomography (CT) equipment
- (7) Positron emission tomography (PET) equipment
- (8) Nuclear medicine equipment
- (9) Mammography equipment
- (10) Magnetic resonance (MR) equipment
- (11) Diagnostic ultrasound equipment
- (12) Electrocardiogram equipment

Informational Note No. 4: Examples of treatment equipment can include, but are not limited to, the following:

- (1) Linear accelerators
- (2) Gamma knife
- (3) Cyber knife
- (4) Proton therapy
- (5) Tomotherapy

Additional Proposed Changes

<u>File Name</u>	<u>Description</u>	<u>Approved</u>
CN_383.pdf		

Statement of Problem and Substantiation for Public Comment

NOTE: The following CC Note No. 383 appeared in the First Draft Report on First Revision No. 9056.

CMP 15 should consider whether it would be more appropriate to refer the user to the installation requirements in 517.71 through 517.78 as opposed to pointing the user to Part V, which this section is part of.

Related Item

- First Revision No. 9056

Submitter Information Verification

Submitter Full Name: CC Notes

Organization: NEC Correlating Committee

Street Address:

City:

State:

Zip:

Submittal Date: Fri Aug 02 11:09:08 EDT 2024

Committee: NEC-P15



Correlating Committee Note No. 383-NFPA 70-2024 [Section No. 517.70]

Submitter Information Verification

Committee: NEC-AAC

Submittal Date: Fri May 10 11:05:44 EDT 2024

Committee Statement

Committee Statement: CMP 15 should consider whether it would be more appropriate to refer the user to the installation requirements in 517.71 through 517.78 as opposed to pointing the user to Part V, which this section is part of.

First Revision No. 9056-NFPA 70-2024 [Section No. 517.70]

Ballot Results

✓ **This item has passed ballot**

12 Eligible Voters

1 Not Returned

11 Affirmative All

0 Affirmative with Comments

0 Negative with Comments

0 Abstention

Not Returned

McDaniel, Roger D.

Affirmative All

Ayer, Lawrence S.

Bowmer, Trevor N.

Hickman, Palmer L.

Holub, Richard A.

Jackson, Peter D.

Kendall, David H.

Manche, Alan

Osborne, Robert D.

Porter, Christine T.

Schultheis, Timothy James

Williams, David A.



Public Comment No. 670-NFPA 70-2024 [Section No. 517.160(A)(4)]

(4) Isolation Transformers.

An isolation transformer shall not serve more than one operating room except as covered in 517.160(A)(4)(a) and 517.160(A)(4)(b).

Informational Note: For purposes of this section, anesthetic induction rooms are considered part of the operating room or rooms served by the induction rooms.

(a) *Induction Rooms.* Where an induction room serves more than one operating room, the isolated circuits of the induction room shall be permitted to be supplied from the isolation transformer of any one of the operating rooms served by that induction room.

(b) *Higher Voltages.* Isolation transformers shall be permitted to serve single receptacles in several patient areas where the following apply:

- (1) The receptacles are reserved for supplying power to equipment requiring 150 volts or higher, such as portable X-ray units.
- (2) The receptacles and mating plugs are not interchangeable with the receptacles on the local isolated power system.

Additional Proposed Changes

<u>File Name</u>	<u>Description</u>	<u>Approved</u>
CN_371.pdf		

Statement of Problem and Substantiation for Public Comment

NOTE: The following CC Note No. 371 appeared in the First Draft Report on First Revision No. 9224.

CMP 15 should consider using the phrase "150 volts or higher between conductors..." in 4(b)(1) for clarity and consistency in this section where other voltage limitations, such as 600 volts between conductors, is used.

CMP 15 shall also ensure that each part of the rule provides a requirement. Changing the prior language to an informational note because it did not contain a requirement and now does not comply with NEC® Style Manual Section 2.1.10.2 by making an interpretation in the informational note.

Related Item

- First Revision No. 9224

Submitter Information Verification

Submitter Full Name: CC Notes

Organization: NEC Correlating Committee

Street Address:

City:

State:

Zip:

Submittal Date: Fri Aug 02 10:35:24 EDT 2024
Committee: NEC-P15



Correlating Committee Note No. 371-NFPA 70-2024 [Section No. 517.160(A)(4)

]

Submitter Information Verification

Committee: NEC-AAC

Submittal Date: Fri May 10 10:11:50 EDT 2024

Committee Statement

Committee Statement: CMP 15 should consider using the phrase "150 volts or higher between conductors..." in 4(b)(1) for clarity and consistency in this section where other voltage limitations, such as 600 volts between conductors, is used.

CMP 15 shall also ensure that each part of the rule provides a requirement. Changing the prior language to an informational note because it did not contain a requirement and now does not comply with NEC® Style Manual Section 2.1.10.2 by making an interpretation in the informational note.

First Revision No. 9224-NFPA 70-2024 [Section No. 517.160(A)(4)]

Ballot Results

✓ **This item has passed ballot**

12 Eligible Voters

1 Not Returned

11 Affirmative All

0 Affirmative with Comments

0 Negative with Comments

0 Abstention

Not Returned

McDaniel, Roger D.

Affirmative All

Ayer, Lawrence S.

Bowmer, Trevor N.

Hickman, Palmer L.

Holub, Richard A.

Jackson, Peter D.

Kendall, David H.

Manche, Alan

Osborne, Robert D.

Porter, Christine T.

Schultheis, Timothy James

Williams, David A.



Public Comment No. 671-NFPA 70-2024 [Section No. 518.6(B)]

(B) Communications Systems, Signaling Systems, Data Systems, and Fire Alarm Systems.

Fixed wiring methods for specific installations shall be as follows:

- (1) Audio signal processing, amplification, and reproduction equipment — 640.9
- (2) Communications systems — Article 805, Part IV, and Article 840, Part VI
- (3) Class 2 and Class 3 remote control and signaling circuits — Article 725, Part II
- (4) Class 2 circuits that transmit power, data, or both to a powered device

Informational Note: See ANSI/NEMA C137.3-2017, *American National Standard for Lighting Systems — Minimum Requirements for Installation of Energy Efficient Power over Ethernet (PoE) Lighting Systems*, for information on installation of cables for PoE lighting systems. See Article 760, Part III, for information on fire alarm circuits.

Additional Proposed Changes

<u>File Name</u>	<u>Description</u>	<u>Approved</u>
CN_372.pdf		

Statement of Problem and Substantiation for Public Comment

NOTE: The following CC Note No. 372 appeared in the First Draft Report on First Revision No. 9144.

CMP 15 shall consider revising 518.6(B) and 520.5(B) for parallel structure in accordance with NEC® Style Manual Section 3.3.5 as the referenced sections are different. Additionally, neither section includes any references to Article 760, so the panel should confirm if fire alarm systems belongs in this section heading.

Related Item

- First Revision No. 9144

Submitter Information Verification

Submitter Full Name: CC Notes

Organization: NEC Correlating Committee

Street Address:

City:

State:

Zip:

Submittal Date: Fri Aug 02 10:36:42 EDT 2024

Committee: NEC-P15



Correlating Committee Note No. 372-NFPA 70-2024 [Section No. 518.6(B)]

Submitter Information Verification

Committee: NEC-AAC

Submittal Date: Fri May 10 10:13:41 EDT 2024

Committee Statement

Committee Statement: CMP 15 shall consider revising 518.6(B) and 520.5(B) for parallel structure in accordance with NEC® Style Manual Section 3.3.5 as the referenced sections are different. Additionally, neither section includes any references to Article 760, so the panel should confirm if fire alarm systems belongs in this section heading.

First Revision No. 9144-NFPA 70-2024 [Section No. 518.4(B)]

Ballot Results

✓ **This item has passed ballot**

12 Eligible Voters

1 Not Returned

11 Affirmative All

0 Affirmative with Comments

0 Negative with Comments

0 Abstention

Not Returned

McDaniel, Roger D.

Affirmative All

Ayer, Lawrence S.

Bowmer, Trevor N.

Hickman, Palmer L.

Holub, Richard A.

Jackson, Peter D.

Kendall, David H.

Manche, Alan

Osborne, Robert D.

Porter, Christine T.

Schultheis, Timothy James

Williams, David A.



Public Comment No. 852-NFPA 70-2024 [Section No. 520.2]

520.2 Listing Requirements.

The following equipment shall be listed:

- (1) Fixed stage switchboards
- (2) Curtain machines
- (3) Portable stage switchboards
- (4) Single-pole portable cable connectors
- (5) Arc lamps and associated ballasts
- (6) Portable power distribution units
- (7) ~~Trunk cables, breakout assemblies, and multicircuit enclosures~~
- (8)

Statement of Problem and Substantiation for Public Comment

The proposed text of 520.2 (7) does not correlate with the first revision text of 520.68(D)(4), which states:

Trunk cables, breakout assemblies, and multicircuit enclosures shall be listed or approved.

Related Item

- FR9163

Submitter Information Verification

Submitter Full Name: Steven Terry

Organization: Electronic Theatre Controls In

Affiliation: USITT

Street Address:

City:

State:

Zip:

Submittal Date: Tue Aug 06 16:37:57 EDT 2024

Committee: NEC-P15



Public Comment No. 673-NFPA 70-2024 [Section No. 520.5(B)]

(B) Communications Systems, Signaling Systems, Data Systems, and Fire Alarm Systems.

Fixed wiring methods for specific installations shall be as follows:

- (1) Audio signal processing, amplification, and reproduction equipment — 640.9
- (2) Communications systems — Article 800, Parts I and IV; Article 805, Part IV; and Article 840, Part VI
- (3) Class 2 and Class 3 remote control and signaling circuits — Article 725, Part II
- (4) Class 2 circuits that transmit power, data, or both to a powered device

Informational Note: See ANSI/NEMA C137.3-2017, *American National Standard for Lighting Systems — Minimum Requirements for Installation of Energy Efficient Power over Ethernet (PoE) Lighting Systems*, for information on installation of cables for PoE lighting systems. See Article 760, Part III, for information on fire alarm circuits.

Additional Proposed Changes

<u>File Name</u>	<u>Description</u>	<u>Approved</u>
CN_373.pdf		

Statement of Problem and Substantiation for Public Comment

NOTE: The following CC Note No. 373 appeared in the First Draft Report on First Revision No. 9159.

CMP 15 shall consider revising 518.6(B) and 520.5(B) for parallel structure in accordance with NEC® Style Manual Section 3.3.5 as the referenced sections are different. Additionally, neither section includes any references to Article 760, so the panel should confirm if fire alarm systems belongs in this section heading.

Related Item

- First Revision No. 9159

Submitter Information Verification

Submitter Full Name: CC Notes
Organization: NEC Correlating Committee
Street Address:
City:
State:
Zip:
Submittal Date: Fri Aug 02 10:37:56 EDT 2024
Committee: NEC-P15



Correlating Committee Note No. 373-NFPA 70-2024 [Section No. 520.5(B)]

Submitter Information Verification

Committee: NEC-AAC

Submittal Date: Fri May 10 10:15:18 EDT 2024

Committee Statement

Committee Statement: CMP 15 shall consider revising 518.6(B) and 520.5(B) for parallel structure in accordance with NEC® Style Manual Section 3.3.5 as the referenced sections are different. Additionally, neither section includes any references to Article 760, so the panel should confirm if fire alarm systems belongs in this section heading.

First Revision No. 9159-NFPA 70-2024 [Section No. 520.5(B)]

Ballot Results

✓ **This item has passed ballot**

12 Eligible Voters

1 Not Returned

11 Affirmative All

0 Affirmative with Comments

0 Negative with Comments

0 Abstention

Not Returned

McDaniel, Roger D.

Affirmative All

Ayer, Lawrence S.

Bowmer, Trevor N.

Hickman, Palmer L.

Holub, Richard A.

Jackson, Peter D.

Kendall, David H.

Manche, Alan

Osborne, Robert D.

Porter, Christine T.

Schultheis, Timothy James

Williams, David A.



Public Comment No. 677-NFPA 70-2024 [Section No. 520.44(C)(2)]

(2) Cords and Cables Not in Contact with Heat-Producing Equipment.

Listed multiconductor extra-hard usage type cords and cables not in direct contact with equipment containing heat-producing elements shall be permitted to have their ampacity determined by Table 520.44(C)(2)(1). Maximum load current in any conductor with an ampacity determined by Table 520.44(C)(2)(1) shall not exceed the values in Table 520.44(C)(2)(1).

Table 520.44(C)(2)(1) Ampacity of Listed Extra-Hard Usage Cords and Cables with Temperature Ratings of 75°C (167°F) and 90°C (194°F) [Based on Ambient Temperature of 30°C (86°F)]

Size (AWG)	Temperature Rating of Cords and Cables		Maximum Rating of Overcurrent Device
	75°C	90°C	
	(167°F)	(194°F)	
14	24	28	15
12	32	35	20
10	41	47	25
8	57	65	35
6	77	87	45
4	101	114	60
2	133	152	80

Note: Ampacity shown shall be the ampacity for multiconductor cords and cables where only three copper conductors are current-carrying in accordance with 400.5. If the number of current-carrying conductors in a cord or cable exceeds three and the load diversity is 50 percent or less, the ampacity of each conductor shall be reduced as shown in Table 520.44(C)(2)(2).

Table 520.44(C)(2)(2) Ampacity Adjustment Factors for More Than Three Current-Carrying Conductors in a Cord or Cable Where Load Diversity Is 50 Percent or Less

Number of Conductors	Percent of Ampacity Value in Table 520.44(C)(2)(a)
4–6	80
7–24	70
25–42	60
43 and above	50

Note: Ultimate insulation temperature. In no case shall conductors be associated together in such a way with respect to the kind of circuit, the wiring method used, or the number of conductors such that the temperature limit of the conductors is exceeded.

In a 3-wire circuit consisting of two-phase conductors and the neutral conductor of a 4-wire, 3-phase, wye-connected system, the neutral conductor carries approximately the same current as the line-to-neutral currents of the other conductors and shall be counted as a current-carrying conductor.

On a 4-wire, 3-phase wye circuit where the major portion of the load consists of nonlinear loads and there are harmonic currents in the neutral conductor, the neutral conductor shall be considered a current-carrying conductor.

Informational Note No. 1: A neutral conductor that carries only the unbalanced current from other conductors of the same circuit need not be considered a current-carrying conductor.

Informational Note No. 2: For the purposes of Table 520.44(C)(2)(1), load diversity is the percentage of the total current of all simultaneously energized circuits fed by the cable to the sum of the ampacities of all pairs of circuit conductors in that cable.

Additional Proposed Changes

<u>File Name</u>	<u>Description</u>	<u>Approved</u>
CN_378.pdf		

Statement of Problem and Substantiation for Public Comment

NOTE: The following CC Note No. 378 appeared in the First Draft Report on First Revision No. 9280.

CMP 15 should consider whether Informational Note No. 1 needs to be written as an exception to the rule for enforceability. The panel shall ensure that each part of the rule provides a requirement. Changing the prior language to an informational note because it did not contain a requirement is now not in compliance with NEC® Style Manual Section 2.1.10.1 by making an interpretation in the informational note. In addition, the panel shall consider whether Informational Note No. 2 complies with NEC® Style Manual Section 2.1.10.1 relative to not making a recommendation in an informational note.

Related Item

- First Revision No. 9280

Submitter Information Verification

Submitter Full Name: CC Notes

Organization: NEC Correlating Committee

Street Address:

City:

State:

Zip:

Submittal Date: Fri Aug 02 10:57:19 EDT 2024

Committee: NEC-P15



Correlating Committee Note No. 378-NFPA 70-2024 [Section No. 520.44(C)(2)]

Submitter Information Verification

Committee: NEC-AAC

Submittal Date: Fri May 10 10:38:15 EDT 2024

Committee Statement

Committee Statement: CMP 15 should consider whether Informational Note No. 1 needs to be written as an exception to the rule for enforceability. The panel shall ensure that each part of the rule provides a requirement. Changing the prior language to an informational note because it did not contain a requirement is now not in compliance with NEC® Style Manual Section 2.1.10.1 by making an interpretation in the informational note. In addition, the panel shall consider whether Informational Note No. 2 complies with NEC® Style Manual Section 2.1.10.1 relative to not making a recommendation in an informational note.

First Revision No. 9280-NFPA 70-2024 [Section No. 520.44(C)(2)]

Ballot Results

✓ **This item has passed ballot**

12 Eligible Voters

1 Not Returned

11 Affirmative All

0 Affirmative with Comments

0 Negative with Comments

0 Abstention

Not Returned

McDaniel, Roger D.

Affirmative All

Ayer, Lawrence S.

Bowmer, Trevor N.

Hickman, Palmer L.

Holub, Richard A.

Jackson, Peter D.

Kendall, David H.

Manche, Alan

Osborne, Robert D.

Porter, Christine T.

Schultheis, Timothy James



Public Comment No. 678-NFPA 70-2024 [Section No. 520.68(D)]

(D) Special-Purpose Multicircuit Cable Systems.

Special-purpose multicircuit cable systems shall comply with the following requirements:

- (1) Branch circuits shall be rated at not more than 20 amperes and not more than 150 volts to ground.
- (2) Trunk cable types shall be extra-hard usage (hard service) or hard usage (junior hard service).
- (3) The ampacity of trunk cables shall be determined in accordance with Table 520.44(C)(2)(1).
- (4) Trunk cables, breakout assemblies, and multicircuit enclosures shall be listed or approved.
- (5) Section 406.12(F) shall not apply to multicircuit, multipole plugs or receptacles that are part of a special-purpose multicircuit cable system.
- (6) When deployed, all multicircuit, multipole connectors shall be clearly marked to uniquely identify the pinout configuration type of the connector and the voltage of the branch circuits serviced by the connector.
- (7) Only qualified persons shall deploy and operate special-purpose multicircuit cable systems.

Informational Note: See ESTA E1.80-202X for information on pinout configuration types.

Additional Proposed Changes

<u>File Name</u>	<u>Description</u>	<u>Approved</u>
CN_379.pdf		

Statement of Problem and Substantiation for Public Comment

NOTE: The following CC Note No. 379 appeared in the First Draft Report on First Revision No. 9163.

CMP 15 shall reconsider FR-9163, specifically in regard to 520.68(D)(4) and the action in FR-9149 (520.2(7)) as these two actions do not correlate. In addition, the panel shall consider whether the referenced standard in the informational note has been published.

A reference cannot be made if the document is not published.

Related Item

- First Revision No. 9163

Submitter Information Verification

Submitter Full Name: CC Notes

Organization: NEC Correlating Committee

Street Address:

City:

State:

Zip:

Submittal Date: Fri Aug 02 10:58:38 EDT 2024

Committee:

NEC-P15



Correlating Committee Note No. 379-NFPA 70-2024 [Section No. 520.68(D)]

Submitter Information Verification

Committee: NEC-AAC

Submittal Date: Fri May 10 10:40:30 EDT 2024

Committee Statement

Committee Statement: CMP 15 shall reconsider FR-9163, specifically in regard to 520.68(D)(4) and the action in FR-9149 (520.2(7)) as these two actions do not correlate. In addition, the panel shall consider whether the referenced standard in the informational note has been published. A reference cannot be made if the document is not published.

First Revision No. 9163-NFPA 70-2024 [Section No. 520.68(D)]

Ballot Results

✓ **This item has passed ballot**

12 Eligible Voters

1 Not Returned

11 Affirmative All

0 Affirmative with Comments

0 Negative with Comments

0 Abstention

Not Returned

McDaniel, Roger D.

Affirmative All

Ayer, Lawrence S.

Bowmer, Trevor N.

Hickman, Palmer L.

Holub, Richard A.

Jackson, Peter D.

Kendall, David H.

Manche, Alan

Osborne, Robert D.

Porter, Christine T.

Schultheis, Timothy James

Williams, David A.



Public Comment No. 789-NFPA 70-2024 [Section No. 525.2]

525.2 Listing Requirements:

~~Egress luminaires shall be listed.~~

Statement of Problem and Substantiation for Public Comment

All luminaires have to be listed. See 410.6 and 90.3 of the NEC, as well as 4.1.1 of the NEC Style Manual.

Related Item

- FR 9205

Submitter Information Verification

Submitter Full Name: Ryan Jackson

Organization: Self-employed

Street Address:

City:

State:

Zip:

Submittal Date: Mon Aug 05 12:06:36 EDT 2024

Committee: NEC-P15



Public Comment No. 790-NFPA 70-2024 [Section No. 525.11]

~~525.11~~ Generators:

~~Generators shall comply with 525.11(A) and 525.11(B) :~~

~~(A) Portable, Vehicle-Mounted and Trailer-Mounted:~~

~~Portable, vehicle-mounted and trailer-mounted generators shall comply with 250.34 :~~

~~(B) Rated Less than 15kW:~~

~~Portable generators less than 15 KW shall comply with 445.20 :~~

Statement of Problem and Substantiation for Public Comment

This is already required by 90.3. See 4.1.1 of the NEC Style Manual.

Related Item

- FR 9205

Submitter Information Verification

Submitter Full Name: Ryan Jackson

Organization: Self-employed

Street Address:

City:

State:

Zip:

Submittal Date: Mon Aug 05 12:10:35 EDT 2024

Committee: NEC-P15



Public Comment No. 1323-NFPA 70-2024 [Section No. 525.31]

525.31 Equipment Grounding.

The equipment grounding conductor shall be connected to the system grounded conductor at the service disconnecting means or, in the case of a separately derived system such as a generator, at the generator or first disconnecting means supplied by the generator.

Exception: - Portable generator - used - in accordance with 445.20(A) Exception

Statement of Problem and Substantiation for Public Comment

This comment is being submitted on behalf of the Minnesota Department of Labor and Industry. Currently, the Department's inspection staff includes 14-office/field staff, 50-state field inspectors, 4-virtual inspectors and 22 plus contract electrical inspectors that complete over 170,000 electrical inspections annually.

Please continue with the proposed changes to the article; however, please revisit the proposed change submitted for 525.31. Many events use small inverter generators which cannot be bonded and they are considered a separately derived system. Please consider the exception that was initially proposed with the Article 525 rewrite to help the AHJ in allowing a very common installation where, technically, there is no way possible to meet the NEC. Again, we are not suggesting all generators, only the generators mentioned the exception in 445.20.

Related Item

- Resolution: FR-9205-NFPA 70-2024

Submitter Information Verification

Submitter Full Name: Dean Hunter

Organization: Minnesota Department of Labor

Street Address:

City:

State:

Zip:

Submittal Date: Tue Aug 20 15:40:16 EDT 2024

Committee: NEC-P15



Public Comment No. 683-NFPA 70-2024 [Section No. 530.4]

530.4 Restricted Public Access.

(A) Studios.

The electrical equipment covered in this article shall be used in motion picture or television studios with restricted public access.

(B) Remote Locations.

Where the equipment is deployed on remote locations, restricted public access shall be provided in the form of physical barriers or other access control measures.

Additional Proposed Changes

<u>File Name</u>	<u>Description</u>	<u>Approved</u>
CN_385.pdf		

Statement of Problem and Substantiation for Public Comment

NOTE: The following CC Note No. 385 appeared in the First Draft Report on First Revision No. 9189.

CMP 15 should consider changing “qualified personnel” in the section heading and “personnel” in the charging language to “qualified persons” as “qualified persons” is the defined term in Article 100.

Related Item

- First Revision No. 9189

Submitter Information Verification

Submitter Full Name: CC Notes

Organization: NEC Correlating Committee

Street Address:

City:

State:

Zip:

Submittal Date: Fri Aug 02 11:10:35 EDT 2024

Committee: NEC-P15



Correlating Committee Note No. 385-NFPA 70-2024 [Section No. 530.4]

Submitter Information Verification

Committee: NEC-AAC

Submittal Date: Fri May 10 11:16:37 EDT 2024

Committee Statement

Committee Statement: CMP 15 should consider changing “qualified personnel” in the section heading and “personnel” in the charging language to “qualified persons” as “qualified persons” is the defined term in Article 100.

First Revision No. 9189-NFPA 70-2024 [Section No. 530.4]

Ballot Results

✓ **This item has passed ballot**

12 Eligible Voters

1 Not Returned

10 Affirmative All

1 Affirmative with Comments

0 Negative with Comments

0 Abstention

Not Returned

McDaniel, Roger D.

Affirmative All

Ayer, Lawrence S.

Hickman, Palmer L.

Holub, Richard A.

Jackson, Peter D.

Kendall, David H.

Manche, Alan

Osborne, Robert D.

Porter, Christine T.

Schultheis, Timothy James

Williams, David A.

Affirmative with Comment

Bowmer, Trevor N.

I agree with replacing the term "personnel" but suggest the CMP should consider a more general term "worker" as a replacement term.



Public Comment No. 684-NFPA 70-2024 [Section No. 530.21(B)]

(B) Outdoor Use.

Portable stage and studio equipment and portable power distribution equipment not identified for outdoor use shall be permitted to be deployed outdoors if the equipment is supervised by qualified personnel while energized and barriered from the general public.

Informational Note No. 1: See ANSI/ESTA E1.58-2017 (R2022), *Electrical Safety Standard for Portable Stage and Studio Equipment Used Outdoors*, for information on the use of portable stage and studio equipment outdoors.

Informational Note No. 2: See ANSI/ESTA E1.19-2021, *Recommended Practice for the Use of Class A Ground-Fault Circuit Interrupters (GFCIs) Intended for Personnel Protection in the Entertainment Industry*, for guidance on the use of GFCIs in wet locations.

Additional Proposed Changes

<u>File Name</u>	<u>Description</u>	<u>Approved</u>
CN_386.pdf		

Statement of Problem and Substantiation for Public Comment

NOTE: The following CC Note No. 386 appeared in the First Draft Report on First Revision No. 9185.

CMP 15 should consider changing “qualified personnel” in the requirement to “qualified persons” as that is the defined term in Article 100.

Related Item

- First Revision No. 9185

Submitter Information Verification

Submitter Full Name: CC Notes

Organization: NEC Correlating Committee

Street Address:

City:

State:

Zip:

Submittal Date: Fri Aug 02 11:11:48 EDT 2024

Committee: NEC-P15



Correlating Committee Note No. 386-NFPA 70-2024 [Section No. 530.21(B)]

Submitter Information Verification

Committee: NEC-AAC

Submittal Date: Fri May 10 11:17:57 EDT 2024

Committee Statement

Committee Statement: CMP 15 should consider changing “qualified personnel” in the requirement to “qualified persons” as that is the defined term in Article 100.

First Revision No. 9185-NFPA 70-2024 [Section No. 530.21(B)]

Ballot Results

✔ **This item has passed ballot**

12 Eligible Voters

1 Not Returned

10 Affirmative All

1 Affirmative with Comments

0 Negative with Comments

0 Abstention

Not Returned

McDaniel, Roger D.

Affirmative All

Ayer, Lawrence S.

Hickman, Palmer L.

Holub, Richard A.

Jackson, Peter D.

Kendall, David H.

Manche, Alan

Osborne, Robert D.

Porter, Christine T.

Schultheis, Timothy James

Williams, David A.

Affirmative with Comment

Bowmer, Trevor N.

I agree with replacing the term "personnel" but suggest the CMP should consider a more general term "worker" as a replacement term.



Public Comment No. 191-NFPA 70-2024 [Section No. 530.72]

530.72 Over 1000 Volts, Nominal.

Wiring and equipment of portable substations rated over 1000 volts, nominal, shall comply with the requirements of Article ~~490~~ 495, Part IV.

Statement of Problem and Substantiation for Public Comment

Revised reference to the correct revised article number 495 (NEC-2023) from the previous (NEC-2020) article number of 490.

Related Item

- Public Input No. 2694-NFPA 70-2023

Submitter Information Verification

Submitter Full Name: Kevin Rogers

Organization: Engineering Professional Dev

Street Address:

City:

State:

Zip:

Submittal Date: Tue Jul 23 20:25:39 EDT 2024

Committee: NEC-P15



Public Comment No. 685-NFPA 70-2024 [Section No. 530.72]

530.72 Over 1000 Volts, Nominal.

Wiring and equipment of portable substations rated over 1000 volts, nominal, shall comply with the requirements of Article 490, Part IV.

Additional Proposed Changes

<u>File Name</u>	<u>Description</u>	<u>Approved</u>
CN_388.pdf		

Statement of Problem and Substantiation for Public Comment

NOTE: The following CC Note No. 388 appeared in the First Draft Report on First Revision No. 9195.

The current reference to Article 490, Part IV, does not correlate with the 2023 update which moved this information to Article 495. CMP 15 shall reconsider this FR and correlate the referencer accordingly. In addition, the panel should clarify the limits in 530.71 in accordance with PI 2428 in relation to this reference.

Related Item

- First Revision No. 9195

Submitter Information Verification

Submitter Full Name: CC Notes

Organization: NEC Correlating Committee

Street Address:

City:

State:

Zip:

Submittal Date: Fri Aug 02 11:13:05 EDT 2024

Committee: NEC-P15



Correlating Committee Note No. 388-NFPA 70-2024 [Section No. 530.72]

Submitter Information Verification

Committee: NEC-AAC

Submittal Date: Fri May 10 11:27:56 EDT 2024

Committee Statement

Committee Statement: The current reference to Article 490, Part IV, does not correlate with the 2023 update which moved this information to Article 495. CMP 15 shall reconsider this FR and correlate the referencer accordingly. In addition, the panel should clarify the limits in 530.71 in accordance with PI 2428 in relation to this reference.

First Revision No. 9195-NFPA 70-2024 [Section No. 530.72]

Ballot Results

✓ **This item has passed ballot**

12 Eligible Voters

1 Not Returned

11 Affirmative All

0 Affirmative with Comments

0 Negative with Comments

0 Abstention

Not Returned

McDaniel, Roger D.

Affirmative All

Ayer, Lawrence S.

Bowmer, Trevor N.

Hickman, Palmer L.

Holub, Richard A.

Jackson, Peter D.

Kendall, David H.

Manche, Alan

Osborne, Robert D.

Porter, Christine T.

Schultheis, Timothy James

Williams, David A.



Public Comment No. 1270-NFPA 70-2024 [New Part after I.]

517.2 Electrical Service

(A) In addition to off-site utility provided electrical service, the following sources may be considered for service to the entire electrical load for the facility based on reliability:

- (1) Generating Units
- (2) Fuel Cell Systems
- (3) Energy Storage Systems
- (4) Health Care Microgrid

(B) Capacity of Systems. The systems shall have the capacity and rating to meet the maximum actual demand to be produced by the connected load on the system. Demand calculations for sizing of the systems shall be based on any of the following:

- (1) Prudent demand factors and historic data.
- (2) Connected load.
- (3) Feeder calculations.
- (4) Any combination of the above.

Statement of Problem and Substantiation for Public Comment

The CMP rejected a number of PIs that attempted to define the sources that must be provided to serve the entire facility electrical load. This PI is an almost verbatim quote from one of the people who led the charge for rejection. The essence of that argument was that nothing was as reliable as an off-site utility service. I have therefore adopted all of that language, in order to advance this issue.

With the advent of the language we have elsewhere in the code about service to essential system loads (e.g. two independent sources or sets of sources), and the fact that either of them might be operating at all times, rendering the OTHER the “backup” source, it is very important that we define what happens with sources on both sides of the transfer switch in terms of sources.

Also, NFPA 99 just adopted very similar language, and we need to correlate the two documents.

Finally, this PI includes needed clarity on how to size the sources on the “normal” side of the transfer switch. The CMP rejected this language during the PI stage, due to the fact that these calculations are covered in other sections of the code. This is not a good argument. In many places, 517 takes exception to what is in other sections due to the unique needs of healthcare. Healthcare, we know, is the largest consumer of energy of any building type other than restaurants (see EPA). Every electrical engineer knows that the calculation procedures in other parts of the code create oversized electrical systems. Every electrical engineer knows that the utility will not provide the same amount of power that the designer is forced to provide (often by an order of magnitude). And, the move to electrification is happening across the country (see <https://www.spglobal.com/marketintelligence/en/news-insights/latest-news-headlines/gas-ban-monitor-building-electrification-evolves-as-19-states-prohibit-bans-65518738>). the committee said this was only a California problem, but it is not. As more jurisdictions pass requirements for all-electric buildings, the gap between what is calculated and what is really needed can only grow.

NOT adding this language will force every hospital in the country to buy too much capacity that they will never use. It wastes resources, and drives upon the cost of healthcare.

The code already permits exactly this methodology to size the sources on one side of the system. There is no rational reason for NOT allowing it on the other side.

It is time to get this done. Thank you.

Related Item

- 2515

Submitter Information Verification

Submitter Full Name: Walt Veernon

Organization: Mazzetti

Affiliation: None

Street Address:

City:

State:

Zip:

Submittal Date: Mon Aug 19 13:39:50 EDT 2024

Committee: NEC-P15



Public Comment No. 1775-NFPA 70-2024 [Part V.]

Part V. Diagnostic Imaging and Treatment Equipment

PART VI. Control -Emergency Lighting Circuits

517.170 Switch Location.

All manual switches for controlling emergency circuits shall be in locations convenient to authorized persons responsible for their actuation.

Exception: Where multiple switches are provided, one such switch shall be permitted in such locations where arranged so that it can only energize the circuit but cannot de-energize the circuit.

517.171 Exterior Lights.

Those lights on the exterior of a building that are not required for illumination when there is sufficient daylight shall be permitted to be controlled by an automatic light-actuated device.

517.172 Dimmer and Relay Systems.

A dimmer or relay system containing more than one dimmer or relay and listed for use in emergency systems shall be permitted to be used as a control device for energizing emergency lighting circuits. Upon failure of normal power, the dimmer or relay system shall be permitted to selectively energize only those branch circuits required to provide minimum emergency illumination using a control bypass function. Where the dimmer or relay system is fed by a normal/emergency power source from an upstream transfer switch, normal power sensing for this function shall be permitted to be from a normal-only power source upstream of the transfer switch. All branch circuits supplied by the dimmer or relay system cabinet shall comply with the wiring methods of Part II of Article 517.

517.173 Directly Controlled Emergency Luminaires.

Where emergency illumination is provided by one or more directly controlled emergency luminaires that, upon loss of normal power, respond to an external control input to establish the required emergency illumination level, such directly controlled emergency luminaires shall be listed for use in emergency systems. Luminaires that are energized to the required emergency illumination level by disconnection of their control input by a listed emergency lighting control device shall not be required to be listed for use in emergency systems.

517.174 Branch Circuit Emergency Lighting Transfer Switch.

Emergency lighting loads supplied by branch circuits rated at not greater than 20 amperes shall be permitted to be transferred from the normal branch circuit to an emergency branch circuit using a listed branch circuit emergency lighting transfer switch. The listed branch circuit emergency lighting transfer switches shall not be required to be mechanically held.

517.175 Automatic Load Control Relay.

If an emergency lighting load is automatically energized upon loss of the normal supply, a listed automatic load control relay shall be permitted to energize the load. The load control relay shall not be used as transfer equipment.

517.176 Class 2 Powered Emergency Lighting Systems.

Devices that combine control signals with Class 2 emergency power on a single circuit shall be listed as emergency lighting control devices.

Informational Note: An example of a device combining control signals with Class 2 emergency power sources is a Power over Ethernet (PoE) switch.

FR-8982 proposes to remove the requirement to comply with Article 700, which would result in the loss of requirement for the control of emergency lighting circuits. This P.C. propose to add this requirement into 517. the text proposed to be added here is copied from Article 700 Part V with minor revisions to remove references to article 700.

Related Item

- FR-8982

Submitter Information Verification

Submitter Full Name: Jamie Schnick
Organization: HCAI/OSHPD
Affiliation: CA Department of Health Care Access and Information/Office of Hospital Planning and Development
Street Address:
City:
State:
Zip:
Submittal Date: Tue Aug 27 10:31:17 EDT 2024
Committee: NEC-P15



Public Comment No. 708-NFPA 70-2024 [Section No. 120.110]

120.110 Receptacle Loads.

Receptacle loads calculated in accordance with 120.14(H) and 120.14(I) and supplied by branch circuits not exceeding 150 volts to ground shall be permitted to be subjected to the demand factors provided in Table 120.110 for health care facilities.

Informational Note No. 1: See Article 100 for the definitions of patient care space categories.

Informational Note No. 2: See 120.14(I) for the calculation of receptacle outlet loads.

Table 120.110 Demand Factors for Receptacles Supplied by General-Purpose Branch Circuits in Health Care Facilities

<u>Portion of Receptacle Load to Which Demand Factor Applies (Volt-Amperes)</u>	<u>Demand Factor (%)</u>
First 10,000 or less	100
Remainder over 10,000	20

Additional Proposed Changes

<u>File Name</u>	<u>Description</u>	<u>Approved</u>
CN_208.pdf		✓

Statement of Problem and Substantiation for Public Comment

NOTE: The following CC Note No. 208 appeared in the First Draft Report on First Revision No. 9203.

The chairs of CMP 2 and CMP 15 are directed to form a task group to review general purpose receptacle demand factors. CMP 2 has purview for general purpose receptacle demand in all occupancies. Any data supporting proposed revisions to receptacle demand factors must be provided for public review.

The Correlating Committee directs the panel to consider Informational Note No.1 for compliance with 2.1.10.1 of the NEC® Style Manual. The panel should confirm the need for Informational Note No. 1, given this first revision which eliminates the Category 1, 2, 3, or 4 restrictions to the use of this demand factor table and instead applies this table to all health care facilities.

Related Item

- First Revision No. 9203

Submitter Information Verification

Submitter Full Name: CC Notes

Organization: NEC Correlating Committee

Street Address:

City:

State:

Zip:

Submittal Date: Fri Aug 02 14:08:38 EDT 2024

Committee: NEC-P15

Copyright Assignment

I, CC Notes, hereby irrevocably grant and assign to the National Fire Protection Association (NFPA) all and full rights in copyright in this Public Comment (including both the Proposed Change and the Statement of Problem and Substantiation). I understand and intend that I acquire no rights, including rights as a joint author, in any publication of the NFPA in which this Public Comment in this or another similar or derivative form is used. I hereby warrant that I am the author of this Public Comment and that I have full power and authority to enter into this copyright assignment.

By checking this box I affirm that I am CC Notes, and I agree to be legally bound by the above Copyright Assignment and the terms and conditions contained therein. I understand and intend that, by checking this box, I am creating an electronic signature that will, upon my submission of this form, have the same legal force and effect as a handwritten signature



Correlating Committee Note No. 208-NFPA 70-2024 [Section No. 220.110]

Submitter Information Verification

Committee: NEC-AAC

Submittal Date: Thu May 09 11:35:55 EDT 2024

Committee Statement

Committee Statement: The chairs of CMP 2 and CMP 15 are directed to form a task group to review general purpose receptacle demand factors. CMP 2 has purview for general purpose receptacle demand in all occupancies. Any data supporting proposed revisions to receptacle demand factors must be provided for public review.

The Correlating Committee directs the panel to consider Informational Note No.1 for compliance with 2.1.10.1 of the NEC® Style Manual. The panel should confirm the need for Informational Note No. 1, given this first revision which eliminates the Category 1, 2, 3, or 4 restrictions to the use of this demand factor table and instead applies this table to all health care facilities.

[First Revision No. 9203-NFPA 70-2024 \[Section No. 220.110\]](#)

Ballot Results

✓ **This item has passed ballot**

12 Eligible Voters

1 Not Returned

11 Affirmative All

0 Affirmative with Comments

0 Negative with Comments

0 Abstention

Not Returned

McDaniel, Roger D.

Affirmative All

Ayer, Lawrence S.

Bowmer, Trevor N.

Hickman, Palmer L.

Holub, Richard A.

Jackson, Peter D.

Kendall, David H.

Manche, Alan

Osborne, Robert D.

Porter, Christine T.

Schultheis, Timothy James

Williams, David A.



Public Comment No. 709-NFPA 70-2024 [Section No. 120.111]

120.111 Specific Appliance Loads.

Receptacle loads calculated in accordance with 120.14(A) and supplied by branch circuits not exceeding 150 volts to ground shall be permitted to be subjected to the demand factors provided in Table 120.111 for health care facilities.

Table 120.111 Specific Appliance Demand Factor for Health Care Facilities

<u>Number of Circuits</u>	<u>Demand Factor (%)</u>
0–10	100
11 or more	30

Additional Proposed Changes

<u>File Name</u>	<u>Description</u>	<u>Approved</u>
CN_209.pdf		✓

Statement of Problem and Substantiation for Public Comment

NOTE: The following CC Note No. 209 appeared in the First Draft Report on First Revision No. 9204.

The chairs of CMP 2 and CMP 15 are directed to form a task group to review the load calculations for specific appliance loads. CMP 2 has purview for specific appliance demand in all occupancies. Any data supporting proposed revisions to receptacle demand factors must be provided for public review.

Related Item

- First Revision No. 9204

Submitter Information Verification

Submitter Full Name: CC Notes
Organization: NEC Correlating Committee
Street Address:
City:
State:
Zip:
Submission Date: Fri Aug 02 14:09:56 EDT 2024
Committee: NEC-P15

Copyright Assignment

I, CC Notes, hereby irrevocably grant and assign to the National Fire Protection Association (NFPA) all and full rights in copyright in this Public Comment (including both the Proposed Change and the Statement of Problem and Substantiation). I understand and intend that I acquire no rights, including rights as a joint author, in any publication of the NFPA in which this Public Comment in this or another similar or derivative form is used. I hereby warrant that I am the author of this Public Comment and that I have full power and authority to enter into this copyright assignment.

By checking this box I affirm that I am CC Notes, and I agree to be legally bound by the above Copyright Assignment and the terms and conditions contained therein. I understand and intend that, by checking this box, I am creating an electronic signature that will, upon my submission of this form, have the same legal force and effect as a handwritten signature



Correlating Committee Note No. 209-NFPA 70-2024 [Section No. 220.111]

Submitter Information Verification

Committee: NEC-AAC

Submittal Date: Thu May 09 11:39:10 EDT 2024

Committee Statement

Committee Statement: The chairs of CMP 2 and CMP 15 are directed to form a task group to review the load calculations for specific appliance loads. CMP 2 has purview for specific appliance demand in all occupancies. Any data supporting proposed revisions to receptacle demand factors must be provided for public review.

First Revision No. 9204-NFPA 70-2024 [New Section after 220.110]

Ballot Results

✓ **This item has passed ballot**

12 Eligible Voters

1 Not Returned

11 Affirmative All

0 Affirmative with Comments

0 Negative with Comments

0 Abstention

Not Returned

McDaniel, Roger D.

Affirmative All

Ayer, Lawrence S.

Bowmer, Trevor N.

Hickman, Palmer L.

Holub, Richard A.

Jackson, Peter D.

Kendall, David H.

Manche, Alan

Osborne, Robert D.

Porter, Christine T.

Schultheis, Timothy James

Williams, David A.



Public Comment No. 327-NFPA 70-2024 [Global Input]

CMP 1 has deleted the definition for “In Sight From”, and the requirements that were part of that definition are now located in 110.29. This global Correlating Committee Note directs all CMP’s to review occurrences of the phrase “in sight from”, “within sight from”, and “within sight” and consider whether references to 110.29 or 110.39 should be included.

Additional Proposed Changes

<u>File Name</u>	<u>Description</u>	<u>Approved</u>
CN_26.pdf	NEC_CN26	✓

Statement of Problem and Substantiation for Public Comment

NOTE: The following CC Note No. 26 appeared in the First Draft Report on First Revision No. 9187.

CMP 1 has deleted the definition for “In Sight From”, and the requirements that were part of that definition are now located in 110.29. This global Correlating Committee Note directs all CMP’s to review occurrences of the phrase “in sight from”, “within sight from”, and “within sight” and consider whether references to 110.29 or 110.39 should be included.

Related Item

- First Revision No. 9187

Submitter Information Verification

Submitter Full Name: CC Notes

Organization: NEC Correlating Committee

Street Address:

City:

State:

Zip:

Submittal Date: Mon Jul 29 17:05:29 EDT 2024

Committee: NEC-P01

Copyright Assignment

I, CC Notes, hereby irrevocably grant and assign to the National Fire Protection Association (NFPA) all and full rights in copyright in this Public Comment (including both the Proposed Change and the Statement of Problem and Substantiation). I understand and intend that I acquire no rights, including rights as a joint author, in any publication of the NFPA in which this Public Comment in this or another similar or derivative form is used. I hereby warrant that I am the author of this Public Comment and that I have full power and authority to enter into this copyright assignment.

By checking this box I affirm that I am CC Notes, and I agree to be legally bound by the above Copyright Assignment and the terms and conditions contained therein. I understand and intend that, by checking this box, I am creating an electronic signature that will, upon my submission of this form, have the same legal force and effect as a handwritten signature



Correlating Committee Note No. 26-NFPA 70-2024 [Global Input]

Submitter Information Verification

Committee: NEC-AAC

Submittal Date: Tue May 07 14:23:07 EDT 2024

Committee Statement and Meeting Notes

Committee Statement: CMP 1 has deleted the definition for “In Sight From”, and the requirements that were part of that definition are now located in 110.29. This global Correlating Committee Note directs all CMP’s to review occurrences of the phrase “in sight from”, “within sight from”, and “within sight” and consider whether references to 110.29 or 110.39 should be included.

First Revision No. 9187-NFPA 70-2024 [Section No. 225.41]

Ballot Results

✔ **This item has passed ballot**

12 Eligible Voters

1 Not Returned

11 Affirmative All

0 Affirmative with Comments

0 Negative with Comments

0 Abstention

Not Returned

McDaniel, Roger D.

Affirmative All

Ayer, Lawrence S.

Bowmer, Trevor N.

Hickman, Palmer L.

Holub, Richard A.

Jackson, Peter D.

Kendall, David H.

Manche, Alan

Osborne, Robert D.

Porter, Christine T.

Schultheis, Timothy James

Williams, David A.



Public Comment No. 443-NFPA 70-2024 [Global Input]

The Correlating Committee directs all Code-Making Panels to verify cross-references to Article 200 are accurate due to the renumbering of the article.

Additional Proposed Changes

<u>File Name</u>	<u>Description</u>	<u>Approved</u>
CN_84.pdf		✓

Statement of Problem and Substantiation for Public Comment

NOTE: The following CC Note No. 84 appeared in the First Draft Report.

The Correlating Committee directs all Code-Making Panels to verify cross-references to Article 200 are accurate due to the renumbering of the article.

Related Item

- Correlating Committee Note No. 84

Submitter Information Verification

Submitter Full Name: CC Notes

Organization: NEC Correlating Committee

Street Address:

City:

State:

Zip:

Submittal Date: Tue Jul 30 17:35:49 EDT 2024

Committee: NEC-P05

Copyright Assignment

I, CC Notes, hereby irrevocably grant and assign to the National Fire Protection Association (NFPA) all and full rights in copyright in this Public Comment (including both the Proposed Change and the Statement of Problem and Substantiation). I understand and intend that I acquire no rights, including rights as a joint author, in any publication of the NFPA in which this Public Comment in this or another similar or derivative form is used. I hereby warrant that I am the author of this Public Comment and that I have full power and authority to enter into this copyright assignment.

By checking this box I affirm that I am CC Notes, and I agree to be legally bound by the above Copyright Assignment and the terms and conditions contained therein. I understand and intend that, by checking this box, I am creating an electronic signature that will, upon my submission of this form, have the same legal force and effect as a handwritten signature



Correlating Committee Note No. 84-NFPA 70-2024 [Global Input]

Submitter Information Verification

Committee: NEC-AAC

Submittal Date: Wed May 08 08:49:53 EDT 2024

Committee Statement

Committee Statement: The Correlating Committee directs all Code-Making Panels to verify cross-references to Article 200 are accurate due to the renumbering of the article.

Ballot Results

✔ **This item has passed ballot**

12 Eligible Voters

1 Not Returned

11 Affirmative All

0 Affirmative with Comments

0 Negative with Comments

0 Abstention

Not Returned

McDaniel, Roger D.

Affirmative All

Ayer, Lawrence S.

Bowmer, Trevor N.

Hickman, Palmer L.

Holub, Richard A.

Jackson, Peter D.

Kendall, David H.

Manche, Alan

Osborne, Robert D.

Porter, Christine T.

Schultheis, Timothy James

Williams, David A.



Public Comment No. 493-NFPA 70-2024 [Global Input]

The Correlating Committee directs CMPs 1, 10, and 15 to consider use of two defined terms in the NEC, “panelboard” and “enclosure” arranged as “panelboard enclosure” which provides a suitable replacement for the current term “enclosed panelboard”. CMP 10 has deleted the term “enclosed panelboard”

Additional Proposed Changes

<u>File Name</u>	<u>Description</u>	<u>Approved</u>
CN_140.pdf		✓

Statement of Problem and Substantiation for Public Comment

NOTE: The following CC Note No. 140 appeared in the First Draft Report on First Revision No. 8903.

The Correlating Committee directs CMPs 1, 10, and 15 to consider use of two defined terms in the NEC, “panelboard” and “enclosure” arranged as “panelboard enclosure” which provides a suitable replacement for the current term “enclosed panelboard”. CMP 10 has deleted the term “enclosed panelboard”

Related Item

- First Revision No. 8903

Submitter Information Verification

Submitter Full Name: CC Notes

Organization: NEC Correlating Committee

Street Address:

City:

State:

Zip:

Submittal Date: Tue Jul 30 20:00:23 EDT 2024

Committee: NEC-P10

Copyright Assignment

I, CC Notes, hereby irrevocably grant and assign to the National Fire Protection Association (NFPA) all and full rights in copyright in this Public Comment (including both the Proposed Change and the Statement of Problem and Substantiation). I understand and intend that I acquire no rights, including rights as a joint author, in any publication of the NFPA in which this Public Comment in this or another similar or derivative form is used. I hereby warrant that I am the author of this Public Comment and that I have full power and authority to enter into this copyright assignment.

By checking this box I affirm that I am CC Notes, and I agree to be legally bound by the above Copyright Assignment and the terms and conditions contained therein. I understand and intend that, by checking this box, I am creating an electronic signature that will, upon my submission of this form, have the same legal force and effect as a handwritten signature



Correlating Committee Note No. 140-NFPA 70-2024 [Global Input]

Submitter Information Verification

Committee: NEC-AAC

Submittal Date: Wed May 08 16:47:26 EDT 2024

Committee Statement and Meeting Notes

Committee Statement: The Correlating Committee directs CMPs 1, 10, and 15 to consider use of two defined terms in the NEC, “panelboard” and “enclosure” arranged as “panelboard enclosure” which provides a suitable replacement for the current term “enclosed panelboard”. CMP 10 has deleted the term “enclosed panelboard”

Committee Notes:

Date Submitted By

May 8, 2024 Sarah Caldwell CMP 1, 10 and 15

First Revision No. 8903-NFPA 70-2024 [Definition: Panelboard, Enclosed. (Enclosed Panelboard)]

Ballot Results

✔ This item has passed ballot

12 Eligible Voters

1 Not Returned

10 Affirmative All

0 Affirmative with Comments

1 Negative with Comments

0 Abstention

Not Returned

McDaniel, Roger D.

Affirmative All

Ayer, Lawrence S.

Bowmer, Trevor N.

Holub, Richard A.

Jackson, Peter D.

Kendall, David H.

Manche, Alan

Osborne, Robert D.

Porter, Christine T.

Schultheis, Timothy James

Williams, David A.

Negative with Comment

Hickman, Palmer L.

For correlation, "enclosed panelboard" continues to be the correct definition and term as added and used in the 2023 NEC.



Public Comment No. 504-NFPA 70-2024 [Global Input]

The Correlating Committee directs the CMPs to review the revision of the title of Article 406 (Wiring Devices) and the new definition for the term "wiring device" in Article 100 for correlation of existing terminology using the newly define term in their articles.

Additional Proposed Changes

<u>File Name</u>	<u>Description</u>	<u>Approved</u>
CN_157.pdf		✓

Statement of Problem and Substantiation for Public Comment

NOTE: The following CC Note No. 157 appeared in the First Draft Report on First Revision No. 7965.

The Correlating Committee directs the CMPs to review the revision of the title of Article 406 (Wiring Devices) and the new definition for the term "wiring device" in Article 100 for correlation of existing terminology using the newly define term in their articles.

Related Item

- First Revision No. 7965

Submitter Information Verification

Submitter Full Name: CC Notes

Organization: NEC Correlating Committee

Street Address:

City:

State:

Zip:

Submittal Date: Tue Jul 30 22:29:14 EDT 2024

Committee: NEC-P18

Copyright Assignment

I, CC Notes, hereby irrevocably grant and assign to the National Fire Protection Association (NFPA) all and full rights in copyright in this Public Comment (including both the Proposed Change and the Statement of Problem and Substantiation). I understand and intend that I acquire no rights, including rights as a joint author, in any publication of the NFPA in which this Public Comment in this or another similar or derivative form is used. I hereby warrant that I am the author of this Public Comment and that I have full power and authority to enter into this copyright assignment.

By checking this box I affirm that I am CC Notes, and I agree to be legally bound by the above Copyright Assignment and the terms and conditions contained therein. I understand and intend that, by checking this box, I am creating an electronic signature that will, upon my submission of this form, have the same legal force and effect as a handwritten signature



Correlating Committee Note No. 157-NFPA 70-2024 [Global Input]

Submitter Information Verification

Committee: NEC-AAC

Submittal Date: Thu May 09 08:59:03 EDT 2024

Committee Statement and Meeting Notes

Committee Statement: The Correlating Committee directs the CMPs to review the revision of the title of Article 406 (Wiring Devices) and the new definition for the term "wiring device" in Article 100 for correlation of existing terminology using the newly define term in their articles.

First Revision No. 7965-NFPA 70-2024 [New Definition after Definition: Wireways, Nonmetallic..(No...)]

Ballot Results

✔ This item has passed ballot

12 Eligible Voters

1 Not Returned

11 Affirmative All

0 Affirmative with Comments

0 Negative with Comments

0 Abstention

Not Returned

McDaniel, Roger D.

Affirmative All

Ayer, Lawrence S.

Bowmer, Trevor N.

Hickman, Palmer L.

Holub, Richard A.

Jackson, Peter D.

Kendall, David H.

Manche, Alan

Osborne, Robert D.

Porter, Christine T.

Schultheis, Timothy James

Williams, David A.



Public Comment No. 505-NFPA 70-2024 [Definitions (100): Equipment, ... to Equipment, ...]

Definitions (100): Equipment, ... to Equipment, ...

Equipment, Portable. (Portable Equipment)

Equipment fed with portable cords or cables intended to be moved from one place to another. (640) (CMP-12)

Equipment, Portable. (Portable Equipment)

Equipment with electrical components suitable to be moved by a single person without mechanical aids. (511) (CMP-14)

Equipment, Portable. (Portable Equipment)

Equipment fed with portable cords or cables intended to be moved from one place to another. (520) (CMP-15)

Equipment, Portable. (Portable Equipment)

Equipment intended to be moved from one place to another. (530) (CMP-15)

Additional Proposed Changes

<u>File Name</u>	<u>Description</u>	<u>Approved</u>
CN_179.pdf		✓

Statement of Problem and Substantiation for Public Comment

NOTE: The following CC Note No. 179 appeared in the First Draft Report.

The CC directs that a task group be formed with members from CMP's 12, 14 and 15 for consideration of creating a single definition for the term "equipment, portable".

Related Item

- Correlating Committee Note No. 179

Submitter Information Verification

Submitter Full Name: CC Notes
Organization: NEC Correlating Committee
Street Address:
City:
State:
Zip:
Submittal Date: Tue Jul 30 22:31:40 EDT 2024
Committee: NEC-P12

Copyright Assignment

I, CC Notes, hereby irrevocably grant and assign to the National Fire Protection Association (NFPA) all and full rights in copyright in this Public Comment (including both the Proposed Change and the Statement of Problem and Substantiation). I understand and intend that I acquire no rights, including rights as a joint author, in any publication of the NFPA in which this Public Comment

in this or another similar or derivative form is used. I hereby warrant that I am the author of this Public Comment and that I have full power and authority to enter into this copyright assignment.

By checking this box I affirm that I am CC Notes, and I agree to be legally bound by the above Copyright Assignment and the terms and conditions contained therein. I understand and intend that, by checking this box, I am creating an electronic signature that will, upon my submission of this form, have the same legal force and effect as a handwritten signature



Correlating Committee Note No. 179-NFPA 70-2024 [Definitions (100):

Equipment, ... to Equipment, ...]

Submitter Information Verification

Committee: NEC-AAC

Submittal Date: Thu May 09 09:43:06 EDT 2024

Committee Statement

Committee Statement: The CC directs that a task group be formed with members from CMP's 12, 14 and 15 for consideration of creating a single definition for the term "equipment, portable".

Ballot Results

✔ This item has passed ballot

12 Eligible Voters

1 Not Returned

11 Affirmative All

0 Affirmative with Comments

0 Negative with Comments

0 Abstention

Not Returned

McDaniel, Roger D.

Affirmative All

Ayer, Lawrence S.

Bowmer, Trevor N.

Hickman, Palmer L.

Holub, Richard A.

Jackson, Peter D.

Kendall, David H.

Manche, Alan

Osborne, Robert D.

Porter, Christine T.

Schultheis, Timothy James

Williams, David A.



Public Comment No. 527-NFPA 70-2024 [Global Input]

The CMPs are directed to review references to Article 220 in the articles under their purview and make necessary revisions based on Article 220 being relocated to Article 120.

Additional Proposed Changes

<u>File Name</u>	<u>Description</u>	<u>Approved</u>
CN_212.pdf		✓

Statement of Problem and Substantiation for Public Comment

NOTE: The following CC Note No. 212 appeared in the First Draft Report.

The CMPs are directed to review references to Article 220 in the articles under their purview and make necessary revisions based on Article 220 being relocated to Article 120.

Related Item

- Correlating Committee Note No. 212

Submitter Information Verification

Submitter Full Name: CC Notes

Organization: NEC Correlating Committee

Street Address:

City:

State:

Zip:

Submittal Date: Tue Jul 30 23:08:41 EDT 2024

Committee: NEC-P02

Copyright Assignment

I, CC Notes, hereby irrevocably grant and assign to the National Fire Protection Association (NFPA) all and full rights in copyright in this Public Comment (including both the Proposed Change and the Statement of Problem and Substantiation). I understand and intend that I acquire no rights, including rights as a joint author, in any publication of the NFPA in which this Public Comment in this or another similar or derivative form is used. I hereby warrant that I am the author of this Public Comment and that I have full power and authority to enter into this copyright assignment.

By checking this box I affirm that I am CC Notes, and I agree to be legally bound by the above Copyright Assignment and the terms and conditions contained therein. I understand and intend that, by checking this box, I am creating an electronic signature that will, upon my submission of this form, have the same legal force and effect as a handwritten signature



Correlating Committee Note No. 212-NFPA 70-2024 [Global Input]

Submitter Information Verification

Committee: NEC-AAC

Submittal Date: Thu May 09 11:53:08 EDT 2024

Committee Statement and Meeting Notes

Committee Statement: The CMPs are directed to review references to Article 220 in the articles under their purview and make necessary revisions based on Article 220 being relocated to Article 120.

Ballot Results

✔ This item has passed ballot

12 Eligible Voters

1 Not Returned

11 Affirmative All

0 Affirmative with Comments

0 Negative with Comments

0 Abstention

Not Returned

McDaniel, Roger D.

Affirmative All

Ayer, Lawrence S.

Bowmer, Trevor N.

Hickman, Palmer L.

Holub, Richard A.

Jackson, Peter D.

Kendall, David H.

Manche, Alan

Osborne, Robert D.

Porter, Christine T.

Schultheis, Timothy James

Williams, David A.



Public Comment No. 542-NFPA 70-2024 [Global Input]

The Correlating Committee directs the CMPs to review all references to requirements in Chapters 7 & 8 for accuracy in light of the relocation of requirements occurring in the First Draft.

Additional Proposed Changes

<u>File Name</u>	<u>Description</u>	<u>Approved</u>
CN_401.pdf		✓

Statement of Problem and Substantiation for Public Comment

NOTE: The following CC Note No. 401 appeared in the First Draft Report.

The Correlating Committee directs the CMPs to review all references to requirements in Chapters 7 & 8 for accuracy in light of the relocation of requirements occurring in the First Draft.

Related Item

- Correlating Committee Note No. 401

Submitter Information Verification

Submitter Full Name: CC Notes
Organization: NEC Correlating Committee
Street Address:
City:
State:
Zip:
Submittal Date: Tue Jul 30 23:39:04 EDT 2024
Committee: NEC-P03

Copyright Assignment

I, CC Notes, hereby irrevocably grant and assign to the National Fire Protection Association (NFPA) all and full rights in copyright in this Public Comment (including both the Proposed Change and the Statement of Problem and Substantiation). I understand and intend that I acquire no rights, including rights as a joint author, in any publication of the NFPA in which this Public Comment in this or another similar or derivative form is used. I hereby warrant that I am the author of this Public Comment and that I have full power and authority to enter into this copyright assignment.

By checking this box I affirm that I am CC Notes, and I agree to be legally bound by the above Copyright Assignment and the terms and conditions contained therein. I understand and intend that, by checking this box, I am creating an electronic signature that will, upon my submission of this form, have the same legal force and effect as a handwritten signature



Correlating Committee Note No. 401-NFPA 70-2024 [Global Input]

Submitter Information Verification

Committee: NEC-AAC

Submittal Date: Fri May 10 12:35:51 EDT 2024

Committee Statement

Committee Statement: The Correlating Committee directs the CMPs to review all references to requirements in Chapters 7 & 8 for accuracy in light of the relocation of requirements occurring in the First Draft.

Ballot Results

✔ **This item has passed ballot**

12 Eligible Voters

1 Not Returned

11 Affirmative All

0 Affirmative with Comments

0 Negative with Comments

0 Abstention

Not Returned

McDaniel, Roger D.

Affirmative All

Ayer, Lawrence S.

Bowmer, Trevor N.

Hickman, Palmer L.

Holub, Richard A.

Jackson, Peter D.

Kendall, David H.

Manche, Alan

Osborne, Robert D.

Porter, Christine T.

Schultheis, Timothy James

Williams, David A.

