



Public Comment No. 1652-NFPA 70-2024 [Global Input]

This Global Public Comment is for CMP-12 to review the use of the terms "overcurrent", "overcurrent protective devices" and "overcurrent protection".

Additional Proposed Changes

<u>File Name</u>	<u>Description</u>	<u>Approved</u>
CMP-12_OCPD_TG-4_CMP-10.pdf	CMP-12_OCPD_TG-4 CMP-10	
All_CMP_Comments_Files_from_CMP-10_TG-4.pdf	All CMP Comments Files from CMP-10 TG-4	

Statement of Problem and Substantiation for Public Comment

This Public Comment is submitted on behalf of a Task Group formed under the purview of Code Making Panel 10 consisting of Randy Dollar, Thomas Domitrovich, Jason Doty, Diane Lynch, Alan Manche, Nathan Philips, David Williams, and Danish Zia. This Public Comment, along with other Public Comments, was developed with the goal of improving usability and accuracy on requirements associated with overcurrent protective devices.

The Task Group reviewed all instances of the term "overcurrent", "overcurrent protective devices" and "overcurrent protection" and provided recommended changes to align proposed and current defined terms.

For consistency, the task group chose to use the full defined term "overcurrent protective device" in the title of all sections or subdivisions and the acronym "OCPD" or "OCPDs" when used in the body of each code section.

The term overcurrent protection applies to the application of an overcurrent protective device OCPD, to protect conductors and equipment.

Two documents are attached: One for your specific code panel and the other is a comprehensive document illustrating all of the code-wide comments made by this task group.

The current term "Overcurrent Protective Device, Branch-Circuit" is being deleted and the new defined term "Overcurrent Protective Device (OCPD)" will be used instead.

The following are the proposed terms being submitted to CMP-10.

PC 1639 Overcurrent Protection.
Automatic interruption of an overcurrent

PC 1636 Overcurrent Protective Device (OCPD).
A device capable of providing protection over the full range of overcurrent between its rated current and its interrupting rating. (CMP-10)

Informational Note 1: Prior editions of NFPA 70 included the defined term "branch circuit overcurrent protective device" for overcurrent protective devices suitable for providing protection for service, feeder and branch circuits. This term has been revised to a generalized term of "overcurrent protective device" (OCPD). The specific requirements using this term may include modifiers (such as branch OCPD, feeder OCPD, service OCPD) to specify location or application of the OCPD, or to specify variations (such as supplementary OCPD).

Informational Note 2: See 240.7 for a list of overcurrent protective devices suitable for providing protection for service, feeder, branch circuits and equipment.

Related Item

• Global PI 4050 • PC 1636 • PC 1639

Submitter Information Verification

Submitter Full Name: David Williams
Organization: Delta Charter Township
Street Address:
City:
State:
Zip:
Submittal Date: Sun Aug 25 21:51:35 EDT 2024
Committee: NEC-P12

CMP-10 TG-4 Review of Overcurrent Language for the Articles under the purview of CMP-12

CMP	NEC Section (using First Draft of 2026 NEC)	Current Language	"New" Language
12	Article 610		
	610. Part V	Overcurrent Protection	Fine as is
	610.41(A)	Overcurrent Devices	OCPDs
	610.43(A)(1)	Branch Circuit Overcurrent Device	OCPD
	610.53 Title	Overcurrent Protection	Fine as is
	610.53	be protected from Overcurrent	shall be provided with overcurrent protection
	610.53	Overcurrent Devices	OCPDs
	610.53(B)	Branch Circuit Overcurrent Devices	OCPDs
12	Article 620		
	620.12(A)(4)	Overcurrent Protection	Fine as is
	620.22(A)(2) Title	Overcurrent protective device	Fine as is
	620.22(A)(2)	Overcurrent Device protecting	branch-circuit OCPD
	620.22(A)(2)	Overcurrent Device	OCPD
	620.22(B)	Overcurrent Device protecting	branch-circuit OCPD
	620.22(B)	Overcurrent Device	OCPD
	620.25 Title	Overcurrent Devices	Overcurrent Protective Devices
	620.25. (X2)	Overcurrent Devices	OCPDs
	620.53	Overcurrent protective device	OCPD
	620.54	Overcurrent protective device	OCPD
	620.55	Overcurrent protective device	OCPD
	Art 620 Part VII	Overcurrent Protection	Fine as is
	620.61	Overcurrent Protection	Fine as is
	620.61(A). (X2)	be protected against Overcurrent	shall be provided with overcurrent protection
	620.62(A)	Overcurrent protective devices, (OCPD)	OCPDs
	620.62(B)	OCPDs	Fine as is
	620.62(C)	OCPDs. And. Overcurrent Devices	Fine as is. And. OCPDs
	620.62	Overcurrent protective devices	OCPDs
	620.65. (X3)	Overcurrent Devices	OCPDs
12	Article 625		
	625.60(C). (X4)	Overcurrent Protection	Fine as is
12	Article 627		
	627.41	Overcurrent Protection	Fine as is
	627.41(A)	Overcurrent Protection	Fine as is

	627.41(B)	Overcurrent Devices	OCPDs
12	Article 630		
	630.12	Overcurrent Protection	Fine as is
	630.12	Overcurrent Device	OCPD
	630.12(A). (X2)	Overcurrent Protection	Fine as is
	630.12(A). (X5)	Overcurrent Device	OCPD
	630.13	Overcurrent Protection	Fine as is
	630.32	Overcurrent Protection	Fine as is
	630.32	Overcurrent Device	OCPD
12	Article 640		
	640.9(C)	Overcurrent Protection	Fine as is
	640.22	Overcurrent protection devices	OCPDs
	640.22	Overcurrent Devices	OCPDs
	640.43	Overcurrent protection devices	OCPDs
12	Article 645		
	645.27	Overcurrent protective devices, (OCPD)	OCPDs
	645.27	Overcurrent protective devices	OCPDs
12	Article 646		
	646.7. (X11)	Overcurrent Protection	Fine as is
12	Article 647		
	647.5	Overcurrent Protection	Fine as is
12	Article 650		
	650.9	Overcurrent Protection	Fine as is
	650.9	Overcurrent Device	OCPD
12	Article 660		
	660.7	Overcurrent Protection	Fine as is
	660.7(A)	Overcurrent protective devices	OCPDs
	660.7(B)	Overcurrent Devices	OCPDs
	660.7(B)	Overcurrent Protection	Fine as is
	660.9	Overcurrent Devices	OCPDs
12	Article 665		
	665.24	Overcurrent Protection	Fine as is
12	Article 668		
	668.4(C)(2)	Overcurrent Protection	Fine as is
	668.21	Overcurrent Protection	Fine as is

	668.21	Overcurrent Device	OCPD
12	Article 669		
	669.9	Overcurrent Protection	Fine as is
	669.9	be protected from Overcurrent	shall be provided with overcurrent protection
12	Article 670		
	670.1	Overcurrent Protection	Fine as is
	670.4(B). (X3)	Overcurrent Protection	Fine as is
	670.5. (X4)	Overcurrent Protection	Fine as is
	670.5(C). (X2)	Overcurrent protective device	OCPD
12	Article 685		
	685.10.	Overcurrent Devices	OCPDs

CMP-10 TG-4 Review of Overcurrent Language for the Articles under the purview of CMP-1

CMP	NEC Section (using First Draft of 2026 NEC)	Current Language	"New" Language
1	Article 110		
	110.10.	overcurrent protective devices	OCPDs
	110.10.	circuit protective devices	Fine as is
	110.26(C)(2)	overcurrent devices	OCPD
	110.26(C)(3)	overcurrent devices	OCPD
	110.52	Overcurrent protection	Fine as is
	110.52	Overcurrent	Motor-operated Equipment shall be provided with overcurrent protection
	110.52	Overcurrent	Transformers shall be provided with overcurrent protection

CMP-10 TG-4 Review of Overcurrent Language for the Articles under the purview of CMP-2

CMP	NEC Section (using First Draft of 2026 NEC)	Current Language	"New" Language
2	Article 100		
	Branch Circuit (Branch-Circuit)	overcurrent device	overcurrent protective device (OCPD)
2	Article 120		
	120.5(E)	overcurrent device	OCPD
	120.7(B)	overcurrent protective device	OCPD
	120.87(3)	Overcurrent protection	Fine as is
2	Article 210		
	210.4(A)	branch-circuit overcurrent protective device, OCPD	Fine as is
	210.4(C)	branch-circuit OCPD	Fine as is
	210.11(B)	branch-circuit OCPD	Fine as is
	210.12(A)	branch-circuit OCPD (X-8)	Fine as is
	210.18	overcurrent device OCPD (X-2)	Fine as is
	210.19(A)(1)EX	branch-circuit OCPD	Fine as is
	210.20.	Overcurrent protection	Fine as is
	210.20.	branch-circuit OCPD	Fine as is
	210.20(A)	branch-circuit OCPD	Fine as is
	210.20(C)	branch-circuit OCPD	Fine as is
	T-210.24	Overcurrent protection	Fine as is
2	Annex D		
		Overcurrent Protection	CMP-2 To review references to OCPD and the revised terms.
	D3. (X2)		
	D3a. (X8)	Branch-Circuit OCPD	CMP-2 to Review
	D3a.	Overcurrent Protection	CMP-2 to Review
	D3a. (X2)	Branch-Circuit OCPD	CMP-2 to Review

CMP-10 TG-4 Review of Overcurrent Language for the Articles under the purview of CMP-3

CMP	NEC Section (using First Draft of 2026 NEC)	Current Language	"New" Language
3	Article 100		
	Fault Managed Power.	Overcurrent protection	Fine as is
	Fire Alarm Circuit	Overcurrent device	overcurrent protective device (OCPD)
3	Article 300		
	300.5-T	Overcurrent Protection	Fine as is
	300.17(l)	Overcurrent Device	OCPD
	300.28(C)(3). (X5)	Overcurrent Protection	Fine as is
3	Article 590		
	590.6(A)	Overcurrent Protection	Fine as is
	590.6(B)	be protected from Overcurrent	shall be provided with overcurrent protection
	590.9. Title	Overcurrent protective device	Fine as is
	590.9(A)	Overcurrent protective devices	OCPDs
	590.9(B) Title	Service Overcurrent protective devices	Fine as is
	590.9(B)	Overcurrent protective devices	OCPDs
3	Article 721		
	721.50(A)	Overcurrent	Fine as is
3	Article 722		
	722.1	Overcurrent Protection	Fine as is
3	Article 724	Class 1	
	724.40(B). (X3)	Overcurrent Devices	OCPDs
	724.40(B). (X2)	Overcurrent Device	OCPD
	724.40(B). (X2)	Overcurrent Protection	Fine as is
	724.43. (X4)	Overcurrent Protection	Fine as is
	724.45	Overcurrent Device	OCPD
	724.45. (X3)	Overcurrent Devices	OCPDs
	724.45(A)	Overcurrent Devices	OCPDs
	724.45(B)	Overcurrent Protection	Fine as is
	724.45(B)	Overcurrent Device	OCPD
	724.45(C). (X2)	Overcurrent protective devices	OCPDs
	724.45(D)	Overcurrent Protection	Fine as is
	724.45(E)	Overcurrent Protection	Fine as is
3	Article 725		
	725.1 In	Overcurrent Protection	Fine as is

	725.127	Overcurrent Device	OCPD
3	Article 760		
	760.41(B)	Overcurrent protective device	OCPD
	760.41(B)	Overcurrent protection devices	OCPDs
	760.43. (X3)	Overcurrent Protection	Fine as is
	760.45. Title	Overcurrent device	Overcurrent protective device
	760.45	Overcurrent protection devices	OCPDs
	760.45 Ex 1 & 2	Overcurrent Protection	Fine as is
	760.121(B)	Branch-Circuit Overcurrent protective device	OCPD
	760.121(B)	Overcurrent protection devices	OCPDs
	760.127	Overcurrent Protection	Fine as is
	760.127	Overcurrent Device	OCPD
3	Article 794		
	794.1	Overcurrent Protection	Fine as is

CMP-10 TG-4 Review of Overcurrent Language for the Articles under the purview of CMP-4

CMP	NEC Section (using First Draft of 2026 NEC)	Current Language	"New" Language
4	Article 690		
	690.2	PV dc Overcurrent protective devices	PV dc OCPDs
	690.8	Overcurrent Device	OCPD and OCPDs
	690.9. Title	Overcurrent Protection	Fine as is
	690.9(A). (X2)	be protected from Overcurrent	shall be provided with overcurrent protection
	690.9(A)(1). Title	Overcurrent Protection	Fine as is
	690.9(A)(1).	Overcurrent protective devices	OCPDs
	690.9(A)(2). Title	Overcurrent Protection	Fine as is
	690.9(A) (2)	be protected from Overcurrent	shall be provided with overcurrent protection
	690.9(A) (2) In	Overcurrent protection	Fine as is
	690.9(A) (2) In	Overcurrent device	OCPD
	690.9(A)(3)	Overcurrent	Fine as is
	690.9(B)	shall be permitted to prevent overcurrent of conductors	Fine as is
	690.9(B)	Overcurrent device	OCPD and OCPDs
	690.9(C)	Overcurrent protective device and Devices	OCPD and OCPDs
	690.31(E)	Overcurrent protective devices	OCPDs
	690.45	Overcurrent protective device	OCPD
	690.45	Overcurrent Device	OCPD
4	Article 692		
	692.8. Title	Overcurrent Device	Overcurrent Protective Devices
	692.8	Overcurrent protective device	OCPDs
	692.9	Overcurrent Protection	Fine as is
	692.9	Overcurrent Devices	OCPDs
4	Article 694		
	694.7(D)	Overcurrent Device	OCPD
	694.12(B). Title	Overcurrent Device	Overcurrent Protective Device
	694.12(B)(2). Title	Overcurrent Devices	Overcurrent Protective Devices
	694.12(B)(2)	Overcurrent Devices	OCPDs
	694.15	Overcurrent Protection	Fine as is
	694.15	Overcurrent Devices	OCPDs
	694.15 In	Overcurrent Protection	Fine as is
	694.15(B)(1)	Overcurrent Protection	Fine as is
	694.15(C)	Overcurrent Devices	OCPDs

4	Article 705		
	705.11(C). Title	Overcurrent Protection	Fine as is
	705.11(C)	be protected from overcurrent	have overcurrent protection
	705.11(C)(1). (1) (2) (3)	Overcurrent protective device	OCPD
	705.11(C)(2)	Overcurrent protection devices	OCPDs
	705.12(A)(2). (X4)	Overcurrent Device	OCPD
	705.12(A)(3)	Overcurrent Devices	OCPDs
	705.12(B)	(Multiple) Overcurrent Device and (s)	OCPD. And OCPDs
	705.12(B)	(Warning labels) Overcurrent Device and (s)	Overcurrent Protective Device and Devices
	705.28(B)Ex.1	Overcurrent Devices	OCPDs
	705.28(B)Ex.3	Overcurrent Device	OCPD
	705.30. Title	Overcurrent Protection	Fine as is
	705.30(A). (X2)	Overcurrent Protection	Fine as is
	705.30(A)	Overcurrent Devices	OCPDs
	705.30.(C)	Overcurrent Devices	OCPDs
	705.30.(F)	Overcurrent Protection	Fine as is
	705.70.	Overcurrent Devices	OCPDs
	705.70.	Overcurrent Protection	Fine as is

CMP-10 TG-4 Review of Overcurrent Language for the Articles under the purview of CMP-5

CMP	NEC Section (using First Draft of 2026 NEC)	Current Language	"New" Language
5	Article 100		
	Ground-Fault Current Path, Effective	overcurrent protective device	overcurrent protective device (OCPD)
	Ground-Fault Protection of Equipment	overcurrent device	overcurrent protective device (OCPD)
5	Article 200		
	200.10(E)	overcurrent device	OCPD
5	Article 250		
	250.4(A)(5). Title	Overcurrent protective Device	Fine as is
	250.4(A)(5)	Overcurrent Device	OCPD
	250.4(B)(4)	Overcurrent Devices	OCPDs
	250.30(A)(1)	Overcurrent Device	OCPD
	250.30(A)(1)	Overcurrent Devices	OCPDs
	250.32(B)(2). (X4)	Overcurrent Protection	Fine as is
	250.32(C)(2). (X4)	Overcurrent Protection	Fine as is
	250.35(B)	Overcurrent Protection	Fine as is
	250.36(D)	Overcurrent Device	Fine as is
	250.36(E)(1)	Overcurrent Device	OCPD
	250.102(B)(2)	Overcurrent Protection	Fine as is
	250.102(D). (X3)	Overcurrent Devices	OCPDs
	250.118(A)(5)	Overcurrent Devices	OCPDs
	250.118(A)(6)	Overcurrent Devices	OCPDs
	250.118(A)(7)	Overcurrent Devices	OCPDs
	250.122(C)	Overcurrent Device	OCPD
	250.122(F)(1). (X3)	Overcurrent protective device	OCPD
	250.122(G)	Overcurrent Device	OCPD
	250.142. (X2)	Overcurrent Device	OCPD
	250.148	Overcurrent Device	OCPD
	250.164	Overcurrent Device	OCPD
	250.166	Overcurrent Protection	Fine as is
	250.169	Overcurrent Devices	OCPD
5	Article 270		
	270.4(A)(5)	Overcurrent Device	OCPD
	270.4(B)(4)	Overcurrent Devices	OCPDs
	270.30(A)(1)	Overcurrent Devices	OCPDs

	270.32(B)(2). (X4)	Overcurrent Protection	Fine as is
	270.32(C)(2). (X4)	Overcurrent Protection	Fine as is
	270.35(B)	Overcurrent Protection	Fine as is
	270.35(B)	Overcurrent protective device	OCPD
	270.36(D)	Overcurrent Device	OCPD
	270.36(E)	Overcurrent Devices	OCPDs
	270.102(C)(2)	Overcurrent Protection	Fine as is
	270.102(D)	Overcurrent Device	OCPDs
	270.114(C)(3)	Overcurrent setting	CMP to review Language based on new terms
	270.118	Overcurrent Devices	OCPDs
	270.142	Overcurrent Devices	OCPDs
	270.148(B)	Overcurrent Device	OCPD
	270.164(B)	Overcurrent Device	OCPD
	270.166(A)	Overcurrent Protection	Fine as is
	270.169	Overcurrent Devices	OCPDs

CMP-10 TG-4 Review of Overcurrent Language for the Articles under the purview of CMP-6			
CMP	NEC Section (using First Draft of 2026 NEC)	Current Language	"New" Language
6	Article 310		
	310.10(G).	Overcurrent Protection	Fine as is
	310.15(A)	Overcurrent Protection	Fine as is
	310.16-T	Overcurrent Protection	Fine as is
	310.17-T	Overcurrent Protection	Fine as is
6	Article 335		
	335.90.	Overcurrent Protection	Fine as is
6	Article 382		
	382.4	Supplementary Overcurrent Protection	Supplementary Overcurrent Protective Device
6	Article 400		
	400.16	Overcurrent Protection	Fine as is
	400.16	protected against Overcurrent	shall be provided with overcurrent protection
6	Article 402		
	402.14 (X2)	Overcurrent Protection	Fine as is

CMP-10 TG-4 Review of Overcurrent Language for the Articles under the purview of CMP-7

CMP	NEC Section (using First Draft of 2026 NEC)	Current Language	"New" Language
7	Article 100		
	Service Equipment, Mobile Home	overcurrent protective devices	overcurrent protective devices (OCPDs)
7	Article 545		
	545.24	Branch-circuit overcurrent protective device	Branch-circuit OCPD
	545.24(B) Title	Branch Circuit Overcurrent Protection Device	Overcurrent protective devices
	545.24(B)	a Branch Circuit Overcurrent Protective Device	an OCPD
7	Article 547		
	547.41(A)(6). (X2)	Overcurrent Protection	Fine as is
	547.41(B)	Overcurrent Protection	Fine as is
	547.42	Overcurrent Protection	Fine as is
7	Article 550		
	550.11(B). Title	Branch-Circuit protective equipment	Branch-Circuit Overcurrent Protection
	550.11(B)	Overcurrent Protection	Fine as is
	550.11(B)	Branch-Circuit Overcurrent Devices	OCPDs
	550.11(B)	Overcurrent protection size	OCPD rating
	550.15(E)	Branch-circuit overcurrent protective device	OCPD
	550.32	Overcurrent Protection	Fine as is
7	Article 551		
	551.31(A)	Overcurrent protective device	OCPD
	551.31(C)	Overcurrent protective device	OCPD
	551.31(D)	Overcurrent Protection	Fine as is
	551.42	Overcurrent Protection	Fine as is
	551.43. Title	Branch-Circuit protection	Branch-Circuit Overcurrent Protection
	551.43(A)	Branch Circuit Overcurrent Devices	Branch-Circuit OCPDs
	551.43(A)(3)	Overcurrent Protection	Fine as is
	551.45(C)	Overcurrent protective device	OCPD
	551.47(Q)	Overcurrent protective device	OCPD
	551.47(R)	Overcurrent Protection	Fine as is
	551.47(S)	Overcurrent Protection	Fine as is
	551.74	Overcurrent Protection	Fine as is
7	Article 552		
	552.10.(E) Title	Overcurrent Protection	Fine as is
	552.10(E)(1)	Overcurrent protective devices	OCPDs

	T-552.10(E)(1)	Overcurrent Protection	Fine as is
	552.10(E)(4). (X2)	Overcurrent protective device	OCPD
	552.42(A)	Branch Circuit Overcurrent Devices	OCPDs
	552.42(A)	Overcurrent Protection	Fine as is
	552.45(C)	Overcurrent protective device	OCPD
	552.46(A) IN	Overcurrent Protection	Fine as is
	552.47(P)	Overcurrent protective device	OCPD
	552.47(Q)	Overcurrent Protection	Fine as is
7	Article 555		
	555.53	Overcurrent protective device	OCPD
7	Article 675		
	675.6	Branch Circuit Overcurrent Protective Device	OCPD
	675.7	Branch Circuit Overcurrent Protective Devices	OCPDs
	675.8	Overcurrent Protection	Fine as is
7	Article 682		
	682.15(B)	Feeder Overcurrent protective device	Feeder OCPD

CMP-10 TG-4 Review of Overcurrent Language for the Articles under the purview of CMP-8			
CMP	NEC Section (using First Draft of 2026 NEC)	Current Language	"New" Language
8	Article 312		
	312.11. Title	Overcurrent Devices	Overcurrent Protective Device
	312.11	Overcurrent Devices	OCPDs
	312.11(A). (X3)	Overcurrent Device	OCPDs
	312.11(B)	Overcurrent Devices	OCPDs
	312.11(B)(1)	Overcurrent Device	OCPD
8	Article 366		
	366.12	Overcurrent Devices	OCPDs
	366.56(D)	Overcurrent Protection	Fine as is
8	Article 368		
	368.17(A). Title	Overcurrent Protection	Fine as is
	368.17	Overcurrent Protection	Fine as is
	368.17(A)	Protected against Overcurrent	shall be provided with overcurrent protection
	368.17(B). (X2)	Overcurrent Protection	Fine as is
	368.17(B)	Overcurrent Device	OCPD
	368.17(C)	Overcurrent Devices	OCPDs
	368.17(C)Ex.2	Branch-Circuit Overcurrent Device	Branch-Circuit OCPD
	368.17(C)Ex.3	Overcurrent Device	OCPD
	368.17(C)Ex.4	Branch-Circuit overcurrent plug-in device	CMP to review Language based on new terms
	368.17(D). Title	Overcurrent Protection	Fine as is
	368.17(D)	Protected against Overcurrent	shall be provided with overcurrent protection
8	Article 370		
	370.23. Title	Overcurrent Protection	Fine as is
	370.23	Protected against Overcurrent	shall be provided with overcurrent protection
8	Article 371		
	371.17. Title	Overcurrent Protection	Fine as is
	371.17	Overcurrent Protection	Fine as is
	371.17 (A)-(C). Titles	Overcurrent Protection	Fine as is
	371.17(A)-(C)	Protected against Overcurrent	shall be provided with overcurrent protection
	371.17(D)	Protected against Overcurrent	shall be provided with overcurrent protection
	371.17(F)	Overcurrent	shall be provided with overcurrent protection
	371.17(G)	Overcurrent Protection	
	371.17(G)Ex	Overcurrent Protection	Fine as is
	371.17(G)Ex	Overcurrent Device	OCPD

CMP-10 TG-4 Review of Overcurrent Language for the Articles under the purview of CMP-9

CMP	NEC Section (using First Draft of 2026 NEC)	Current Language	"New" Language
9	Article 265		
	265.18	Overcurrent Device	OCPD
	265.20.	Overcurrent Protection	Fine as is
	265.20.	Overcurrent protective devices	OCPDs
	265.20.	Overcurrent Devices	OCPDs
9	Article 266		
	266.1	Overcurrent Protection	Fine as is
	266.5	Overcurrent Protection	Fine as is
	266.5	Protected against overcurrent	shall be provided with overcurrent protection
	266.5	Overcurrent Device	OCPD
9	Article 268		
	268.2. (X2)	Overcurrent Protection	Fine as is
	268.70(F)	Overcurrent Devices	OCPDs
	268.82. (X4)	Overcurrent Protection	Fine as is
	Art. 268 Part VII	Overcurrent Protection	Fine as is
	268.90.	Overcurrent Device	OCPD
	268.90.	Overcurrent Devices	OCPDs
	268.91	Overcurrent Device	OCPD
	268.92	Overcurrent Devices	OCPDs
	268.93	Overcurrent Device	OCPD
9	Article 450		
	450.5 (previously 450.3). (X3)	overcurrent protection	Fine As Is
	450.5(A) and Table. (X3)	overcurrent protection	Fine As Is
	Table 450.5(A) Footnote 2. (X4)	overcurrent device	OCPD
	450.5(B)	overcurrent protection	Fine As Is
	Table 450.5(B) and Table (X2)	overcurrent protection	OCPD
	Table 450.5(B) Footnote 2. (X3)	overcurrent device	OCPD
	Table 450.5(B) Footnote 3	overcurrent protection	OCPD
	450.6(A) Title	overcurrent protection	Fine As Is
	450.6(A) (X3)	overcurrent device	OCPD
	450.6(A) Exception	overcurrent device	OCPD
	450.7(A)(1). (X2)	overcurrent protection	OCPD
	450.7(A)(2). Title	overcurrent protection	Fine As Is

		overcurrent sensing device	Fine As Is
	450.7(A)(2)	overcurrent protection	OCPD
		overcurrent device	OCPD
		branch or feeder protective devices	branch or feeder OCPDs
	450.7(A)(3)	overcurrent device	OCPD
	450.7(B)(2)	overcurrent protection	Fine As Is
	450.7(B)(2)(a)	overcurrent protective device	OCPD
	450.7(B)(2)(b)	overcurrent protection	OCPD
	450.7(B)(2)(b)	overcurrents	Fine As Is
	450.7(B)(2)(b) Exception	overcurrent device	OCPD
	450.8(A). (X2)	overcurrent protection	Fine As Is
	450.8(A)(1)	overcurrent protection	Fine As Is
	450.8(A)(2)	overcurrent protection	Fine As Is
	450.8(A)(3)	protective device	OCPD
	450.8(A)(4)(a)	protective device	OCPD
	450.8(B). Title	Overcurrent Protection	Fine As Is
	450.8(B)	overcurrent device	OCPD
	450.9	overcurrent protection	Fine As Is
	450.9	protective devices (2x)	OCPDs
	450.23(A)(1)(d) Informational Note	overcurrent protection	OCPD
	450.23(B)(1) Informational Note 2	overcurrent protection	OCPD
9	Article 495		
	495.62. Title	Overcurrent Protection	Fine As Is
	495.72	Overcurrent Relay	Fine As Is

CMP-10 TG-4 Review of Overcurrent Language for the Articles under the purview of CMP-10			
CMP	NEC Section (using First Draft of 2026 NEC)	Current Language	"New" Language
10	Article 100		
	Circuit Breaker	Overcurrent	Fine as is
	Coordination, Selective. (Selective Coordination)	Overcurrent condition	Fine as is
	Coordination, Selective. (Selective Coordination)	overcurrent protective devices	overcurrent protective devices (OCPDs)
	Coordination, Selective. (Selective Coordination)	overcurrents	Fine as is
	Coordination, Selective. (Selective Coordination)	overcurrent protective device	overcurrent protective device (OCPD)
	Current Limiting (as applied to overcurrent protection devices)	overcurrent protection devices	overcurrent protective devices (OCPDs)
	Feeder	final branch-circuit overcurrent protective device	overcurrent protective device (OCPD)
	Fuse	overcurrent protective device	overcurrent protective device (OCPD)
	Fuse	overcurrent	Fine as is
	Fuse, Electronically Actuated	overcurrent protective device	overcurrent protective device (OCPD)
	Fuse, Electronically Actuated	overcurrent	Fine as is
	Overcurrent	Overcurrent protection	Fine as is
	Overcurrent Protective Device, Branch-Circuit	Revise with the term Overcurrent Protective Device. (OCPD)	
	Overcurrent Protective Device, Supplementary (need to Revise term with acronym)	overcurrent protective device	overcurrent protective device (OCPD)
	Panelboard	overcurrent devices	overcurrent protective devices (OCPDs)
	Surge-Protective Device (SPD). (X2)	overcurrent device. (X2)	overcurrent protective device (OCPD)
	Switchboard	overcurrent	overcurrent protective devices (OCPDs)
	Tap Conductor	Overcurrent protection	Fine as is
10	Article 215		
	215.1	Overcurrent protection	Fine as is
	215.4(A)(1)Ex.1	overcurrent devices protecting the feeders	feeder OCPD
	215.4(A)(1)Ex.3	overcurrent device	OCPD
	215.5 Title	Overcurrent protection	Fine as is
	215.5	Feeders shall be protected against overcurrent	Feeders shall be provided with overcurrent protection in accordance with Article 240, Parts I
	215.5	overcurrent device	OCPD
	215.5Ex	overcurrent device protecting the feeders	feeder OCPDs
	215.5Ex	overcurrent device	OCPD

	215.18(B)	branch circuit overcurrent devices	OCPDs
10	Article 225		
	225.40. Title	Overcurrent protective devices	Fine as is
	225.40.	feeder overcurrent device (x2)	feeder OCPD
	225.40.	branch circuit overcurrent devices	Branch circuit OCPDs
	225.42(B)	branch circuit overcurrent devices	OCPDs
10	Article 230		
	230.7 Ex.2	Overcurrent protection	Fine as is
	230.42(A)(1)	overcurrent device (X3)	OCPD
	230.82(6)	Overcurrent protection	Fine as is
	230.82(7)	Overcurrent protection	Fine as is
	230.82(8)	Overcurrent protection	Fine as is
	230.82(9)	Overcurrent protection	Fine as is
	230.82(10)	Overcurrent protection	Fine as is
	230 Part VII	Overcurrent protection	Fine as is
	230.90(A)	overcurrent device	OCPD
	230.90(A)Ex.3	overcurrent device	OCPD
	230.90(B)	overcurrent device	OCPD
	230.91	overcurrent device (X2)	OCPD
	230.92	overcurrent device (X4)	OCPDs and OCPD
	230.93	overcurrent device	OCPD
	230.94	overcurrent device (X3)	OCPD
	230.94	Overcurrent protection (X2)	Fine as is
	230.95(A)	overcurrent device	OCPD
	230.95(B)	overcurrent device	OCPD
10	Article 240		
	240	Overcurrent Protection	Fine as is
	240.1 (X3)	Overcurrent protection	Fine as is
	240.2	branch-circuit Overcurrent protective devices	branch-circuit Overcurrent protective devices
	240.4. Title	Protection of Conductors	Overcurrent Protection of Conductors
	240.4	Protected against overcurrent	shall be provided with overcurrent protection in accordance with
	240.4(B). Title	Overcurrent devices	Overcurrent protective Devices
	240.4(B)	Overcurrent device	OCPD
	240.4(B)	Overcurrent protective device	OCPD

	240.4(C). Title	Overcurrent devices	Overcurrent protective Devices
	240.4(C). (X2)	Overcurrent device.	OCPD
	240.4(D)	Overcurrent Protection	Fine as is
	240.4(D)(1)	Overcurrent protection	Fine as is
	240.4(D)(1)(2)		(a) OCPDs in accordance with 240.7 shall be marked for use with 18 AWG copper conductor (b) Delete (c) change to (b)
	240.4(D)(2)	Overcurrent protection	Fine as is
	240.4(D)(2)(2)		(a) OCPDs in accordance with 240.7 shall be marked for use with 16 AWG copper conductor (b) Delete (c) change to (b)
	240.4(D)(3)	Overcurrent protection	Fine as is
	240.4(D)(3)(2)		(a) Fuses and circuit breakers in accordance with 240.7 marked for use with 14 AWG copper clad aluminum conductor (b) Delete
	240.4(D)(3)(2)		OCPDs in accordance with 240.7 shall be marked for use with 14 AWG copper-clad aluminum conductor
	240.4(E)	Protected against overcurrent	shall be permitted to have overcurrent protection in accordance with the following
	240.4(F)	Overcurrent protection	Fine as is
	240.4(F)	Overcurrent protective device	OCPD
	240.4(G). (X2)	Overcurrent protection	Fine as is
	240.4(H)	Protected against overcurrent	shall be provided with overcurrent protection in accordance with
	240.5	Protected against overcurrent	shall be provided with overcurrent protection in accordance with
	240.5(A)	Overcurrent device	OCPD
	240.5(A)	Protected against overcurrent	Fixture wires shall be provided with overcurrent protection in accordance with
	240.5(A)	Supplementary overcurrent protection	Fine as is
	240.5(B) Title	Branch-circuit overcurrent device.	Branch-Circuit Overcurrent protective Devices

	240.9	Protection of conductors against overcurrent	Fine as is
	240.10. Title	Supplementary Overcurrent protection	Fine as is
	240.10.	Supplementary overcurrent protection	Fine as is
	240.10.	Branch-Circuit overcurrent devices	OCPDs
	240.10.	Supplementary overcurrent devices	Supplementary OCPDs
	240.11. (X2)	Feeder overcurrent protective devices.	Feeder OCPDs
	240.11. (X2)	Service overcurrent protective device.	Service OCPD
	240.15(A). Title	Overcurrent device	Overcurrent protective device required
	240.15(A)	Overcurrent device	OCPD
	240.15(A)	Overcurrent trip. Overcurrent relay	Fine as is
	240.15(B) Title	Overcurrent device	Circuit breaker as Overcurrent protective device
	240.16	Branch circuit overcurrent protective devices	OCPDs
	240.21	Overcurrent Protection	Fine as is
	240.21	overcurrent protective device	OCPD
	240.21 (A)	Overcurrent Protection	Fine as is
	240.21 (B)	Overcurrent Protection	Fine as is
	240.21 (B) (1) (1) (b)	Overcurrent device(s)	OCPDs
	240.21 (B) (1) (1) (b)	overcurrent protective device	OCPD
	240.21 (B)(1) (1) (4)	Overcurrent device	OCPD
	240.21 (B) (1)(1) (4) In	Overcurrent Protection	Fine as is
	240.21 (B) (2) (1)	Overcurrent device	OCPD
	240.21 (B) (2) (2)	Overcurrent devices	OCPDs
	240.21 (B) (3) (1)	Overcurrent device	OCPD
	240.21 (B) (3) (2)	Overcurrent device	OCPD
	240.21 (B) (4) (3)	Overcurrent device	OCPD
	240.21 (B) (4) (4)	Overcurrent device	OCPD
	240.21 (B) (4) (4)	Overcurrent devices	OCPDs
	240.21 (B) (5) (2)	Overcurrent device	OCPD
	240.21 (B) (5) (2)	Overcurrent devices	OCPDs
	240.21 (B) (5) (3)	Overcurrent device	OCPD
	240.21 (C). (X2)	Overcurrent Protection	Fine As Is
	240.21 (C) (1). Title	Title change	Overcurrent Protective Device
	240.21 (C) (1)	"...protected by overcurrent protection..."	Fine As Is
	240.21 (C) (1)	Overcurrent protective device	OCPD
	240.21 (C) (2) (1) (b)	Overcurrent device(s)	OCPDs

	240.21 (C) (2) (1) (b)	Overcurrent device	OCPD
	240.21 (C) (2) (4)	Overcurrent device	OCPD
	240.21 (C) (2) (4)	Overcurrent device	OCPD
	240.21 (C) (2) (4)	Overcurrent protection	Fine as is
	240.21 (C) (3) (2)	Overcurrent devices	OCPDs
	240.21 (C) (3) (3)	Overcurrent devices	OCPDs
	240.21 (C) (4) (2)	Overcurrent device	OCPD
	240.21 (C) (4) (2)	Overcurrent devices	OCPDs
	240.21 (C) (4) (3)	Overcurrent device	OCPD
	240.21 (C) (5)	Overcurrent Protection	Fine As Is
	240.21 (C) (6) (1)	Overcurrent device	OCPD
	240.21 (D)	Overcurrent devices	OCPDs
	240.21 (E)	.shall be permitted to be protected against overcurrent.	"..shall be permitted to have overcurrent protection.."
	240.21 (F)	.shall be permitted to be protected against overcurrent.	"..shall be permitted to have overcurrent protection.."
	240.21 (H) . (X 2)	Overcurrent Protection	Fine As Is
	240.22 . (X 2)	Overcurrent device	OCPD
	240.24(A)	Supplementary overcurrent protection	Fine as is
	240.24(A). (X 4)	Overcurrent protective devices	OCPDs
	240.24(B)	Overcurrent devices	OCPDs
	240.24(B)(1). Title	Feeder overcurrent protective devices	Feeder OCPDs
	240.24(B)(1)	Service overcurrent protective devices	Service OCPDs
	240.24(B)(2). TITLE	Branch-circuit overcurrent protective device	Fine as is
	240.24(B)(2).	Branch-circuit overcurrent protective device	Branch-Circuit OCPD
	240.24(C)	Overcurrent protective devices	OCPDs
	240.24(D)	Overcurrent protective devices	OCPDs
	240.24(E)	Overcurrent protective devices	OCPDs
	240.24(E)	Supplementary overcurrent protection	Fine as is
	240.24(E) (X 2)	Overcurrent protective devices	OCPDs
	240.24(F)	Overcurrent protective devices	OCPDs
	240.30(A)	Overcurrent devices	OCPDs
	240.32	Overcurrent devices	OCPDs
	240.33	Overcurrent devices	OCPDs
	240.86	Overcurrent device	OCPD
	240.86(B)	Overcurrent device	OCPD
	240.86(C)	Overcurrent device	OCPD

	240.87	Overcurrent device	OCPD
	240.90.	Overcurrent protection	Fine as is
	240.91(B). (X2)	Overcurrent device	OCPD
	240.92	Overcurrent device	OCPD
	240.92(A)	be protected	shall be provided with overcurrent protection
	240.92(C)	Overcurrent protection	Fine as is
	240.92(C)(1)(1)	Overcurrent device	OCPD
	240.92(C)(1)(2)	protective devices	Fine as is
	240.92(C)(1)(3)	Overcurrent devices	OCPDs
	240.92(C)(2)(1)	Overcurrent device	OCPD
	240.92(C)(2)(2) (X3)	Overcurrent devices	OCPDs
	240.92(C)(2)(3)	Overcurrent relaying	Fine as is
	240.92(C)(2)(4)	Overcurrent device	OCPD
	240.92(D)	Overcurrent protection	Fine as is
	240.92(D)(2). (X3)	Overcurrent devices	OCPDs
	240.92(D)(4)	Overcurrent device	OCPD
	240.92(E)	Overcurrent device	OCPD
	240.92(E)	Overcurrent protection	Fine as is
10	Article 242		
	242.14(ABC)	Overcurrent device	OCPD
	242.16	Overcurrent protection	Branch-circuit OCPD
10	Article 404		
	404.5	Overcurrent Devices	OCPDs
10	Article 408		
	408.4(A)	Overcurrent device	OCPD
	408.6 (X2)	Overcurrent protection devices	OCPDs
	408.36. Title	Overcurrent protection	Fine as is
	408.36. (X2)	Overcurrent protective device	OCPD
	408.36. (X3)	Overcurrent devices	OCPDs
	408.36(A)	Overcurrent protection	Fine as is
	408.36(B)	Overcurrent protection	Fine as is
	408.36(C)	Overcurrent device	OCPD
	408.36(D)	Overcurrent protection devices	OCPDs
	408.52	Overcurrent devices	OCPDs
	408.54	Overcurrent devices	OCPDs

	408.55	Overcurrent devices	OCPDs
--	--------	---------------------	-------

CMP-10 TG-4 Review of Overcurrent Language for the Articles under the purview of CMP-11

CMP	NEC Section (using First Draft of 2026 NEC)	Current Language	"New" Language
11	Article 409		
	409.21. TITLE	Overcurrent Protection	Fine as is
	409.21(A)	Overcurrent Protection	Fine as is
	409.21(B)	Protection	Overcurrent protection
	409.21(B)	overcurrent protective device	OCPD
	409.21(B)	Overcurrent Protection	Fine as is
	409.21(C). (X2)	overcurrent protective device	OCPD
	409.104	Overcurrent Devices	OCPDs
11	Article 430		
	430.10(A) In.	Overcurrent Device	OCPD
	430.22(G)(1)(1)	Overcurrent Protection	Fine as is
	430.22(G)(1)(2)	Overcurrent Protection	Fine as is
	430.22(G)(2)(1)	Overcurrent Protection	Fine as is
	430.22(G)(2)(2)	Overcurrent Protection	Fine as is
	430.28	Branch-Circuit protective device	OCPD
	430.28	Overcurrent Device	OCPD
	430.51	Overcurrent	Fine as is
	430.53(C)(5)	Overcurrent Protection	Fine as is
	430.55	Overcurrent Protection	Fine as is
	430.61	Overcurrents	Fine as is
	430.62(A)Ex.2	Feeder Overcurrent protective device	Feeder OCPD
	430.62(A)Ex.2	Overcurrent Protection	Fine as is
	430.62(B)	Feeder Overcurrent protective device	Feeder OCPD
	430.63Ex.	Feeder Overcurrent device	Feeder OCPD
	430.63Ex.	Overcurrent Protection	Fine as is
	430.72. Title	Overcurrent Protection	Fine as is
	430.72(A)	protected against overcurrent	shall be provided with overcurrent protection in accordance with
	430.72(A)	Branch-circuit overcurrent protective devices	OCPDs
	430.72(A)	protected against overcurrent	shall be provided with overcurrent protection in accordance with
	430.72(B). (X2)	Overcurrent Protection	Fine as is
	430.72(B)	Overcurrent Device	OCPD

	430.72(B)	Overcurrent Protection	Fine as is
	430.72(B)(1) (X3)	Overcurrent Protection	Fine as is
	430.72(B)(2) Title	Branch-circuit overcurrent protective device	Fine as is
	430.72(B)(2) (X2)	protective devices	OCPDs
	430.72(C)Ex.	Overcurrent Protection	Fine as is
	430.72(C)(3)	Overcurrent Devices	OCPDs
	430.72(C)(4)	Overcurrent Device	OCPD
	430.72(C)(5)	Protection	Overcurrent protection
	430.87	Overcurrent Device	OCPD
	430.94. (X2)	Overcurrent Protection	Fine as is
	430.94. (X3)	Overcurrent protective device	OCPD
	430.109(A)(7)	Overcurrent protection	Fine as is
	430.109(B)	Branch-circuit overcurrent device	branch-circuit OCPD
	430.111(A). (X2)	Overcurrent Device	Fine as is
	430.112 Ex.	Branch circuit protective device	Suggest CMP to Review
	430.206. Title	Overcurrent protection	Fine as is
	430.206(B)(2)	considered to have Overcurrent	Overload
	430.206(C)	Fault-Current protection	Suggest CMP to Review
	430.207	Overcurrent (overload)Relays	Fine as is
	430.207	Overcurrent Relays	Fine as is
11	Article 440		
	440.21	Overcurrent	Fine as is
	440.21	Overcurrent Protection	Fine as is
	440.22(B)(2)Ex.	Overcurrent device	OCPD
	440.52(B)	Overcurrent	shall be provided with overcurrent protection
11	Article 460		
	460.9. Title	Overcurrent Protection	Fine As Is
	460.9. (X3)	Overcurrent Device	OCPD
	460.25	Overcurrent Protection	Fine As Is
	460.28(B)	Overcurrent Device	OCPD

CMP-10 TG-4 Review of Overcurrent Language for the Articles under the purview of CMP-12

CMP	NEC Section (using First Draft of 2026 NEC)	Current Language	"New" Language
12	Article 610		
	610. Part V	Overcurrent Protection	Fine as is
	610.41(A)	Overcurrent Devices	OCPDs
	610.43(A)(1)	Branch Circuit Overcurrent Device	OCPD
	610.53 Title	Overcurrent Protection	Fine as is
	610.53	be protected from Overcurrent	shall be provided with overcurrent protection
	610.53	Overcurrent Devices	OCPDs
	610.53(B)	Branch Circuit Overcurrent Devices	OCPDs
12	Article 620		
	620.12(A)(4)	Overcurrent Protection	Fine as is
	620.22(A)(2) Title	Overcurrent protective device	Fine as is
	620.22(A)(2)	Overcurrent Device protecting	branch-circuit OCPD
	620.22(A)(2)	Overcurrent Device	OCPD
	620.22(B)	Overcurrent Device protecting	branch-circuit OCPD
	620.22(B)	Overcurrent Device	OCPD
	620.25 Title	Overcurrent Devices	Overcurrent Protective Devices
	620.25. (X2)	Overcurrent Devices	OCPDs
	620.53	Overcurrent protective device	OCPD
	620.54	Overcurrent protective device	OCPD
	620.55	Overcurrent protective device	OCPD
	Art 620 Part VII	Overcurrent Protection	Fine as is
	620.61	Overcurrent Protection	Fine as is
	620.61(A). (X2)	be protected against Overcurrent	shall be provided with overcurrent protection
	620.62(A)	Overcurrent protective devices, (OCPD)	OCPDs
	620.62(B)	OCPDs	Fine as is
	620.62(C)	OCPDs. And. Overcurrent Devices	Fine as is. And. OCPDs
	620.62	Overcurrent protective devices	OCPDs
	620.65. (X3)	Overcurrent Devices	OCPDs
12	Article 625		
	625.60(C). (X4)	Overcurrent Protection	Fine as is
12	Article 627		
	627.41	Overcurrent Protection	Fine as is
	627.41(A)	Overcurrent Protection	Fine as is

	627.41(B)	Overcurrent Devices	OCPDs
12	Article 630		
	630.12	Overcurrent Protection	Fine as is
	630.12	Overcurrent Device	OCPD
	630.12(A). (X2)	Overcurrent Protection	Fine as is
	630.12(A). (X5)	Overcurrent Device	OCPD
	630.13	Overcurrent Protection	Fine as is
	630.32	Overcurrent Protection	Fine as is
	630.32	Overcurrent Device	OCPD
12	Article 640		
	640.9(C)	Overcurrent Protection	Fine as is
	640.22	Overcurrent protection devices	OCPDs
	640.22	Overcurrent Devices	OCPDs
	640.43	Overcurrent protection devices	OCPDs
12	Article 645		
	645.27	Overcurrent protective devices, (OCPD)	OCPDs
	645.27	Overcurrent protective devices	OCPDs
12	Article 646		
	646.7. (X11)	Overcurrent Protection	Fine as is
12	Article 647		
	647.5	Overcurrent Protection	Fine as is
12	Article 650		
	650.9	Overcurrent Protection	Fine as is
	650.9	Overcurrent Device	OCPD
12	Article 660		
	660.7	Overcurrent Protection	Fine as is
	660.7(A)	Overcurrent protective devices	OCPDs
	660.7(B)	Overcurrent Devices	OCPDs
	660.7(B)	Overcurrent Protection	Fine as is
	660.9	Overcurrent Devices	OCPDs
12	Article 665		
	665.24	Overcurrent Protection	Fine as is
12	Article 668		
	668.4(C)(2)	Overcurrent Protection	Fine as is
	668.21	Overcurrent Protection	Fine as is

	668.21	Overcurrent Device	OCPD
12	Article 669		
	669.9	Overcurrent Protection	Fine as is
	669.9	be protected from Overcurrent	shall be provided with overcurrent protection
12	Article 670		
	670.1	Overcurrent Protection	Fine as is
	670.4(B). (X3)	Overcurrent Protection	Fine as is
	670.5. (X4)	Overcurrent Protection	Fine as is
	670.5(C). (X2)	Overcurrent protective device	OCPD
12	Article 685		
	685.10.	Overcurrent Devices	OCPDs

CMP-10 TG-4 Review of Overcurrent Language for the Articles under the purview of CMP-13

CMP	NEC Section (using First Draft of 2026 NEC)	Current Language	"New" Language
13	Article 100		
	Emerg. Power Supply Systems (EPSS)	overcurrent protection devices	overcurrent protective devices (OCPDs)
	Transfer-Switch B-C Emerg. Ltg.	branch-circuit overcurrent device	branch-circuit overcurrent protective device (OCPD)
13	Article 130		
	130.80(C)	overcurrent devices	OCPDs
	130.80(C)	branch-circuit overcurrent device	OCPD
13	Article 445		
	445.11	Overcurrent protective Relay	Fine as is
	445.12. Title	Overcurrent Protection	Fine as is
	445.12(A)	Overcurrent protective means	Overcurrent protection means
	445.12(B)	Overcurrent Protection	Fine as is
	445.12(B) (X2)	Overcurrent Device	OCPD
	445.12(C)	Overcurrent Device	OCPD
	445.12(D)	Overcurrent Devices	OCPDs
	445.12(E). (X3)	Overcurrent Devices	OCPDs
	445.13(A). (X2)	Overcurrent Protection	Fine as is
	445.13(B). Title	Overcurrent protection	Fine as is
	445.13(B).	Overcurrent protective device	OCPD
	445.13(B)	Overcurrent Relay	Fine as is
13	Article 455		
	455.7	Overcurrent Protection	Fine As Is
	455.7	protected from Overcurrent	shall be provided with overcurrent protection in accordance with
	455.7(A)	Overcurrent Protection	Fine As Is
	455.7(B)	Overcurrent Protection	Fine As Is
13	Article 480		
	480.4(B) IN.2	Overcurrent Protection	Fine As Is
	480.6. (X2)	Overcurrent Protection	Fine As Is
	480.7	Overcurrent Device	OCPD
13	Article 695		
	695.4(C)	Overcurrent protective devices	OCPDs
	695.4(H). Title	Overcurrent Device Selection	Overcurrent Protective Device Selection
	695.4(H)	Overcurrent Devices	OCPDs

	695.5	Overcurrent Device	OCPD
	695.5	Overcurrent protective devices	OCPDs
	695.5	Overcurrent Protection	Fine as is
	695.6	Overcurrent protective devices	OCPDs
	695.6	Overcurrent Devices	OCPD
	695.6	Overcurrent Protection	Fine as is
	695.7(A)(2)	Overcurrent Devices	OCPDs
	695.7	Overcurrent Protection	Fine as is
13	Article 700		
	700.4(F)(8)	Overcurrent protective devices, (OCPD)	OCPDs
	700.6(E)	Overcurrent protective device	OCPD
	700.10(B). (X6)	Overcurrent Protection	Fine as is
	700.10(B)(6)(b)(ii)	Overcurrent protective device	OCPD
	700.10(B)(6)(e)	Overcurrent protective devices	OCPDs
	Art. 700 Part VI	Overcurrent Protection	Fine as is
	700.30.	Branch-circuit overcurrent devices	OCPDs
	700.32(A)	Overcurrent protective devices, (OCPDs)	OCPDs
	700.32(A) In	Overcurrent Protection	Fine as is
	700.32(C)	Overcurrent Devices	OCPDs
13	Article 701		
	701.6(C)	Overcurrent protective device	OCPD
	701.10(B)(1). (X5)	Overcurrent Protection	Fine as is
	701.10(B)(1)	Overcurrent protective device	OCPD
	Art. 701. Part IV	Overcurrent Protection	OCPDs
	701.30.	Branch-Circuit Overcurrent devices	Branch-Circuit OCPDs
	701.32(A). (X2)	Overcurrent protective devices, OCPDs	OCPDs
	701.32(B). (X3)	OCPDs	Fine as is
	701.32(C). (X2)	OCPDs	Fine as is
	701.32(C)Ex	Overcurrent Devices	OCPDs
	701.32(C) In 2	OCPD and OCPDs	Fine as is
13	Article 702		
	702.5(C)	Overcurrent protective device	OCPD
13	Article 706		
	706.15(E)(1)	Overcurrent Device	OCPD
	706.30(B)	Overcurrent Devices	OCPDs

	706.31 Title	Overcurrent Protection	Fine as is
	706.31(A)	shall be protected at the source from overcurrent.	shall be provided with overcurrent protection at the source
	706.31(A)	shall be protected from overcurrent.	shall be provided with overcurrent protection
	706.31(A) In	Overcurrent Device	OCPD
	706.31(B). Title	Overcurrent Device	Overcurrent Protective Device
	706.31(B)	Overcurrent protective devices	OCPDs
	706.31(B)	Overcurrent devices	OCPDs
	706.31(C)	Overcurrent protective devices	OCPDs
	706.31(E)	Overcurrent Protection	Fine as is
	706.33(B)(2)	Overcurrent Device	OCPD
13	Article 708		
	708.10(B)	Overcurrent Protection	Fine as is
	708.24(E)	Overcurrent protective device	OCPD
	Art. 708. Part IV	Overcurrent Protection	Fine as is
	708.50.	Feeder- and Branch-circuit overcurrent devices	Feeder- and Branch-circuit OCPDs
	708.52(B)	Overcurrent Devices	OCPDs
	708.54(A)	Overcurrent protective devices, (OCPD)	OCPDs
	708.54(A). (B). (C)	OCPDs	Fine as is
	708.54	Overcurrent Devices	OCPDs

CMP-10 TG-4 Review of Overcurrent Language for the Articles under the purview of CMP-14

CMP	NEC Section (using First Draft of 2026 NEC)	Current Language	"New" Language
14	Article 500		
	500.30(A)(2)	Branch Circuit Overcurrent Protection	OCPD
	500.30.	Overcurrent Protection	Fine as is
14	Article 501		
	501.105(B)(5)	Overcurrent Protection	Fine as is
	501.125(B)(2)	Motor Overcurrent	Fine as is
14	Article 502		
	502.120(A)	Overcurrent Devices	OCPDs
	502.120(B)(1)	Overcurrent Devices	OCPDs
	502.125	Motor Overcurrent	Fine as is
14	Article 505		
	505.30(A)(2)	Branch Circuit Overcurrent Protection	OCPD
	505.30.	Overcurrent Protection	Fine as is
14	Article 506		
	506.30.	Branch Circuit Overcurrent Protection	OCPD
	506.30.	Overcurrent Protection	Fine as is

CMP-10 TG-4 Review of Overcurrent Language for the Articles under the purview of CMP-15

CMP	NEC Section (using First Draft of 2026 NEC)	Current Language	"New" Language
15	Article 100		
	Bull Switch	Overcurrent protection	Fine as is
15	Article 517		
	517.17(B)	Overcurrent protective devices	OCPDs
	517.31(G). (X5)	Overcurrent protective devices	OCPDs
	517.31(G)	Overcurrent	Fine as is
	517.33((C). (X5)	Overcurrent protective devices	OCPDs
	517.42(F)	Overcurrent protective devices	OCPDs
	517.42(F)	Overcurrent	Fine as is
	517.73	Overcurrent Protection	Fine as is
	517.73(A)	Overcurrent protective devices	OCPDs
	517.73(B)	Overcurrent protective devices	OCPDs
	517.73(B)	Overcurrent Protection	Fine as is
	517.74(B)	Overcurrent protective devices	OCPDs
	517.160(A)(2)	Overcurrent Protection	Fine as is
	517.160(A)(2)	Overcurrent protective device	OCPD
	517.160(A)(2)	be protected against Overcurrent	be provided with overcurrent protection
	517.160(A)(3)	Overcurrent protective devices	OCPDs
	517.160(B)(1)	Overcurrent protective devices	OCPDs
15	Article 518		
	518.7(A)(1)	Overcurrent Protection	Fine as is
	518.17(A)(1) and (2)	Overcurrent Devices	OCPDs
15	Article 520		
	520.9	Branch Circuit Overcurrent Device	OCPD
	520.21	Overcurrent protective devices	OCPDs
	520.25. (X3)	Overcurrent Protection	Fine as is
	520.26	Overcurrent protective devices	OCPD
	520.26. (X3)	Overcurrent Protection	Fine as is
	520.27. (X2)	Overcurrent Device	OCPD
	520.44-T	Overcurrent Devices	OCPD
	520.50(C)	Overcurrent Protection	Fine as is
	520.50.	Branch-circuit overcurrent protective device	OCPDs
	520.52	Overcurrent Protection	Fine as is

	520.53(A)	Overcurrent protective devices	OCPDs
	520.53(D)	Overcurrent Protection	Fine as is
	520.54	Overcurrent Devices	OCPDs
	520.54(D)	Overcurrent Device	OCPD
	520.54(D)(1) and (2)	Overcurrent protective devices	OCPD
	520.54(E)	Overcurrent protective device	OCPD
	520.54(E). (X4)	Overcurrent protection device	OCPD
	520.54(E)	Overcurrent Devices	OCPDs
	520.54(K)	Overcurrent Device	OCPD
	520.68	Overcurrent protective device	OCPD
	520.68(3)	Overcurrent Device	OCPD
	520.68(4)	Overcurrent protective device	OCPD
	520.68(6)	Overcurrent Devices	OCPDs
	520.68(C)	Overcurrent Protection	Fine as is
15	Article 522		
	522.10(A)(2). (X3)	Overcurrent Devices	OCPDs
	522.10(A)(2)	Overcurrent protective device	OCPD
	522.10(B). (X4)	Overcurrent Devices	OCPDs
	522.23. (X3)	Overcurrent Protection	Fine as is
15	Article 525		
	525.12	Overcurrent Device	OCPD
	525.23(B)	Overcurrent Device	OCPD
	525.23(C). (X2)	Overcurrent Protection	Fine as is
15	Article 530		
	530.9(A)	Branch-circuit overcurrent device	Branch-circuit OCPD
	530.10(C)	Overcurrent Protection	Fine as is
	530.23 and (A)	Overcurrent Protection	Fine as is
	530.23(B)	Overcurrent protective devices	OCPDs
	530.23(D)	Overcurrent Protection	Fine as is
	530.42	Overcurrent Protection	Fine as is
15	Article 540		
	540.11(B)	Overcurrent Devices	OCPDs

CMP-10 TG-4 Review of Overcurrent Language for the Articles under the purview of CMP-16

CMP	NEC Section (using First Draft of 2026 NEC)	Current Language	"New" Language
16	Article 830		
	830.15. (X4)	Overcurrent Protection	Fine as is

CMP-10 TG-4 Review of Overcurrent Language for the Articles under the purview of CMP-17

CMP	NEC Section (using First Draft of 2026 NEC)	Current Language	"New" Language
17	Article 422		
	422.5(C)	Branch-circuit overcurrent protective device	Branch-Circuit OCPD
	422.11. Title	Overcurrent Protection	Fine as is
	422.11	protected against overcurrent	shall be provided with overcurrent protection
	422.11(A)	Overcurrent Protection	Fine as is
	422.11(A)	Branch-circuit overcurrent protective device	Branch-Circuit OCPD
	422.11(B)	Overcurrent Protection	OCPDs
	422.11(C)	Overcurrent Protection	OCPDs
	422.11(D)	Overcurrent protective devices	OCPDs
	422.11(E)	Overcurrent Protection	Fine as is
	422.11(E)(1)	Overcurrent Protection	Fine as is
	422.11(E)(2)	Overcurrent Protection	Fine as is
	422.11(E)(3)	Overcurrent Protection	OCPD
	422.11(E)(3)	Overcurrent Device	OCPD
	422.11(F)(1)	Supplementary Overcurrent Protective Devices	Supplementary OCPDs
	422.11(F)(1)	Overcurrent Protective Devices	OCPDs
	422.11(G)	Overcurrent Protective Devices	OCPDs
	422.13	Overcurrent Protection	Fine as is
	422.31(A)	Branch-circuit overcurrent protective device	Branch-Circuit OCPD
	422.60(A)	Overcurrent Protection	Fine as is
	422.62(B)(1). (X2)	Overcurrent protective device	OCPD
17	Article 424		
	424.19	Supplementary Overcurrent Protective Devices	Supplementary OCPDs
	424.19(A)	Supplementary Overcurrent Protection	Fine as is
	424.19(A)	Supplementary Overcurrent Protection	Fine as is
	424.19(A)	Supplementary Overcurrent Protective Device(s)	Supplementary OCPDs
	424.19(B)	Supplementary Overcurrent Protection	Fine as is
	424.22	Overcurrent Protection	Fine as is
	424.22(A)	Overcurrent Protection	Fine as is
	424.22(A)	protected against overcurrent	"..shall be permitted to have overcurrent protection.."
	424.22(B)	Supplementary Overcurrent Protective Device	Supplementary OCPD
	424.22(C). Title	Overcurrent Protective Devices	Fine as is
	424.22(C)	Supplementary Overcurrent Protective Devices	Supplementary OCPDs

	424.22(C)	Overcurrent Protection	Fine as is
	424.22(C)	Supplementary Overcurrent Protection	Fine as is
	424.22(D) (X2)	Supplementary Overcurrent Protective Devices	Supplementary OCPDs
	424.22(E). (X3)	Supplementary Overcurrent Protective Devices	Supplementary OCPDs
	424.72	Overcurrent Protection	Fine as is
	424.72(A)	Overcurrent protective device	OCPD
	424.72(B)	Overcurrent protective device	OCPD
	424.72(C). Title	Supplementary Overcurrent Protective Devices	Fine as is
	424.72(C)	Supplementary Overcurrent Protective Devices	Supplementary OCPDs
	424.72(C)	Overcurrent Protection	Fine as is
	424.72(D). Title	Supplementary Overcurrent Protective Devices	Fine as is
	424.72(D).	Supplementary Overcurrent Protective Devices	Supplementary OCPDs
	424.72(D)	Overcurrent protective device	OCPD
	424.72(E)	Supplementary Overcurrent Protective Devices. (X3)	Supplementary OCPDs
	424.82	Overcurrent protective devices	OCPDs
17	Article 425		
	425.19	Supplementary Overcurrent Protective Devices	Supplementary OCPDs
	425.19(A). (X2)	Supplementary Overcurrent Protection	Fine as is
	425.19(A)	Supplementary Overcurrent Protective Devices	Supplementary OCPDs
	425.19(B)	Supplementary Overcurrent Protection	Fine as is
	425.22. Title	Overcurrent Protection	Fine as is
	425.22(A)	Overcurrent Protection	Fine as is
	425.22(A)	protected against overcurrent	"..shall be permitted to have overcurrent protection.."
	425.22(B)	Supplementary Overcurrent Protective Device	Supplementary OCPD
	425.22(C). Title	Overcurrent Protective Devices	Fine as is
	425.22(C)	Supplementary Overcurrent Protective Devices	Supplementary OCPDs
	425.22(C). (X2)	Supplementary Overcurrent Protection	Fine as is
	425.22(D). Title	Supplementary Overcurrent Protective Devices	Fine as is
	425.22(D). (X2)	Supplementary Overcurrent Protective Devices	Supplementary OCPDs
	425.22(E) (X3)	Supplementary Overcurrent Protective Devices	Supplementary OCPDs
	425.72	Overcurrent Protection	Fine as is
	425.72(A)	Overcurrent protective device	OCPD
	425.72(B)	Overcurrent protective device	OCPD
	425.72(C). Title	Supplementary Overcurrent Protective Devices	Fine as is
	425.72(C)	Supplementary Overcurrent Protective Devices	Supplementary OCPDs

	425.72(C)	Overcurrent Protection	Fine as is
	425.72(D)	Overcurrent protection	Fine as is
	425.72(E). Title	Supplementary Overcurrent Protective Devices	Fine as is
	425.72(E)	Supplementary Overcurrent Protective Devices	Supplementary OCPDs
	425.72(E)	Overcurrent Protective Devices	OCPD
	425.72(F). (X3)	Supplementary Overcurrent Protective Devices	Supplementary OCPDs
	425.82	Overcurrent protective devices	OCPDs
17	Article 427		
	427.57	Overcurrent Protection	Fine as is
	427.57	considered protected against Overcurrent	considered to have overcurrent protection
17	Article 680		
	680.10.(A)& (B)(2)	Overcurrent protective devices	OCPDs
	680.23(F)(2)	Overcurrent Protection	Fine as is

CMP-10 TG-4 Review of Overcurrent Language for the Articles under the purview of CMP-18

CMP	NEC Section (using First Draft of 2026 NEC)	Current Language	"New" Language
18	Article 393		
	393.45. Title	Overcurrent Protection	Overcurrent Protection
	393.45(A)	Overcurrent Protection	Fine as is
18	Article 406		
	406.46(F)	Overcurrent Device	OCPD
18	Article 410		
	410.59(A)	Branch-circuit overcurrent devices	Branch-Circuit OCPD
	410.153	Overcurrent Protection	Fine as is
18	Article 600		
	600.41	Overcurrent	CMP to Review



Public Comment No. 2046-NFPA 70-2024 [Global Input]

I've just been through Section No. 625 and 627 on electric vehicle transfer systems.

Much of this code duplicates what's already in the various international standards regulating listed EVSE. Doing so in the NEC creates a different standard for the USA compared to the global market, potentially exposing USA consumers to higher costs. If the NEC coverage ended at the branch circuit outlet or receptacle, the national standards can take the heavy lifting from there.

What we could do in the USA is a better job of keeping out unlisted and counterfeit EVSE, or at least keeping licenced persons from installing them.

There are similar instances in the code such as "Section 650 Pipe Organs". It's totally appropriate for wiring methods to be in the NEC, but there's very little electrically special about a pipe organ. Same general issue: where does the branch circuit end, and the (here unregulated) equipment begin?

Statement of Problem and Substantiation for Public Comment

Shorter code.
More ability to focus on the core of the NEC: circuits and branches.

Related Item

• Section 625 and 627 • First Revision No. 9039-NFPA 70-2024 [Global Input]

Submitter Information Verification

Submitter Full Name: Bryce Nesbitt
Organization: Obviously Inspects
Street Address:
City:
State:
Zip:
Submittal Date: Wed Aug 28 16:46:34 EDT 2024
Committee: NEC-P12



Public Comment No. 1191-NFPA 70-2024 [Definition: Electric Self-Propelled Vehicle (ESV).]

Electric Self-Propelled or Unpropelled Vehicle (ESV).

A vehicle or marine vessel, other than an EV, such as farm equipment, boats, trailers, carts, mobile household appliances, aircraft, and golf carts, unpropelled or primarily powered by an electric motor that draws current from a rechargeable storage battery, fuel cell, photovoltaic array, or other source of electric current. (627) (CMP-12)

Statement of Problem and Substantiation for Public Comment

Merriam-Webster defines a vehicle as "a means of carrying or transporting something."

However, the current language in the National Electric Code (NEC) excludes unpropelled vehicles, such as solar and battery trailers and carts, as well as portable electricity-generating household appliances. This exclusion lacks a scientifically sound rationale.

Unpropelled vehicles like carts, trailers, and cord-connected electricity-generating household appliances should be considered within the NEC's scope as Electric Vehicles (EVs). Without a compliant pathway through codes and standards, the market will likely continue to see the rise of "guerrilla" style solar and storage battery products. These products, thriving in today's dynamic online marketplace, set the pace outside established regulatory frameworks.

By clarifying the regulatory grey areas for mobile, grid-interconnected plug-in equipment, we can establish an unambiguous framework that significantly enhances safety in contrast to the the current "guerrilla style" installations.

Including all "plug-in" vehicles, portable devices, and equipment within the NEC will allow us to legally support a safe and smart, interconnected future electric grid by fully including all bidirectional Distributed Energy Resources (DERs). This inclusion would enable lower- and moderate-income prosumers to participate in the electricity market, creating valid economic opportunities for these underserved communities. Additionally, it would incentivize manufacturers to certify their products, thereby improving consumer protection.

Related Item

- Global FR 9093

Submitter Information Verification

Submitter Full Name: Achim Ginsberg-Klemmt

Organization: GismoPower LLC

Affiliation: GismoPower LLC

Street Address:

City:

State:

Zip:

Submittal Date: Fri Aug 16 22:41:39 EDT 2024

Committee: NEC-P12



Public Comment No. 1224-NFPA 70-2024 [Definition: Electric Self-Propelled Vehicle Power Export Eq...]

~~Electric Self-Propelled Vehicle~~ Vehicle Power Export Equipment (ESVPE EVPE)

The equipment, including the outlet on the electric self-propelled or unpropelled vehicle or household appliance (ESV), that is used to provide electrical power at voltages greater than or equal to 30 Vac or 60 Vdc to loads external to the ESV, using the vehicle as the source of supply. (627) (CMP-12)

Informational Note: Electric self-propelled vehicle power export equipment and electric self-propelled vehicle supply equipment or wireless power transfer equipment are sometimes contained in one piece of equipment, sometimes referred to as a bidirectional electric self-propelled vehicle supply equipment (ESVSE EVSE) or bidirectional wireless power transfer equipment (WPTE).

Statement of Problem and Substantiation for Public Comment

Merriam-Webster defines a vehicle as "a means of carrying or transporting something."

However, the current language in the National Electric Code (NEC) excludes unpropelled vehicles, such as solar and battery trailers and carts, as well as portable electricity-generating household appliances. This exclusion lacks a scientifically sound rationale.

Unpropelled vehicles like carts, trailers, and cord-connected electricity-generating household appliances should be considered within the NEC's scope as Electric Vehicles (EVs). Without a compliant pathway through codes and standards, the market will likely continue to see the rise of "guerrilla" style solar and storage battery products. These products, thriving in today's dynamic online marketplace, set the pace outside established regulatory frameworks.

By clarifying the regulatory grey areas for mobile, grid-interconnected plug-in equipment, we can establish an unambiguous framework that significantly enhances safety in contrast to the the current "guerrilla style" installations.

Including all "plug-in" vehicles, portable devices, and equipment within the NEC will allow us to legally support a safe and smart, interconnected future electric grid by fully including all bidirectional Distributed Energy Resources (DERs). This inclusion would enable lower- and moderate-income prosumers to participate in the electricity market, creating valid economic opportunities for these underserved communities. Additionally, it would incentivize manufacturers to certify their products, thereby improving consumer protection.

Related Item

- Global FR 9093

Submitter Information Verification

Submitter Full Name: Achim Ginsberg-Klemmt

Organization: GismoPower LLC

Affiliation: Gismo Power LLC

Street Address:

City:

State:

Zip:

Submittal Date: Sat Aug 17 22:03:41 EDT 2024

Committee: NEC-P12



Public Comment No. 164-NFPA 70-2024 [Definition: Electric Self-Propelled Vehicle Supply Equipmen...]

Electric Self-Propelled Vehicle Supply Equipment (ESVSE).

Equipment for plug-in charging, including the ungrounded, grounded, and equipment grounding conductors, and the electric self-propelled vehicle connectors, attachment plugs, personnel protection system, and all other fittings, devices, power outlets, or apparatus installed specifically for the purpose of transferring energy between the premises wiring and the electric self-propelled vehicle. (627) (CMP-12)

Informational Note: Electric self-propelled vehicle power export equipment and electric self-propelled vehicle supply equipment or wireless power transfer equipment (WPTE) are sometimes contained in one piece of equipment, sometimes referred to as a bidirectional ESVSE or bidirectional WPTE.

Statement of Problem and Substantiation for Public Comment

A Task Group for Article 627 and associated definitions was convened by CMP 12 and the TG realized that this definition was missing "self-propelled" in the last part of the definition to make it a properly defined term.

Related Item

• FR 8480 • FR 9039

Submitter Information Verification

Submitter Full Name: Richard Shawbell

Organization: Florida East Coast Electrical

Street Address:

City:

State:

Zip:

Submittal Date: Tue Jul 23 11:19:59 EDT 2024

Committee: NEC-P12



Public Comment No. 487-NFPA 70-2024 [Definition: Electric Self-Propelled Vehicle Supply Equipmen...]

Electric Self-Propelled Vehicle Supply Equipment (ESVSE).

Equipment for plug-in charging, including the ungrounded, grounded, and equipment grounding conductors, and the electric self-propelled vehicle connectors, attachment plugs, personnel protection system, and all other fittings, devices, power outlets, or apparatus installed specifically for the purpose of transferring energy between the premises wiring and the electric vehicle. (627) (CMP-12)

Informational Note: Electric self-propelled vehicle power export equipment and electric self-propelled vehicle supply equipment or wireless power transfer equipment (WPTE) are sometimes contained in one piece of equipment, sometimes referred to as a bidirectional ESVSE or bidirectional WPTE.

Additional Proposed Changes

<u>File Name</u>	<u>Description</u>	<u>Approved</u>
CN_134.pdf		

Statement of Problem and Substantiation for Public Comment

NOTE: The following CC Note No. 134 appeared in the First Draft Report on First Revision No. 8480.

The Correlating Committee directs CMP 12 to confirm the intended last two words of this definition. The text in the first revision included "electric vehicle" as opposed to "electric self-propelled vehicle", which doesn't correlate with the inclusion of the new term "electric self-propelled vehicle".

The use of "electric vehicle" in this definition adds confusion to the already confusing topic of two articles with similar content and two very similar terms.

Related Item

- First Revision No. 8480

Submitter Information Verification

Submitter Full Name: CC Notes

Organization: NEC Correlating Committee

Street Address:

City:

State:

Zip:

Submittal Date: Tue Jul 30 19:48:33 EDT 2024

Committee: NEC-P12



Correlating Committee Note No. 134-NFPA 70-2024 [Definition: Electric Self-Propelled Vehicle Supply Equipmen...]

Submitter Information Verification

Committee: NEC-AAC

Submittal Date: Wed May 08 15:42:42 EDT 2024

Committee Statement

Committee Statement: The Correlating Committee directs CMP 12 to confirm the intended last two words of this definition. The text in the first revision included “electric vehicle” as opposed to “electric self-propelled vehicle”, which doesn’t correlate with the inclusion of the new term “electric self-propelled vehicle”.

The use of “electric vehicle” in this definition adds confusion to the already confusing topic of two articles with similar content and two very similar terms.

[First Revision No. 8480-NFPA 70-2024 \[New Definition after Definition: Electric Power Production ...\]](#)

Ballot Results

✓ **This item has passed ballot**

12 Eligible Voters

1 Not Returned

11 Affirmative All

0 Affirmative with Comments

0 Negative with Comments

0 Abstention

Not Returned

McDaniel, Roger D.

Affirmative All

Ayer, Lawrence S.

Bowmer, Trevor N.

Hickman, Palmer L.

Holub, Richard A.

Jackson, Peter D.

Kendall, David H.

Manche, Alan

Osborne, Robert D.

Porter, Christine T.

Schultheis, Timothy James

Williams, David A.



Public Comment No. 1225-NFPA 70-2024 [Definition: Electric Vehicle (EV).]

Electric Vehicle (EV).

~~An automotive-type vehicle for on-road use, such as passenger automobiles, buses, trucks, vans, neighborhood electric vehicles, and electric motorcycles. A vehicle, defined using the Merriam-Webster definition as "a means of carrying or transporting something", unpropelled or primarily powered by an electric motor that draws current from a rechargeable storage battery, fuel cell, photovoltaic array, or other source of electric current. Plug-in hybrid electric vehicles (PHEV) are electric vehicles having a second source of motive power. (CMP-12)~~

~~Informational Note: Off-road, self-propelled electric mobile machines, such as industrial trucks, hoists, lifts, transports, golf carts, airline ground support equipment, tractors, and boats are not considered electric vehicles.~~

Statement of Problem and Substantiation for Public Comment

Merriam-Webster defines a vehicle as "a means of carrying or transporting something."

However, the current language in the National Electric Code (NEC) excludes unpropelled vehicles, such as solar and battery trailers and carts, as well as portable electricity-generating household appliances. This exclusion lacks a scientifically sound rationale.

Unpropelled vehicles like carts, trailers, and cord-connected electricity-generating household appliances should be considered within the NEC's scope as Electric Vehicles (EVs). Without a compliant pathway through codes and standards, the market will likely continue to see the rise of "guerrilla" style solar and storage battery products. These products, thriving in today's dynamic online marketplace, set the pace outside established regulatory frameworks.

By clarifying the regulatory grey areas for mobile, grid-interconnected plug-in equipment, we can establish an unambiguous framework that significantly enhances safety in contrast to the the current "guerrilla style" installations.

Including all "plug-in" vehicles, portable devices, and equipment within the NEC will allow us to legally support a safe and smart, interconnected future electric grid by fully including all bidirectional Distributed Energy Resources (DERs). This inclusion would enable lower- and moderate-income prosumers to participate in the electricity market, creating valid economic opportunities for these underserved communities. Additionally, it would incentivize manufacturers to certify their products, thereby improving consumer protection.

Related Item

- Global FR 9093

Submitter Information Verification

Submitter Full Name: Achim Ginsberg-Klemmt

Organization: GismoPower LLC

Affiliation: GismoPower LLC

Street Address:

City:

State:

Zip:

Submittal Date: Sat Aug 17 22:10:35 EDT 2024

Committee: NEC-P12



Public Comment No. 1966-NFPA 70-2024 [Definition: Electric Vehicle Power Export Equipment (EVPE).]

Electric Vehicle Power Export Equipment (EVPE).

The equipment, including the outlet on the electric vehicle or deutilization equipment , that is used to provide electrical power at voltages greater than or equal to 30 Vac or 60 Vdc to loads external to the electric vehicle or deutilization equipment , using the electric vehicle or deutilization equipment as the source of supply. (625) (CMP-12)

Informational Note: Electric vehicle power export equipment and electric vehicle supply equipment or wireless power transfer equipment are sometimes contained in one piece of equipment, sometimes referred to as a bidirectional electric vehicle supply equipment (EVSE) or bidirectional wireless power transfer equipment (WPTE).

Statement of Problem and Substantiation for Public Comment

The fact of the matter is that the NFPA 70, National Electric Code, is a document to prevent Electrical Fires, and the greatest risk of Electrical Fires in the era defined by this electric code is that of anthropogenic climate change. The changes to chapter 625, while are much needed and welcome in enabling vehicle to grid technology, do not go nearly far enough to prevent the imminent fire risk posed, both by the direct results of anthropogenic climate change, but also by the response to that risk by individual people if left uncontrolled.

Chapter 625 attempts to establish and describe vehicle to grid but does so narrowing it into the technology limitations of our time, meanwhile, this is an electric code which will need to serve the fire protection needs of the era between 2026 and 2029, the apex of the battle with climate change. The actual technology which should be enshrined in the National Electric Code should be the ability for safe, boutique, plug and play, prosumer generation technology, which should be technology agnostic, should not be narrowed to a vehicle, and should be backwards compatible to the current built electrical environment and not require expensive upgrades to existing electrical systems. Today we can only conceive of an era in which these devices are vehicles, and that the currents and voltages required in essence require a proto-service entrance, but we are on the precipice of changes such as solid-state batteries which could dramatically shrink the size of equipment which could provide useful power to the grid, and an era in which the efficiency of devices on the market is increasing at such a rate that it is conceivable that by 2029, a cell phone could power all the lights of an entire office.

This is what I attempt to do in my changes, which should be viewed as a set, by pulling the electric vehicle out of these standards to enable future technologies such as cell phone to grid, balcony solar, balcony wind, oven to grid, and gains to grid.

Thank you for your time,

Amethyst O'Connell

(My comments are mine as an individual and should not be misconstrued as representing my companies or my university and it's affiliates.)

Related Public Comments for This Document

Related Comment

[Public Comment No. 1959-NFPA 70-2024 \[New Definition after Definition: Deploy_\(Deployed\),\]](#)

Relationship

definition of deutilization equipment

Related Item

• [First Revision No. 8260-NFPA 70-2024 \[Section No. 625.22 \]](#)

Submitter Information Verification

Submitter Full Name: Amethyst O'Connell

Organization: [Not Specified]

Street Address:

City:

State:

Zip:

Submittal Date: Wed Aug 28 13:15:28 EDT 2024

Committee: NEC-P12



Public Comment No. 2033-NFPA 70-2024 [Definition: Fastened-in-Place (as applied to electric vehic...]

~~Fastened-in-Place (as applied to electric vehicle power transfer systems and electric self-propelled vehicle power transfer systems): Hand Fastened~~

Mounting means of equipment in which the fastening means are specifically designed to permit removal without the use of a tool.- (CMP-12) _

Additional Proposed Changes

<u>File Name</u>	<u>Description</u>	<u>Approved</u>
.1724876878581 Substantiation_for_Comments_for_Fixed-Fastened.docx	Substantiation	

Statement of Problem and Substantiation for Public Comment

Public inputs regarding the CMP-12 definitions for "Fixed-in-place" and "Fastened-in-place" by two prominent Code trainers and commentators (PI-2460 by Mike Holt and PI-4230 and 4231 by Jeffrey Simpson) clearly display the confusion that exists in the public with these definitions (their Public Inputs were resolved due to their errant substantiation based on their misunderstanding). Though technically correct as is, these minor changes will simplify and clarify the Code by modifying the one term and using a consistent phrase already in use throughout the Code.

Background

"Fastened in place" is used in the Code 58 times as follows"

Chapter 1: In addition to the CMP-12 definition it is used in the "Appliance" definition.

Chapter 2: 17 times, implies fixed and specifies (fixed) in a few places

Chapter 3: 19 times, prefaced with "securely" to make the phrase "securely fastened in place"; 20 times overall

Chapter 4: 1 time prefaced with "securely"; 2 times overall

Chapter 5: 2 times prefaced with "securely"; 6 times overall

Chapter 6: 5 times prefaced with "securely"; 10 times overall; the other 5 times in 625 (see below)

Chapter 8: 1 time prefaced with "securely"

"Fixed in place" is used only 1 time in the CMP-12 portion of the Code and two other times in total – 1 in Chapter 5 and 1 in Chapter 7. A term that is only used once does not require a definition since that same definition can be written in place of the term at the point of use. However, it is proposed to use the same phrase that is used 28 times in the Code to mean the same thing (securely fastened in place).

Related Public Comments for This Document

<u>Related Comment</u>	<u>Relationship</u>
Public Comment No. 2040-NFPA 70-2024 [Definition: Fixed-in-Place (as applied to electric vehicle ...]	
Public Comment No. 2045-NFPA 70-2024 [Section No. 625.17]	
Public Comment No. 2048-NFPA 70-2024 [Sections 625.44(B), 625.44(C)]	
Public Comment No. 2040-NFPA 70-2024 [Definition: Fixed-in-Place (as applied to electric vehicle ...]	
Public Comment No. 2045-NFPA 70-2024 [Section No. 625.17]	
Public Comment No. 2048-NFPA 70-2024 [Sections 625.44(B), 625.44(C)]	

Related Item

- PI-2460, 4230, 4231

Submitter Information Verification

Submitter Full Name: Karl Cunningham

Organization: Self Employed

Street Address:

City:

State:

Zip:

Submittal Date: Wed Aug 28 16:26:16 EDT 2024

Committee: NEC-P12

Substantiation for NEC 70 Comments for Fixed-in-place, Fastened-in-place

Public inputs regarding the CMP-12 definitions for “Fixed-in-place” and “Fastened-in-place” by two prominent Code trainers and commentators (PI-2460 by Mike Holt and PI-4230 and 4231 by Jeffrey Simpson) clearly display the confusion that exists in the public with these definitions (their Public Inputs were resolved due to their errant substantiation based on their misunderstanding). Though technically correct as is, these minor changes will simplify and clarify the Code by modifying the one term and using a consistent phrase already in use throughout the Code.

Background

“Fastened in place” is used in the Code 58 times as follows”

Chapter 1: In addition to the CMP-12 definition it is used in the “Appliance” definition.

Chapter 2: 17 times, implies fixed and specifies (fixed) in a few places

Chapter 3: 19 times, prefaced with “securely” to make the phrase “securely fastened in place”; 20 times overall

Chapter 4: 1 time prefaced with “securely”; 2 times overall

Chapter 5: 2 times prefaced with “securely”; 6 times overall

Chapter 6: 5 times prefaced with “securely”; 10 times overall; the other 5 times in 625 (see below)

Chapter 8: 1 time prefaced with “securely”

“Fixed in place” is used only 1 time in the CMP-12 portion of the Code and two other times in total – 1 in Chapter 5 and 1 in Chapter 7. A term that is only used once does not require a definition since that same definition can be written in place of the term at the point of use. However, it is proposed to use the same phrase that is used 28 times in the Code to mean the same thing (securely fastened in place).

Proposal to delete the highlighted/strikethrough words and add in the **green** words as follows:

Fixed-in-Place.

Mounting means of equipment using fasteners that require a tool for removal. (625) (CMP-12)

Delete

Fastened-in-Place.

Mounting means of equipment in which the fastening means are specifically designed to permit removal without the use of a tool. (625) (CMP-12)

Change definition to “Hand Fastened”

625.17(A) Power-Supply Cord.

The cable for cord-connected electric vehicle supply equipment (EVSE) shall comply with all of the following:

1. (1)

Be any of the types specified in [625.17\(B\)\(1\)](#) or hard service cord, junior hard service cord, or portable power cable types in accordance with [Table 400.4](#). Hard service cord, junior hard service cord, or portable power cable types shall be listed, as applicable, for exposure to oil and damp and wet locations.

2. (2)

Have an ampacity as specified in [Table 400.5\(A\)\(1\)](#) or, for 8 AWG and larger, in the 60°C (140°F) columns of [Table 400.5\(A\)\(2\)](#).

3. (3)

Have an overall length as specified in either of the following:

1. a.

When the interrupting device of the personnel protection system specified in [625.22](#) is located within the enclosure of the supply equipment or charging system, the power-supply cord shall be not more than the length indicated in (i) or (ii):

1. (i)

For portable equipment in accordance with [625.44\(A\)](#), the power-supply cord shall be not more than 300 mm (12 in.) long.

2. (ii)

For ~~fastened-in-place~~ hand fastened equipment in accordance with [625.44\(B\)](#), the power-supply cord shall be not more than 1.8 m (6 ft) long and the equipment shall be installed at a height that prevents the power-supply cord from contacting the floor when it is connected to the proper receptacle.

2. b.

When the interrupting device of the personnel protection system specified in [625.22](#) is located at the attachment plug, or within the first 300 mm (12 in.) of the power-supply cord, the overall cord length shall be not greater than 4.6 m (15 ft).

625.17(B) Output Cable to Electric Vehicles.

The output cable to electric vehicles shall be one of the following:

1. (1)

Listed Type EV, EVJ, EVE, EVJE, EVT, or EVJT flexible cable as specified in [Table 400.4](#)

2. (2)

An integral part of listed electric vehicle supply equipment
Informational Note No. 1: See UL 2594-2016, *Standard for Electric Vehicle Supply Equipment*, for information on conductive electric vehicle supply equipment.

Informational Note No. 2: See UL 2202-2009, *Standard for Electric Vehicle (EV) Charging System Equipment*, for information on conductive electric vehicle charging equipment.

625.17(C) Overall Cord and Cable Length.

The overall usable length shall not exceed 7.5 m (25 ft) unless equipped with a cable management system that is part of the listed electric vehicle supply equipment.

625.17(C)(1) Portable Equipment.

For portable EVSE, the cord-exposed usable length shall be measured from the face of the attachment plug to the face of the electric vehicle connector.

625.17(C)(2) Fastened-in-Place. Hand Fastened

Where the EVSE is fastened-in-place, hand fastened the usable length of the output cable to the electric vehicle shall be measured from the cable exit of the electric vehicle supply equipment to the face of the electric vehicle connector.

Where the wireless power transfer equipment (WPTE) is fastened-in-place, the output cable to the primary pad shall be measured from the cable exit of the control box to the cable inlet at the primary pad.

625.44(B) Fastened-in-Place Hand Fastened Equipment.

Equipment that is fastened-in-place shall be connected to the premises wiring system by one of the following methods:

1. (1)

A nonlocking, 2-pole, 3-wire grounding-type receptacle outlet rated 125 volts or 250 volts, single phase, up to 50 amperes

2. (2)

A nonlocking, 3-pole, 4-wire grounding-type receptacle outlet rated 250 volts, three phase, up to 50 amperes

3. (3)

A nonlocking, 3-pole, 4-wire grounding-type receptacle outlet rated 125/250 volts, single phase, 30, 50, or 60 amperes

4. (4)

A nonlocking, 2-pole, 3-wire grounding-type receptacle outlet rated 60 volts dc maximum, 15 or 20 amperes

625.44(C) Fixed-in-Place Securely Fastened in Place Equipment.

All other EVSE and WPTE shall be permanently wired and fixed-in-place securely fastened in place to the supporting surface.



Public Comment No. 300-NFPA 70-2024 [Definition: Fastened-in-Place (as applied to electric vehic...]

~~Fastened-in-Place (as applied to electric vehicle power transfer systems and electric self-propelled vehicle power transfer systems).~~

Mounting means of equipment in which the fastening means are specifically designed to permit removal without the use of a tool. (625)(CMP-12)

Statement of Problem and Substantiation for Public Comment

The committee should combine the contents of Articles 625 and 627 back into a single article, using Parts as required, so that this definition can apply to a single article. This option to distinguish the term with a modifier in this manner is only allowed where there are multiple definitions for a term (NEC® Style Manual 2.1.2.7).

Related Item

- FCR-363

Submitter Information Verification

Submitter Full Name: Richard Holub

Organization: The DuPont Company, Inc.

Street Address:

City:

State:

Zip:

Submittal Date: Mon Jul 29 08:50:29 EDT 2024

Committee: NEC-P12



Public Comment No. 2040-NFPA 70-2024 [Definition: Fixed-in-Place (as applied to electric vehicle ...)

~~Fixed-in-Place (as applied to electric vehicle power transfer systems and electric self-propelled vehicle power transfer systems):~~
Mounting means of equipment using fasteners that require a tool for removal. (CMP-12)

Additional Proposed Changes

<u>File Name</u>	<u>Description</u>	<u>Approved</u>
Substantion_for_Comments_for_Fixed-Fastened.docx	Substantiation and other impacts	

Statement of Problem and Substantiation for Public Comment

Public inputs regarding the CMP-12 definitions for "Fixed-in-place" and "Fastened-in-place" by two prominent Code trainers and commentators (PI-2460 by Mike Holt and PI-4230 and 4231 by Jeffrey Simpson) clearly display the confusion that exists in the public with these definitions (their Public Inputs were resolved due to their errant substantiation based on their misunderstanding). Though technically correct as is, these minor changes will simplify and clarify the Code by modifying the one term and using a consistent phrase already in use throughout the Code.

Background

"Fastened in place" is used in the Code 58 times as follows"

Chapter 1: In addition to the CMP-12 definition it is used in the "Appliance" definition.

Chapter 2: 17 times, implies fixed and specifies (fixed) in a few places

Chapter 3: 19 times, prefaced with "securely" to make the phrase "securely fastened in place"; 20 times overall

Chapter 4: 1 time prefaced with "securely"; 2 times overall

Chapter 5: 2 times prefaced with "securely"; 6 times overall

Chapter 6: 5 times prefaced with "securely"; 10 times overall; the other 5 times in 625 (see below)

Chapter 8: 1 time prefaced with "securely"

This use of the phrase "securely fastened in place" throughout the code is essentially the definition article 625 has applied to fixed-in-place."

"Fixed in place" is used only 1 time in the CMP-12 portion of the Code and two other times in total – 1 in Chapter 5 and 1 in Chapter 7. A term that is only used once does not require a definition since that same definition can be written in place of the term at the point of use. However, it is proposed to use the same phrase that is used 28 times in the Code to mean the same thing (securely fastened in place).

Related Public Comments for This Document

<u>Related Comment</u>	<u>Relationship</u>
Public Comment No. 2033-NFPA 70-2024 [Definition: Fastened-in-Place (as applied to electric vehic...]	
Public Comment No. 2045-NFPA 70-2024 [Section No. 625.17]	
Public Comment No. 2048-NFPA 70-2024 [Sections 625.44(B), 625.44(C)]	
Public Comment No. 2033-NFPA 70-2024 [Definition: Fastened-in-Place (as applied to electric vehic...]	
Public Comment No. 2045-NFPA 70-2024 [Section No. 625.17]	
Public Comment No. 2048-NFPA 70-2024 [Sections 625.44(B), 625.44(C)]	

Related Item

- PI-2460, 4230, 4231

Submitter Information Verification

Submitter Full Name: Karl Cunningham
Organization: Self Employed
Street Address:
City:
State:
Zip:
Submittal Date: Wed Aug 28 16:36:41 EDT 2024
Committee: NEC-P12

Substantiation for NEC 70 Comments for Fixed-in-place, Fastened-in-place

Public inputs regarding the CMP-12 definitions for “Fixed-in-place” and “Fastened-in-place” by two prominent Code trainers and commentators (PI-2460 by Mike Holt and PI-4230 and 4231 by Jeffrey Simpson) clearly display the confusion that exists in the public with these definitions (their Public Inputs were resolved due to their errant substantiation based on their misunderstanding). Though technically correct as is, these minor changes will simplify and clarify the Code by modifying the one term and using a consistent phrase already in use throughout the Code.

Background

“Fastened in place” is used in the Code 58 times as follows”

Chapter 1: In addition to the CMP-12 definition it is used in the “Appliance” definition.

Chapter 2: 17 times, implies fixed and specifies (fixed) in a few places

Chapter 3: 19 times, prefaced with “securely” to make the phrase “securely fastened in place”; 20 times overall

Chapter 4: 1 time prefaced with “securely”; 2 times overall

Chapter 5: 2 times prefaced with “securely”; 6 times overall

Chapter 6: 5 times prefaced with “securely”; 10 times overall; the other 5 times in 625 (see below)

Chapter 8: 1 time prefaced with “securely”

“Fixed in place” is used only 1 time in the CMP-12 portion of the Code and two other times in total – 1 in Chapter 5 and 1 in Chapter 7. A term that is only used once does not require a definition since that same definition can be written in place of the term at the point of use. However, it is proposed to use the same phrase that is used 28 times in the Code to mean the same thing (securely fastened in place).

Proposal to delete the highlighted/strikethrough words and add in the **green** words as follows:

Fixed-in-Place.

Mounting means of equipment using fasteners that require a tool for removal. (625) (CMP-12)

Delete

Fastened-in-Place.

Mounting means of equipment in which the fastening means are specifically designed to permit removal without the use of a tool. (625) (CMP-12)

Change definition to “Hand Fastened”

625.17(A) Power-Supply Cord.

The cable for cord-connected electric vehicle supply equipment (EVSE) shall comply with all of the following:

1. (1)

Be any of the types specified in [625.17\(B\)\(1\)](#) or hard service cord, junior hard service cord, or portable power cable types in accordance with [Table 400.4](#). Hard service cord, junior hard service cord, or portable power cable types shall be listed, as applicable, for exposure to oil and damp and wet locations.

2. (2)

Have an ampacity as specified in [Table 400.5\(A\)\(1\)](#) or, for 8 AWG and larger, in the 60°C (140°F) columns of [Table 400.5\(A\)\(2\)](#).

3. (3)

Have an overall length as specified in either of the following:

1. a.

When the interrupting device of the personnel protection system specified in [625.22](#) is located within the enclosure of the supply equipment or charging system, the power-supply cord shall be not more than the length indicated in (i) or (ii):

1. (i)

For portable equipment in accordance with [625.44\(A\)](#), the power-supply cord shall be not more than 300 mm (12 in.) long.

2. (ii)

For ~~fastened-in-place~~ hand fastened equipment in accordance with [625.44\(B\)](#), the power-supply cord shall be not more than 1.8 m (6 ft) long and the equipment shall be installed at a height that prevents the power-supply cord from contacting the floor when it is connected to the proper receptacle.

2. b.

When the interrupting device of the personnel protection system specified in [625.22](#) is located at the attachment plug, or within the first 300 mm (12 in.) of the power-supply cord, the overall cord length shall be not greater than 4.6 m (15 ft).

625.17(B) Output Cable to Electric Vehicles.

The output cable to electric vehicles shall be one of the following:

1. (1)

Listed Type EV, EVJ, EVE, EVJE, EVT, or EVJT flexible cable as specified in [Table 400.4](#)

2. (2)

An integral part of listed electric vehicle supply equipment
Informational Note No. 1: See UL 2594-2016, *Standard for Electric Vehicle Supply Equipment*, for information on conductive electric vehicle supply equipment.

Informational Note No. 2: See UL 2202-2009, *Standard for Electric Vehicle (EV) Charging System Equipment*, for information on conductive electric vehicle charging equipment.

625.17(C) Overall Cord and Cable Length.

The overall usable length shall not exceed 7.5 m (25 ft) unless equipped with a cable management system that is part of the listed electric vehicle supply equipment.

625.17(C)(1) Portable Equipment.

For portable EVSE, the cord-exposed usable length shall be measured from the face of the attachment plug to the face of the electric vehicle connector.

625.17(C)(2) Fastened-in-Place. Hand Fastened

Where the EVSE is ~~fastened-in-place~~, **hand fastened** the usable length of the output cable to the electric vehicle shall be measured from the cable exit of the electric vehicle supply equipment to the face of the electric vehicle connector.

Where the wireless power transfer equipment (WPTE) is fastened-in-place, the output cable to the primary pad shall be measured from the cable exit of the control box to the cable inlet at the primary pad.

625.44(B) Fastened-in-Place Hand Fastened Equipment.

Equipment that is fastened-in-place shall be connected to the premises wiring system by one of the following methods:

1. (1)

A nonlocking, 2-pole, 3-wire grounding-type receptacle outlet rated 125 volts or 250 volts, single phase, up to 50 amperes

2. (2)

A nonlocking, 3-pole, 4-wire grounding-type receptacle outlet rated 250 volts, three phase, up to 50 amperes

3. (3)

A nonlocking, 3-pole, 4-wire grounding-type receptacle outlet rated 125/250 volts, single phase, 30, 50, or 60 amperes

4. (4)

A nonlocking, 2-pole, 3-wire grounding-type receptacle outlet rated 60 volts dc maximum, 15 or 20 amperes

625.44(C) Fixed-in-Place Securely Fastened in Place Equipment.

All other EVSE and WPTE shall be permanently wired and ~~fixed-in-place~~ securely fastened in place to the supporting surface.



Public Comment No. 301-NFPA 70-2024 [Definition: Fixed-in-Place (as applied to electric vehicle ...]

~~Fixed-in-Place (as applied to electric vehicle power transfer systems and electric self-propelled vehicle power transfer systems).~~
Mounting means of equipment using fasteners that require a tool for removal.(625)(CMP-12)

Statement of Problem and Substantiation for Public Comment

The committee should combine the contents of Articles 625 and 627 back into a single article, using Parts as required, so that this definition can apply to a single article. This option to distinguish the term with a modifier in this manner is only allowed where there are multiple definitions for a term (NEC® Style Manual 2.1.2.7).

Related Item

- FCR-362

Submitter Information Verification

Submitter Full Name: Richard Holub

Organization: The DuPont Company, Inc.

Street Address:

City:

State:

Zip:

Submittal Date: Mon Jul 29 08:56:56 EDT 2024

Committee: NEC-P12



Public Comment No. 1155-NFPA 70-2024 [Definition: Remote Disconnect Control.]

Remote Disconnect Control.

An electric device and circuit that controls a disconnecting means through a relay or equivalent device. ~~(645)~~ (CMP-12)

Statement of Problem and Substantiation for Public Comment

The purpose of this Public Input is to revise the definition of Remote Disconnect Control to remove the designated Article number "(645)" so that the definition can be used throughout the code.

A companion Public Comment was submitted to 230.70(A)(4) to revise "Remote Control" to "Remote Disconnect Control" to utilize a defined term within the NEC. Remote Control is an undefined term in the NEC that can be misinterpreted. As digital control become more popular a user could misunderstand the term to believe they could remotely control the disconnect using a mobile app.

Related Public Comments for This Document

<u>Related Comment</u>	<u>Relationship</u>
Public Comment No. 1176-NFPA 70-2024 [Section No. 230.70(A)(4)]	
Public Comment No. 1176-NFPA 70-2024 [Section No. 230.70(A)(4)]	
<u>Related Item</u>	
• FR9155	

Submitter Information Verification

Submitter Full Name: Megan Hayes
Organization: NEMA
Street Address:
City:
State:
Zip:
Submittal Date: Fri Aug 16 09:26:30 EDT 2024
Committee: NEC-P12



Public Comment No. 505-NFPA 70-2024 [Definitions (100): Equipment, ... to Equipment, ...]

Definitions (100): Equipment, ... to Equipment, ...

Equipment, Portable. (Portable Equipment)

Equipment fed with portable cords or cables intended to be moved from one place to another. (640) (CMP-12)

Equipment, Portable. (Portable Equipment)

Equipment with electrical components suitable to be moved by a single person without mechanical aids. (511) (CMP-14)

Equipment, Portable. (Portable Equipment)

Equipment fed with portable cords or cables intended to be moved from one place to another. (520) (CMP-15)

Equipment, Portable. (Portable Equipment)

Equipment intended to be moved from one place to another. (530) (CMP-15)

Additional Proposed Changes

<u>File Name</u>	<u>Description</u>	<u>Approved</u>
CN_179.pdf		

Statement of Problem and Substantiation for Public Comment

NOTE: The following CC Note No. 179 appeared in the First Draft Report.

The CC directs that a task group be formed with members from CMP's 12, 14 and 15 for consideration of creating a single definition for the term "equipment, portable".

Related Item

- Correlating Committee Note No. 179

Submitter Information Verification

Submitter Full Name: CC Notes

Organization: NEC Correlating Committee

Street Address:

City:

State:

Zip:

Submittal Date: Tue Jul 30 22:31:40 EDT 2024

Committee: NEC-P12



Correlating Committee Note No. 179-NFPA 70-2024 [Definitions (100):

Equipment, ... to Equipment, ...]

Submitter Information Verification

Committee: NEC-AAC

Submittal Date: Thu May 09 09:43:06 EDT 2024

Committee Statement

Committee Statement: The CC directs that a task group be formed with members from CMP's 12, 14 and 15 for consideration of creating a single definition for the term "equipment, portable".

Ballot Results

✔ This item has passed ballot

12 Eligible Voters

1 Not Returned

11 Affirmative All

0 Affirmative with Comments

0 Negative with Comments

0 Abstention

Not Returned

McDaniel, Roger D.

Affirmative All

Ayer, Lawrence S.

Bowmer, Trevor N.

Hickman, Palmer L.

Holub, Richard A.

Jackson, Peter D.

Kendall, David H.

Manche, Alan

Osborne, Robert D.

Porter, Christine T.

Schultheis, Timothy James

Williams, David A.



Public Comment No. 497-NFPA 70-2024 [Definitions (100): Portable.... to Portable....]

Definitions (100): Portable.... to Portable....

Portable.

A device intended for indoor or outdoor use that is designed to be hand-carried from location to location, or easily transported without the use of other devices or equipment. (625) (CMP-12)

Portable.

X-ray equipment designed to be hand-carried. (660) (CMP-12)

Additional Proposed Changes

<u>File Name</u>	<u>Description</u>	<u>Approved</u>
CN_144.pdf		

Statement of Problem and Substantiation for Public Comment

NOTE: The following CC Note No. 144 appeared in the First Draft Report.

The Correlating Committee directs that CMP 12 form a task group to review the two definitions of "portable" and consider possible deletion as this is a commonly used adjective and does not need to be defined in the NEC.

Related Item

- Correlating Committee Note No. 144

Submitter Information Verification

Submitter Full Name: CC Notes

Organization: NEC Correlating Committee

Street Address:

City:

State:

Zip:

Submittal Date: Tue Jul 30 20:22:06 EDT 2024

Committee: NEC-P12



Correlating Committee Note No. 144-NFPA 70-2024 [Definitions (100):

Portable.... to Portable....]

Submitter Information Verification

Committee: NEC-AAC

Submittal Date: Wed May 08 17:00:37 EDT 2024

Committee Statement

Committee Statement: The Correlating Committee directs that CMP 12 form a task group to review the two definitions of “portable” and consider possible deletion as this is a commonly used adjective and does not need to be defined in the NEC.

Ballot Results

✓ **This item has passed ballot**

12 Eligible Voters

1 Not Returned

11 Affirmative All

0 Affirmative with Comments

0 Negative with Comments

0 Abstention

Not Returned

McDaniel, Roger D.

Affirmative All

Ayer, Lawrence S.

Bowmer, Trevor N.

Hickman, Palmer L.

Holub, Richard A.

Jackson, Peter D.

Kendall, David H.

Manche, Alan

Osborne, Robert D.

Porter, Christine T.

Schultheis, Timothy James

Williams, David A.



TITLE OF NEW CONTENT

Type your content here ...

620.8. Cybersecurity

Elevators, dumbwaiters, escalators, moving walks, lifts, and chairlifts, located in life safety-related infrastructures, that are connected to a communication network and have the capability to be controlled or permit control of any portion of the premises shall comply with either of the following:

(1) The ability to control the elevators, dumbwaiters, escalators, moving walks, lifts, and chairlifts is limited to a direct connection through a local nonnetworked interface.

(2) The elevators, dumbwaiters, escalators, moving walks, lifts, and chairlifts are connected through a networked interface complying with both of the following methods:

a. The elevators, dumbwaiters, escalators, moving walks, lifts, and chairlifts are identified as being evaluated for cybersecurity.

b. A cybersecurity assessment of the elevators, dumbwaiters, escalators, moving walks, lifts, and chairlifts is completed and documentation of the assessment and certification is available to those authorized to inspect, operate, and maintain the system.

Informational Note No. 1: See ANSI/ISA 62443, Cybersecurity Standards series, UL 2900 Cybersecurity Standard series, or the NIST Framework for Improving Critical Infrastructure Cybersecurity, Version 1.1 for assessment requirements.

Informational Note No. 2: Examples used to demonstrate the system has been investigated for cybersecurity vulnerabilities could be one of the following:

(1) The ISA Security Compliance Institute (ISCI) conformity assessment program

(2) Certification of compliance by a nationally recognized test laboratory

(3) Manufacturer certification for the specific type and brand of system provided

Informational Note No. 3: Cybersecurity is a specialized field requiring constant, vigilant attention to security vulnerabilities that could arise due to software defects, system configuration changes, or user interactions. Installation of devices that can be secured is an important first step but not sufficient to guarantee a secure system.

Informational Note No. 4: See NEMA CY70001-2023, Cybersecurity Implementation Guidance for Connected Electrical Infrastructure, for recommendations on how to meet this requirement.

Informational Note No. 5: Examples of life safety-related infrastructures include, but are not limited to, waste water treatment facilities, water supply facilities, police stations, call centers, financial centers, data centers, and military bases.

Statement of Problem and Substantiation for Public Comment

The Panel Statement to resolve Public Input 1246 reads "The question of cybersecurity protection is beyond the scope of CMP 12, but should be addressed by the Correlating Committee" is confusing and misleading. A Code Making Panel has a responsibility for several Articles, with each Article having a Scope. And that Scope falls under the jurisdiction of the Correlating Committee. The Scope of Article 620 reads: "This article covers the installation of electrical equipment and wiring used in connection with elevators, dumbwaiters, escalators, moving walks, platform lifts, and stairway chairlifts". There are obviously no issues with Public Input 1246 or this Public Comment being outside the scope of Article 620.

This Public Comment limits the suggested cybersecurity requirement to elevators, dumbwaiters, escalators, moving walks, lifts, and chairlifts located in life safety-related infrastructure and Informational Note No. 5 is added, providing examples of life safety-related infrastructure.

Most of the cybersecurity focus has been on IT systems. There has been very little public discussion about cybersecurity for Operational Technology (OT), but cyber attacks on OT occur on almost a daily basis. For an example of just how common cyber attacks on life safety related infrastructure have become, let's look at just the water supply and waste water treatment industry. The DNI (Director of National Intelligence), through the CTIIC (Cyber Threat Intelligence Integration Center) recently released a report of 12 cyber attacks on the industrial control systems of water utilities, water systems, and waste water treatment systems, for the six-month period from November 2023 through April 2024. This report can be found at

https://www.google.com/url?sa=t&source=web&rct=j&opi=89978449&url=https://www.dni.gov/files/CTIIC/documents/products/Recent_Cyber_Attacks_on_US_Infrastructure_Underscore_Vulnerability_of_Crit_June2024.pdf&ved=2ahUKEwi5gP7-m4elAxUakYkEHasyIRQQFnoECB8QAQ&usg=AOvVaw3hJL2DMIRs-CECFmewcXVP

While this example covered attacks on industrial control systems, successful attacks can occur on all electrical equipment that is continuously connected to the internet and even equipment that is only connected to the internet during system updates. (Cyber attacks can lay quiet for years, waiting for an update, and then do their intended damage during the update.)

Hackers can easily destroy unprotected equipment and shut down entire unprotected facilities. Our adversaries are continuously mounting cyber attacks on our life safety-related infrastructure. We have the ability, and obligation, to prevent this type of damage to our infrastructure from malicious cyber attacks.

Let's look at an example of a financial center. 110.3(A)(8) requires that a fire alarm system in the financial center, because it is life safety equipment, be evaluated in light of cybersecurity. However, there is no requirement for the other non-life safety equipment/systems within the financial center, such as elevators, which could easily be compromised by a cyber attack. The proposed text in this Public Comment addresses this vulnerability.

Informational Note No. 4 was added to correlate with FR 9040 (110.3(A)(8)), FR 9210 (240.6(D)), and FR 8219 (708.7).

THIS PUBLIC COMMENT SIMPLY REQUIRES THAT ELEVATORS, DUMBWAITERS, ESCALATORS, MOVING WALKS, LIFTS, AND CHAIRLIFTS, INSTALLED ONLY IN LIFE SAFETY-RELATED INFRASTRUCTURES, EITHER NOT BE CONNECTED TO THE INTERNET, OR IF THEY ARE CONNECTED TO THE INTERNET, THAT THEY BE "IDENTIFIED" FOR CYBERSECURITY AND THAT AN ASSESSMENT IS PROVIDED.

Related Item

- PI 1246

Submitter Information Verification

Submitter Full Name: Vincent Saporita

Organization: Saporita Consulting

Street Address:

City:

State:

Zip:

Submittal Date: Sat Aug 24 09:03:38 EDT 2024

Committee: NEC-P12



Public Comment No. 1145-NFPA 70-2024 [Section No. 620.12(A)(2)]

(2) Class 2 and Communications Circuits.

Communications cables used for Class 2 or communications circuits shall have a current limit equal to or greater than the current required to power the powered Class 2 or communications device. Communications cables shall ~~comply with 800.179~~ be listed in accordance with 722.2. The minimum conductor size for communications circuits shall be 24 AWG.

Statement of Problem and Substantiation for Public Comment

800.179 was deleted by FCR-248. Communications cables are limited-energy cables. Limited-energy cable listing requirements will be in 722.2.

Related Public Comments for This Document

Related Comment

Relationship

[Public Comment No. 1152-NFPA 70-2024 \[Section No. 620.36\]](#)

[Public Comment No. 1152-NFPA 70-2024 \[Section No. 620.36\]](#)

Related Item

- Global FCR-238

Submitter Information Verification

Submitter Full Name: Stanley Kaufman

Organization: CableSafe, Inc./OFS

Affiliation: Plastics Industry Association (PLASTICS)

Street Address:

City:

State:

Zip:

Submittal Date: Fri Aug 16 06:36:50 EDT 2024

Committee: NEC-P12



Public Comment No. 1315-NFPA 70-2024 [Section No. 620.16(C)]

(G) Available Fault Current Field Marking:

The elevator control panel shall be legibly marked in the field with the available fault current at its line terminals. The field marking(s) shall include the date the available fault current calculation was performed and shall meet the requirements of 110.24(D). The calculation shall be documented and made available to those authorized to design, install, inspect, maintain, or operate the system.

When modifications to the electrical system occur that affect the available fault current at the elevator control panel, the available fault current shall be verified or recalculated as necessary to ensure the elevator control panel's short circuit current rating is sufficient for the available fault current at the line terminals of the equipment. The required field marking(s) shall be adjusted to reflect the new level of available fault current.

Please see attached document.

Additional Proposed Changes

<u>File Name</u>	<u>Description</u>	<u>Approved</u>
Otis_public_comments_to_NEC_draft.docx	Otis public comment on 620.16(C)	

Statement of Problem and Substantiation for Public Comment

confusion and will likely create a safety risk, particularly concerning the second paragraph of the proposed language in 620.16(C) regarding modifications to the electrical system.

Related Item

- 620.16(C)

Submitter Information Verification

Submitter Full Name: John Kleine
Organization: Otis Elevator
Street Address:
City:
State:
Zip:
Submittal Date: Tue Aug 20 13:59:20 EDT 2024
Committee: NEC-P12

Otis Elevator opposes the addition of Article 620.16(C) for the following reasons:

Elevator control systems, as shipped from the factory, must be CSA B44.1/ASME A17.5 certified for fire and shock and marked with the short circuit current rating. Field changes to the controller that could impact short circuit current rating are not permitted.

A field marking requirement for the controller will create a conflict related to work responsibility between electrical and elevator personnel. This is an invitation for confusion and will likely create a safety risk, particularly concerning the second paragraph of the proposed language in 620.16(C) regarding modifications to the electrical system.

See attached document for more detailed opposition to the **Statement of Problem and Substantiation for Public Input**. [shown below]

Statement of Problem and Substantiation for Public Input (from submitter):	Opposition to Statement of Problem and Substantiation for Public Input:
It is critical that an elevator control panel can handle the available fault current at its point of installation.	NFPA70-2023 and prior editions recognize that elevator equipment short circuit current rating (SCCR) is equal to or greater than the available fault current at the main line disconnect switch (see 620.16(B)).
Given the design complexity of the elevator control panel, it can often have a low short circuit current rating.	Regardless of design complexity, the short circuit current rating must be marked on the elevator control panel per CSA B44.1/ASME A17.5.
This change provides much needed information to aid the electrical inspector when enforcing 620.16(B).	Article 620.1 Scope references CSA B44.1/ASME A17.5. Elevator equipment is required by ASME A17.1/CSA B44 Safety Code for Elevators and Escalators to be certified including marking in compliance with CSA B44.1/ASME A17.5 which aligns with Article 620.16(A) for SCCR marking.
It will help the inspector ensure that the elevator control panel is installed within its short-circuit current rating.	The electrical inspector applies 620.16(B) by comparing the SCCR marking on the elevator control panel with the available fault current marking on the main line disconnect switch per 620.51(D)(1) before the equipment is put into service.
Without this information, it is very difficult for an electrical inspector to verify the conditions of 620.16(B) are met.	Both marking requirements are already required in NFPA 70. Comparing the two marking requirements would not be a difficult task.

<p>This requirement was in the 2020 NEC under 620.51(D). It was modified in the 2023 NEC to apply to the elevator disconnecting means instead of the elevator control panel, because Section 620.51 covers the disconnecting means and not the elevator control panel (per the CMP statement).</p>	<p>The approved revision in 2023 was submitted as a clarification that the word “it” has always applied to the 620.51(D) disconnecting means, not the controller.</p>
<p>The marking of the elevator control panel should still be a requirement in the Code; however, it should be located in Section 620.16, as this section already addresses elevator control panel SCCR, and is consistent with the language for industrial machinery in 670.5(2).</p>	<p>The required marking of elevator control panels has been well established by the elevator safety code and other standards to be consistent with NFPA 70.</p> <p>The elevator controller is a listed and certified device, and the marking requirements are specified by ASME A17.1/CSA B44 and by reference to CSA B44.1/ASME A17.5.</p> <p>The additional field markings proposed for 620.16(C) would not be in alignment with these standards.</p> <p>Article 670 does not apply to elevator control equipment.</p>
<p>This proposal is also consistent with requirements found for the elevator disconnecting means in 620.51(D), along with other equipment such as service entrances in sections 110.24 (A) & (B).</p>	<p>Article 110.24(A) & (B) is supplemented by Article 620.51 relating to the elevator disconnecting means.</p>



Public Comment No. 1494-NFPA 70-2024 [Section No. 620.16(C)]

(C) Available Fault Current Field Marking.

The elevator control panel shall be ~~legibly~~ marked in the field with the available fault current at its line terminals. The field marking(s) shall include the date the available fault current calculation was performed and shall meet the requirements of 110.21(B). The calculation shall be documented and made available to those authorized to design, install, inspect, maintain, or operate the system.

When modifications to the electrical system occur that affect the available fault current at the elevator control panel, the available fault current shall be verified or recalculated as necessary to ensure the elevator control panel's short-circuit current rating is sufficient for the available fault current at the line terminals of the equipment. The required field marking(s) shall be adjusted to reflect the new level of available fault current.

Statement of Problem and Substantiation for Public Comment

:) as opposed to illegibly / unlegibly marked :)???

Related Item

- FR8634

Submitter Information Verification

Submitter Full Name: Joel Goergen

Organization: Cisco Systems, Inc.

Affiliation: Cisco Systems, Inc.

Street Address:

City:

State:

Zip:

Submittal Date: Fri Aug 23 15:23:16 EDT 2024

Committee: NEC-P12



Public Comment No. 1830-NFPA 70-2024 [Section No. 620.16(C)]

~~(G) Available Fault Current Field Marking:~~

~~The elevator control panel shall be legibly marked in the field with the available fault current at its line terminals. The field marking(s) shall include the date the available fault current calculation was performed and shall meet the requirements of 110.24(B). The calculation shall be documented and made available to those authorized to design, install, inspect, maintain, or operate the system.~~

~~When modifications to the electrical system occur that affect the available fault current at the elevator control panel, the available fault current shall be verified or recalculated as necessary to ensure the elevator control panel's short circuit current rating is sufficient for the available fault current at the line terminals of the equipment. The required field marking(s) shall be adjusted to reflect the new level of available fault current.~~

Statement of Problem and Substantiation for Public Comment

NEII (The National Elevator Industry, Inc.) opposes the addition of Article 620.16(C) and requests that it be deleted in its entirety for the following reasons:

Elevator control systems, as shipped from the factory, must be CSA B44.1/ASME A17.5 certified for fire and shock and marked with the short circuit current rating. Field changes to the controller that could impact short circuit current rating are not permitted.

A field marking requirement for the controller will create a conflict related to work responsibility between electrical and elevator personnel. This is an invitation for confusion and will likely create a safety risk, particularly concerning the second paragraph of the proposed language in 620.16(C) regarding modifications to the electrical system.

The text below provides a more detailed opposition to the Statement of Problem and Substantiation for Public Input.

Statement: It is critical that an elevator control panel can handle the available fault current at its point of installation.

NEII Opposition: NFPA70-2023 and prior editions recognize that elevator equipment short circuit current rating (SCCR) is equal to or greater than the available fault current at the main line disconnect switch (see 620.16(B)).

Statement: Given the design complexity of the elevator control panel, it can often have a low short circuit current rating.

NEII Opposition: Regardless of design complexity, the short circuit current rating must be marked on the elevator control panel per CSA B44.1/ASME A17.5.

Statement: This change provides much needed information to aid the electrical inspector when enforcing 620.16(B).

NEII Opposition: Article 620.1 Scope references CSA B44.1/ASME A17.5. Elevator equipment is required by ASME A17.1/CSA B44 Safety Code for Elevators and Escalators to be certified including marking in compliance with CSA B44.1/ASME A17.5 which aligns with Article 620.16(A) for SCCR marking.

Statement: It will help the inspector ensure that the elevator control panel is installed within its short-circuit current rating.

NEII Opposition: The electrical inspector applies 620.16(B) by comparing the SCCR marking on the elevator control panel with the available fault current marking on the main line disconnect switch per 620.51(D)(1) before the equipment is put into service.

Statement: Without this information, it is very difficult for an electrical inspector to verify the conditions of 620.16(B) are met.

NEII Opposition: Both marking requirements are already required in NFPA 70. Comparing the two marking requirements would not be a difficult task.

Statement: This requirement was in the 2020 NEC under 620.51(D). It was modified in the 2023 NEC to apply to the elevator disconnecting means instead of the elevator control panel, because Section 620.51 covers the disconnecting means and not the elevator control panel (per the CMP statement).

NEII Opposition: The approved revision in 2023 was submitted as a clarification that the word "it" has always applied to the 620.51(D) disconnecting means, not the controller.

Statement: The marking of the elevator control panel should still be a requirement in the Code; however, it should be located in Section 620.16, as this section already addresses elevator control panel SCCR, and is consistent with the language for industrial machinery in 670.5(2).

NEII Opposition: The required marking of elevator control panels has been well established by the elevator safety code and other standards to be consistent with NFPA 70.

The elevator controller is a listed and certified device, and the marking requirements are specified by ASME A17.1/CSA B44 and by reference to CSA B44.1/ASME A17.5.

The additional field markings proposed for 620.16(C) would not be in alignment with these standards.

Article 670 does not apply to elevator control equipment.

Statement: This proposal is also consistent with requirements found for the elevator disconnecting means in 620.51(D), along with other equipment such as service entrances in sections 110.24 (A) & (B).

NEII Opposition: Article 110.24(A) & (B) is supplemented by Article 620.51 relating to the elevator disconnecting means.

Related Item

• PI 3826-NFPA 70-2023 • FR 8634-NFPA 70-2024

Submitter Information Verification

Submitter Full Name: Kevin Brinkman

Organization: National Elevator Industry, In

Street Address:

City:

State:

Zip:

Submittal Date: Tue Aug 27 16:14:48 EDT 2024



Public Comment No. 1971-NFPA 70-2024 [Section No. 620.16(C)]

~~(G) Available Fault Current Field Marking:~~

~~The elevator control panel shall be legibly marked in the field with the available fault current at its line terminals. The field marking(s) shall include the date the available fault current calculation was performed and shall meet the requirements of 110.24(B). The calculation shall be documented and made available to those authorized to design, install, inspect, maintain, or operate the system.~~

~~When modifications to the electrical system occur that affect the available fault current at the elevator control panel, the available fault current shall be verified or recalculated as necessary to ensure the elevator control panel's short circuit current rating is sufficient for the available fault current at the line terminals of the equipment. The required field marking(s) shall be adjusted to reflect the new level of available fault current.~~

Statement of Problem and Substantiation for Public Comment

TK Elevator opposes the addition of Article 620.16(C) and requests that it be deleted in its entirety for the following reasons:

Elevator control systems, as shipped from the factory, must be CSA B44.1/ASME A17.5 certified for fire and shock and marked with the short circuit current rating. Field changes to the controller that could impact short circuit current rating are not permitted.

A field marking requirement for the controller will create a conflict related to work responsibility between electrical and elevator personnel. This is an invitation for confusion and will likely create a safety risk, particularly concerning the second paragraph of the proposed language in 620.16(C) regarding modifications to the electrical system.

The text below provides a more detailed opposition to the Statement of Problem and Substantiation for Public Input.

Statement: It is critical that an elevator control panel can handle the available fault current at its point of installation.

TK ELEVATOR Opposition: NFPA70-2023 and prior editions recognize that elevator equipment short circuit current rating (SCCR) is equal to or greater than the available fault current at the main line disconnect switch (see 620.16(B)).

Statement: Given the design complexity of the elevator control panel, it can often have a low short circuit current rating.

TK ELEVATOR Opposition: Regardless of design complexity, the short circuit current rating must be marked on the elevator control panel per CSA B44.1/ASME A17.5.

Statement: This change provides much needed information to aid the electrical inspector when enforcing 620.16(B).

TK ELEVATOR Opposition: Article 620.1 Scope references CSA B44.1/ASME A17.5. Elevator equipment is required by ASME A17.1/CSA B44 Safety Code for Elevators and Escalators to be certified including marking in compliance with CSA B44.1/ASME A17.5 which aligns with Article 620.16(A) for SCCR marking.

Statement: It will help the inspector ensure that the elevator control panel is installed within its short-circuit current rating.

TK ELEVATOR Opposition: The electrical inspector applies 620.16(B) by comparing the SCCR marking on the elevator control panel with the available fault current marking on the main line disconnect switch per 620.51(D)(1) before the equipment is put into service.

Statement: Without this information, it is very difficult for an electrical inspector to verify the conditions of 620.16(B) are met.

TK ELEVATOR Opposition: Both marking requirements are already required in NFPA 70. Comparing the two marking requirements would not be a difficult task.

Statement: This requirement was in the 2020 NEC under 620.51(D). It was modified in the 2023 NEC to apply to the elevator disconnecting means instead of the elevator control panel, because Section 620.51 covers the disconnecting means and not the elevator control panel (per the CMP statement).

TK ELEVATOR Opposition: The approved revision in 2023 was submitted as a clarification that the word "it" has always applied to the 620.51(D) disconnecting means, not the controller.

Statement: The marking of the elevator control panel should still be a requirement in the Code; however, it should be located in Section 620.16, as this section already addresses elevator control panel SCCR, and is consistent with the language for industrial machinery in 670.5(2).

TK ELEVATOR Opposition: The required marking of elevator control panels has been well established by the elevator safety code and other standards to be consistent with NFPA 70.

The elevator controller is a listed and certified device, and the marking requirements are specified by ASME A17.1/CSA B44 and by reference to CSA B44.1/ASME A17.5.

The additional field markings proposed for 620.16(C) would not be in alignment with these standards.

Article 670 does not apply to elevator control equipment.

Statement: This proposal is also consistent with requirements found for the elevator disconnecting means in 620.51(D), along with other equipment such as service entrances in sections 110.24 (A) & (B).

TK ELEVATOR Opposition: Article 110.24(A) & (B) is supplemented by Article 620.51 relating to the elevator disconnecting means.

Related Item

• PI 3826-NFPA 70-2023 • FR 8634-NFPA 70-2024

Submitter Information Verification

Submitter Full Name: John Henderson

Organization: TK Elevator

Street Address:

City:

State:

Zip:

Submittal Date: Wed Aug 28 13:36:08 EDT 2024

Committee: NEC-P12



Public Comment No. 1147-NFPA 70-2024 [Section No. 620.21(A)(1)]

(1) Hoistways and Pits.

(a) Types CL2P, CL2R, and CL2 cables shall be permitted, provided the cables are supported and protected from physical damage. Substitute cables for Class 2 cables installed in accordance with ~~794.135(D)~~ - 722.122 shall be permitted.

(b) Types CL4P, CL4R, and CL4 cables shall be permitted, provided the cables are supported and protected from physical damage.

(c) Flexible cords and cables that are components of listed equipment and used in circuits operating at 30 volts rms or less or 42 volts dc or less shall be permitted, provided the cords and cables are supported and protected from physical damage and are of a jacketed and flame-retardant type.

(d) The following wiring methods shall be permitted in the hoistway in lengths not to exceed 1.8 m (6 ft):

(5) Flexible metal conduit.

(6) Liquidtight flexible metal conduit.

(7) Liquidtight flexible nonmetallic conduit.

(8) Flexible cords and cables, or conductors grouped together and taped or corded, shall be permitted to be installed without a raceway. They shall be located to be protected from physical damage, shall be of a flame-retardant type, and shall be part of one of the following:

(9) Listed equipment

(10) Driving machine

(11) Driving machine brake

Exception to (A)(1)(d)(1), (A)(1)(d)(2), and (A)(1)(d)(3): The conduit length shall not be required to be limited between risers and limit switches, interlocks, operating buttons, and similar devices.

(l) A sump pump or oil recovery pump located in the pit shall be permitted to be cord connected. The cord shall be a hard usage oil-resistant type, of a length not to exceed 1.8 m (6 ft), and shall be located to be protected from physical damage.

(m) Hard-service cords and junior hard-service cords that conform to the requirements of Table 400.4 shall be permitted as flexible connections between the fixed wiring in the hoistway and hoistway access switches when located in the hoistway door sight guard.

Informational Note: See ASME A17.1-2022/CSA B44-2022, *Safety Code for Elevators and Escalators*.

Statement of Problem and Substantiation for Public Comment

794.135(D), cable substitutions, is replaced by 722.122 in the First Draft. Correcting that reference is the only change recommended; other underlining was done by TerraView.

Related Item

- Global FCR-238

Submitter Information Verification

Submitter Full Name: Stanley Kaufman

Organization: CableSafe, Inc./OFS

Affiliation: Plastics Industry Association (PLASTICS)

Street Address:

City:

State:

Zip:

Submittal Date: Fri Aug 16 06:50:38 EDT 2024

Committee: NEC-P12



Public Comment No. 1149-NFPA 70-2024 [Section No. 620.21(B)(2)]

(2) Class 2 Circuit Cables.

Types CL2P, CL2R, and CL2 cables shall be permitted to be installed within escalators and moving walkways, provided the cables are supported and protected from physical damage. Substitute cables for Class 2 cables installed in accordance with ~~794.135(D)~~ - 722.122, shall be permitted.

Statement of Problem and Substantiation for Public Comment

794.135(D), cable substitutions, is replaced by 722.122 in the First Draft.

Related Public Comments for This Document

<u>Related Comment</u>	<u>Relationship</u>
<u>Public Comment No. 1151-NFPA 70-2024 [Section No. 620.21(C)(2)]</u>	

Related Item

- Global FCR-238

Submitter Information Verification

Submitter Full Name: Stanley Kaufman
Organization: CableSafe, Inc./OFS
Affiliation: Plastics Industry Association (PLASTICS)
Street Address:
City:
State:
Zip:
Submittal Date: Fri Aug 16 06:56:22 EDT 2024
Committee: NEC-P12



Public Comment No. 1151-NFPA 70-2024 [Section No. 620.21(C)(2)]

(2) Class 2 Circuit Cables.

Types CL2P, CL2R, and CL2 cables shall be permitted to be installed within platform lifts and stairway chairlift runways and machinery spaces, provided the cables are supported and protected from physical damage. Substitute cables for Class 2 cables installed in accordance with ~~794.135(D)~~ - 722.122 shall be permitted.

Statement of Problem and Substantiation for Public Comment

794.135(D), cable substitutions, is replaced by 722.122 in the First Draft.

Related Public Comments for This Document

<u>Related Comment</u>	<u>Relationship</u>
<u>Public Comment No. 1149-NFPA 70-2024 [Section No. 620.21(B)(2)]</u>	
<u>Related Item</u>	
• Global FCR-238	

Submitter Information Verification

Submitter Full Name: Stanley Kaufman
Organization: CableSafe, Inc./OFS
Affiliation: Plastics Industry Association (PLASTICS)
Street Address:
City:
State:
Zip:
Submittal Date: Fri Aug 16 07:00:11 EDT 2024
Committee: NEC-P12



Public Comment No. 1152-NFPA 70-2024 [Section No. 620.36]

620.36 Different Systems in One Raceway or Traveling Cable.

Optical fiber cables and conductors for operating devices, operation and motion control, power, signaling, fire alarm, lighting, heating, and air-conditioning circuits of 1000 volts or less shall be permitted to be run in the same traveling cable or raceway system if all conductors are insulated for the maximum voltage applied to any conductor within the cables or raceway system and if all live parts of the equipment are insulated from ground for this maximum voltage. Traveling cable or raceway shall also be permitted to include shielded pairs, coaxial cables, and other communications circuits. Type CMP-LP or CMR-LP cables ~~complying~~ listed in accordance with 600.722.479-2, shall be permitted in raceways.

Statement of Problem and Substantiation for Public Comment

800.179 was deleted by FCR-248. Communications cables are limited-energy cables. Limited-energy cable listing requirements will be in 722.2.

Related Public Comments for This Document

<u>Related Comment</u>	<u>Relationship</u>
Public Comment No. 1145-NFPA 70-2024 [Section No. 620.12(A)(2)]	
Public Comment No. 1145-NFPA 70-2024 [Section No. 620.12(A)(2)]	

Related Item

- Global FCR-238

Submitter Information Verification

Submitter Full Name: Stanley Kaufman
Organization: CableSafe, Inc./OFS
Affiliation: Plastics Industry Association (PLASTICS)
Street Address:
City:
State:
Zip:
Submittal Date: Fri Aug 16 07:03:01 EDT 2024
Committee: NEC-P12



(C) Modifications.

If modifications, additions, or deletions to the elevator system(s) occur, selective coordination of the elevator system(s) OCPDs with all supply-side and load-side OCPDs shall be re-evaluated.

Exception: Selective coordination shall not be required between two overcurrent devices located in series if no loads are connected in parallel with the downstream device.

~~Informational Note: See Figure Informational Note 620.62 for an example of how OCPDs supplying elevators selectively coordinate with all supply-side OCPDs.~~

~~Figure Informational Note 620.62 Selective Coordination for Overcurrent Protective Devices Supplying More Than One Elevator.~~

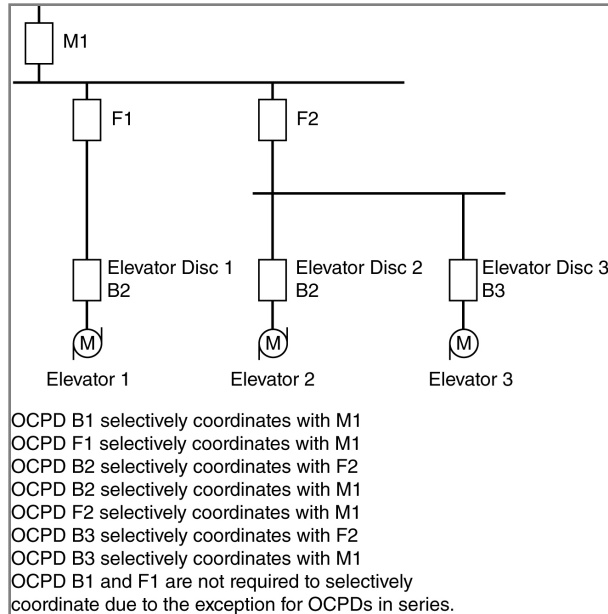

Statement of Problem and Substantiation for Public Comment

Please note that it is NOT my intent to delete this drawing, but rather to point out the problem with it. The drawing indicates that OCPD B1 coordinates with M1. The problem is...there is no B1 in the drawing. The disconnect on the left is probably supposed to be B1, but instead two of the three disconnects are marked as B2. I know of no way in Terraviva that I can fix this, other than to just point it out to the CMP.

Related Item

- FR 8703

Submitter Information Verification

Submitter Full Name: Ryan Jackson

Organization: Self-employed

Street Address:

City:

State:

Zip:

Submittal Date: Mon Aug 05 15:08:14 EDT 2024

Committee: NEC-P12



Public Comment No. 1354-NFPA 70-2024 [Section No. 625.2]

625.2 Listing Requirements.

Electric vehicle power transfer system equipment for the purposes of charging, power export, or bidirectional current flow shall be listed- ~~for EVSE use~~ .

Statement of Problem and Substantiation for Public Comment

"listed for EVSE use" would mean that wireless charging system should also be listed to UL 2594. However, UL 2594 is only for conductive charging, and wireless charging is out of its scope. The same can be said for bidirectional EVSE, when they have their own product specific standard, UL 9741.

Related Item

- FR 8240

Submitter Information Verification

Submitter Full Name: Indra Wiryadinata

Organization: Tesla

Street Address:

City:

State:

Zip:

Submittal Date: Wed Aug 21 10:26:52 EDT 2024

Committee: NEC-P12



Public Comment No. 1401-NFPA 70-2024 [Section No. 625.2]

625.2 Listing Requirements.

Electric vehicle power transfer system equipment for the purposes of charging, power export, or bidirectional current flow shall be listed- ~~for EVSE use~~ .

Statement of Problem and Substantiation for Public Comment

"Listed for EVSE use" implies that all equipment must be listed to the EVSE standard (UL 2594), but there are a number of standards that cover the array of charging equipment available and may not be covered by the EVSE standard. As examples bidirectional equipment is covered by UL 9741 and DC fast charging equipment is covered by UL 2202. Deleting "for EVSE use" allows the different types of equipment to be listed for their purpose and be acceptable for use by this section.

Related Item

- First Revision No. 8240-NFPA 70-2024 [Section No. 625.6]

Submitter Information Verification

Submitter Full Name: John Cowans

Organization: Siemens

Street Address:

City:

State:

Zip:

Submittal Date: Thu Aug 22 10:29:56 EDT 2024

Committee: NEC-P12



Public Comment No. 1740-NFPA 70-2024 [Section No. 625.2]

625.2 Listing Requirements.

Electric vehicle power transfer system equipment for the purposes of charging, power export, or bidirectional current flow shall be listed for EVSE use. All equipment must be suitably labeled with the logo of the listing agency, identification of the standard(s) listed to, a model number and a unique serial number. Equipment that is capable of being derated per 625.42(B) must have label space for the new rating to be durably recorded.

Additional Proposed Changes

<u>File Name</u>	<u>Description</u>	<u>Approved</u>
Clipper-creek-Rating-Plate.jpg	Sample suitable listing plate from Clipper Creek, showing UL and Intertek NRTL conformance claims	

Statement of Problem and Substantiation for Public Comment

I work as an inspector for residential and light commercial properties.

During an inspection people in my line of work typically look at breaker sizes, equipment rating labels, verify the wire size printed in tiny letters on cables.

We look for signs of stress such as wire discoloration. With an EVSE the equipment may never have been subject to the maximum possible stress, just because of what vehicles have charged: thus there may be a big overcurrent problem with no physical evidence of wire discoloration.

In some cases we alert customers about recalls and counterfeit products. And there are PLENTY of counterfeit and non-listed or fake-listed EVSE on Amazon.com (just do a quick search and you will see).

Thus, it is core to our job to be able to validate an electrical panel and installation from visual inspection alone. Typically we won't have access to any installation manuals or plans or websites.

For that we need proper labels. Nobody should be installing anything without such a label.

Thus I support the consolidation of 625.6 and 625.22 into this section. But encourage the CMP to describe what a proper label looks like, and encourage the CMP to provide space for a durable "derated" label when needed, and facilitate consumer recalls by the CSPC or others.

The goal of the proposed change is to help make sure more users of NFPA 70 know what a proper label looks like. EVSE equipment involves high currents for long periods of time. It's simply more important than the type of dryer/range/HVAC equipment many NFPA 70 users have been installing forever. The rating label and details matter for fire safety for EVSE due to the long continuous loads that can punish any small mistakes.

Related Public Comments for This Document

<u>Related Comment</u>	<u>Relationship</u>
Public Comment No. 1811-NFPA 70-2024 [New Section after 210.8(E)]	
Public Comment No. 1833-NFPA 70-2024 [Section No. 625.42(B)]	

<u>Related Item</u>					
• Public Input No. 2803- NFPA 70-2023 [New Section after 625.1]	• Public Input No. 2802- NFPA 70-2023 [Section No. 625.6]	• Public Input No. 1365- NFPA 70-2023 [Section No. 625.22]	• Public Input No. 1802- NFPA 70-2023 [Section No. 625.54]	• TIA Log #1748 and #1749 (on compatibility of equipment)	• TIA-23-3, Log #1748 and #1749 (on compatibility of equipment)

Submitter Information Verification

Submitter Full Name: Bryce Nesbitt
Organization: Obviously Inspects / Obviously Permit and Entitlement Consultancy
Street Address:
City:
State:
Zip:
Submittal Date: Mon Aug 26 21:15:25 EDT 2024
Committee: NEC-P12

FOR USE WITH ELECTRIC VEHICLES

CAUTION Risk of electrical shock or burn. This product contains no user serviceable parts.

CAUTION Do not use this product if the EV cable is damaged.

WARNING Automatic CCID reset provided.

WARNING Only for use with vehicles that do not require ventilation.

WARNING This unit employs parts, such as switches and relays that tend to produce arcs or sparks and must be mounted not less than 18 inches above the floor if installed in an enclosed garage.

**ELECTRIC VEHICLE
CHARGING STATION
MODEL: DS-100**

PART #: 0230-00-003

SERIAL: CS1C161044511 3XZ1

CONFIG: CS-40-C13-L25-59



40A BRANCH CIRCUIT PROTECTOR

**INPUT: 208-240 VAC, 50/60Hz, 120V TO GND
32AMPS CONTINUOUS**

**OUTPUT: 208-240 VAC, 50/60Hz, 120V TO GND
32AMPS CONTINUOUS**

**SHORT CIRCUIT RATING:
5000RMS SYMMETRICAL AMPS at 240VAC**

**SAE J1772 COMPLIANT / TYPE 4 ENCLOSURE
TEMPERATURE RATING: -30°C to +40°C**

This device complies with Part 15 of FCC Rules.
Operation is subject to the following two conditions:
(1) This device may not cause harmful interference, and
(2) This device must accept any interference received, including interference that may cause undesired operation.



**CLIPPERCREEK, INC
11850 KEMPER ROAD
AUBURN, CA 95603
WWW.CLIPPERCREEK.NET**

**ELECTRIC VEHICLE CHARGING STATION
FOR USE WITH ELECTRIC VEHICLES**

MODEL NUMBER: HCS-40

PART NUMBER: 0909-00-003

SERIAL NUMBER: HC1C161044633

CONFIGURATION: HCS-40-C13-L25-45



40A BRANCH CIRCUIT PROTECTOR

**INPUT: 208-240 VAC, 50/60Hz, 120V TO GND
32AMPS CONTINUOUS**

**OUTPUT: 208-240 VAC, 50/60Hz, 120V TO GND
32AMPS CONTINUOUS**

**SHORT CIRCUIT RATING:
5000RMS SYMMETRICAL AMPS at 240VAC**

**SAE J1772 COMPLIANT / TYPE 4 ENCLOSURE
AMBIENT TEMPERATURE RATING: -30°C to +50°C**

**LA STATION DE RECHARGE POUR UTILISATION
AVEC DES VÉHICULES ÉLECTRIQUES**

NUMÉRO DE MODEL: HCS-40

NUMÉRO DE PIÈCE: 0909-00-003

NUMÉRO DE SÉRIE: HC1C161044633

CONFIGURATION: HCS-40-C13-L25-45



**40A PROTECTOR DE CIRCUITS DE DÉRIVATION
ENTRÉE: 208-240 VAC, 50/60Hz, 120V À LA TERRE
32AMPS CONTINU**

**SORTIE: 208-240 VAC, 50/60Hz, 120V À LA TERRE
32AMPS CONTINU**

**CLASSIF DE COURT-CIRCUIT:
5000RMS SYMÉTRIQUE AMPS À 240VAC**

**SAE J1772 CONFORME / COFFRET TYPE 4
TEMPÉRATURE NOMINALE: -30°C to +50°C**



**CLIPPERCREEK, INC
11850 KEMPER ROAD
AUBURN, CA 95603
WWW.CLIPPERCREEK.NET**



Public Comment No. 1871-NFPA 70-2024 [New Section after 625.4]

625.9 Qualified Persons

(A) Installation

Electric Vehicle Power Transfer Equipment shall be installed by qualified persons

Exception: Shall not apply to the use of portable electric vehicle chargers

Informational Note: See NECA 413-2024, Standard for Installing and Maintaining Electric Vehicle Supply Equipment (EVSE), or other ANSI approved installation standards.

Statement of Problem and Substantiation for Public Comment

This public comment is submitted in response to the resolution of PI-4394 and related committee statement. An exception has been added to address the committee's concerns related to portable chargers, and service and maintenance for EVPTSE is already by the general Service and Maintenance Requirement in 100.17. An informational note to the revised version of NECA 413 will provide reference relevant to installation and maintenance practices for these types of installations.

Related Item

- PI-4394

Submitter Information Verification

Submitter Full Name: Jeff Noren

Organization: National Electrical Contractors Association

Street Address:

City:

State:

Zip:

Submittal Date: Tue Aug 27 19:14:51 EDT 2024

Committee: NEC-P12



625.7 Markings

Electric vehicle supply equipment shall have permanent markings on the outside of the equipment enclosure that are visible after installation. The following markings shall be included:

(1) Manufacturer's name, trademark, or other descriptive marking by which the organization responsible for the product can be identified.

(2) Supply voltage, number of phases, frequency, and full-load current for each incoming supply circuit.

(3) Short-circuit current rating of the electric vehicle supply equipment based on one of the following:

a. Short-circuit current rating of a listed and labeled assembly

b. Short-circuit current rating established utilizing an approved method

Informational Note: See UL 2594, Standard Electric Vehicle Supply Equipment, for an example of an approved method.

(4) The environmental enclosure type number.

Statement of Problem and Substantiation for Public Comment

Thank you to the committee for the provided resolution statement. I would like to request that the panel reconsider the original PI #3816 to be included. I am a TC voting member of UL 2202 and 2594, also a manufacturer of EVSE and understand that there are marking requirements for some minimum basic information such as input/output volts/amps/phases/frequency, etc. However, while these standards require this type of equipment to be tested and evaluated for short circuit, they do not require this rating such as short-circuit current rating to be marked on the equipment. As this type of equipment and its installation has become very prevalent and it is managed and used by the everyday consumer, it is important to have and know what the short-circuit current rating of the equipment and have it marked where readily visible so that the AHJ can ensure that it is installed properly, safely and in compliance with the code.

Related Item

- PI 3816

Submitter Information Verification

Submitter Full Name: Kevin Arnold

Organization: Eatons Bussmann Business

Street Address:

City:

State:

Zip:

Submittal Date: Wed Aug 28 14:08:57 EDT 2024

Committee: NEC-P12



Public Comment No. 1195-NFPA 70-2024 [Section No. 625.4]

625.4 Voltages.

~~Unless other voltages are specified, the nominal ac system voltages of 120, 120/240, 208Y/120, 240, 480Y/277, 480, 600Y/347, 600, or 1000 volts or dc system input voltages of up to 1500 volts shall be used to supply equipment covered by this Article 627.~~

~~Output voltages to the electric vehicle are not specified.~~

Statement of Problem and Substantiation for Public Comment

The purpose of this comment is to delete 625.4. Since 625.2 requires EVTPSE to be listed, there is no need for the NEC to identify what voltages are suitable to supply EVPTSE. Supply voltage criteria is clearly outlined in the applicable safety product standard the EVPTSE is listed to. This section is superfluous and adds no value to the code.

Related Item

- FR8307

Submitter Information Verification

Submitter Full Name: Megan Hayes

Organization: NEMA

Street Address:

City:

State:

Zip:

Submittal Date: Fri Aug 16 23:46:20 EDT 2024

Committee: NEC-P12



Public Comment No. 1321-NFPA 70-2024 [Section No. 625.4]

625.4 Voltages.

Unless other voltages are specified, the nominal ac system voltages of 120, 120/240, 208Y/120, 240, 480Y/277, 480, 600Y/347, 600, or 1000 volts or dc system input voltages of up to 1500 volts shall be used to supply equipment covered by this Article ~~627~~ **625**.

Output voltages to the electric vehicle are not specified.

Statement of Problem and Substantiation for Public Comment

Typo error referring to a different article.

Related Item

- 3491

Submitter Information Verification

Submitter Full Name: Indra Wiryadinata

Organization: Tesla

Street Address:

City:

State:

Zip:

Submittal Date: Tue Aug 20 15:27:34 EDT 2024

Committee: NEC-P12



Public Comment No. 1908-NFPA 70-2024 [Section No. 625.4]

625.4 - Voltages:

~~Unless other voltages are specified, the nominal ac system voltages of 120, 120/240, 208Y/120, 240, 480Y/277, 480, 600Y/347, 600, or 1000 volts or dc system input voltages of up to 1500 volts shall be used to supply equipment covered by this Article 627.~~

~~Output voltages to the electric vehicle are not specified.~~

Statement of Problem and Substantiation for Public Comment

This section does not appear to serve a guiding purpose.

The term "Unless other voltages are specified" nullifies the voltage listings given. Maximums are specified elsewhere in the code. The reference to "this Article 627" in section 625 appears to be a typo. 627.4 has similar issues.

What's important for EVSE are the output voltages, which are not regulated by the NEC. The input could be any voltage if properly transformed, from any power source from a kilovolt power company line to a suitably large hamster wheel. Listed EVSE are well regulated, and duplicate requirements serve to separate the international market from the USA market, potentially to the detriment of consumers in the USA.

With length being an issue with the accessibility of the code, perhaps this section can be left out?

Related Item

- Public Input No. 3491-NFPA 70-2023 [Section No. 625.4]

Submitter Information Verification

Submitter Full Name: Bryce Nesbitt

Organization: Obviously Inspects

Street Address:

City:

State:

Zip:

Submittal Date: Wed Aug 28 02:32:49 EDT 2024

Committee: NEC-P12



Public Comment No. 400-NFPA 70-2024 [Section No. 625.4]

625.4 Voltages.

Unless other voltages are specified, the nominal ac system voltages of 120, 120/240, 208Y/120, 240, 480Y/277, 480, 600Y/347, 600, or 1000 volts or dc system input voltages of up to 1500 volts shall be used to supply equipment covered by this ~~Article 627~~ article.

Output voltages to the electric vehicle are not specified.

Statement of Problem and Substantiation for Public Comment

In FR8307, the sentence in 625.4 was revised to update the voltage levels in the requirement. Although not part of the PI associated with this First Revision, an additional change was made to change "this article" to "Article 627." There are two problems here in that we are in article 625 so the reference to 627 is simply incorrect; and second, this is a violation of 4.1.4 of the style manual and the original text of "this article" is correct.

Related Item

- FR8307

Submitter Information Verification

Submitter Full Name: Joseph Bablo

Organization: UL Solutions

Street Address:

City:

State:

Zip:

Submittal Date: Tue Jul 30 15:03:41 EDT 2024

Committee: NEC-P12



625.17 Cords and Cables.

(A) Power-Supply Cord.

The cable for cord-connected electric vehicle supply equipment (EVSE) shall comply with all of the following:

- (1) Be any of the types specified in 625.17(B)(1) or hard service cord, junior hard service cord, or portable power cable types in accordance with Table 400.4. Hard service cord, junior hard service cord, or portable power cable types shall be listed, as applicable, for exposure to oil and damp and wet locations.
- (2) Be of a type and ampacity as specified in Table 400.5(A)(1). For 8 AWG and larger, the cable shall be permitted to be of a type as specified in Table 400.5(A)(2) with an ampacity as specified in the 60°C (140°F) column of Table 400.5(A)(2).
- (3) Have an overall length as specified in either of the following:
 - (4) When the interrupting device of the personnel protection system is located within the enclosure of the supply equipment or charging system, the power-supply cord shall be not more than the length indicated in either of the following:
 - (5) For portable equipment in accordance with 625.44(A), the power-supply cord shall be not more than 300 mm (12 in.) long.
 - (6) For

~~fastened-in-place equipment in~~

a.

i. hand fastened equipment in accordance with 625.44(B), the power-supply cord shall be not more than 1.8 m (6 ft) long and the equipment shall be installed at a height that prevents the power-supply cord from contacting the floor when it is connected to the proper receptacle.

b. When the interrupting device of the personnel protection system is located at the attachment plug or within the first 300 mm (12 in.) of the power-supply cord, the overall cord length shall be not greater than 4.6 m (15 ft).

(B) Output Cable to Electric Vehicles.

The output cable to electric vehicles shall be one of the following:

- (1) Listed Type EV, EVJ, EVE, EVJE, EVT, or EVJT flexible cable as specified in Table 400.4
- (2) An integral part of listed electric vehicle supply equipment

Informational Note No. 1: See UL 2594-2016, *Standard for Electric Vehicle Supply Equipment*, for information on conductive electric vehicle supply equipment.

Informational Note No. 2: See UL 2202-2009, *Standard for Electric Vehicle (EV) Charging System Equipment*, for information on conductive electric vehicle charging equipment.

(C) Overall Cord and Cable Length.

The overall usable length shall not exceed 7.5 m (25 ft) unless equipped with a cable management system that is part of the listed electric vehicle supply equipment.

(1) Portable Equipment.

For portable EVSE, the cord-exposed usable length shall be measured from the face of the attachment plug to the face of the electric vehicle connector.

~~(2) Fastened-in-Place Hand-Fastened.~~

(a) Where the EVSE is hand fastened-in-place, the usable length of the output cable to the electric vehicle shall be measured from the cable exit of the electric vehicle supply equipment to the face of the electric vehicle connector.

(b) Where the wireless power transfer equipment (WPTE) is hand fastened-in-place, the output cable to the primary pad shall be measured from the cable exit of the control box to the cable inlet at the primary pad.

(D) Interconnecting Cabling Systems.

Other cabling systems that are integral parts of listed EVSE and are intended to interconnect pieces of equipment within an EVSE system using approved installation methods shall be permitted.

Additional Proposed Changes

<u>File Name</u>	<u>Description</u>	<u>Approved</u>
Substantion_for_Comments_for_Fixed-Fastened.docx	Substantiation and overall changes	

Statement of Problem and Substantiation for Public Comment

Public inputs regarding the CMP-12 definitions for "Fixed-in-place" and "Fastened-in-place" by two prominent Code trainers and commentators (PI-2460 by Mike Holt and PI-4230 and 4231 by Jeffrey Simpson) clearly display the confusion that exists in the public with these definitions (their Public Inputs were resolved due to their errant substantiation based on their misunderstanding). Though technically correct as is, these minor changes will simplify and clarify the Code by modifying the one term and using a consistent phrase already in use throughout the Code.

Background

"Fastened in place" is used in the Code 58 times as follows"

Chapter 1: In addition to the CMP-12 definition it is used in the "Appliance" definition.

Chapter 2: 17 times, implies fixed and specifies (fixed) in a few places

Chapter 3: 19 times, prefaced with "securely" to make the phrase "securely fastened in place"; 20 times overall

Chapter 4: 1 time prefaced with "securely"; 2 times overall

Chapter 5: 2 times prefaced with "securely"; 6 times overall

Chapter 6: 5 times prefaced with "securely"; 10 times overall; the other 5 times in 625 (see below)

Chapter 8: 1 time prefaced with "securely"

The use of the phrase "securely fastened in place" is essentially the same definition that article 625 is applying to the term "fixed-in-place".

"Fixed in place" is used only 1 time in the CMP-12 portion of the Code and two other times in total – 1 in Chapter 5 and 1 in Chapter 7. A term that is only used

once does not require a definition since that same definition can be written in place of the term at the point of use. However, it is proposed to use the same phrase that is used 28 times in the Code to mean the same thing (securely fastened in place).

Related Public Comments for This Document

Related Comment

Relationship

[Public Comment No. 2033-NFPA 70-2024 \[Definition: Fastened-in-Place \(as applied to electric vehic...\)\]](#)

[Public Comment No. 2040-NFPA 70-2024 \[Definition: Fixed-in-Place \(as applied to electric vehicle ...\)\]](#)

[Public Comment No. 2048-NFPA 70-2024 \[Sections 625.44\(B\), 625.44\(C\)\]](#)

[Public Comment No. 2033-NFPA 70-2024 \[Definition: Fastened-in-Place \(as applied to electric vehic...\)\]](#)

[Public Comment No. 2040-NFPA 70-2024 \[Definition: Fixed-in-Place \(as applied to electric vehicle ...\)\]](#)

[Public Comment No. 2048-NFPA 70-2024 \[Sections 625.44\(B\), 625.44\(C\)\]](#)

Related Item

- PI-2460, 4230, 4231

Submitter Information Verification

Submitter Full Name: Karl Cunningham

Organization: Self Employed

Street Address:

City:

State:

Zip:

Submittal Date: Wed Aug 28 16:44:30 EDT 2024

Committee: NEC-P12

Substantiation for NEC 70 Comments for Fixed-in-place, Fastened-in-place

Public inputs regarding the CMP-12 definitions for “Fixed-in-place” and “Fastened-in-place” by two prominent Code trainers and commentators (PI-2460 by Mike Holt and PI-4230 and 4231 by Jeffrey Simpson) clearly display the confusion that exists in the public with these definitions (their Public Inputs were resolved due to their errant substantiation based on their misunderstanding). Though technically correct as is, these minor changes will simplify and clarify the Code by modifying the one term and using a consistent phrase already in use throughout the Code.

Background

“Fastened in place” is used in the Code 58 times as follows”

Chapter 1: In addition to the CMP-12 definition it is used in the “Appliance” definition.

Chapter 2: 17 times, implies fixed and specifies (fixed) in a few places

Chapter 3: 19 times, prefaced with “securely” to make the phrase “securely fastened in place”; 20 times overall

Chapter 4: 1 time prefaced with “securely”; 2 times overall

Chapter 5: 2 times prefaced with “securely”; 6 times overall

Chapter 6: 5 times prefaced with “securely”; 10 times overall; the other 5 times in 625 (see below)

Chapter 8: 1 time prefaced with “securely”

The use of the phrase “securely fastened in place” is essentially the same definition that article 625 is applying to the term “fixed-in-place”.

“Fixed in place” is used only 1 time in the CMP-12 portion of the Code and two other times in total – 1 in Chapter 5 and 1 in Chapter 7. A term that is only used once does not require a definition since that same definition can be written in place of the term at the point of use. However, it is proposed to use the same phrase that is used 28 times in the Code to mean the same thing (securely fastened in place).

Proposal to delete the highlighted/strikethrough words and add in the **green** words as follows:

Fixed-in-Place.

Mounting means of equipment using fasteners that require a tool for removal. (625) (CMP-12)

Delete

Fastened-in-Place.

Mounting means of equipment in which the fastening means are specifically designed to permit removal without the use of a tool. (625) (CMP-12)

Change definition to “Hand Fastened”

625.17(A) Power-Supply Cord.

The cable for cord-connected electric vehicle supply equipment (EVSE) shall comply with all of the following:

1. (1)

Be any of the types specified in [625.17\(B\)\(1\)](#) or hard service cord, junior hard service cord, or portable power cable types in accordance with [Table 400.4](#). Hard service cord, junior hard service cord, or portable power cable types shall be listed, as applicable, for exposure to oil and damp and wet locations.

2. (2)

Have an ampacity as specified in [Table 400.5\(A\)\(1\)](#) or, for 8 AWG and larger, in the 60°C (140°F) columns of [Table 400.5\(A\)\(2\)](#).

3. (3)

Have an overall length as specified in either of the following:

1. a.

When the interrupting device of the personnel protection system specified in [625.22](#) is located within the enclosure of the supply equipment or charging system, the power-supply cord shall be not more than the length indicated in (i) or (ii):

1. (i)

For portable equipment in accordance with [625.44\(A\)](#), the power-supply cord shall be not more than 300 mm (12 in.) long.

2. (ii)

For ~~fastened-in-place~~ hand fastened equipment in accordance with [625.44\(B\)](#), the power-supply cord shall be not more than 1.8 m (6 ft) long and the equipment shall be installed at a height that prevents the power-supply cord from contacting the floor when it is connected to the proper receptacle.

2. b.

When the interrupting device of the personnel protection system specified in [625.22](#) is located at the attachment plug, or within the first 300 mm (12 in.) of the power-supply cord, the overall cord length shall be not greater than 4.6 m (15 ft).

625.17(B) Output Cable to Electric Vehicles.

The output cable to electric vehicles shall be one of the following:

1. (1)

Listed Type EV, EVJ, EVE, EVJE, EVT, or EVJT flexible cable as specified in [Table 400.4](#)

2. (2)

An integral part of listed electric vehicle supply equipment
Informational Note No. 1: See UL 2594-2016, *Standard for Electric Vehicle Supply Equipment*, for information on conductive electric vehicle supply equipment.

Informational Note No. 2: See UL 2202-2009, *Standard for Electric Vehicle (EV) Charging System Equipment*, for information on conductive electric vehicle charging equipment.

625.17(C) Overall Cord and Cable Length.

The overall usable length shall not exceed 7.5 m (25 ft) unless equipped with a cable management system that is part of the listed electric vehicle supply equipment.

625.17(C)(1) Portable Equipment.

For portable EVSE, the cord-exposed usable length shall be measured from the face of the attachment plug to the face of the electric vehicle connector.

625.17(C)(2) Fastened-in-Place. Hand Fastened

Where the EVSE is ~~fastened-in-place~~, **hand fastened** the usable length of the output cable to the electric vehicle shall be measured from the cable exit of the electric vehicle supply equipment to the face of the electric vehicle connector.

Where the wireless power transfer equipment (WPTE) is fastened-in-place, the output cable to the primary pad shall be measured from the cable exit of the control box to the cable inlet at the primary pad.

625.44(B) Fastened-in-Place Hand Fastened Equipment.

Equipment that is fastened-in-place shall be connected to the premises wiring system by one of the following methods:

1. (1)

A nonlocking, 2-pole, 3-wire grounding-type receptacle outlet rated 125 volts or 250 volts, single phase, up to 50 amperes

2. (2)

A nonlocking, 3-pole, 4-wire grounding-type receptacle outlet rated 250 volts, three phase, up to 50 amperes

3. (3)

A nonlocking, 3-pole, 4-wire grounding-type receptacle outlet rated 125/250 volts, single phase, 30, 50, or 60 amperes

4. (4)

A nonlocking, 2-pole, 3-wire grounding-type receptacle outlet rated 60 volts dc maximum, 15 or 20 amperes

625.44(C) Fixed-in-Place Securely Fastened in Place Equipment.

All other EVSE and WPTE shall be permanently wired and ~~fixed-in-place~~ securely fastened in place to the supporting surface.



Public Comment No. 1202-NFPA 70-2024 [Section No. 625.17(A)]

(A) Power-Supply Cord.

The cable for cord-connected electric vehicle supply equipment (EVSE) shall comply with all of the following:

- (1) Be any of the types specified in 625.17(B)(1) or hard service cord, junior hard service cord, or portable power cable types in accordance with Table 400.4. Hard service cord, junior hard service cord, or portable power cable types shall be listed, as applicable, for exposure to oil and damp and wet locations.
- (2) Be of a type and ampacity as specified in Table 400.5(A)(1) or of type specified in 625.17(B)(1) and considered to have same ampacity rating as equivalent gauge hard service cord in Table 400.5(A)(1). For 8 AWG and larger, the cable shall be permitted to be of a type as specified in Table 400.5(A)(2) with an ampacity as specified in the 60°C (140°F) column of Table 400.5(A)(2).
- (3) Have an overall length as specified in either of the following:
 - (4) When the interrupting device of the personnel protection system is located within the enclosure of the supply equipment or charging system, the power-supply cord shall be not more than the length indicated in either of the following:
 - (5) For portable equipment in accordance with 625.44(A), the power-supply cord shall be not more than 300 mm (12 in.) long.
 - (6) For fastened-in-place equipment in accordance with 625.44(B), the power-supply cord shall be not more than 1.8 m (6 ft) long and the equipment shall be installed at a height that prevents the power-supply cord from contacting the floor when it is connected to the proper receptacle.
 - (7) When the interrupting device of the personnel protection system is located at the attachment plug, or within the first 300 mm (12 in.) of the power-supply cord, the overall cord length shall be not greater than 4.6 m (15 ft).

Statement of Problem and Substantiation for Public Comment

This Comment is to expand the use of EV Cords for Supply Cords in the Revision of this section and to allow an ampacity rating for EV Type cables as referenced in 625.17(B)(1) when used as power supply cords. Currently the ampacity is not specified for EV cables used for power supply cables. The comparison is equivalent only to Hard Service type ampacity ratings in 400.5(A)(1). This equivalency will limit the ampacity to proper terminal and branch circuits requirements.

Related Item

- FR8346

Submitter Information Verification

Submitter Full Name: Megan Hayes

Organization: NEMA

Street Address:

City:

State:

Zip:

Submittal Date: Sat Aug 17 00:42:05 EDT 2024

Committee: NEC-P12



Public Comment No. 1678-NFPA 70-2024 [Section No. 625.17(A)]

(A) Power-Supply Cord.

The cable for cord-connected electric vehicle supply equipment (EVSE) shall comply with all of the following:

- (1) Be any of the types specified in 625.17(B)(1) or hard service cord, junior hard service cord, or portable power cable types in accordance with Table 400.4. Hard service cord, junior hard service cord, or portable power cable types shall be listed, as applicable, for exposure to oil and damp and wet locations.
- (2) Be of a type and ampacity as specified in Table 400.5(A)(1). For 8 AWG and larger, the cable shall be permitted to be of a type as specified in Table 400.5(A)(2) with an ampacity as specified in the 60°C (140°F) column of Table 400.5(A)(2).
- (3) Have an overall length as specified in either of the following:
 - (4) When the interrupting device of the personnel protection system is located within the enclosure of the supply equipment or charging system, the power-supply cord shall be not more than the length indicated in either of the following:
 - (5) For portable equipment in accordance with 625.44(A), the power

-

a.

- i. supply cord shall be

not more than 300 mm (12 in.) long.

a.

- i. a maximum of 50' in length for systems drawing up to 150 amps of current.
- ii. For fastened-in-place equipment in accordance with 625.44(B), the power-supply cord shall be not more than 1.8 m (6 ft) long and the equipment shall be installed at a height that prevents the power-supply cord from contacting the floor when it is connected to the proper receptacle.

- b. When the interrupting device of the personnel protection system is located at the attachment plug or within the first 300 mm (12 in.) of the power-supply cord, the overall cord length shall be not greater than 4.6 m (15 ft).

Statement of Problem and Substantiation for Public Comment

The limitations imposed by the current regulation under 625.17(A) concerning the allowable length of power supply cords are too stringent. The stipulated length is unreasonably short and primarily tailored to Level 1 charging equipment, which does not accommodate the needs of other evolving technologies in the market, such as DC fast charging. Onboard personnel protection systems are listed and readily available, and in no way become more or less effective at commonly used consumer cord lengths.

Furthermore, isolated DC fast charging systems do not require isolation monitoring systems on the power supply side of the circuit. Ground fault protection is required to be installed at the point of use receptacle or the branch circuit overcurrent protection of the feeder circuit per NEC 70, Art. 625.54. Therefore, no such requirement would be applied to the EVSE, and a longer power supply cord for portable equipment would satisfy the intent of the standard without compromising user safety.

Arguments for longer usable cable lengths include applications in industrial automotive, aerospace, and general aviation ground support equipment, such as tugs, tow motors, and carts. Extremely short cabling is a hindrance in many markets where fleet operations are affected by real-world limitations, particularly limited working space. Specifically in the EV aerospace sector, the wingspan of aircraft necessitates increased cord lengths to enable safe indoor charging, eliminating the need for non-standard extension cords, which pose additional risks to users.

Given the advancements in safety technology and the practical needs of various industries, I urge a reconsideration of the cord length restriction under 625.17(A). Allowing for longer power supply cords would support technological innovation and operational efficiency without compromising safety.

Related Item

- Public Input No. 1753-NFPA 70-2023 [Part II.]

Submitter Information Verification

Submitter Full Name: Bryan Seymour

Organization: Beta Technologies

Street Address:

City:

State:

Zip:

Submittal Date: Mon Aug 26 10:04:03 EDT 2024

Committee: NEC-P12



(A) Power-Supply Cord.

The cable for cord-connected electric vehicle supply equipment (EVSE) shall comply with all of the following:

- (1) Be any of the types specified in 625.17(B)(1) or hard service cord, junior hard service cord, or portable power cable types in accordance with Table 400.4. Hard service cord, junior hard service cord, or portable power cable types shall be listed, as applicable, for exposure to oil and damp and wet locations.
 - (2) ~~Be of a type and~~ The ampacity as specified in the following:
 - (3) ~~for types specified in 625.17(B)(1), have an ampacity as specified in Table 400.5(A)(1).~~
- ~~For~~
- (1) column A or B; or for 8 AWG and larger
- ~~the cable shall be permitted to be of a type as specified in~~
- (1) in the 60 °C (140 °F) column of Table 400.5(A)(2),
- ~~with an~~
- (1) ~~;~~ or
 - (2) for other types, their respective ampacity as specified in
- ~~the 60 °C (140 °F)~~
- (1) either Table 400.5(A)(1) column A or B, or in the 60 °C (140 °F) column of Table 400.5(A)(2).
- (4) Have an overall length as specified in either of the following:
 - (5) When the interrupting device of the personnel protection system is located within the enclosure of the supply equipment or charging system, the power-supply cord shall be not more than the length indicated in either of the following:
 - (6) For portable equipment in accordance with 625.44(A), the power-supply cord shall be not more than 300 mm (12 in.) long.
 - (7) For fastened-in-place equipment in accordance with 625.44(B), the power-supply cord shall be not more than 1.8 m (6 ft) long and the equipment shall be installed at a height that prevents the power-supply cord from contacting the floor when it is connected to the proper receptacle.
 - (8) When the interrupting device of the personnel protection system is located at the attachment plug, or within the first 300 mm (12 in.) of the power-supply cord, the overall cord length shall be not greater than 4.6 m (15 ft).

Additional Proposed Changes

File Name	Description	Approved
2024-07-30_625.17_A_.png	readable version of the proposal	

Statement of Problem and Substantiation for Public Comment

625.17(A) requirement is divided into three sections, (1) for cable type, (2) for ampacity and (3) for cable length. The first draft text in 625.17(A)(2) partially repeats the type requirement that is already specified in 625.17(A)(1), and creates further confusion.

For example, an EVSE manufacturer has decided to design a Type EV cable for use on both the output cable, as well as the power supply cord. They would be allowed to, per Article 625.17(A)(1). In determining the conductor size, assuming 10 AWG, they would use the ampacity Table 400.5(A)(1). With the first draft text, it reasonable to interpret that the Type EV cable will also need to be Type S, SJ SO etc., to satisfy 625.17(A)(2) first draft text of "type and ampacity", since Type EV* is not in the list shown in the table. This creates duplication and unnecessary testing for Type EV* cables.

In a scenario that the Type EV design is to use 8 AWG or larger, the first draft text would also mean that the Type EV cable needs to be Type SC, SCE, SCT, PPE, G etc. Type PPE, G, G-GC, and W are rated for 2000V application, while Type EV is 1000V (Type EV* ranges from 300V -1000V). In this case, which requirement should the EVSE manufacturer take? The 2000V rating will be an over-kill if the EVSE will never see that voltage, while the 1000V would mean it does not meet the requirement of Type PPE, G, G-GC or W.

The proposed changes will continue to define the ampacity requirement 625.17(A)(2), with added clarity that should the type specified in 625.17(B)(1) be used for input power cord, they would have to meet the ampacity/conductor size as specified Table 400.5(A)(1) or 400.5(A)(2). For other types, they would have to meet the respective ampacity/conductor size as specified in Table 400.5(A)(1) or 400.5(A)(2).

Related Item

- FR-8276

Submitter Information Verification

Submitter Full Name: Indra Wiryadinata

Organization: Tesla

Street Address:

City:

State:

Zip:

Submittal Date: Wed Jul 31 12:04:06 EDT 2024

Committee: NEC-P12

(A) Power-Supply Cord.

The cable for cord-connected electric vehicle supply equipment (EVSE) shall comply with all of the following:

- (1) Be any of the types specified in 625.17(B)(1) or hard service cord, junior hard service cord, or portable power cable types in accordance with Table 400.4. Hard service cord, junior hard service cord, or portable power cable types shall be listed, as applicable, for exposure to oil and damp and wet locations.
- (2) The ampacity as specified in the following:
 - (1) for types specified in 625.17(B)(1), have an ampacity as specified in Table 400.5(A)(1) column A or B, or for 8 AWG and larger in the 60°C (140°F) column of Table 400.5(A)(2); or
 - (2) for other types, their respective ampacity as specified in either Table 400.5(A)(1) column A or B, or in the 60°C (140°F) column of Table 400.5(A)(2).
- (3) Have an overall length as specified in either of the following:
 - a. When the interrupting device of the personnel protection system is located within the enclosure of the supply equipment or charging system, the power-supply cord shall be not more than the length indicated in either of the following:
 - i. For portable equipment in accordance with 625.44(A), the power-supply cord shall be not more than 300 mm (12 in.) long.
 - ii. For fastened-in-place equipment in accordance with 625.44(B), the power-supply cord shall be not more than 1.8 m (6 ft) long and the equipment shall be installed at a height that prevents the power-supply cord from contacting the floor when it is connected to the proper receptacle.
 - b. When the interrupting device of the personnel protection system is located at the attachment plug, or within the first 300 mm (12 in.) of the power-supply cord, the overall cord length shall be not greater than 4.6 m (15 ft).



Public Comment No. 1196-NFPA 70-2024 [Section No. 625.42]

625.42 Rating.

The service, feeder, and branch circuit supplying EVSE shall have sufficient rating to supply the load served, unless the overall rating of the installation can be limited through controls as permitted by 625.42(A) or 625.42(B).

(A) Energy Management System (EMS).

All EMS used to provide load management of EVSE shall comply with Article 130.30, Part II, and the maximum equipment load on a service, feeder, and branch circuit shall be the maximum load permitted by the EMS. The EMS shall be permitted to be integral to one piece of equipment or integral to a listed system consisting of more than one piece of equipment. When one or more pieces of equipment are provided with an integral load management control, the system shall be marked to indicate this control is provided.

Network residing software that directs and limits EVSE output shall be permitted to be used as an energy management system for fleets of three or more vehicles, provided that the software complies with all of the following:

- (1) Programming shall be based on fleet modeling, including assessments of vehicle loading, travel distance, efficiency, battery degradation, and environment.
- (2) The EMS shall communicate directly with EVSE and include communication failure alarm(s).
- (3) Loss of EMS communication shall not result in an EVSE load greater than the load permitted by the service, feeder, and branch circuit rating.

(B) EVSE with Adjustable Settings.

EVSE with a current adjustment setting shall be permitted if restricted access to the adjustment setting is accomplished by at least one of the methods permitted in 130.30 70 (6 B). If the adjusted current setting has an impact on the rating label, those changes shall be in accordance with manufacturer's instructions, and the adjusted current setting shall appear on the field-installed rating label in accordance with 110.21. EVSE as referenced shall be permitted to have a current rating that is equal to the adjusted current setting. For equipment other than self-adjusting, the current adjustment setting shall be set at the time of installation and shall only be readjusted by a qualified person.

Informational Note: An example of a current adjustment setting is an EVSE that has the capability of being set to a maximum of 80A but is adjusted to a 40A maximum output to match the 50A branch circuit supplying the EVSE.

Statement of Problem and Substantiation for Public Comment

Restricted access requirements surrounding the rating adjustment means was introduced in the 2020 NEC.

In the development of the 2023 NEC, the restricted access requirement (with modifications) remained through the second draft, but the second draft deleted the list of items that were considered restricted access because it was repeated in 750.30(C)(3). SCR-10 was created that added a reference to the new location of the list of items that were considered restricted access, but this new reference stated 750.30(C) and, not 750.70(C)(3) the specific new location of the list. Because of this lack of specificity, it is unclear in the 2023 NEC whether the restricted access requires meeting all of 750.70(C) or just 750.70(C)(3) as was originally required.

For the 2026 NEC, CMP-12 added the text "...the adjustment setting is accomplished by at least one of the methods permitted in..." in FR 8304 to clarify that the reference is to the list in referenced section.

CMP-13 moved some of the requirements referenced to Article 750, Part II in FR 8095. The CC then moved the Article 750 to 130 in FCR 218.

The PC attempts to improve clarity by specifically referencing the subdivision that contains list of restricted access means. Secondly, this PC maintains correlation by updating the section numbers to align with the rearrangements made by other committees.

Related Item

- FR8304

Submitter Information Verification

Submitter Full Name: Megan Hayes

Organization: NEMA

Street Address:

City:

State:

Zip:

Submittal Date: Fri Aug 16 23:55:18 EDT 2024

Committee: NEC-P12



Public Comment No. 642-NFPA 70-2024 [Section No. 625.42]

625.42 Rating.

The service, feeder, and branch circuit supplying EVSE shall have sufficient rating to supply the load served, unless the overall rating of the installation can be limited through controls as permitted by 625.42(A) or 625.42(B).

(A) Energy Management System (EMS).

All EMS used to provide load management of EVSE shall comply with 130.30, and the maximum equipment load on a service, feeder, and branch circuit shall be the maximum load permitted by the EMS. The EMS shall be permitted to be integral to one piece of equipment or integral to a listed system consisting of more than one piece of equipment. When one or more pieces of equipment are provided with an integral load management control, the system shall be marked to indicate this control is provided.

Network residing software that directs and limits EVSE output shall be permitted to be used as an energy management system for fleets of three or more vehicles, provided that the software complies with all of the following:

- (1) Programming shall be based on fleet modeling, including assessments of vehicle loading, travel distance, efficiency, battery degradation, and environment.
- (2) The EMS shall communicate directly with EVSE and include communication failure alarm(s).
- (3) Loss of EMS communication shall not result in an EVSE load greater than the load permitted by the service, feeder, and branch circuit rating.

(B) EVSE with Adjustable Settings.

EVSE with a current adjustment setting shall be permitted if restricted access to the adjustment setting is accomplished by at least one of the methods permitted in 130.30(C). If the adjusted current setting has an impact on the rating label, those changes shall be in accordance with manufacturer's instructions, and the adjusted current setting shall appear on the field-installed rating label in accordance with 110.21. EVSE as referenced shall be permitted to have a current rating that is equal to the adjusted current setting. For equipment other than self-adjusting, the current adjustment setting shall be set at the time of installation and shall only be readjusted by a qualified person.

Informational Note: An example of a current adjustment setting is an EVSE that has the capability of being set to a maximum of 80A but is adjusted to a 40A maximum output to match the 50A branch circuit supplying the EVSE.

Additional Proposed Changes

<u>File Name</u>	<u>Description</u>	<u>Approved</u>
CN_342.pdf		

Statement of Problem and Substantiation for Public Comment

NOTE: The following CC Note No. 342 appeared in the First Draft Report on First Revision No. 8304.

The requirements in this section should be revised to align the terminology with Article 130, Part II, "EMS with PCS", as determined by CMP 13.

Related Item

- First Revision No. 8304

Submitter Information Verification

Submitter Full Name: CC Notes

Organization: NEC Correlating Committee

Street Address:

City:

State:

Zip:

Submission Date: Fri Aug 02 08:55:25 EDT 2024

Committee: NEC-P12



Correlating Committee Note No. 342-NFPA 70-2024 [Section No. 625.42]

Submitter Information Verification

Committee: NEC-AAC

Submittal Date: Fri May 10 08:00:37 EDT 2024

Committee Statement

Committee Statement: The requirements in this section should be revised to align the terminology with Article 130, Part II, "EMS with PCS", as determined by CMP 13.

First Revision No. 8304-NFPA 70-2024 [Section No. 625.42]

Ballot Results

✔ **This item has passed ballot**

12 Eligible Voters

1 Not Returned

11 Affirmative All

0 Affirmative with Comments

0 Negative with Comments

0 Abstention

Not Returned

McDaniel, Roger D.

Affirmative All

Ayer, Lawrence S.

Bowmer, Trevor N.

Hickman, Palmer L.

Holub, Richard A.

Jackson, Peter D.

Kendall, David H.

Manche, Alan

Osborne, Robert D.

Porter, Christine T.

Schultheis, Timothy James

Williams, David A.



Public Comment No. 1492-NFPA 70-2024 [Section No. 625.42(A)]

(A) Energy Management System (EMS).

All EMS used to provide load management of EVSE shall comply with 130.30, and the maximum equipment load on a service, feeder, and branch circuit shall be the maximum load permitted by the EMS. The EMS shall be permitted to be integral to one piece of equipment or integral to a listed system consisting of more than one piece of equipment. When one or more pieces of equipment are provided with an integral load management control, the system shall be marked to indicate this control is provided.

Exception: Network residing software that directs and limits EVSE output shall be permitted to be used as an energy management system for fleets of three or more vehicles, provided that the software complies with all of the following: Programming shall be based on fleet modeling, including assessments of vehicle loading, travel distance, efficiency, battery degradation, and environment.

- ~~The EMS shall communicate directly with EVSE and include communication failure alarm(s).~~
- ~~Loss of EMS communication shall not result in an EVSE load greater than the load permitted by the service, feeder, and branch circuit rating.~~

Statement of Problem and Substantiation for Public Comment

The NFPA currently lacks authority over software and does not maintain a cybersecurity policy. Such alterations could seriously jeopardize the integrity of EV charging systems.

Related Item

- FR8304

Submitter Information Verification

Submitter Full Name: Joel Goergen

Organization: Cisco Systems, Inc.

Affiliation: Cisco Systems, Inc.

Street Address:

City:

State:

Zip:

Submittal Date: Fri Aug 23 15:18:08 EDT 2024

Committee: NEC-P12



Public Comment No. 1993-NFPA 70-2024 [Section No. 625.42(A)]

(A) Energy Management System (EMS).

All EMS used to provide load management of EVSE shall comply with 130 ~~Part I~~. ~~All EMS used to provide overload control of EVSE shall also comply with 130 Part II~~, and the ~~maximum equipment~~ load on a service, feeder, and branch circuit shall be ~~the maximum load permitted by the EMS determined in accordance with 120.7~~. The EMS shall be permitted to be integral to one piece of equipment or integral to a listed system consisting of more than one piece of equipment. When one or more pieces of equipment are provided with an integral load management control, the system shall be marked to indicate this control is provided.

Network residing software that directs and limits EVSE output shall be permitted to be used as an energy management system for fleets of three or more vehicles, provided that the software complies with all of the following:

- (1) Programming shall be based on fleet modeling, including assessments of vehicle loading, travel distance, efficiency, battery degradation, and environment.
- (2) The EMS shall communicate directly with EVSE and include communication failure alarm(s).
- (3) Loss of EMS communication shall not result in an EVSE load greater than the load permitted by the service, feeder, and branch circuit rating.

Statement of Problem and Substantiation for Public Comment

New sections 130 and 120.7 describe installation requirements and load calculations for EMS- and PCS-controlled loads in the NEC. The EVSE section addressing EMS (625.42(A)) should correctly point users to these new sections for compliance. Right now, that direction is incomplete (only pointing to 130.3), and it appears to over-write the load calculations described for PCS in 120.7. The proposed text clarifies that all EMS for EVSE should comply with Part I of 130, and that all EMS providing overload control for EVSE should also comply with Part II of 130 and that EMS/PCS loads are calculated using 120.7.

Related Item

- FR 8095, FR 8184, and Global FCR 218

Submitter Information Verification

Submitter Full Name: Brennan Less

Organization: LBNL

Street Address:

City:

State:

Zip:

Submittal Date: Wed Aug 28 14:34:44 EDT 2024

Committee: NEC-P12



Public Comment No. 714-NFPA 70-2024 [Section No. 625.42(A)]

(A) Energy Management System (EMS).

All EMS used to provide load management of EVSE shall comply with 130.30, and the maximum equipment load on a service, feeder, and branch circuit shall be the maximum load permitted by the EMS. The EMS shall be permitted to be integral to one piece of equipment or integral to a listed system consisting of more than one piece of equipment. When one or more pieces of equipment are provided with an integral load management control, the system shall be marked to indicate this control is provided.

Network residing software that directs and limits EVSE output shall be permitted to be used as an energy management system for fleets of three or more vehicles, provided that the software complies with all of the following:

- (1) Programming shall be based on fleet modeling, ~~including assessments~~ for example assessments of vehicle loading, travel distance, efficiency, battery degradation, and environment.
- (2) The EMS shall communicate directly with EVSE and include communication failure alarm(s).
- (3) Loss of EMS communication shall not result in an EVSE load greater than the load permitted by the service, feeder, and branch circuit rating.

Statement of Problem and Substantiation for Public Comment

Replaced "including" to "for example" to expand the scope of fleet modelling assessment. The use of "including" means that if fleet assessment does not contain any of the five specified parameters, it does not meet the criteria of 625.42(A)(1), hence not a network residing EMS software. This is too restrictive, and hinders development for future modelling that may use fewer parameters and provide equal or better accuracy.

Related Item

- PI-655

Submitter Information Verification

Submitter Full Name: Indra Wiryadinata

Organization: Tesla

Street Address:

City:

State:

Zip:

Submittal Date: Fri Aug 02 15:58:58 EDT 2024

Committee: NEC-P12



Public Comment No. 1833-NFPA 70-2024 [Section No. 625.42(B)]

(B) EVSE with Adjustable Settings.

EVSE with a current adjustment setting shall be permitted if restricted access to the adjustment setting is accomplished by at least one of the methods permitted in 130.30(C) - If the adjusted current setting has an impact on the rating label, those changes shall be in accordance with manufacturer's instructions, and the adjusted current setting shall appear on be applied to the field-installed rating label in accordance with 110.21.- EVSE as referenced shall be permitted to have a current rating that is equal to the adjusted current setting. For equipment other than self-adjusting, the current. The current adjustment setting shall be set at the time of installation and shall only be readjusted by a qualified person. The installer must ensure that sufficient documentation is left permanently attached to or within the EVSE, such that a future worker can validate the setpoint and understand the full range of setpoints available while physically at the equipment. If the EVSE supports separate per-unit current and total limits, those settings must be made via distinct switches or other means.

Informational Note: An example of a current adjustment setting is an EVSE that has the capability of being set to a maximum of 80A but is adjusted to a 40A maximum output to match the 50A branch circuit supplying the EVSE.

Statement of Problem and Substantiation for Public Comment

These changes are substantiated or justified based on:

Section 130.30(C) no longer has any restrictions.

Section 120.57 handles load calculations.

Some of the wording had no practical effect, so was removed.

I work as an inspector in part, and the most important thing is to be able to field verify an installation. This is challenging with a PCS, please help us inspectors do our job. During an inspection people in my line of work typically look at breaker sizes, equipment rating labels, verify the wire size printed in tiny letters on cables. Thus, it is core to our job to be able to validate an electrical panel and installation from visual inspection alone. Typically, we won't have access to any installation manuals or plans or websites.

Especially in the EVSE space, companies may cease business operation or discontinue products. Thus, the request to make the load adjustment settings self-documenting. Vendors could accomplish this with labels on the printed circuit board near adjustment switches, a small insert with documentation, or on the label. If the vendor does not do this, then I ask that the installer be required to supply durable documentation for the benefit of those who will service the equipment next.

If an app is required, the name of the app at the very least should be disclosed, but frankly it's way better if it's a permanent switch that can't be messed with or hacked. Cybersecurity issues are real, especially for devices like EVSE that are produced in high volume by companies that may cease support, and where electrical safety is involved.

Related Public Comments for This Document

<u>Related Comment</u>	<u>Relationship</u>
Public Comment No. 1740-NFPA 70-2024 [Section No. 625.2]	
Public Comment No. 1850-NFPA 70-2024 [Definition: Example D15(b) Monitoring Controlled and Noncon...]	
<u>Related Item</u>	
• Public Input No. 1829-NFPA 70-2023 [Section No. 750.30(C)]	• Public Input No. 4293-NFPA 70-2023 [Section No. 750.30(C)(3)]
	• Public Input No. 2689-NFPA 70-2023 [Section No. 625.42(B)]

Submitter Information Verification

Submitter Full Name: Bryce Nesbitt
Organization: Obviously Inspects / Expert Witness / Permit and Entitlement Consultant
Affiliation: Self
Street Address:
City:
State:
Zip:
Submittal Date: Tue Aug 27 16:21:35 EDT 2024
Committee: NEC-P12



Public Comment No. 887-NFPA 70-2024 [Section No. 625.42(B)]

(B) EVSE with Adjustable Settings.

EVSE with a current adjustment setting shall be permitted if restricted access to the adjustment setting is accomplished by at least one of the methods permitted in ~~130.36~~ 70 (E). If the adjusted current setting has an impact on the rating label, those changes shall be in accordance with manufacturer's instructions, and the adjusted current setting shall appear on the field-installed rating label in accordance with 110.21. EVSE as referenced shall be permitted to have a current rating that is equal to the adjusted current setting. For equipment other than self-adjusting, the current adjustment setting shall be set at the time of installation and shall only be readjusted by a qualified person.

Informational Note: An example of a current adjustment setting is an EVSE that has the capability of being set to a maximum of 80A but is adjusted to a 40A maximum output to match the 50A branch circuit supplying the EVSE.

Statement of Problem and Substantiation for Public Comment

130.70(B) is the appropriate section that defines restricted access.

Related Item

- FR-8304

Submitter Information Verification

Submitter Full Name: Indra Wiryadinata

Organization: Tesla

Street Address:

City:

State:

Zip:

Submittal Date: Wed Aug 07 12:22:24 EDT 2024

Committee: NEC-P12



625.43 Disconnecting Means.

EVSE and WPTE, shall be provided with one or more disconnecting means in accordance with 625.43(A) and 625.43(B).

(A) Equipment Disconnects.

For permanently connected EVSE and WPTE, a disconnecting means shall be provided and installed in a readily accessible location. The disconnecting means shall be lockable open in accordance with 110.25 . If the disconnecting means is installed remote from the equipment, a plaque or directory shall be installed on the equipment denoting the location of the disconnecting means. For cord- and plug-connected EVSE and WPTE, with a rating not exceeding 60 amperes or not exceeding 150 volts to ground, the cord and plug shall be permitted to serve as the disconnecting means. ~~The disconnecting means shall be lockable open in accordance with 110.25 .~~

(B) Emergency Shutoff.

For ~~other than one- and two-family dwellings,~~ permanently connected EVSE and WPTE, one or more clearly identified emergency disconnect devices or electrical disconnects shall be provided and shall meet all of the following:

~~Be marked "EVSE EMERGENCY DISCONNECT"~~

- (1) ~~Be installed. Installed in a~~ readily accessible location ~~in sight from the equipment~~
- (2) ~~Disconnect power to all EVSE and WPTE within sight of emergency shutoff~~
- (3) ~~, no less than 6 m (20 ft) or more than 30 m (100 feet), and visible to the EVSE and WPTE.~~
- (4)
- (5) ~~Marked "EV CHARGING EQUIPMENT EMERGENCY DISCONNECT" and "WARNING ELECTRIC VEHICLE(S) WILL REMAIN ENERGIZED" in accordance with 110.22(A)~~

~~Be a manual reset type~~

~~Markings shall comply with both of the following:~~

- ~~1. The markings shall be located on the outside front of the disconnect enclosure with a red background and white text.~~
- ~~2. The letters shall be at least 13mm (1/2 in.) high.~~

- (1) ~~Incorporate a manual reset~~
- (2) Disconnect all ungrounded conductors of the circuits simultaneously from the source of supply
- (3) ~~For one- and two-family dwellings, permanently connected EVSE and WPTE with power export functionality shall comply with 706.15.~~

The disconnecting means required in accordance with 625.43(A) shall be permitted to serve as the emergency disconnect if it complies with all the requirements of 625.43(B).

Additional Proposed Changes

<u>File Name</u>	<u>Description</u>	<u>Approved</u>
625.43.docx	625.43 Legislative Format	

Statement of Problem and Substantiation for Public Comment

This public comment was created by a Joint Task Group made up of members for NEMA EVSE and LVDE Sections, and representatives from the Big City Fire Working Group and intended to revise 625.43 per FR 8317.

The reference to 110.25 was moved for clarity and usability.

A 6 m (20 ft) minimum distance is required for the Emergency Disconnect to provide a safe distance in case of a vehicle fire. A 30m (100ft) maximum distance was used to ensure that the Emergency Disconnects is visible to the equipment.

The marking requirement was expanded to make it clear that the Emergency Disconnect only de-energizes the EVSE or WPTE and that the EV vehicle is still energized.

One- and two-family dwellings are exempt for this Emergency Shutoff since 230.85 requires Emergency Disconnects for the Service in one- and two-family dwellings.

6) was added to correlate with 706.15 that requires emergency shutdown feature for EV charging equipment that can export power from one- and two-family dwellings.

Other editorial revisions were made for clarity and usability. Subsection .43 B (2) was removed as it is redundant to the editorial changes in .43 B (1)

Related Item

- FR8317

Submitter Information Verification

Submitter Full Name: Megan Hayes
Organization: NEMA
Street Address:
City:
State:
Zip:
Submittal Date: Sat Aug 17 04:41:28 EDT 2024
Committee: NEC-P12

625.43 Disconnecting Means.

EVSE and WPTE, shall be provided with one or more disconnecting means in accordance with 625.43(A) and 625.43(B).

(A) Equipment Disconnects.

For permanently connected EVSE and WPTE, a disconnecting means shall be provided and installed in a readily accessible location. The disconnecting means shall be lockable open in accordance with 110.25.

If the disconnecting means is installed remote from the equipment, a plaque or directory shall be installed on the equipment denoting the location of the disconnecting means. For cord- and plug-connected EVSE and WPTE, with a rating not exceeding 60 amperes or not exceeding 150 volts to ground, the cord and plug shall be permitted to serve as the disconnecting means. The disconnecting means shall be lockable open in accordance with 110.25.

(B) Emergency Shutoff.

For other than one- and two-family dwellings, permanently connected EVSE and WPTE, one or more clearly identified emergency disconnect devices or electrical disconnects shall be provided and shall meet all of the following:

~~(1) Be installed in a readily accessible location, in sight no less than 6 m (20 ft) or more than 30 m (100 feet), and visible to from the equipment EVSE and WPTE.~~

~~(2) Disconnect power to all EVSE and WPTE within sight of emergency shutoff~~

~~(2) Be marked "EV_SE-CHARGING EQUIPMENT EMERGENCY DISCONNECT" and "WARNING ELECTRIC VEHICLE(S) WILL REMAIN ENERGIZED" in accordance with 110.22(A)~~

~~(3)~~
Markings shall comply with both of the following:

1. The markings shall be located on the outside front of the disconnect enclosure with a red background and white text.
2. The letters shall be at least 13mm (1/2 in.) high.

~~(4)~~(3) Be incorporate a manual reset type

~~(4) Disconnect all ungrounded conductors of the circuits simultaneously from the source of supply~~

~~(5) For one- and two-family dwellings, permanently connected EVSE and WPTE with power export functionality shall comply with 706.15.~~

Formatted: Font: (Default) Arial, 12 pt

Formatted: Indent: Left: 0.5", Space After: 8 pt, Line spacing: Multiple 1.08 li, No bullets or numbering

Formatted: Font: (Default) Arial, 12 pt

Formatted: List Paragraph, Indent: Left: 0.75"

Formatted: Font: (Default) Arial, 12 pt

Formatted: Indent: Left: 0.5", Space After: 8 pt, Line spacing: Multiple 1.08 li, No bullets or numbering

The disconnecting means required in accordance with 625.43(A) shall be permitted to serve as the emergency disconnect if it complies with all the requirements of 625.43(B).



Public Comment No. 1909-NFPA 70-2024 [Section No. 625.43]

625.43 Disconnecting Means.

~~EVSE and WPTE, shall be provided with one or more disconnecting means in accordance with 625.43(A) and 625.43(B) :~~

~~(A) Equipment Disconnects.~~

~~For permanently connected EVSE- and WPTE , a disconnecting means shall be provided and installed in a readily accessible location. If the disconnecting means is installed remote from the equipment, a plaque or directory shall be installed on the equipment denoting the location of the disconnecting means. For cord- and plug-connected EVSE- and WPTE , with a rating not exceeding 60 amperes or not exceeding 150 volts to ground, the cord and plug shall be permitted to serve as the disconnecting means. The disconnecting means shall be lockable open in accordance with 110.25.~~

~~(B) Emergency Shutoff.~~

~~For permanently connected EVSE and WPTE, one or more clearly identified emergency disconnect devices or electrical disconnects shall be provided and shall meet all of the following:~~

- ~~(1) Be installed in a readily accessible location in sight from the equipment~~
- ~~(2) Disconnect power to all EVSE and WPTE within sight of emergency shutoff~~
- ~~(3) Be marked "EVSE EMERGENCY DISCONNECT" in accordance with 410.22(A)~~
- ~~(4) Be a manual reset type~~
- ~~(5) Disconnect all ungrounded conductors of the circuits simultaneously from the source of supply~~

~~The disconnecting means required in accordance with 625.43(A) shall be permitted to serve as the emergency disconnect if it complies with all the requirements of 625.43(B) : For sites with EVSE fed from more than one service, plaques and/or color coding shall clearly indicate which equipment is downstream of the given disconnecting means.~~

Statement of Problem and Substantiation for Public Comment

WPTE are a type of Electrical Vehicle Service Equipment, and I suggest that it's better to reserve use the acronym WPTE for sections of the code where the distinction is important. WPTE should be held to all standards for EVSE, other than those specific to their wireless nature.

As written the shutoffs in this section are a fine match for highway public charging stations, but a poor match for apartments and multi-family buildings.

Given "625.43(A) shall be permitted to serve as the emergency disconnect if it complies with all the requirements of 625.43(B)" it appears the disconnect can no longer be remote from the fixed in place equipment. Section (A) is overruled by 625.43(B)(1).

Yet having multiple disconnects on a single circuit is confusing and fragile in an apartment garage or parking lot. Vandalism, vehicle impact damage, abuse, and/or "gefingerpoken" is common in multifamily. The less operable stuff in apartment garages areas that can be played with the better. It's better to have a single bank of disconnects at the mains where a security camera at least can cover the area.

This is especially true as some vehicles will lock the EVSE in place if power fails, meaning an affected EV driver may be left without transportation until the confusion is cleared up. In my view a plaque and a lockout are sufficient for the infrequent internal electrical servicing needs of EVSE in such settings.

In small to medium multifamily it's rare to have accurate drawings of the locations of equipment, and it's just way easier to have the shutoff centralized. For large installations the plaque approach provides good certainty of which disconnect does what, helping EMS personnel make the correct shutoffs.

Related Item

- Public Input No. 232-NFPA 70-2023 [Section No. 625.43]

Submitter Information Verification

Submitter Full Name: Bryce Nesbitt

Organization: Obviously Inspects

Street Address:

City:

State:

Zip:

Submittal Date: Wed Aug 28 02:41:53 EDT 2024

Committee: NEC-P12



Public Comment No. 1940-NFPA 70-2024 [Section No. 625.43]

625.43 Disconnecting Means.

EVSE and WPTE, shall be provided with one or more disconnecting means in accordance with 625.43(A) and 625.43(B).

(A) Equipment Disconnects.

For permanently connected EVSE and WPTE, a disconnecting means shall be provided and installed in a readily accessible location. The disconnecting means shall be lockable open in accordance with 110.25. If the disconnecting means is installed remote from the equipment, a plaque or directory shall be installed on the equipment denoting the location of the disconnecting means. For cord- and plug-connected EVSE and WPTE, with a rating not exceeding 60 amperes or not exceeding 150 volts to ground, the cord and plug shall be permitted to serve as the disconnecting means. ~~The disconnecting means shall be lockable open in accordance with 110.25.~~

(B) Emergency Shutoff.

For ~~other than one- and two-family dwellings~~, permanently connected EVSE and WPTE, one or more clearly identified emergency disconnect devices or electrical disconnects shall be provided and shall meet all of the following:

~~Be marked "EVSE EMERGENCY DISCONNECT"~~

- (1) ~~Be installed~~ Installed in a readily accessible location ~~in sight from the equipment~~
- (2) ~~Disconnect power to all EVSE and WPTE within sight of emergency shutoff~~
- (3) , no less than 6 m (20 ft) or more than 30 m (100 feet), and visible to the EVSE and WPTE.
- (4) Marked "EV-CHARGING EQUIPMENT EMERGENCY DISCONNECT" and "WARNING ELECTRIC VEHICLE(S) WILL REMAIN ENERGIZED" in accordance with 110.22(A)

~~Be a~~

Markings shall comply with both of the following:

(a) The markings shall be located on the outside front of the disconnect enclosure with red background and white text.

(b) The letters shall be at least 13 mm (1/2 in.) high.

(4) Incorporate a manual reset type

(5) Disconnect all ungrounded conductors of the circuits simultaneously from the source of supply.

(6) For one- and two-family dwellings, permanently connected EVSE and WPTE with power export functionality shall comply with 706.15.

The disconnecting means required in accordance with 625.43(A) shall be permitted to serve as the emergency disconnect if it complies with all the requirements of 625.43(B).

Statement of Problem and Substantiation for Public Comment

This is my personal attempt to enter this revision approved by NEMA. NEMA (PC 1216) was Terra Attacked while entering the revision and I was trying to make it clearer, however, Terra still did some funky things. As a CMP-12 representative, I am available for clarifications' and questions.

NEMA's Substantiation:

This public comment was created by a Joint Task Group made up of members for NEMA EVSE and LVDE Sections, and representatives from the Big City Fire Working Group and intended to revise 625.43 per FR 8317.

The reference to 110.25 was moved for clarity and useability.

A 6 m (20 ft) minimum distance is required for the Emergency Disconnect to provide a safe distance in case of a vehicle fire. A 30m (100ft) maximum distance was used to ensure that the Emergency Disconnects is visible to the equipment. See attached 6A 2010 05 Safety advisory, DOE, Office of Health, Safety and Security.

The marking requirement was expanded to make it clear that the Emergency Disconnect only de-energizes the EVSE or WPTE and that the EV vehicle is still energized.

One and two family dwellings are exempt for this Emergency Shutoff since 230.85 requires Emergency Disconnects for the Service in one and two family dwellings.

6) was added to correlate with 706.15 that requires emergency shutdown feature for EV charging equipment that can export power from one and two family dwellings.

Other editorial revisions were made for clarity and useability. Subsection .43 B(2) was removed as it is redundant to the editorial changes in .43 B(1)

Related Item

• FR 8317 • PC 1216

Submitter Information Verification

Submitter Full Name: David Kendall

Organization: ABB Inc.

Street Address:

City:

State:

Zip:

Submittal Date: Wed Aug 28 11:46:36 EDT 2024

Committee: NEC-P12



Public Comment No. 2011-NFPA 70-2024 [Section No. 625.43]

625.43 Disconnecting Means.

EVSE and WPTE, shall be provided with one or more disconnecting means in accordance with 625.43(A) ~~and 625.43(B)~~.

(A) Equipment Disconnects.

For permanently connected EVSE and WPTE, a disconnecting means shall be provided and installed in a readily accessible location. If the disconnecting means is installed remote from the equipment, a plaque or directory shall be installed on the equipment denoting the location of the disconnecting means. For cord- and plug-connected EVSE and WPTE, with a rating not exceeding 60 amperes or not exceeding 150 volts to ground, the cord and plug shall be permitted to serve as the disconnecting means. The disconnecting means shall be lockable open in accordance with 110.25.

~~**(B) Emergency Shutoff.**~~

~~For permanently connected EVSE and WPTE, one or more clearly identified emergency disconnect devices or electrical disconnects shall be provided and shall meet all of the following:~~

- ~~(1) Be installed in a readily accessible location in sight from the equipment~~
- ~~(2) Disconnect power to all EVSE and WPTE within sight of emergency shutoff~~
- ~~(3) Be marked "EVSE EMERGENCY DISCONNECT" in accordance with 410.22(A)~~
- ~~(4) Be a manual reset type~~
- ~~(5) Disconnect all ungrounded conductors of the circuits simultaneously from the source of supply~~

~~The disconnecting means required in accordance with 625.43(A) shall be permitted to serve as the emergency disconnect if it complies with all the requirements of 625.43(B).~~

Statement of Problem and Substantiation for Public Comment

By requiring emergency shutdown equipment for hardwired EVSE the cost of such installation will be much higher than cord and plug EVSE. This will lead to the preference of cord and plug EVSE which are inherently less safe due to potentially exposed conductors in a partially mated connector as well as overheating issues in the receptacle. There have already been numerous incidents of melted receptacles, so much so that Tesla has adopted thermal sensing in the NEMA connector. No other equipment commonly installed in private residences has such high standard for emergency shutdown. Common heat pumps or other HVAC systems use similar power but have no such requirements.

[Related Item](#)

- Public Input No. 3106-NFPA 70-2023 [Section No. 625.43]

Submitter Information Verification

Submitter Full Name: Armin Karcher

Organization: N/A

Street Address:

City:

State:

Zip:

Submittal Date: Wed Aug 28 15:26:28 EDT 2024

Committee: NEC-P12



Public Comment No. 2032-NFPA 70-2024 [Section No. 625.43]

625.43 Disconnecting Means.

EVSE and WPTE, shall be provided with one or more disconnecting means in accordance with 625.43(A) and 625.43(B).

(A) Equipment Disconnects.

For permanently connected EVSE and WPTE, a disconnecting means shall be provided and installed in a readily accessible location. If the disconnecting means is installed remote from the equipment, a plaque or directory shall be installed on the equipment denoting the location of the disconnecting means. For cord- and plug-connected EVSE and WPTE, with a rating not exceeding 60 amperes or not exceeding 150 volts to ground, the cord and plug shall be permitted to serve as the disconnecting means. The disconnecting means shall be lockable open in accordance with 110.25.

(B) Emergency Shutoff.

~~For permanently connected EVSE and WPTE, one or more clearly identified emergency disconnect devices or electrical disconnects shall be provided and shall meet all of the following:~~

- ~~(1) Be installed in a readily accessible location in sight from the equipment~~
- ~~(2) Disconnect power to all EVSE and WPTE within sight of emergency shutoff~~
- ~~(3) Be marked "EVSE EMERGENCY DISCONNECT" in accordance with 410.22(A)~~
- ~~(4) Be a manual reset type~~
- ~~(5) Disconnect all ungrounded conductors of the circuits simultaneously from the source of supply~~

~~The disconnecting means required in accordance with 625.43(A) shall be permitted to serve as the emergency disconnect if it complies with all the requirements of 625.43(B).~~

Statement of Problem and Substantiation for Public Comment

Residential EVSE needs no regular service, and therefore the prior code language provisions for lockouts in the general vicinity seem fully sufficient to allow for efficient service on the rare occasion that it is necessary.

This proposed requirement is a poor match for apartment and condominium parking areas. Scattering disconnects through an underground parking garage or outside flat parking area to meet the line of sight requirement will increase the number of potential failure points, open the disconnects to damage, lead to confusion when EVSEs do not work, while adding significant installation costs. For apartments and condominiums the existing centralization of the disconnects at the panel, with appropriate lockouts, makes more financial and operational sense. For single family homes this requirement is completely unnecessary, as the owner/operator will know where the breakers are located. Finally, for mechanical access parking garages with sliding equipment, this requirement may well be infeasible.

Related Item

- First Revision No. 8317-NFPA 70-2024 [Section No. 625.43]

Submitter Information Verification

Submitter Full Name: Sven Thesen
Organization: EVCAC
Affiliation: Electric Vehicle Charging for All Coalition, Co-Lead
Street Address:
City:
State:
Zip:
Submittal Date: Wed Aug 28 16:21:39 EDT 2024
Committee: NEC-P12



Public Comment No. 2077-NFPA 70-2024 [Section No. 625.43]

625.43 Disconnecting Means.

EVSE and WPTE, shall be provided with one or more disconnecting means in accordance with 625.43(A) and 625.43(B).

(A) Equipment Disconnects.

For permanently connected EVSE and WPTE, a disconnecting means shall be provided and installed in a readily accessible location. If the disconnecting means is installed remote from the equipment, a plaque or directory shall be installed on the equipment denoting the location of the disconnecting means. For cord- and plug-connected EVSE and WPTE, with a rating not exceeding 60 amperes or not exceeding 150 volts to ground, the cord and plug shall be permitted to serve as the disconnecting means. The disconnecting means shall be lockable open in accordance with 110.25.

~~**(B) Emergency Shutoff.**~~

~~For permanently connected EVSE and WPTE, one or more clearly identified emergency disconnect devices or electrical disconnects shall be provided and shall meet all of the following:~~

- ~~(1) Be installed in a readily accessible location in sight from the equipment~~
- ~~(2) Disconnect power to all EVSE and WPTE within sight of emergency shutoff~~
- ~~(3) Be marked "EVSE EMERGENCY DISCONNECT" in accordance with 410.22(A)~~
- ~~(4) Be a manual reset type~~
- ~~(5) Disconnect all ungrounded conductors of the circuits simultaneously from the source of supply~~

~~The disconnecting means required in accordance with 625.43(A) shall be permitted to serve as the emergency disconnect if it complies with all the requirements of 625.43(B).~~

Statement of Problem and Substantiation for Public Comment

This proposed code change does not take into account the multitude of situations that EVSE may be installed. Keeping a disconnect in the line of sight of a multifamily parking, public parking garages and lots could lead to tampering and endanger curious children. Disconnects should remain in mechanical rooms, electrical rooms and areas separated from the general public.

Having multiple disconnects would lead to confusion as well, in case one or the other ever was turned off, and a poor user experience (including potentially the inability to charge or move a car).

The second draft language seems inappropriate for residential use, including multifamily garages. Existing labeling requirements for equipment at highway commercial and industrial charging sites seem like they would cover appropriate labeling requirements.

Related Item

- First Revision No. 8317-NFPA 70-2024 [Section No. 625.43]

Submitter Information Verification

Submitter Full Name: Paul Nijssen

Organization: EVCHARGE4U INC

Street Address:

City:

State:

Zip:

Submittal Date: Wed Aug 28 18:16:36 EDT 2024

Committee: NEC-P12



Public Comment No. 644-NFPA 70-2024 [Section No. 625.43]

625.43 Disconnecting Means.

EVSE and WPTE, shall be provided with one or more disconnecting means in accordance with 625.43(A) and 625.43(B).

(A) Equipment Disconnects.

For permanently connected EVSE and WPTE, a disconnecting means shall be provided and installed in a readily accessible location. If the disconnecting means is installed remote from the equipment, a plaque or directory shall be installed on the equipment denoting the location of the disconnecting means. For cord- and plug-connected EVSE and WPTE, with a rating not exceeding 60 amperes or not exceeding 150 volts to ground, the cord and plug shall be permitted to serve as the disconnecting means. The disconnecting means shall be lockable open in accordance with 110.25.

(B) Emergency Shutoff.

For permanently connected EVSE and WPTE, one or more clearly identified emergency disconnect devices or electrical disconnects shall be provided and shall meet all of the following:

- (1) Be installed in a readily accessible location in sight from the equipment
- (2) Disconnect power to all EVSE and WPTE within sight of emergency shutoff
- (3) Be marked "EVSE EMERGENCY DISCONNECT" in accordance with 110.22(A)
- (4) Be a manual reset type
- (5) Disconnect all ungrounded conductors of the circuits simultaneously from the source of supply

The disconnecting means required in accordance with 625.43(A) shall be permitted to serve as the emergency disconnect if it complies with all the requirements of 625.43(B).

Additional Proposed Changes

<u>File Name</u>	<u>Description</u>	<u>Approved</u>
CN_343.pdf		

Statement of Problem and Substantiation for Public Comment

NOTE: The following CC Note No. 343 appeared in the First Draft Report on First Revision No. 8317.

CMP 12 should consider First Revision 8975, and the deletion of the defined term. It may be preferable to refer to the requirement in 110.29 (for usability), unless the defined term is restored by CMP1.

The first revision by CMP1 to remove the defined term "in sight from (within sight from)(within sight)" may make application of 625.43(B) more difficult to enforce without the reference to the requirement in 110.29.

Related Item

- First Revision No. 8317

Submitter Information Verification

Submitter Full Name: CC Notes
Organization: NEC Correlating Committee
Street Address:
City:
State:
Zip:
Submittal Date: Fri Aug 02 08:57:24 EDT 2024
Committee: NEC-P12



Correlating Committee Note No. 343-NFPA 70-2024 [Section No. 625.43]

Submitter Information Verification

Committee: NEC-AAC

Submittal Date: Fri May 10 08:03:11 EDT 2024

Committee Statement

Committee Statement: CMP 12 should consider First Revision 8975, and the deletion of the defined term. It may be preferable to refer to the requirement in 110.29 (for usability), unless the defined term is restored by CMP1.

The first revision by CMP1 to remove the defined term “in sight from (within sight from)(within sight)” may make application of 625.43(B) more difficult to enforce without the reference to the requirement in 110.29.

[First Revision No. 8317-NFPA 70-2024 \[Section No. 625.43\]](#)

Ballot Results

✓ **This item has passed ballot**

12 Eligible Voters

1 Not Returned

11 Affirmative All

0 Affirmative with Comments

0 Negative with Comments

0 Abstention

Not Returned

McDaniel, Roger D.

Affirmative All

Ayer, Lawrence S.

Bowmer, Trevor N.

Hickman, Palmer L.

Holub, Richard A.

Jackson, Peter D.

Kendall, David H.

Manche, Alan

Osborne, Robert D.

Porter, Christine T.

Schultheis, Timothy James

Williams, David A.



Public Comment No. 553-NFPA 70-2024 [Section No. 625.43(A)]

(A) Equipment Disconnects.

For permanently connected EVSE and WPTE, a disconnecting means shall be provided and installed in a readily accessible location. The disconnecting means shall be lockable open in accordance with 110.25. If the disconnecting means is installed remote from the equipment, a plaque or directory shall be installed on the equipment denoting the location of the disconnecting means. For cord- and plug-connected EVSE and WPTE, with a rating not exceeding 60 amperes or not exceeding 150 volts to ground, the cord and plug shall be permitted to serve as the disconnecting means. ~~The disconnecting means shall be lockable open in accordance with 110.25.~~

Statement of Problem and Substantiation for Public Comment

Move lockable means requirement to be for permanently connected EVSE, not after the cord and plug requirement.

Related Item

- FR-8317

Submitter Information Verification

Submitter Full Name: Indra Wiryadinata

Organization: Tesla

Street Address:

City:

State:

Zip:

Submittal Date: Wed Jul 31 12:28:50 EDT 2024

Committee: NEC-P12



Public Comment No. 807-NFPA 70-2024 [Section No. 625.43(A)]

(A) Equipment Disconnects.

For permanently connected EVSE and WPTE, a disconnecting means shall be provided and installed in a readily accessible location. If the disconnecting means is installed remote from the equipment, a plaque or directory shall be installed on the equipment denoting the location of the disconnecting means. ~~For~~ The disconnecting means shall be lockable open in accordance with 110.25. ~~For~~ cord- and plug-connected EVSE and WPTE, with a rating not exceeding 60 amperes or not exceeding 150 volts to ground, the cord and plug shall be permitted to serve as the disconnecting means. ~~The disconnecting means and shall not be lockable open in accordance with 110.25~~ : required to be lockable.

Statement of Problem and Substantiation for Public Comment

Although Terraview made it quite difficult to read, this comment is intended to move (First Draft) last sentence in front of the language regarding cord-and-plug connections. It also adds language indicating that such a connection need not be lockable. As written in the first draft, it appears that a cord-and-plug connection needs to be lockable, although I do not believe that to be the intent.

Related Item

- FR 8317

Submitter Information Verification

Submitter Full Name: Ryan Jackson

Organization: Self-employed

Street Address:

City:

State:

Zip:

Submittal Date: Mon Aug 05 15:24:21 EDT 2024

Committee: NEC-P12



Public Comment No. 1785-NFPA 70-2024 [Section No. 625.43(B)]

(B) Emergency Shutoff.

For permanently connected EVSE and WPTE, one or more clearly identified emergency disconnect devices or electrical disconnects shall be provided and shall meet all of the following:

- (1) Be installed in a readily accessible location in sight from the equipment
- (2) Disconnect power to all EVSE and WPTE within sight of emergency shutoff
- (3) Be marked "EVSE EMERGENCY DISCONNECT" in accordance with 110.22(A)
- (4) Be a manual reset type
- (5) Disconnect all ungrounded conductors of the circuits simultaneously from the source of supply
- (6) Be listed and marked for EVSE and WPTE

The disconnecting means required in accordance with 625.43(A) shall be permitted to serve as the emergency disconnect if it complies with all the requirements of 625.43(B).

Statement of Problem and Substantiation for Public Comment

Low-cost pull-out type disconnects, commonly used for residential air conditioners, have been failing in EVSE applications. This adds a requirement consistent with the draft revision of 625.44, requiring receptacles to be listed and marked for the application.

Related Item

- FR-8346-NFPA 70-2024

Submitter Information Verification

Submitter Full Name: Charles Sullivan

Organization: Thayer School of Engineering at Dartmouth

Street Address:

City:

State:

Zip:

Submittal Date: Tue Aug 27 11:17:06 EDT 2024

Committee: NEC-P12



Public Comment No. 1946-NFPA 70-2024 [Section No. 625.43(B)]

(B) Emergency Shutoff.

For permanently connected EVSE and WPTE, one or more clearly identified emergency disconnect devices or electrical disconnects shall be provided and shall meet all of the following:

- (1) Be installed in a readily accessible location in sight from the equipment
- (2) Disconnect power to all EVSE and WPTE within sight of emergency shutoff
- (3) Be marked "EVSE EMERGENCY DISCONNECT" in accordance with 110.22(A)
- (4) Be a manual reset type
- (5) Disconnect all ungrounded conductors of the circuits simultaneously from the source of supply

The disconnecting means required in accordance with 625.43(A) shall be permitted to serve as the emergency disconnect if it complies with all the requirements of 625.43(B).

Exception to (1): In one and two family dwellings, for EVSE rated not more than 150 volts to ground, a readily accessible service, feeder, or EVSE branch circuit disconnecting means that disconnects the supply to the EVSE shall be permitted to be marked as the EVSE emergency disconnect and shall not be required to be within sight of the EVSE.

Statement of Problem and Substantiation for Public Comment

The first revision of this section introduces a discriminatory and onerous requirement for Level I or II EVSE in residential contexts, even though three of the four PIs that inspired this revision cite only concerns about public and commercial contexts. (And the fourth PI is vague about which contexts concern the submitter.) Note that the idea of an 'emergency disconnect' came from a PI that cited NFPA 30A, which applies to Motor Fuel Dispensing Facilities and Repair Garages, not residences. The requirement is discriminatory because we do not require emergency disconnects for common residential equipment of similar volt and ampere ratings, such as electric ranges, water heaters, or electric dryers, even though such appliances do not contain the safety features that are the whole purpose of Level I and II EVSE. The proposed exception alleviates the discriminatory aspect of the new requirement, while preserving the desire to provide Emergency Disconnects at public and commercial charging facilities.

Note that without such an exception, contractors will resort to using cord and plug connected EVSE instead of hardwired EVSE in residences, to avoid expensive and ugly disconnects within sight. Receptacles introduce an additional point of failure and are arguably less safe than hardwired EVSE. Personally, I have seen far more reports of problems with receptacles for EVSE than I have heard of residential emergencies where an additional EVSE Emergency Disconnect would have saved life or limb. Melted receptacles can start fires. This new emergency disconnect requirement could do more harm than good without the exception.

There is precedent in the code for permitting a service or feeder disconnecting means to serve as an emergency disconnect for a subset of the equipment it supplies, namely in 690.12, PV rapid shutdown. To the extent that a service or emergency disconnecting means is more likely to be exterior to the dwelling (i.e. compliant with 2023 NEC 230.85 or the first draft of the 2026 NEC), it makes sense to allow that disconnect to serve as the disconnect for first responders. In fact, if the emergency is actually specific to the EV or EVSE, first responders will likely prefer to use the service disconnect than go near the EV and EVSE, given the option.

It makes sense to have the exception apply to one and two family dwellings, since in buildings with more or larger occupancies, distances between EVSE and service or distribution equipment are likely to be greater, and shutting off power to the entire facility would be more disruptive and possibly cause other hazards.

The inclusion of 'not more than 150 volts to ground' in the exception is intended to clarify that the exception would not apply to higher than Level II EVSE, should someone perchance install such a thing in a residence.

Finally I would note that none of the PIs related to this first revision cite any known incidents where an EVSE Emergency Disconnect would have saved life, limb, or property in a one or two family dwelling, or for that matter any actual known incidents with EVSE whatsoever. In fact, I could argue the entire first revision is based on pure speculation and paranoia about EVSE in general. EVSE have been designed in an era of comprehensive product standards and have proven to be quite safe. I could argue that this entire first revision is a solution to a so far non-existent problem, and should be retracted. However, since there seems to be a strong desire for emergency disconnects for EVSE in public contexts, and for higher voltage EVSE the stakes are obviously higher, I propose the exception as a compromise.

Related Item

- First Revision No. 8317-NFPA 70-2024 [Section No. 625.43]

Submitter Information Verification

Submitter Full Name: Joel Frangquist

Organization: A1 Sun Inc.

Street Address:

City:

State:

Zip:

Submittal Date: Wed Aug 28 12:18:49 EDT 2024

Committee: NEC-P12



Public Comment No. 554-NFPA 70-2024 [Section No. 625.43(B)]

(B) Emergency Shutoff.

For ~~other than one- and two-family dwelling units,~~ permanently connected EVSE and WPTE, one or more clearly identified emergency disconnect devices or electrical disconnects shall be provided and shall meet all of the following:

- (1) ~~Be installed~~ Installed in a readily accessible location ~~in sight from the equipment~~
- (2) ~~Disconnect power to all EVSE and WPTE within sight of emergency shutoff~~
~~Be marked "EVSE EMERGENCY DISCONNECT" in accordance with~~
- (3) , no less than 6m (20ft) or more than 30m(100ft), and visible from the EVSE or WPTE
- (4) Marked "EVSE EMERGENCY DISCONNECT" and "WARNING ELECTRIC VEHICLE(S) WILL REMAIN ENERGIZED" in accordance to 110.22(A)

~~Be a manual reset type~~

- (5)
 - (1) Markings shall comply with both of the following:
 - (6) The markings shall be located on the outside front of the disconnect enclosure with a red background and white text.
 - (7) The letters shall be at least 13mm (1/2in.) high.
 - (8) Incorporate a manual reset
- (9) Disconnect all ungrounded conductors of the circuits simultaneously from the source of supply

The disconnecting means required in accordance with 625.43(A) shall be permitted to serve as the emergency disconnect if it complies with all the requirements of 625.43(B).

Additional Proposed Changes

<u>File Name</u>	<u>Description</u>	<u>Approved</u>
2024-07-30_625.43B.png	Proposed text and formatting...NEC editing tool makes viewing of the proposal, unviewable...	

Statement of Problem and Substantiation for Public Comment

One- and two-family dwelling is outside of the scope for this requirement.

A 6 m (20 ft) minimum distance is required for the Emergency Disconnect to provide a safe distance in case of a vehicle fire. A 30m (100ft) maximum distance was used to ensure that the Emergency Disconnects is visible to the equipment. The marking requirement was expanded to make it clear that the Emergency Disconnect only de-energizes the EVSE or WPTE and that the EV vehicle is still energized.

Related Item

- FR-8317

Submitter Information Verification

Submitter Full Name: Indra Wiryadinata
Organization: Tesla
Street Address:
City:
State:
Zip:
Submittal Date: Wed Jul 31 12:34:35 EDT 2024
Committee: NEC-P12

(B) Emergency Shutoff.

For other than one- and two-family dwelling units, permanently connected EVSE and WPTE, one or more clearly identified emergency disconnect devices or electrical disconnects shall be provided and shall meet all of the following:

- (1) Installed in readily accessible location, no less than 6m (20ft) or more than 30m(100ft), and visible to the EVSE and WPTE
- (2) Marked "EVSE EMERGENCY DISCONNECT" and "WARNING ELECTRIC VEHICLE(S) WILL REMAIN ENERGIZED" in accordance to 110.22(A)
 - (1) Markings shall comply with both of the following:
 - (1) The markings shall be located on the outside front of the disconnect enclosure with a red background and white text.
 - (1) The letters shall be at least 13mm (1/2in.) high.
- (3) Incorporate a manual reset
- (4) Disconnect all ungrounded conductors of the circuits simultaneously from the source of supply

The disconnecting means required in accordance with 625.43(A) shall be permitted to serve as the emergency disconnect if it complies with all the requirements of 625.43(B).



Public Comment No. 1779-NFPA 70-2024 [Section No. 625.43 [Excluding any Sub-Sections]]

EVSE and WPTE, shall be provided with one or more disconnecting means in accordance with 625.43(A) and 625.43(B) with the exception of single-family dwellings.

Statement of Problem and Substantiation for Public Comment

The substantiation provided for this requirement was based purely on public charging scenarios at apartment buildings, workplaces, and highway charging stops. They are not necessary in a single-family residential context. Emergency responders can easily find and disconnect power to the whole building, and turning off the circuit breaker can be used for servicing the equipment. The problems with this requirement for residential installations are:

1. Typical low-cost pull-out disconnects that are commonly used for residential air-conditioning installations are failing frequently in EV charging installations. This is similar to the problem with residential-grade 14-50Rs failing in EV charging duty. Requiring disconnects before their are options that are clearly EV rated will add a new safety problem.

2. EVSE for outdoor charging is often installed on the front of the house, making aesthetics important to many homeowners. EVSEs are offered in many attractive styles for this reason. Disconnects required for air conditioning or the service entrance are typically on the side or back of the house, where aesthetic compromises are more acceptable. While aesthetics should never override safety considerations, there is no substantiated safety problem being solved in the single-family dwelling application.

A first responder would want to go to the disconnect at the service entrance rather than the EVSE disconnect anyway, to remove all hazards and to stay away from a vehicle that might be hazardous.

Related Item

• FR-8317-NFPA 70-2024 • Public Input No. 2469-NFPA 70-2023

Submitter Information Verification

Submitter Full Name: Charles Sullivan
Organization: Thayer School of Engineering at Dartmouth
Street Address:
City:
State:
Zip:
Submittal Date: Tue Aug 27 10:55:02 EDT 2024
Committee: NEC-P12



Public Comment No. 1069-NFPA 70-2024 [Section No. 625.44]

625.44 Equipment Connection.

EVSE and WPTE that is connected to the premises wiring shall be connected in accordance with one of the methods in 625.44(A) through 625.44(C). Cord- and plug-connected equipment shall be provided with an attachment plug rated not less than 125 percent of the maximum rating of the equipment.

(A) Portable Equipment.

Portable equipment shall be connected to the premises wiring system by one or more of the following methods:

- (1) A nonlocking, 2-pole, 3-wire grounding-type receptacle outlet rated at 125 volts or 250 volts, single phase in accordance with one of the following:
 - (2) .15 or 20 amperes
 - (3) 30 or 50 amperes

~~listed and marked~~

- a. listed for EVSE and WPTE use

- (4) A nonlocking, 3-pole, 4-wire grounding-type receptacle outlet rated at 125/250 volts, single phase in accordance with one of the following:
 - (5) .15 or 20 amperes
 - (6) 30, 50, or 60 amperes

~~listed and marked~~

- a. listed for EVSE and WPTE use

- (7) A nonlocking, 2-pole, 3-wire grounding-type receptacle outlet rated at 277 volts, single phase in accordance with one of the following:
 - (8) .15 or 20 amperes
 - (9) 30 or 50 amperes

~~listed and marked~~

- a. listed for EVSE and WPTE use

- (10) A nonlocking, 2-pole, 3-wire grounding-type receptacle outlet rated at 60 volts dc maximum, 15 or 20 amperes

(B) Fastened-in-Place Equipment.

Equipment that is fastened-in-place shall be connected to the premises wiring system by one of the following methods:

- (1) A nonlocking, 2-pole, 3-wire grounding-type receptacle outlet rated 125 volts or 250 volts, single phase in accordance with one of the following:
 - (2) . 15 or 20 amperes
 - (3) 30 or 50 amperes

~~listed and marked~~

- a. listed for EVSE and WPTE use

- (4) A nonlocking, 3-pole, 4-wire grounding-type receptacle outlet rated 250 volts, three phase in accordance with one of the following:
 - (5) . 15 or 20 amperes
 - (6) 30, 50, or 60 amperes

~~listed and marked~~

- a. listed for EVSE and WPTE use

- (7) A nonlocking, 3-pole, 4-wire grounding-type receptacle outlet rated 125/250 volts, single phase in accordance with one of the following:
 - (8) . 15 or 20 amperes
 - (9) 30, 50, or 60 amperes

~~listed and marked~~

- a. listed for EVSE and WPTE use

- (10) A nonlocking, 2-pole, 3-wire grounding-type receptacle outlet rated 277 volts, single phase in accordance with one of the following:
 - (11) . 15 or 20 amperes
 - (12) 30, 50, or 60 amperes

~~listed and marked~~

- a. listed for EVSE and WPTE use

- (13) A nonlocking, 3-pole, 4-wire grounding-type receptacle outlet rated at 120/208 volts, three phase in accordance with one of the following:
 - (14) . 15 or 20 amperes
 - (15) 30, 50, or 60 amperes

~~listed and marked~~

- a. listed for EVSE and WPTE use

- (16) A nonlocking, 2-pole, 3-wire grounding-type receptacle outlet rated 60 volts dc maximum, 15 or 20 amperes

(C) Fixed-in-Place Equipment.

All other EVSE and WPTE shall be permanently wired and fixed-in-place to the supporting surface.

Statement of Problem and Substantiation for Public Comment

Terra Note: This public comment only removes the words "and marked" from (A)(1)(b), (2)(b), (3)(b), (B)(1)(b), (2)(b), (3)(b), (4)(b), and (5)(b). It does not add a new subscript "a.", that was done by Terra and is not the intent of this comment.

The first draft verbiage requires the receptacle to be Listed and marked for EVSE and WPTE use so that a Listed receptacle only has to be marked for EVSE and WPTE use. The intent of the requirement is that the receptacle be Listed for EVSE and WPTE use to withstand the extreme conditions EV charging subject a receptacle to in the field. The identification of the receptacle for the EV use will be part of the certification so that a consumer, installer and code authority can identify a receptacle Listed for EV use.

Related Item

- First Revision No. 8346

Submitter Information Verification

Submitter Full Name: Thomas Lichtenstein

Organization: UL Solutions

Street Address:

City:

State:

Zip:

Submittal Date: Tue Aug 13 14:41:11 EDT 2024

Committee: NEC-P12



625.44 Equipment Connection.

EVSE and WPTE that is connected to the premises wiring shall be connected in accordance with one of the methods in 625.44(A) through 625.44(C). Cord- and plug-connected equipment shall be provided with an attachment plug rated not less than 125 percent of the maximum rating of the equipment.

(A) Portable Equipment.

Portable equipment shall be connected to the premises wiring system by one or more of the following methods:

- (1) A nonlocking, 2-pole, 3-wire grounding-type receptacle outlet rated at 125 volts or 250 volts, single phase in accordance with one of the following:
 - a. 15 or 20 amperes
 - b. 30 or 50 amperes listed and marked for EVSE and WPTE use
- (2) A nonlocking, 3-pole, 4-wire grounding-type receptacle outlet rated at 125/250 volts, single phase in accordance with one of the following:
 - a. 15 or 20 amperes
 - b. 30, 50, or 60 amperes listed and marked for EVSE and WPTE use
- (3) A nonlocking, 2-pole, 3-wire grounding-type receptacle outlet rated at 277 volts, single phase in accordance with one of the following:
 - a. 15 or 20 amperes
 - b. 30 or 50 amperes listed and marked for EVSE and WPTE use
- (4) A nonlocking, 2-pole, 3-wire grounding-type receptacle outlet rated at 60 volts dc maximum, 15 or 20 amperes

(B) Fastened-in-Place Equipment.

Equipment that is fastened-in-place shall be connected to the premises wiring system by one of the following methods:

- (1) A nonlocking, 2-pole, 3-wire grounding-type receptacle outlet rated 125 volts or 250 volts, single phase in accordance with one of the following:
 - a. 15 or 20 amperes
 - b. 30 or 50 amperes listed and marked for EVSE and WPTE use
- (2) A nonlocking, 3-pole, 4-wire grounding-type receptacle outlet rated 250 volts, three phase in accordance with one of the following:
 - a. 15 or 20 amperes
 - b. 30, 50, or 60 amperes listed and marked for EVSE and WPTE use
- (3) A nonlocking, 3-pole, 4-wire grounding-type receptacle outlet rated 125/250 volts, single phase in accordance with one of the following:
 - a. 15 or 20 amperes
 - b. 30, 50, or 60 amperes listed and marked for EVSE and WPTE use
- (4) A nonlocking, 2-pole, 3-wire grounding-type receptacle outlet rated 277 volts, single phase in accordance with one of the following:
 - a. 15 or 20 amperes
 - b. 30, 50, or 60 amperes listed and marked for EVSE and WPTE use
- (5) A nonlocking, 3-pole, 4-wire grounding-type receptacle outlet rated at 120/208 volts, three phase in accordance with one of the following:
 - a. 15 or 20 amperes
 - b. 30, 50, or 60 amperes listed and marked for EVSE and WPTE use
- (6) A nonlocking, 2-pole, 3-wire grounding-type receptacle outlet rated 60 volts dc maximum, 15 or 20 amperes

(C) Fixed-in-Place Equipment.

All other EVSE and WPTE shall be permanently wired and fixed-in-place to the supporting surface.

Additional Proposed Changes

<u>File Name</u>	<u>Description</u>	<u>Approved</u>
CN_344.pdf		

Statement of Problem and Substantiation for Public Comment

NOTE: The following CC Note No. 344 appeared in the First Draft Report on First Revision No. 8335.

CMP 12 should consider whether this requirement is complete as written. For cord- and plug-connected equipment, the requirement only applies as written to the rating of the plug, and not the cord. The statement, "cord-and-plug connected equipment shall be provided with an attachment plug rated not less than 125 percent of the maximum rating of the equipment.", provides a requirement for the attachment plug, but is silent on the rating of the cord.

Related Item

- First Revision No. 8335

Submitter Information Verification

Submitter Full Name: CC Notes

Organization: NEC Correlating Committee

Street Address:

City:

State:

Zip:

Submittal Date: Fri Aug 02 08:59:29 EDT 2024

Committee: NEC-P12



Correlating Committee Note No. 344-NFPA 70-2024 [Section No. 625.44]

Submitter Information Verification

Committee: NEC-AAC

Submittal Date: Fri May 10 08:04:19 EDT 2024

Committee Statement

Committee Statement: CMP 12 should consider whether this requirement is complete as written. For cord- and plug-connected equipment, the requirement only applies as written to the rating of the plug, and not the cord. The statement, “cord-and-plug connected equipment shall be provided with an attachment plug rated not less than 125 percent of the maximum rating of the equipment.”, provides a requirement for the attachment plug, but is silent on the rating of the cord.

First Revision No. 8335-NFPA 70-2024 [Section No. 625.44 [Excluding any Sub-Sections]]

Ballot Results

✓ **This item has passed ballot**

12 Eligible Voters

1 Not Returned

11 Affirmative All

0 Affirmative with Comments

0 Negative with Comments

0 Abstention

Not Returned

McDaniel, Roger D.

Affirmative All

Ayer, Lawrence S.

Bowmer, Trevor N.

Hickman, Palmer L.

Holub, Richard A.

Jackson, Peter D.

Kendall, David H.

Manche, Alan

Osborne, Robert D.

Porter, Christine T.

Schultheis, Timothy James

Williams, David A.



Public Comment No. 1680-NFPA 70-2024 [Section No. 625.44(A)]

(A) Portable Equipment.

Portable equipment shall be connected to the premises wiring system by one or more of the following methods:

- (1) A ~~nonlocking, 2~~ 2-pole, 3-wire grounding-type receptacle outlet rated at 125 volts or 250 volts, single phase in accordance with one of the following:
 - (2) .15 or 20 amperes
 - (3) 30 or 50

~~amperes listed and marked for EVSE and WPTE use~~

- a. amperes

- (4) A ~~nonlocking, 3~~ 3-pole, 4-wire grounding-type receptacle outlet rated at 125/250 volts, single phase in accordance with one of the following:
 - (5) .15 or 20 amperes
 - (6) 30, 50, or 60 amperes

~~listed and marked for EVSE and WPTE use~~

- a.

- (7) A ~~nonlocking, 2~~ 2-pole, 3-wire grounding-type receptacle outlet rated at 277 volts, single phase in accordance with one of the following:
 - (8) .15 or 20 amperes
 - (9) 30 or 50 amperes

~~listed and marked for EVSE and WPTE use~~

- a.

- (10) ~~A~~
~~nonlocking,~~
(11) ~~3-pole, 4-wire grounding type receptacle outlet rated at 480 volts, three phase in accordance with one of the following:~~
 - (12) 30, 60, or 100 amperes

- (13) ~~A~~ 2-pole, 3-wire grounding

~~.~~

- (14) ~~. type receptacle outlet rated at~~
~~60 volts~~

- (15) 60 volts dc maximum, .15 or 20 amperes .

(B) Listed Connections

- (1) All plugs, connectors, and receptacles shall be listed for the appropriate voltage and current of the portable charging system.
- (2) Connections shall be of the locking or nonlocking type.

Statement of Problem and Substantiation for Public Comment

The adopted maximum voltage and plug/connector specifications for portable equipment are too restrictive. To facilitate the development of charging infrastructure, portable charging equipment must support higher voltage and current ratings.

Portable charging equipment can safely handle up to 480 volts line-to-line and currents up to 200 amps by utilizing listed, readily available cord-connected apparatus. These power levels are already standard in various market segments, including welding, automotive, mining, and general industrial equipment.

The requirement for a specific "EVSE" marking on cord and plug devices is restricting the market, favoring select manufacturers and creating a strategic monopoly in the EVSE market segment. In reality, the electrical characteristics of EVSE equipment are no different from other cord and plug utilization equipment when built and tested according to applicable standards. Due to limited support for EV-specific equipment, the growth of the EVSE market is being constrained by an already stressed national supply chain system.

Ensuring the effective and safe operation of Level 3 charging equipment for electric vehicles (EVs) is paramount to fostering widespread adoption of electric mobility. Level 3 chargers, also known as DC fast chargers, significantly reduce charging time, providing an 80% charge in approximately 30 minutes. This efficiency is crucial for the convenience of EV owners and operators, as well as the overall practicality of electric vehicles.

However, the rapid evolution of EV technology presents a challenge, as there are currently very limited standards that adequately support new advancements. This underscores the need for ongoing collaboration between manufacturers and regulatory bodies to develop and implement standards that keep pace with technological innovations.

By prioritizing these safety, operational, and design guidelines, we can ensure that Level 3 charging infrastructure remains reliable, efficient, safe, and user-friendly, ultimately supporting the growth of the EV market and contributing to a sustainable future.

Related Item

- Public Input No. 2552-NFPA 70-2023 [Sections 625.44(A), 625.44(B)]

Submitter Information Verification

Submitter Full Name: Bryan Seymour

Organization: Beta Technologies
Street Address:
City:
State:
Zip:
Submittal Date: Mon Aug 26 10:25:12 EDT 2024
Committee: NEC-P12



Public Comment No. 1710-NFPA 70-2024 [Section No. 625.44(A)]

(A) Portable Equipment.

Portable equipment shall be connected to the premises wiring system by one or more of the following methods:

- (1) A nonlocking, 2-pole, 3-wire grounding-type receptacle outlet rated at 125 volts or 250 volts, single phase in accordance with one of the following:
 - (2) . 15 or 20 amperes
 - (3) . 30 or 50 amperes listed and marked for EVSE and WPTE use
- (4) A nonlocking, 3-pole, 4-wire grounding-type receptacle outlet rated at 125/250 volts, single phase in accordance with one of the following:
 - (5) . 15 or 20 amperes
 - (6) . 30, 50, or 60 amperes listed and marked for EVSE and WPTE use
- (7) A nonlocking, 2-pole, 3-wire grounding-type receptacle outlet rated at 277 volts, single phase in accordance with one of the following:
 - (8) . 15 or 20 amperes
 - (9) . 30 or 50 amperes listed and marked for EVSE and WPTE use
- (10) A nonlocking, 2-pole, 3-wire grounding-type receptacle outlet rated at 60 volts dc maximum, 15 or 20 amperes
- (11) A locking, pin-and-sleeve, 3-pole, 4-wire grounding type receptacle outlet rated at 277/480 volts, three phase 30, 60, or 100 amperes

Statement of Problem and Substantiation for Public Comment

Additional increase in power based on FR-8346. Added support for locking type pin-and-sleeve connectors rated 277/480V and up to 100A, commonly used in higher power commercial and industrial applications and listed for UL 1682 or equivalent.

Allowance for portable and fastened-in place 277/480V supplied DC charging equipment is important to support solutions for the new and growing large commercial EV fleet that include school buses, transit buses, motor coaches, semi-trucks, garbage trucks, etc. These vehicles tend to have large capacity batteries and often do not have an onboard charger, hence accept DC only. These types of facilities have 277/480V receptacles installed for other applications can be utilized to supply portable DC charging equipment to support repair and maintenance work performed in the facility as needed.

With the allowance of these types of connections, fewer DC fast chargers can be shared among multiple bays in a repair garage in a manner consistent with established safe practices. Without this allowance maintenance facilities for these vehicles would require permanent installations in every bay or have reduced flexibility which may encourage less safe workarounds, such as towing for charging.

Locking type pin-and-sleeve plugs and receptacles are well suited for applications of this type because they tend to be ruggedized, provide sealing between the connections and the environment, preventing accidental disconnection. Based on SAE J1772, section 4.6.2, EVs are additionally responsible to disallow drivers to cause movement of the vehicle when mated with a charging cable vehicle connector.

Related Item

- FR-8346

Submitter Information Verification

Submitter Full Name: Sesha Yeruva

Organization: Siemens

Street Address:

City:

State:

Zip:

Submittal Date: Mon Aug 26 14:30:37 EDT 2024

Committee: NEC-P12



Public Comment No. 1203-NFPA 70-2024 [Section No. 625.44 [Excluding any Sub-Sections]]

EVSE and WPTE that is connected to the premises wiring shall be connected in accordance with one of the methods in 625.44(A) through 625.44(C). Cord- and plug-connected equipment shall be provided with an attachment plug rated not less than 125 percent of the maximum rating of the equipment. EVSE Branch Circuit ratings shall be limited to 15, 20, 30, 50, or 60 Ampere rating. A 50 Ampere rated receptacle shall not be installed on a 40-ampere Branch Circuit as allowed in Section 210.24(1).

Statement of Problem and Substantiation for Public Comment

There is problem in the field that changing EVSE equipment with higher amperage rating at the 40/50 Amp range, allows a 40 Amp rated circuit to operate at 100 % if a 50 Ampere rated receptacle is used and allowed under 210.24. The higher ampere rated receptacle is operated on lower ampere Branch Circuit. The modification of the original Public Input and subsequent First Revision, further reinforces the Cord and Plug rating as it relates to the Branch Circuit rating.

Related Item

- FR8335 • PI 4206

Submitter Information Verification

Submitter Full Name: Megan Hayes

Organization: NEMA

Street Address:

City:

State:

Zip:

Submittal Date: Sat Aug 17 00:47:18 EDT 2024

Committee: NEC-P12



Public Comment No. 129-NFPA 70-2024 [Section No. 625.54]

625.54 Ground-Fault Circuit-Interrupter Protection for Personnel.

All ~~receptacles and outlets installed for the connection of~~ outlets supplying electric vehicle charging equipment, shall have ground-fault circuit-interrupter protection for personnel.

Statement of Problem and Substantiation for Public Comment

Saying "All receptacles and outlets" is a redundant statement and would just lead to confusion. "Outlet" is a defined term and would be sufficient to make clear that all EVSE equipment needs to be GFCI protected. The other wording was changed for readability and usability of the code.

Related Item

- FR-8378

Submitter Information Verification

Submitter Full Name: Jesse Duvuvei

Organization: North Strabane Township

Street Address:

City:

State:

Zip:

Submittal Date: Sat Jul 20 15:02:09 EDT 2024

Committee: NEC-P12



Public Comment No. 130-NFPA 70-2024 [Section No. 625.54]

625.54 Ground-Fault Circuit-Interrupter Protection for Personnel.

All ~~receptacles and outlets installed~~ receptacles installed for the ~~connection of~~ connection of electric vehicle ~~charging shall~~ charging shall have ground-fault circuit-interrupter protection for personnel.

Statement of Problem and Substantiation for Public Comment

The submitter of PI-1440 never submitted substantiation showing that other than receptacle connection electric vehicle charging equipment presented a hazard. The submittal violated 4.3.4.1(d) of the NFPA Regulations Governing the Development of Standards and should not proceed past this meeting.

Related Item

- PI-1440

Submitter Information Verification

Submitter Full Name: Jesse Duvuvei

Organization: North Strabane Township

Street Address:

City:

State:

Zip:

Submittal Date: Sat Jul 20 15:06:15 EDT 2024

Committee: NEC-P12



Public Comment No. 1341-NFPA 70-2024 [Section No. 625.54]

625.54 Ground-Fault Circuit-Interrupter Protection for Personnel.

All receptacles ~~and outlets~~ installed for the connection of electric vehicle charging shall have ground-fault circuit-interrupter protection for personnel.

Statement of Problem and Substantiation for Public Comment

This comment is being submitted on behalf of the Minnesota Department of Labor and Industry. Currently, the Department's inspection staff includes 14-office/field staff, 50-state field inspectors, 4-virtual inspectors and 22 plus contract electrical inspectors that complete over 170,000 electrical inspections annually.

The substantiation is not consistent with language. Please review FR 8378 and provide substantiation to further explain the expansion of the GFCI protection to "outlets". None of the PIs requested the expansion of the section. In addition, in some cases, the GFCI protection will create unwanted tripping due to the EVSE equipment already providing protection systems within their equipment. Please be sure that there won't be compatibility issues before implementing this additional protection.

Related Item

- First Revision No. 8378-NFPA 70-2024 Section No. 625.54

Submitter Information Verification

Submitter Full Name: Dean Hunter

Organization: Minnesota Department of Labor

Street Address:

City:

State:

Zip:

Submittal Date: Tue Aug 20 17:28:03 EDT 2024

Committee: NEC-P12



Public Comment No. 1477-NFPA 70-2024 [Section No. 625.54]

625.54 Ground-Fault Circuit-Interrupter Protection for Personnel.

All receptacles and outlets installed for the connection of electric vehicle charging shall have ground-fault circuit-interrupter protection for personnel.

Exception: Outlets that are installed to supply DC charging do not require GFCI protection

Statement of Problem and Substantiation for Public Comment

In DC charging equipment, the DC output is isolated from the input, and therefore a GFCI on the supply circuit would be incapable of detecting ground faults on the output side. As applied to DC charging equipment, the GFCI requirements in the first draft would be ineffective in protecting people from ground faults. Additionally, listed DC equipment is required to have ground monitoring circuits that deny power when ground connections are lost or in cases where there is low resistance to ground.

Related Item

- First Revision No. 8378-NFPA 70-2024 [Section No. 625.54]

Submitter Information Verification

Submitter Full Name: John Cowans

Organization: Siemens

Street Address:

City:

State:

Zip:

Submittal Date: Fri Aug 23 13:37:54 EDT 2024

Committee: NEC-P12



Public Comment No. 1730-NFPA 70-2024 [Section No. 625.54]

625.54 Ground-Fault Circuit-Interrupter Protection for Personnel.

All receptacles ~~and outlets~~ installed for the plug connection of electric vehicle charging shall have ground-fault circuit-interrupter protection for personnel or mechanical interlocks to prevent exposure to live conductors .

For hardwired electric vehicle charging circuits, equipment that provides listed personnel protection shall not require an upstream ground-fault circuit-interrupter. If a ground-fault circuit-interrupter is supplied for a hardwired outlet circuit, the shutoff shall be accessible to the vehicle user, including apartment or multifamily users.

For hardwired electric vehicle charging circuits supporting bidirectional charging, no separate ground-fault circuit-interrupter shall be installed.

Additional Proposed Changes

<u>File Name</u>	<u>Description</u>	<u>Approved</u>
Edison_Base_Fuses_30A_Screw_- _Like_a_GFCI_Breaker.pdf	Obsolete Edison base fuse, which like a modern GFCI can be swapped out by untrained persons	

Statement of Problem and Substantiation for Public Comment

The built in listed personnel protection of EVSE is more reliable than depending on an upstream GFCI.

The listed personnel protection has the ability to retry in case of transients caused by snow or weather conditions or based on stray currents from the vehicle. The listed protection can't be swapped out for a non-GFCI breaker, as with a conventional upstream dedicated GFCI.

Related Public Comments for This Document

<u>Related Comment</u>	<u>Relationship</u>	<u>Related Item</u>
Public Comment No. 1811-NFPA 70-2024 [New Section after 210.8(E)]		
• Public Input No. 1802-NFPA 70-2023 [Section No. 625.54]	• Nuisance Tripping of Ground-Fault Circuit Interrupters (GFCIs) for Appliances February 5, 2024, AHAM	

Submitter Information Verification

Submitter Full Name: Bryce Nesbitt
Organization: Obviously Inspects / Expert Witness
Street Address:
City:
State:
Zip:
Submittal Date: Mon Aug 26 19:24:47 EDT 2024
Committee: NEC-P12



**LOOK FOR THE BUSS LABEL
BEFORE BUYING FUSES**

All labeled fuses are not equally good but unlabeled fuses are dangerous. They may start fires or cause injury. Be safe. The BUSS Trade Mark means the fuse will operate as intended with safety and accuracy under any service condition.

McGraw-Hill MFG. DIVISION, McGraw-Hill
BUSS Fuses are made in the U.S.A.



Public Comment No. 1731-NFPA 70-2024 [Section No. 625.54]

625.54 Ground-Fault Circuit-Interrupter Protection for Personnel.

All ~~receptacles and outlets installed~~ receptacles installed for the connection of electric vehicle charging shall have ground-fault circuit-interrupter protection for personnel.

Statement of Problem and Substantiation for Public Comment

i have been an electrical installer and developer of new electrical products with safety in mind. The proposed change to add outlets or hard wired EV chargers to add external GFCI protection isn't based on a safety issue. There are no examples of hard wired EV chargers being an electrocution or injury caused issue. If so is there proof that there has been a death or injury due to the lack of external GFCI protection?

Dave Graves. simpleSwitch designer/owner. simpleswitch.io

Related Item

- None

Submitter Information Verification

Submitter Full Name: David Graves

Organization: simpleswitch

Street Address:

City:

State:

Zip:

Submittal Date: Mon Aug 26 19:30:19 EDT 2024

Committee: NEC-P12



Public Comment No. 1768-NFPA 70-2024 [Section No. 625.54]

625.54 Ground-Fault Circuit-Interrupter Protection for Personnel.

All ~~receptacles and outlets installed~~ receptacles installed for the connection of electric vehicle charging shall have ground-fault circuit-interrupter protection for personnel.

Statement of Problem and Substantiation for Public Comment

Including all outlets would require adding a GFCI breaker for hard wired level 2 EVSEs. This would create two problems.

First, experience in the field shows that false trips are common when such equipment is on GFCI breakers. Most hardwired L2 hard wired EVSEs use the option in UL 2231 to combine CCID20 with GMI (ground monitor interrupter). The GMI circuit applies a small ground current to check for intact bonding. That combined with other leakage currents, including in the vehicle, leads to false tripping being common enough that many manufacturers warn against using a GFCI breaker, suggesting hard wiring as a way to avoid the need for the GFCI breaker that is now required for a receptacle. This change would remove that safe and reliable option.

The second problem is simply that this would add cost with no clear benefit: The UL standard has proven to provide excellent safety for the charging cable and vehicle interface, providing automatic shutoff not only for ground faults, but also when the cable is disconnected from the vehicle or when the vehicle is not requesting power.

The requirement would be particularly challenging for circuit capacity > 60 A. 210.8 D does not require single-phase circuits to have GFCI protection above 60 A, and achieving adequate sensitivity for a 5 mA trip point at 80 or 100 A is challenging and expensive.

Non-locking plug and receptacle interfaces have a real hazard of exposed energized plug blades during connection and disconnection, and the requirement to have a GFCI upstream of a receptacle like that make sense. There's no such hazard with a hard wired EVSE: the interface to the car has no exposed conductors, in addition to being de-energized during connection and disconnection and having CCID protection. So this is not needed and will cause serious practical problems.

Related Item

• Public Input No. 1440-NFPA 70-2023 [Section No. 625.54] • Public Input No. 1802-NFPA 70-2023 [Section No. 625.54]

Submitter Information Verification

Submitter Full Name: Charles Sullivan

Organization: Thayer School of Engineering at Dartmouth

Street Address:

City:

State:

Zip:

Submittal Date: Tue Aug 27 09:29:34 EDT 2024

Committee: NEC-P12



Public Comment No. 1808-NFPA 70-2024 [Section No. 625.54]

625.54 Ground-Fault Circuit-Interrupter Protection for Personnel.

All receptacles and outlets installed for the connection of electric vehicle charging shall have ground-fault circuit-interrupter protection for personnel.

Additional Proposed Changes

<u>File Name</u>	<u>Description</u>	<u>Approved</u>
Doc1.docx		

Statement of Problem and Substantiation for Public Comment

Today, most GFCIs can function for bidirectional use, despite their labeling. However, UL testing has shown some to get damaged and cease to protect when subject to bidirectional power. Many emerging products such as balcony PV and V2G EV chargers will backfeed power into the home. People will purchase and use these regardless of UL listing or compliance; this is not something we can easily regulate. Nonetheless, with required bidirectional GFCI breakers and outlets, we will still protect the current and future occupants from shock due to damaged GFCIs.

Related Item

- FR-7788 • Global FR 9093

Submitter Information Verification

Submitter Full Name: Daniel Gerber

Organization:

Affiliation: Lawrence Berkeley National Laboratory

Street Address:

City:

State:

Zip:

Submittal Date: Tue Aug 27 13:38:57 EDT 2024

Committee: NEC-P12

All receptacles and outlets installed for the connection of electric vehicle charging shall have ground-fault circuit-interrupter protection for personnel. Protection devices shall be rated and marked for bidirectional use.



Public Comment No. 1812-NFPA 70-2024 [Section No. 625.54]

625.54 Ground-Fault Circuit-Interrupter Protection for Personnel.

All ~~receptacles and outlets installed~~ receptacles installed for the connection of electric vehicle charging shall have ground-fault circuit-interrupter protection for personnel.

Statement of Problem and Substantiation for Public Comment

The code making panel should retract this first revision and revert the text to the 2023 NEC version, for all the following reasons:

First, the PI that was approved to make this first revision lacked any coherent or compelling statement of a problem or technical substantiation. When I read the original Statement of Problem and Substantiation for Public Input, it even seems as if the submitter may have been arguing for something different and was confused about the consequence of their proposed revision. The PI does not refer to any known incidents involving hardwired EVSE, or discuss any differences or similarities between EVSE circuits with and without receptacles. Because EVSE only energize their output cables upon connection to an EV, they are arguably safer than devices and equipment that are cord-and-plug connected to receptacles. By comparison, what is plugged into receptacles cannot be easily controlled. For such a consequential - and, many would argue, onerous - requirement for hardwired EVSE, a bona fide technical substantiation should be required. Not only that, but the code making panel reviewed several PIs for this section, including more than one that sought to clarify the code in an opposite direction. One of those in particular contained a very knowledgeable and technically substantive Statement of Problem and Substantiation. Adopting onerous new requirements without clear technical substantiations undermines public trust in the NFPA. So does simultaneously ignoring technical substantiations that are clearly from more competent and knowledgeable submitters.

Second, it seems as if this new requirement was adopted with little to no consultation with the EVSE manufacturing industry on the consequences or issues that might be raised by such a requirement. Numerous hardwired Level II EVSE on the US market today contain manufacturer's instructions prohibiting or discouraging the use of GFCI protection additional the ground fault protection functions they contain. If these EVSE already have ground-fault protection (say at 30mA) why isn't that good enough? If the code making panel desires to require 5ma GFCI protection specifically, did the code making panel look into why today's hardwired EVSEs don't typically have that? Did the code making panel consider whether such a requirement is feasible for EVSE whose amps or volts exceed that which can obtain a listing as cord-and-plug-connected equipment? Why is the requirement not limited to 60-amperes or less as with certain GFCI requirements in Article 210? It seems to me that the new requirement could even be interpreted by some as requiring GFCI protection 'upstream' of high-voltage DC EVSE, which would be impossible, nonsensical, and I don't believe is what the panel intended. Certainly if any consideration was given to such issues, it is not evident in the PI or the panel statement on this first revision. New requirements should be vetted for technical feasibility before being adopted, and the NFPA needs to be transparent about this.

Third, the revision adopts a problematic and vague linguistic construction that will lead to great confusion and argument in the field, namely that an "outlet ... shall have ground-fault circuit-interrupter protection." Where exactly is the outlet on an EVSE? And does the requirement to 'have' GFCI say anything about the location of the GFCI function? Note that a typical Level II EVSE is, essentially, a glorified special-purpose receptacle for a vehicle. It is no more or less utilization equipment than, say, a GFCI receptacle with an LED indicator, or especially a GFCI receptacle with a 'smart' wifi function that tells an app on your phone when it trips. (The latter is a real product from Leviton). So, is the EVSE 'utilization equipment' or not, and thus is 'outlet' at the end of the EVSE output cord where it plugs into the car? Or is it where the factory wiring leads are connected to the field-installed premises wiring? Supposing a hardwired EVSE contained internal GFCI (5ma), no additional GFCI should be required. But the linguistic construction of the first revision leaves that unclear. Note that the similar but different construction that a 'receptacle shall have GFCI' (e.g in 210.8(A) and (B)) is not problematic because it is apparent that the GFCI function could be in either the receptacle or another device on the supply side, and either way it protects the cord-and-plug-connected device or equipment at the receptacle slots. The problem with the first revision is that many will interpret it as requiring GFCI on the supply side of hardwired EVSE (meaning, practically speaking, a GFCI circuit breaker is required), even if the EVSE itself contains 5ma GFCI functionality. That would be a much more onerous requirement than for receptacles, which only would have to provide GFCI protection at their slots. It makes no sense that hardwired EVSE circuits should need GFCI protection for the entire circuit, while receptacle circuits intended for EV charging would not. In general, the code should never require 'outlets' to have GFCI protection without explicitly allowing hardwired connected equipment to provide that protection.

Related Item

- First Revision No. 8378-NFPA 70-2024 [Section No. 625.54]

Submitter Information Verification

Submitter Full Name: Joel Frangquist

Organization: A1 Sun Inc.

Street Address:

City:

State:

Zip:

Submittal Date: Tue Aug 27 14:09:59 EDT 2024

Committee: NEC-P12



Public Comment No. 1962-NFPA 70-2024 [Section No. 625.54]

625.54 Ground-Fault Circuit-Interrupter Protection for Personnel.

All receptacles ~~and outlets~~ installed for the connection of electric vehicle charging shall have ground-fault circuit-interrupter protection for personnel.
Hardwired equipment for electric vehicle charging shall have no requirement for GFCI upstream of the EVSE.

Statement of Problem and Substantiation for Public Comment

Listed EVSEs contain personnel and equipment protection circuits. Even though included GFCI protection in listed EVSE equipment is typically implemented at 20mA additional personnel protection inherent in the charge initiation protocol and plug design all but eliminates personnel hazards. Adding upstream GFCI protection adds cost but no additional protection. Both manufacturers of EV and charging solutions (Ford and Tesla) advise against the use of GFCI breakers. The proposed language of 'outlet' is unclear. Does this mean the EV charging connector? Since GFCI breakers have no requirements to prevent nuisance tripping at frequencies other than 60Hz the in-car AC-DC converter may cause nuisance tripping. EV users rely on the car being charged in the morning. Nuisance tripping of the GFCI creates highly dissatisfied customers. I have personally observed licensed electricians removing GFCI breakers in such situations to appease the customer.

[Related Item](#)

- Public Input No. 1802-NFPA 70-2023 [Section No. 625.54]

Submitter Information Verification

Submitter Full Name: Armin Karcher

Organization: N/A

Street Address:

City:

State:

Zip:

Submittal Date: Wed Aug 28 13:04:35 EDT 2024

Committee: NEC-P12



Public Comment No. 2018-NFPA 70-2024 [Section No. 625.54]

625.54 Ground-Fault Circuit-Interrupter Protection for Personnel.

~~All receptacles and outlets installed for the connection of Listed hardwired equipment for~~ electric vehicle charging shall have no ground-fault circuit-interrupter protection ~~for personnel requirement, provided the equipment is installed per the listing .~~

Statement of Problem and Substantiation for Public Comment

Hi, I run a company by the name of Moon Five Technologies. We are implementing a novel strategy that gives renters the freedom to drive electric through working with property owners to pre-wire their properties, wiring between our EMS which balances the load between the apartment and the charger, and the charging space's charger backplate. The renter then has the chance to rent a charger from us, where we own maintenance and repair for the system. Our system is not only designed for delivery of power to the charging space, but also, given our wiring, allows for the car to be used as backup power to the apartment (bi-directional) when the grid is down, peak shaving, and V2G for grid support as need be.

This rule would not allow for a majority of these bi-directional elements to occur. GFCIs will trip with bidirectional power flow, prohibiting us to provide tenants with key features to improve quality of life. More than that, we also have significant safety features which would prohibit the need for GFCI protection to begin with. Our EVSE utilizes a Mennekes type 2 connector, which is not powered until the handshake between the vehicle and the EVSE is successfully accomplished and the charger mounting plate is not electrified until the EMS system's power monitoring cartridge (installed when the user requests the equipment) is installed. On top of this, any exposed contacts are covered and locked with an anti-theft screw, making it very difficult to access the outlet.

My company is not unique in this instance as well. All EVSE providers do not electrify their cable's outputs until the vehicle is plugged in, this includes smart outlets utilized for EV charging. At minimum, I believe that there should be a distinction between systems that have energized and exposed electrical connections vs those that do not. Anything with an exposed and energized electrical connection, I believe definitely has more merit to install a GFCI protective circuit than those that are passive in their "off" state.

One last point, if you look at the Massachusetts Electrical Code (527 CMR 12.00) Rule 11 Emergency Amendment, you can see that GFCIs have noted to have created a large quantity of nuisance trips for EV Charging, which the electrical code had to be amended to adjust to.

Adding this line into the electrical code would only serve to decrease electric vehicle adoption by increasing the cost of infrastructure, increase nuisance tripping, all while only minimally adding protection.

Related Item

- Public Input No. 1440-NFPA 70-2023 [Section No. 625.54] • Massachusetts Electrical Code (527 CMR 12.00) Rule 11 Emergency Amendment

Submitter Information Verification

Submitter Full Name: Stephan Ng
Organization: Moon Five Technologies Inc.
Street Address:
City:
State:
Zip:
Submittal Date: Wed Aug 28 15:41:02 EDT 2024
Committee: NEC-P12



Public Comment No. 2037-NFPA 70-2024 [Section No. 625.54]

625.54 Ground-Fault Circuit-Interrupter Protection for Personnel.

All receptacles and outlets rated 150 volts to ground or less, 60 amperes or less, installed for the connection of electric vehicle charging shall have ground-fault circuit-interrupter protection for personnel.

Statement of Problem and Substantiation for Public Comment

This provision clarifies alignment with ratings for GFCI protection per UL product safety standard, UL 943. It also correlates with branch circuit GFCI requirements in section 210.8.

Related Item

- FR 8378

Submitter Information Verification

Submitter Full Name: Keith Waters

Organization: Schneider Electric

Street Address:

City:

State:

Zip:

Submittal Date: Wed Aug 28 16:32:35 EDT 2024

Committee: NEC-P12



Public Comment No. 2042-NFPA 70-2024 [Section No. 625.54]

625.54 Ground-Fault Circuit-Interrupter Protection for Personnel.

~~All receptacles and outlets~~

Receptacles installed for the connection of electric vehicle charging shall have ground-fault circuit-interrupter protection for personnel or listed tamper-resistant means .

Hardwired circuits for the connection of listed electric vehicle charging may be sourced from a circuit without a ground-fault circuit-interrupter.

-

Listed smart receptacles for electric vehicle charging that are electrically off when not actively in use may be sourced from a circuit without a ground-fault circuit-interrupter.

Statement of Problem and Substantiation for Public Comment

The EV Charging for All Coalition (EVCAC) requests the code making panel continue to allow "listed" electric vehicle supply equipment (EVSE) to be hard-wired without the requirements for additional safety equipment such as ground-fault circuit-interrupters (GFCI).

And that tamper resistance or listed smart receptacles are alternatives to GFCI protection for receptacles intended for EV charging.

While the EVCAC is equally concerned for safety, we understand that existing listed EVSE incorporate internationally recognized personal protection mechanisms. As such, requiring upstream GFCIs only adds additional cost, complexity and potential failure points to the installation.

Importantly, for apartment or condominium residents, locating GFCI to reset or even examine is likely extremely difficult if not impossible. This added burden will drive down EV adoption by populations that typically have the least transportation security.

Background

The EV Charging for All Coalition, a program of Acterra: Action for a Healthy Planet, is a broad coalition of nonprofits, companies, individuals and elected officials dedicated to expanding equitable access to EV charging. Our guiding principles are to minimize cost and complexity for residents, builders, and apartment/condominium managers, and to bring affordable and accessible EV Ready charging to all residents, particularly those living in Multi-Family Homes (MFH).

Over the past four years, EVCAC has worked closely with the California Department of Housing and Community Development (HCD) and the California Building Standards Commission (CBSC) to ensure that the Title 24, Part 11 CALGreen code supports equitable, cost-effective and sensible access to EV charging particularly for for residents of newly built apartments and condominiums.

Through our work and the support of many allies, beginning January 1st, 2025, all new California apartments and condominiums will be required, at a minimum, to provide a EV-Ready, low power level 2 (208/240 V, 20 A) receptacle per housing unit that has access to parking. This requirement will enable access to EV charging for the order of 50,000 new apartment and condominium units per year.

We have demonstrated to HCD and CSBC to their satisfaction that low power level 2 charging is suitable for high dwell time locations, such as overnight or at home parking spaces for residents. Further, HCD and CSBC have agreed that for EV adoption to be successful, it is more important to have dedicated charging access per unit than having a subset of the parking spaces with higher amperage (level 2) charging.

Not only does this provide certainty for the resident, it also avoids the significant inconvenience and uncertainty of the "musical cars" approach of residents needing to wait for an available level 2 charger, moving their car twice. Finally, having access to a known charger enables grid time of day optimization, such as charging during off hours or during peak solar times. This gives apartment residents the same access to lower off peak rates as single family residents.

It is critical to reflect on the differences in EV charging for those who live in single family residences compared to those who live in apartments and condominiums (multifamily housing). The single family resident, who is likely also the property owner, has agency and control over the entire ecosystem of EV charging — including the parking space the EV charger serves, the type of charger (Level 1, low power level 2 or level 2) employed, knowing the location of the circuit breaker serving the EV charger (and how to reset it), deciding on an appropriate utility tariff (and participating in demand response programs), and uploading power from the EV to home or to grid.

A resident of multifamily housing, by contrast, has essentially no agency and control. Specific to these NEC proposed requirements, an apartment or condominium resident needing to reset a tripped GFCI will likely require a call to property management. Should this happen repeatedly, the property management is simply likely to disconnect the EVSE and likely all the onsite EVSE. In turn, this will decrease overall EV adoption rates.

Related Item

• First Revision No. 8378-NFPA 70-2024 [Section No. 625.54]

Submitter Information Verification

Submitter Full Name: Sven Thesen

Organization: EVCAC

Affiliation: Electric Vehicle Charging for All Coalition, Co-Lead

Street Address:

City:

State:

Zip:

Submittal Date: Wed Aug 28 16:39:55 EDT 2024

Committee: NEC-P12



Public Comment No. 2072-NFPA 70-2024 [Section No. 625.54]

625.54- 54 Ground-Fault Circuit-Interrupter Protection for Personnel.

All receptacles and outlets

Receptacles installed for the plug connection of electric vehicle charging shall have ground-fault circuit-interrupter protection for personnel.

Outlets for electric vehicle charging shall have no ground-fault circuit-interrupter protection requirement, provided the installed equipment has listed personal protective features and is installed per the listing.

Statement of Problem and Substantiation for Public Comment

Our company is a premier local specialist in EV charger installations, we've installed thousands over a wide variety of mostly existing buildings.

Our company does many retrofit installations, where there is minimal breaker space. Currently we install hardwire EVSE safely using a quad breaker. GFCI breakers take more space, and may force a panel upgrade, with all the risks and costs of disturbing otherwise functioning older electrical wiring.

In some cases we have observed other electricians installing a GFCI for inspection, then taking it right out. This is an indication of the stress in the field GFCI has been creating. GFCI that are removed provide a false sense of safety.

An upstream hard shutoff is undesirable, as it shuts the entire equipment down, preventing an error message from being sent. Listed hardwired EVSE have required electrical safety features.

In our experience a GFCI for a Hardwired EVSE can be installed without the need for a subpanel, however the addition of a gfci breaker would require us to change the installation in many ways. Some electrical panels would require an unnecessary and costly electrical panel upgrade due to this change.

Related Item

• Public Input No. 1802-NFPA 70-2023 [Section No. 625.54] • Massachusetts Code (527 CMR 12.00) Rule 11 Amendment

Submitter Information Verification

Submitter Full Name: Paul Nijssen

Organization: EVCHARGE4U INC

Street Address:

City:

State:

Zip:

Submittal Date: Wed Aug 28 18:02:18 EDT 2024

Committee: NEC-P12



Public Comment No. 2075-NFPA 70-2024 [Section No. 625.54]

625.54 Ground-Fault Circuit-Interrupter Protection for Personnel.

All receptacles and ~~outlets installed~~ hard-wired outlets (utilization equipment) installed for the connection of electric vehicle charging shall have ground-fault circuit-interrupter protection for personnel. The GFCI protection shall be required even if the manufacturer's instructions state otherwise.

Statement of Problem and Substantiation for Public Comment

The propose revision and new sentence clarify that GFCI protection is always required and override the manufacturer's instructions.

Related Item

- PI #1440

Submitter Information Verification

Submitter Full Name: James Stallcup

Organization: Stallcup Electrical Education

Affiliation: Stallcup Electrical Education

Street Address:

City:

State:

Zip:

Submittal Date: Wed Aug 28 18:14:54 EDT 2024

Committee: NEC-P12



Public Comment No. 227-NFPA 70-2024 [Section No. 625.54]

625.54 Ground-Fault Circuit-Interrupter Protection for (GFCI) or Special Purpose Ground-Fault Circuit-Interrupter (SPGFCI) Protection for Personnel. ~~All receptacles and outlets installed for the connection of~~ **(A) Cord-and-Plug Connected.** All receptacles rated 150 volts or less to ground, installed for electric vehicle charging shall have GFCI for personnel protection. ~~All receptacles rated greater than 150 volts to ground, fault circuit interrupter protection for personnel, shall have~~ SPGFCI with a ground-fault trip current not exceeding 20mA for personnel protection.
Exception No. 1: GFCI protection or SPGFCI with a ground-fault trip current not exceeding 20mA shall not be required for a nonlocking, 2-pole, 3-wire grounding-type receptacle outlet rated at 60 volts dc maximum, 15 or 20 amperes as permitted in 625.44(A)(4).
(B) Permanently Wired. All outlets installed for permanently wired electric vehicle charging, greater than 150 volts, shall have SPGFCI with a ground-fault trip current not exceeding 20mA for personnel protection.
Exception No. 1: GFCI protection per 210.8(F) is not required for outlets installed outdoors for permanently wired connected electrical charging equipment.

Statement of Problem and Substantiation for Public Comment

The purpose of this Public Comment is to revise the proposed language to address the requirement of GFCI and SPGFCI protection for both Cord-and-Plug and Direct-Wired connected electrical vehicle charging and dc voltages.

This Public Comments removes "and outlets" since a study for compatibility between direct-wired EVSE and the GFCI is needs to be completed. Unwanted tripping is currently occurring with direct-wired electrical vehicle chargers and the vehicle with the GFCI installed as part of the GFCI in the panelboard.

The use of SPGFCI is expanding throughout the code to avoid unwanted tripping of the GFCI. A subsection for "Direct-Wired" was added to require SPGFCI protection. SPGFCI has a trip level of 20 mA. SPGFCI also is required by it's listing (UL 943C) to monitor the ground path of the circuit and if there is a loss of grounding the SPGFCI will de-energies the load. Because of this feature it provides a safe operation and protection for personnel while preventing unwanted tripping.

Additionally, an exception for direct current EVPTSE is included as UL 943 doesn't apply to direct current.

Related Item

- FR 8378

Submitter Information Verification

Submitter Full Name: David Kendall
Organization: ABB Inc.
Street Address:
City:
State:
Zip:
Submittal Date: Wed Jul 24 10:49:47 EDT 2024
Committee: NEC-P12



Public Comment No. 275-NFPA 70-2024 [Section No. 625.54]

625.54 Ground-Fault Circuit-Interrupter Protection for Personnel.

All ~~receptacles and outlets installed~~ receptacles installed for the connection of electric vehicle charging shall have ground-fault circuit-interrupter protection for personnel.

Additional Proposed Changes

<u>File Name</u>	<u>Description</u>	<u>Approved</u>
315522135_562375592318221_2186616584159142738_n.1688922631723_1_.jpg	Manufacturer's instructions for Tesla directly align with the current language.	

Statement of Problem and Substantiation for Public Comment

There is currently no technical merit to add the word outlet to this reference. The public input to completely delete this reference was resolved which would make 625.54 supplement or modify 210.8. There has been no statistics or any safety concerns with EVSE connected to outlets causing death or injury. The manufacturers are following the UL standard by providing personnel protection that is compatible with their equipment adding the word outlet will complicate the installations of EVSE.

Related Public Comments for This Document

<u>Related Comment</u>	<u>Relationship</u>
Public Comment No. 1737-NFPA 70-2024 [Section No. 210.8(D)]	

Related Item

- 210.8(A)-(F) Exception #6 PI #3158

Submitter Information Verification

Submitter Full Name: William Snyder
Organization: RCC Solutions
Affiliation: High Voltage Live Podcast
Street Address:
City:
State:
Zip:
Submittal Date: Fri Jul 26 19:50:42 EDT 2024
Committee: NEC-P12



Public Comment No. 436-NFPA 70-2024 [Section No. 625.54]

625.54 Ground-Fault Circuit-Interrupter Protection for Personnel.

All receptacles ~~and outlets~~ installed for the connection of electric vehicle charging shall have ground-fault circuit-interrupter protection for personnel.

Statement of Problem and Substantiation for Public Comment

Per Article 625.6 (625.2 in the 2026 first draft), EVSEs shall be listed according to UL 2594 or UL 2202. As part of the listing certification requirement, EVSEs are tested in accordance to UL 2231-1, -2, the UL standard for Personnel Protection Systems for Electric Vehicle Supply Circuits, as referenced per UL 2594 clause 9.2 UL 2202 clause 9.1.1, and article 625.22. This requires EVSEs to have ground fault personnel protection called a charging current interrupting device (CCID) or isolation monitors (IMI) to detect and interrupt in case of ground fault or loss of isolation respectively. The requirement to add GFCI protection for outlets supplying dedicated permanently connected EVSEs is not necessary, redundant, and impractical for DC isolated EVCE.

Furthermore, an outlet for hardwired, or permanently connected EVSE does not pose the same risk a receptacle. The output socket (terminals) of the vehicle connector are not energized until they are fully mated to the EV inlet. Once mated, the terminals are no longer accessible and energization will only occur after the EVSE successfully performs a series of checks required by the standards used to obtain the listing.

Requiring GFCIs for outlets would make it impractical to operate DC Fast Charge (DCFC) EVSEs. DCFCs typically operate at over 350kW of power (~250 hair dryers), and having an outlet with a 5mA GFCI intended for household appliances is not realistic for such high power equipment.

In conclusion, the 2023 code of 625.54 should be reinstated without any changes.

Related Item

- FR-8378

Submitter Information Verification

Submitter Full Name: Indra Wiryadinata

Organization: Tesla

Street Address:

City:

State:

Zip:

Submittal Date: Tue Jul 30 17:01:37 EDT 2024

Committee: NEC-P12



Public Comment No. 53-NFPA 70-2024 [Section No. 625.54]

625.54 Ground-Fault Circuit-Interrupter ~~Protection for Personnel~~: (GFCI) and Special Purpose Ground-Fault Circuit-Interrupter (SPGFCI) Protection

All receptacles and outlets installed for the connection of electric vehicle charging shall have GFCI or SPGFCI protection in accordance with 625.54(A) or 625.54(B).

(A) Branch circuits supplied by circuits less than 150 volts to ground-fault-circuit-interrupter protection for personnel:

____(1) Rated 60 amps or less, single-phase

____(2) Rated 100 amps or less, three-phase

(B) Branch circuits supplied by circuits exceeding 150 volts to ground.

Circuits operating above 150 volts to ground, but not exceeding 480 volts phase to phase, single or three-phase shall be provided with SPGFCI protection.

Statement of Problem and Substantiation for Public Comment

625.4 permits voltages that exceed 150 volts to ground to supply EV charging equipment. GFCI protection is only available for use on circuits that do not exceed 150 volts to ground.

Related Item

• Public Input No. 1372-NFPA 70-2023

Submitter Information Verification

Submitter Full Name: Don Ganiere

Organization: none

Street Address:

City:

State:

Zip:

Submittal Date: Sat Jul 13 14:05:42 EDT 2024

Committee: NEC-P12



Public Comment No. 703-NFPA 70-2024 [Section No. 625.54]

625.54 Ground-Fault Circuit-Interrupter Protection for Personnel.

All receptacles and outlets installed for the connection of electric vehicle charging shall have ground-fault circuit-interrupter protection for personnel.

Exception: Outlets installed for connection of EVPE that utilizes the branch circuit conductors for power export does not require GFCI protection until January 1, 2029.

Statement of Problem and Substantiation for Public Comment

There are not GFCI devices available on the market that support reverse feeding and therefore, the requirements of the first draft are incompatible with bidirectional equipment. This PC provides addition time for GFCI products to be developed to facilitate bidirectional current flow.

Related Item

- First Revision No. 8378-NFPA 70-2024 [Section No. 625.54]

Submitter Information Verification

Submitter Full Name: John Cowans

Organization: Siemens

Street Address:

City:

State:

Zip:

Submittal Date: Fri Aug 02 13:53:52 EDT 2024

Committee: NEC-P12



Public Comment No. 98-NFPA 70-2024 [Section No. 625.54]

625.54 Ground-Fault Circuit-Interrupter Protection for Personnel.

~~All receptacles and outlets~~

~~Ground-fault circuit-interrupter protection shall only be required for receptacles installed for the connection of electric vehicle charging~~

~~shall have ground-fault circuit-interrupter protection for personnel~~

.

Statement of Problem and Substantiation for Public Comment

Point 1. My revised text is to ensure that none of the rules contained in 210.8 apply EVSE and that this CMP decides what GFCI protection should be provided. Just like the RV Park rules.

Point 2. I think you guys (includes the ladies) are shooting yourselves in the foot with the change in the first draft for the following reasons:

1. EV charging manufacture instructions often specify to NOT provide GFCI protection.
2. GFCI's are not available for over 150V-to-ground systems. So this rule cannot be complied with for EV charges operating at 277/480V circuits.
3. The rule will also require three-phase GFCIs, now you are talking big bucks...
4. The cost for a 100A 120/240V GFCI is a fortune... like over a thousand dollars. Remember you can't get a GFCI for a 277/480V circuit.

Related Item

- 8378

Submitter Information Verification

Submitter Full Name: Mike Holt

Organization: Mike Holt Enterprises Inc

Street Address:

City:

State:

Zip:

Submittal Date: Tue Jul 16 18:17:57 EDT 2024

Committee: NEC-P12



Public Comment No. 1488-NFPA 70-2024 [Section No. 626.30(C)]

~~(G) Special Purpose Ground-Fault-Circuit-Interrupter (SPGFCI) Protection for Personnel:~~

~~The electrified truck parking space equipment intended to supply transport refrigerated units shall be designed and constructed such that all receptacle outlets in 626.30, supplied by branch circuits that are rated more than 150 volts to ground, 100 amperes or less, shall be provided with SPGFCI protection for personnel.~~

~~This requirement shall become effective January 1, 2029.~~

Statement of Problem and Substantiation for Public Comment

Adding this requirement without alarm or notification will result in unknown spoiled food and potential serious impact to humans, beyond what this hopes to address.

UL, NEC, and CDC would all need to work together to create a GFCI system that would protect the worker, but also protect the people eating the food from series food poisoning / ebola / salmonella etc.

Additional attention needs to be paid to the food waste impact that could occur due to false trips of GFCI. Depending on the user reporting false trips could lead to large spoilage events when refrigeration units are unintentionally not running for long periods of time.

Related Item

- FR8406

Submitter Information Verification

Submitter Full Name: Joel Goergen

Organization: Cisco Systems, Inc.

Affiliation: Cisco Systems, Inc.

Street Address:

City:

State:

Zip:

Submittal Date: Fri Aug 23 14:59:55 EDT 2024

Committee: NEC-P12



Public Comment No. 647-NFPA 70-2024 [Section No. 626.32]

626.32 Power Supply Cable Assembly.

A separable power supply cable assembly, consisting of a cord with an attachment plug and cord connector, shall be one of the types and ratings specified in 626.32(A), 626.32(B), and 626.32(C). Cords with adapters and pigtail ends, extension cords, and similar items shall not be used.

A permanently connected power supply cable assembly, consisting of a cord with a cord connector, shall be one of the types and rating specified in 626.32(A), 626.32(B), and 626.32(C).

The power supply cable assembly shall be provided with an integral breakaway means that prevents physical damage or rupture, in the event of a drive-away, at the attachment plug's or connector's connection to the respective receptacle or inlet.

(A) Rating(s).

The power supply cable assembly shall be listed and rated in accordance with one of the following:

- (1) A 30-ampere, 480-volt, 3-phase assembly
- (2) A 60-ampere, 208-volt, 3-phase assembly
- (3) A 20-ampere, 1000-volt, 3-phase assembly
- (4) A 60-ampere, 480-volt, 3-phase assembly
- (5) A 60-ampere, 250-volt, 3-phase assembly

(B) Cord Sets or Cable Assemblies.

The cord shall be a listed type with four conductors, for 3-phase connection, one of which shall be identified in accordance with 400.23 for use as the equipment grounding conductor. Extra-hard usage cables rated not less than 90°C (194°F), 600 volts, listed for both wet locations and sunlight resistance, and having an outer jacket rated to be resistant to temperature extremes, oil, gasoline, ozone, abrasion, acids, and chemicals, shall be permitted where flexibility is necessary between the electrified truck parking space supply equipment and the inlet(s) on the TRU.

(C) Attachment Plug(s) and Cord Connector(s).

Where a flexible cord is provided with an attachment plug or cord connector, they shall comply with 250.138(A). The attachment plug(s) or cord connector(s) shall be listed, by itself or as part of the power-supply cord assembly, for the purpose and shall be molded to or installed on the flexible cord so that it is secured tightly to the cord at the point where the cord enters the attachment plug or cord connector. If a right-angle cap is used, the configuration shall be oriented so that the grounding member is farthest from the cord. An attachment plug or cord connector for the connection of a truck or trailer shall be rated in accordance with one of the following:

- (1) 30-ampere, 480-volt, 3-phase, 3-pole, 4-wire and intended for use with 30-ampere, 480-volt, 3-phase, 3-pole, 4-wire receptacles and inlets, respectively
- (2) 60-ampere, 208-volt, 3-phase, 3-pole, 4-wire and intended for use with 60-ampere, 208-volt, 3-phase, 3-pole, 4-wire receptacles and inlets, respectively
- (3) 20-ampere, 1000-volt, 3-phase, 3-pole, 4-wire and intended for use with 20-ampere, 1000-volt, 3-phase, 3-pole, 4-wire receptacles and inlets, respectively
- (4) 60-ampere, 480-volt, 3-phase, 3-pole, 4-wire and intended for use with 60-ampere, 480-volt, 3-phase, 3-pole, 4-wire receptacles and inlets, respectively
- (5) 60-ampere, 250-volt, 3-phase, 3-pole, 4-wire and intended for use with 60-ampere, 250-volt, 3-phase, 3-pole, 4-wire receptacles and inlets, respectively

Informational Note: See UL 1686-2012, *Pin and Sleeve Configurations*, Figures C2.12 and C2.11, for complete details of the 30-ampere pin and sleeve receptacle configuration for refrigerated containers (TRUs) and for various configurations of 60-ampere pin and sleeve receptacles.

Additional Proposed Changes

<u>File Name</u>	<u>Description</u>	<u>Approved</u>
CN_345.pdf		

Statement of Problem and Substantiation for Public Comment

NOTE: The following CC Note No. 345 appeared in the First Draft Report on First Revision No. 8423.

The listing requirements for the power supply cable assembly in this section shall be moved to 626.2 in accordance with the NEC® Style Manual Section 2.2.1.

Related Item

- First Revision No. 8423

Submitter Information Verification

Submitter Full Name: CC Notes

Organization: NEC Correlating Committee

Street Address:

City:

State:

Zip:

Submittal Date: Fri Aug 02 09:04:57 EDT 2024

Committee: NEC-P12



Correlating Committee Note No. 345-NFPA 70-2024 [Section No. 626.32]

Submitter Information Verification

Committee: NEC-AAC

Submittal Date: Fri May 10 08:06:03 EDT 2024

Committee Statement

Committee Statement: The listing requirements for the power supply cable assembly in this section shall be moved to 626.2 in accordance with the NEC® Style Manual Section 2.2.1.

First Revision No. 8423-NFPA 70-2024 [Section No. 626.32]

Ballot Results

✓ **This item has passed ballot**

12 Eligible Voters

1 Not Returned

11 Affirmative All

0 Affirmative with Comments

0 Negative with Comments

0 Abstention

Not Returned

McDaniel, Roger D.

Affirmative All

Ayer, Lawrence S.

Bowmer, Trevor N.

Hickman, Palmer L.

Holub, Richard A.

Jackson, Peter D.

Kendall, David H.

Manche, Alan

Osborne, Robert D.

Porter, Christine T.

Schultheis, Timothy James

Williams, David A.



Article 627 Electric Self-Propelled and Unpropelled Vehicle Power Transfer Systems (ESVSEs)

Part I. General

627.1 Scope.

This article covers the electrical conductors and equipment connecting ~~an a portable, electricity generating household appliance and an~~ electric self-propelled ~~vehicle or an unpropelled vehicle~~ (ESV) ~~to~~ to premises wiring for the purposes of charging, power export, or bidirectional current flow.

627.2 Listing Requirements.

Electric self-propelled or unpropelled vehicle or portable electricity generating household appliance supply equipment (ESVSE), including power supply cords for the purposes of charging, power export, or bidirectional current flow, shall be listed.

627.4 Voltages.

Unless other voltages are specified, the nominal ac system voltages of 120, 120/240, 208Y/120, 240, 480Y/277, 480, 600Y/347, 600, or 1000 volts or dc system input voltages of up to 1000 volts shall be used to supply equipment covered by Article 627.

Output voltages to the ESV are not specified.

Part II. Equipment Construction

627.17 Cords and Cables.

(A) Power-Supply Cords.

Cables for cord-connected ESVSE shall comply with all of the following:

- (1) Be any of the types specified in 627.17(B)(1) or hard service cord, junior hard service cord, or portable power cable types in accordance with Table 400.4. Hard service cord, junior hard service cord, or portable power cable types shall be listed, as applicable, for exposure to oil and damp and wet locations.
- (2) Have an ampacity as specified in Table 400.5(A)(1) or, for 8 AWG and larger, in the 60°C (140°F) columns of Table 400.5(A)(2)
- (3) Have an overall length as specified in either of the following:
 - a. When the interrupting device of the personnel protection system specified in 627.22 is located within the enclosure of the supply equipment or charging system, the power-supply cord is not more than indicated in either of the following:
 - (4) For portable equipment in accordance with 627.44(A), not more than 300 mm (12 in.) long
 - (5) For fastened-in-place equipment in accordance with 627.44(B) 627.44(B), not more than 1.8 m (6 ft) long, with equipment installed at a height that prevents the power-supply cord from contacting the floor when it is connected to the proper receptacle
 - b. When the interrupting device of the personnel protection system specified in 627.22 is located at the attachment plug, or within the first 300 mm (12 in.) of the power-supply cord, not more than 4.6 m (15 ft) long

(B) Output Cables to ESV.

Output cables to ESVs shall be either of the following

- (1) Listed Types EV, EVJ, EVE, EVJE, EVT, or EVJT flexible cables as specified in Table 400.4
- (2) Integral parts of listed ESVSE

(C) Overall Cord and Cable Length.

Overall usable length shall not exceed 7.5 m (25 ft) unless equipped with a cable management system that is part of the listed ESVSE.

(1) Portable Equipment.

For portable ESVSE, cord-exposed usable length shall be measured from the face of attachment plugs to the face of ESV connectors.

(2) Fastened-in-Place.

(a) Where ESVSE is fastened-in-place, the usable length of output cables to ESVs shall be measured from the cable exits of the ESVSE to the face of ESV connectors.

(b) Where wireless power transfer equipment (WPTE) is fastened-in-place, the output cables to the primary pads shall be measured from the cable exits of the control boxes to the cable inlets at the primary pads.

(D) Interconnecting Cabling Systems.

Other cabling systems that are integral parts of listed supply equipment and are intended to interconnect pieces of equipment within ESVSE systems using approved installation methods shall be permitted.

627.22 Personnel Protection Systems.

ESVSE shall have a listed system of protection against electric shock of personnel and comply with the following:

- (1) Where cord-and-plug-connected equipment is used, the interrupting device of a listed personnel protection system shall be provided according to 627.17(A).
- (2) A personnel protection system shall not be required for power transfer equipment that supplies less than 60 volts dc.

Part III. Installation

627.40 ESVSE Branch Circuits.

Each outlet installed for the purpose of supplying ESVSE greater than 16 amperes, or 120 volts, shall be supplied by an individual branch circuit.

Exception: Branch circuits shall be permitted to feed multiple ESVSE as permitted by 627.42(A) or 627.42(B).

627.41 Overcurrent Protection.

(A) General.

Overcurrent protection for feeders and branch circuits supplying ESVSE and WPTE, including bidirectional equipment, shall be sized for continuous duty and have a current rating of not less than 125 percent of the maximum load of the equipment.

(B) Noncontinuous Loads.

Where noncontinuous loads are supplied from the same feeder, overcurrent devices shall have current ratings of not less than the sum of the noncontinuous loads plus 125 percent of the continuous loads.

627.42 Rating.

ESVSE shall have sufficient rating to supply the load served. Charging loads shall be considered continuous loads for the purposes of this article. Service and feeders shall be sized in accordance with the product ratings, unless the overall rating of the installation can be limited through controls as permitted by 627.42(A) or 627.42(B).

(A) Energy Management System (EMS).

Where energy management systems (EMSs) in accordance with 130.30 provide load management of ESVSE, the maximum equipment load on service and feeders shall be the maximum load permitted by the EMS. EMSs shall be permitted to be integral to one piece of equipment or integral to listed systems consisting of more than one piece of equipment. When one or more pieces of equipment are provided with integral load management control, systems shall be marked to indicate such control is provided.

(B) Supply Equipment with Adjustable Settings.

Supply equipment with restricted access to an ampere adjusting means complying with 130.30(C) shall be permitted. If adjustments have an impact on the rating label, such changes shall comply with manufacturer's instructions, with the adjusted rating appearing on the rating label with sufficient durability to withstand the environment involved. Such supply equipment shall be permitted to have ampere ratings that are equal to the adjusted current setting.

627.43 Disconnecting Means.

Supply equipment rated more than 60 amperes or more than 150 volts to ground shall be provided with a disconnecting means installed in a readily accessible location. If the disconnecting means is installed remote from the equipment, a plaque shall be installed on the equipment denoting the location of the disconnecting means. The disconnecting means shall be lockable open in accordance with 110.25.

627.44 Equipment Connection.

ESVSE and WPTE shall be connected to the premises wiring system in accordance with one of the methods in 627.44(A) through 627.44(C).

(A) Portable Equipment.

Portable equipment shall be connected to the premises wiring system by one or more of the following methods:

- (1) A nonlocking, 2-pole, 3-wire grounding-type receptacle outlet rated at 125 volts, single phase, 15 or 20 amperes
- (2) A nonlocking, 2-pole, 3-wire grounding-type receptacle outlet rated at 250 volts, single phase, 15 or 20 amperes
- (3) A nonlocking, 2-pole, 3-wire or 3-pole, 4-wire grounding-type receptacle outlet rated at 250 volts, single phase, 30 or 50 amperes, or at 125/250 volts, single-phase, 30, 50, or 60 amperes
- (4) A nonlocking, 2-pole, 3-wire grounding-type receptacle outlet rated at 60 volts dc maximum, 15 or 20 amperes

(B) Fastened-in-Place Equipment.

Equipment that is fastened-in-place shall be connected to the premises wiring system by one of the following methods:

- (1) A nonlocking, 2-pole, 3-wire grounding-type receptacle outlet rated 125 volts or 250 volts, single phase, up to 50 amperes
- (2) A nonlocking, 3-pole, 4-wire grounding-type receptacle outlet rated 250 volts, three phase, up to 50 amperes
- (3) A nonlocking, 3-pole, 4-wire grounding-type receptacle outlet rated 125/250 volts, single phase, 30, 50, or 60 amperes
- (4) A nonlocking, 2-pole, 3-wire grounding-type receptacle outlet rated 60 volts dc maximum, 15 or 20 amperes

(C) Fixed-in-Place Equipment.

All other ESVSE and WPTE shall be permanently wired and fixed-in-place to supporting surfaces.

627.46 Loss of Primary Source.

Means shall be provided such that energy cannot be backfed through the ESV and supply equipment to the premises wiring system upon loss of voltage from the utility or other electrical systems unless permitted by 627.48.

627.47 Multiple Feeder or Branch Circuits.

Where equipment is identified for the application, more than one feeder or branch circuit shall be permitted to supply equipment.

627.48 Interactive Equipment.

ESVSE or WPTE that incorporates power export functions and are part of interactive systems that serve as optional standby systems, electric power production sources, or bidirectional power feeds shall be listed and marked as suitable for that purpose. When ESVSE or WPTE are used as optional standby systems, the requirements of Article 702, Parts I and II, shall apply; when ESVSE or WPTE are used as electric power production sources, the requirements of Article 705, Parts I and II, shall apply. Electric vehicle power export equipment (EVPE) that provide receptacle outlets as points of power export shall comply with 627.60.

627.49 Island Mode.

Electric self-propelled vehicle power export equipment (ESVPE) and bidirectional ESVSE that incorporate power export functions shall be permitted to be part of interconnected power systems operating in island mode.

627.50 Location.

ESVSE shall be located for direct electrical coupling of ESV connectors (conductive or inductive) to ESVs. Unless specifically listed and marked for the location, the coupling means of ESVs shall be stored or located at a height of not less than 450 mm (18 in.) above the floor level for indoor locations or 600 mm (24 in.) above the grade level for outdoor locations.

This requirement shall not apply to portable ESVSE constructed in accordance with 627.44(A).

627.52 Ventilation.

Ventilation for charging ESVs in indoor enclosed spaces shall be determined by 627.52(A) or 627.52(B).

(A) Ventilation Not Required.

Where ESV storage batteries are used or where equipment is listed for charging ESVs indoors without ventilation, mechanical ventilation shall not be required.

(B) Ventilation Required.

Where equipment is listed for charging ESVs that require ventilation for indoor charging, mechanical ventilation shall be provided. The ventilation shall include both supply and exhaust equipment and shall be permanently installed and located to intake from, and vent directly to, the outdoors. Positive-pressure ventilation systems shall be permitted only in vehicle charging buildings or areas that have been specifically designed and approved for that application. Mechanical ventilation requirements shall be determined by one of the methods specified in 627.52(B)(1) through 627.52(B)(4).

Informational Note: An example of mechanical ventilation would be a fan.

(1) Table Values.

For supply voltages and currents specified in Table 627.52(B)(1)(1) or Table 627.52(B)(1)(2), the minimum ventilation requirements shall be as specified in Table 627.52(B)(1)(1) or Table 627.52(B)(1)(2) for each of the total number of electric vehicles that can be charged at one time.

Table 627.52(B)(1)(1) Minimum Ventilation Required in Cubic Meters per Minute (m³/min) for Each of the Total Number of ESVs That Can Be Charged at One Time

Branch-Circuit Ampere Rating	Branch-Circuit Voltage								
	Single-Phase					3-Phase			
	DC	240 V or				208 V or	480 V or		600 V or
	≥ 50 V	120 V	208 V	120/240 V	208Y/120 V	240 V	480Y/277 V	600Y/347 V	
15	0.5	1.1	1.8	2.1	-	—	—	—	—
20	0.6	1.4	2.4	2.8	-	4.2	4.8	9.7	12
30	0.9	2.1	3.6	4.2	-	6.3	7.2	15	18
40	1.2	2.8	4.8	5.6	-	8.4	9.7	19	24
50	1.5	3.5	6.1	7	-	10	12	24	30
60	1.8	4.2	7.3	8.4	-	13	15	29	36
100	2.9	7	12	14	-	21	24	48	60
150	—	—	—	—	-	31	36	73	91
200	—	—	—	—	-	42	48	97	120
250	—	—	—	—	-	52	60	120	150
300	—	—	—	—	-	63	73	145	180
350	—	—	—	—	-	73	85	170	210
400	—	—	—	—	-	84	97	195	240

Table 627.52(B)(1)(2) Minimum Ventilation Required in Cubic Feet per Minute (cfm) for Each of the Total Number of Electric Vehicles That Can Be Charged at One Time

Branch-Circuit Ampere Rating	Branch-Circuit Voltage								
	Single-Phase					3-Phase			
	DC	240 V or				208 V or	480 V or		600 V or
	≥ 50 V	120 V	208 V	120/240 V	208Y/120 V	240 V	480Y/277 V	600Y/347 V	
15	15.4	37	64	74	-	—	—	—	—
20	20.4	49	85	99	-	148	171	342	427
30	30.8	74	128	148	-	222	256	512	641
40	41.3	99	171	197	-	296	342	683	854
50	51.3	123	214	246	-	370	427	854	1066
60	61.7	148	256	296	-	444	512	1025	1281
100	102.5	246	427	493	-	740	854	1708	2135
150	—	—	—	—	-	1110	1281	2562	3203
200	—	—	—	—	-	1480	1708	3416	4270
250	—	—	—	—	-	1850	2135	4270	5338
300	—	—	—	—	-	2221	2562	5125	6406
350	—	—	—	—	-	2591	2989	5979	7473
400	—	—	—	—	-	2961	3416	6832	8541

(2) Other Values.

For supply voltages and currents other than specified in Table 627.52(B)(1)(1) or Table 627.52(B)(1)(2), the minimum ventilation requirements shall be calculated by means of Equation 627.52(B)(2)a or Equation 627.52(B)(2)b for single-phase ac or dc or Equation 627.52(B)(2)c or Equation 627.52(B)(2)d for 3-phase ac.

$$\text{ventilation single-phase ac or dc in cubic meters per minute} \left(\frac{\text{m}^3}{\text{min}} \right) = \frac{(\text{volts})(\text{amperes})}{1718} \quad [627.52(B)(2)a]$$

$$\text{ventilation single-phase ac or dc in cubic feet per minute (cfm)} = \frac{(\text{volts})(\text{amperes})}{48.7} \quad [627.52(B)(2)b]$$

$$\text{ventilation 3-phase ac or dc in cubic meters per minute} \left(\frac{\text{m}^3}{\text{min}} \right) = \frac{(1.732)(\text{volts})(\text{amperes})}{1718} \quad [627.52(B)(2)c]$$

$$\text{ventilation 3-phase ac or dc in cubic feet per minute (cfm)} = \frac{(1.732)(\text{volts})(\text{amperes})}{48.7} \quad [627.52(B)(2)d]$$

(3) Engineered Systems.

For equipment ventilation systems designed by persons qualified to perform such calculations as integral parts of total ventilation systems for buildings, minimum ventilation requirements shall be permitted to be determined in accordance with calculations specified in engineering studies.

(4) Supply Circuits.

Supply circuits to mechanical ventilation equipment shall be electrically interlocked with the equipment and remain energized during the entire electric vehicle charging cycle. Equipment receptacles rated at 125 volts, single phase, 15 and 20 amperes shall be switched, with mechanical ventilation systems electrically interlocked through the switch supply power to the receptacles. Equipment supplied from less than 50 volts dc shall be switched with mechanical ventilation systems electrically interlocked through the switch supply power to the equipment.

627.54 Ground-Fault Circuit-Interrupter Protection for Personnel.

All receptacles installed for the connection of ESVSE shall have GFCI protection for personnel.

627.56 Receptacle Enclosures.

All receptacles installed in wet locations for electric vehicle charging shall have enclosures that are weatherproof with attachment plug caps inserted or removed. Outlet box hoods installed for this purpose shall be listed and be identified as extra duty. Other listed products, enclosures, or assemblies providing weatherproof protection that do not use outlet box hoods shall not be required to be marked extra duty.

Part IV. Wireless Power Transfer Equipment

627.101 Grounding.

Primary pad base plates shall be constructed of nonferrous metal and be connected to circuit equipment grounding conductors unless the listed WPTE employs double-insulation systems. Base plates shall be sized to match the size of the primary pad enclosures.

627.102 Installation.

(A) General.

Control pads, if included in WPTE configuration, shall comply with 627.102(B). The primary pad shall comply with 627.102(C).

(B) Control Box.

Control box enclosures shall be suitable for the environment and be mounted at a height not less than 450 mm (18 in.) above the floor level for indoor locations or 600 mm (24 in.) above grade level for outdoor locations in one of the following forms:

- (1) Pedestals
- (2) Walls or poles
- (3) Buildings or structures
- (4) Raised concrete pads

(C) Primary Pads.

Primary pads shall be installed secured to the surface or embedded in the surface of the floor with their tops flush with or below the surface in accordance with the manufacturer's instructions and the following:

- (1) If located in an area requiring snow removal, primary pads shall not be located on or above the surface.
Exception: Where installed on private property where snow removal is done manually, primary pads shall be permitted to be installed on or above the surface.
- (2) Primary pad enclosures shall be suitable for the environment and, if located in an area subject to severe climatic conditions (e.g., flooding), suitably rated for those conditions.

(D) Protection of Cords and Cables to Primary Pads.

Output cables to primary pads shall be secured in place over its entire length to restrict movement and to prevent strain at the connection points. If installed in conditions where drive-over could occur, cables shall be provided with supplemental protection.

Where control boxes are not provided, cords or cables supplying power to primary pads shall be secured in place to restrict movement and to prevent strain at the connection points. Where subject to vehicular traffic, supplemental protection shall be provided.

(E) Other Wiring Systems.

Other wiring systems and fittings specifically listed for use on WPTE shall be permitted.

Statement of Problem and Substantiation for Public Comment

Merriam-Webster defines a vehicle as "a means of carrying or transporting something."

However, the current language in the National Electric Code (NEC) excludes unpropelled vehicles, such as solar and battery trailers and carts, as well as portable electricity-generating household appliances. This exclusion lacks a scientifically sound rationale.

Unpropelled vehicles like carts, trailers, and cord-connected electricity-generating household appliances should be considered within the NEC's scope as Electric Vehicles (EVs). Without a compliant pathway through codes and standards, the market will likely continue to see the rise of "guerrilla" style solar and storage battery products. These products, thriving in today's dynamic online marketplace, set the pace outside established regulatory frameworks.

By clarifying the regulatory grey areas for mobile, grid-interconnected plug-in equipment, we can establish an unambiguous framework that significantly enhances safety in contrast to the the current "guerrilla style" installations.

Including all "plug-in" vehicles, portable devices, and equipment within the NEC will allow us to legally support a safe and smart, interconnected future electric grid by fully including all bidirectional Distributed Energy Resources (DERs). This inclusion would enable lower- and moderate-income prosumers to participate in the electricity market, creating valid economic opportunities for these underserved communities. Additionally, it would incentivize manufacturers to certify their products, thereby improving consumer protection.

Related Item

- Global FR 9093

Submitter Information Verification

Submitter Full Name: Achim Ginsberg-Klemmt

Organization: GismoPower LLC

Affiliation: GismoPower LLC

Street Address:

City:

State:

Zip:

Submittal Date: Fri Aug 16 22:12:48 EDT 2024

Committee: NEC-P12



~~Article 627~~

-

Article 624 Electric Self-Propelled Vehicle Power Transfer Systems (ESVSEs)

Part I. General

627.1 Scope.

This article covers the electrical conductors and equipment connecting an electric self-propelled vehicle (ESV) to premises wiring for the purposes of charging, power export, or bidirectional current flow.

627.2 Listing Requirements.

Electric self-propelled vehicle supply equipment (ESVSE), including power supply cords for the purposes of charging, power export, or bidirectional current flow, shall be listed.

627.4 Voltages.

Unless other voltages are specified, the nominal ac system voltages of 120, 120/240, 208Y/120, 240, 480Y/277, 480, 600Y/347, 600, or 1000 volts or dc system input voltages of up to 1000 volts shall be used to supply equipment covered by Article 627.

Output voltages to the ESV are not specified.

Part II. Equipment Construction

627.17 Cords and Cables.

(A) Power-Supply Cords.

Cables for cord-connected ESVSE shall comply with all of the following:

- (1) Be any of the types specified in 627.17(B)(1) or hard service cord, junior hard service cord, or portable power cable types in accordance with Table 400.4. Hard service cord, junior hard service cord, or portable power cable types shall be listed, as applicable, for exposure to oil and damp and wet locations.
- (2) Have an ampacity as specified in Table 400.5(A)(1) or, for 8 AWG and larger, in the 60°C (140°F) columns of Table 400.5(A)(2)
- (3) Have an overall length as specified in either of the following:
 - a. When the interrupting device of the personnel protection system specified in 627.22 is located within the enclosure of the supply equipment or charging system, the power-supply cord is not more than indicated in either of the following:
 - (4) For portable equipment in accordance with 627.44(A), not more than 300 mm (12 in.) long
 - (5) For fastened-in-place equipment in accordance with 627.44(B) 627.44(B), not more than 1.8 m (6 ft) long, with equipment installed at a height that prevents the power-supply cord from contacting the floor when it is connected to the proper receptacle
 - b. When the interrupting device of the personnel protection system specified in 627.22 is located at the attachment plug, or within the first 300 mm (12 in.) of the power-supply cord, not more than 4.6 m (15 ft) long

(B) Output Cables to ESV.

Output cables to ESVs shall be either of the following

- (1) Listed Types EV, EVJ, EVE, EVJE, EVT, or EVJT flexible cables as specified in Table 400.4
- (2) Integral parts of listed ESVSE

(C) Overall Cord and Cable Length.

Overall usable length shall not exceed 7.5 m (25 ft) unless equipped with a cable management system that is part of the listed ESVSE.

(1) Portable Equipment.

For portable ESVSE, cord-exposed usable length shall be measured from the face of attachment plugs to the face of ESV connectors.

(2) Fastened-in-Place.

(a) Where ESVSE is fastened-in-place, the usable length of output cables to ESVs shall be measured from the cable exits of the ESVSE to the face of ESV connectors.

(b) Where wireless power transfer equipment (WPTE) is fastened-in-place, the output cables to the primary pads shall be measured from the cable exits of the control boxes to the cable inlets at the primary pads.

(D) Interconnecting Cabling Systems.

Other cabling systems that are integral parts of listed supply equipment and are intended to interconnect pieces of equipment within ESVSE systems using approved installation methods shall be permitted.

627.22 Personnel Protection Systems.

ESVSE shall have a listed system of protection against electric shock of personnel and comply with the following:

- (1) Where cord-and-plug-connected equipment is used, the interrupting device of a listed personnel protection system shall be provided according to 627.17(A).
- (2) A personnel protection system shall not be required for power transfer equipment that supplies less than 60 volts dc.

Part III. Installation

627.40 ESVSE Branch Circuits.

Each outlet installed for the purpose of supplying ESVSE greater than 16 amperes, or 120 volts, shall be supplied by an individual branch circuit.

Exception: Branch circuits shall be permitted to feed multiple ESVSE as permitted by 627.42(A) or 627.42(B).

627.41 Overcurrent Protection.

(A) General.

Overcurrent protection for feeders and branch circuits supplying ESVSE and WPTE, including bidirectional equipment, shall be sized for continuous duty and have a current rating of not less than 125 percent of the maximum load of the equipment.

(B) Noncontinuous Loads.

Where noncontinuous loads are supplied from the same feeder, overcurrent devices shall have current ratings of not less than the sum of the noncontinuous loads plus 125 percent of the continuous loads.

627.42 Rating.

ESVSE shall have sufficient rating to supply the load served. Charging loads shall be considered continuous loads for the purposes of this article. Service and feeders shall be sized in accordance with the product ratings, unless the overall rating of the installation can be limited through controls as permitted by 627.42(A) or 627.42(B).

(A) Energy Management System (EMS).

Where energy management systems (EMSs) in accordance with 130.30 provide load management of ESVSE, the maximum equipment load on service and feeders shall be the maximum load permitted by the EMS. EMSs shall be permitted to be integral to one piece of equipment or integral to listed systems consisting of more than one piece of equipment. When one or more pieces of equipment are provided with integral load management control, systems shall be marked to indicate such control is provided.

(B) Supply Equipment with Adjustable Settings.

Supply equipment with restricted access to an ampere adjusting means complying with 130.30(C) shall be permitted. If adjustments have an impact on the rating label, such changes shall comply with manufacturer's instructions, with the adjusted rating appearing on the rating label with sufficient durability to withstand the environment involved. Such supply equipment shall be permitted to have ampere ratings that are equal to the adjusted current setting.

627.43 Disconnecting Means.

Supply equipment rated more than 60 amperes or more than 150 volts to ground shall be provided with a disconnecting means installed in a readily accessible location. If the disconnecting means is installed remote from the equipment, a plaque shall be installed on the equipment denoting the location of the disconnecting means. The disconnecting means shall be lockable open in accordance with 110.25.

627.44 Equipment Connection.

ESVSE and WPTE shall be connected to the premises wiring system in accordance with one of the methods in 627.44(A) through 627.44(C).

(A) Portable Equipment.

Portable equipment shall be connected to the premises wiring system by one or more of the following methods:

- (1) A nonlocking, 2-pole, 3-wire grounding-type receptacle outlet rated at 125 volts, single phase, 15 or 20 amperes
- (2) A nonlocking, 2-pole, 3-wire grounding-type receptacle outlet rated at 250 volts, single phase, 15 or 20 amperes
- (3) A nonlocking, 2-pole, 3-wire or 3-pole, 4-wire grounding-type receptacle outlet rated at 250 volts, single phase, 30 or 50 amperes, or at 125/250 volts, single-phase, 30, 50, or 60 amperes
- (4) A nonlocking, 2-pole, 3-wire grounding-type receptacle outlet rated at 60 volts dc maximum, 15 or 20 amperes

(B) Fastened-in-Place Equipment.

Equipment that is fastened-in-place shall be connected to the premises wiring system by one of the following methods:

- (1) A nonlocking, 2-pole, 3-wire grounding-type receptacle outlet rated 125 volts or 250 volts, single phase, up to 50 amperes
- (2) A nonlocking, 3-pole, 4-wire grounding-type receptacle outlet rated 250 volts, three phase, up to 50 amperes
- (3) A nonlocking, 3-pole, 4-wire grounding-type receptacle outlet rated 125/250 volts, single phase, 30, 50, or 60 amperes
- (4) A nonlocking, 2-pole, 3-wire grounding-type receptacle outlet rated 60 volts dc maximum, 15 or 20 amperes

(C) Fixed-in-Place Equipment.

All other ESVSE and WPTE shall be permanently wired and fixed-in-place to supporting surfaces.

627.46 Loss of Primary Source.

Means shall be provided such that energy cannot be backfed through the ESV and supply equipment to the premises wiring system upon loss of voltage from the utility or other electrical systems unless permitted by 627.48.

627.47 Multiple Feeder or Branch Circuits.

Where equipment is identified for the application, more than one feeder or branch circuit shall be permitted to supply equipment.

627.48 Interactive Equipment.

ESVSE or WPTE that incorporates power export functions and are part of interactive systems that serve as optional standby systems, electric power production sources, or bidirectional power feeds shall be listed and marked as suitable for that purpose. When ESVSE or WPTE are used as optional standby systems, the requirements of Article 702, Parts I and II, shall apply; when ESVSE or WPTE are used as electric power production sources, the requirements of Article 705, Parts I and II, shall apply. Electric vehicle power export equipment (EVPE) that provide receptacle outlets as points of power export shall comply with 627.60.

627.49 Island Mode.

Electric self-propelled vehicle power export equipment (ESVPE) and bidirectional ESVSE that incorporate power export functions shall be permitted to be part of interconnected power systems operating in island mode.

627.50 Location.

ESVSE shall be located for direct electrical coupling of ESV connectors (conductive or inductive) to ESVs. Unless specifically listed and marked for the location, the coupling means of ESVs shall be stored or located at a height of not less than 450 mm (18 in.) above the floor level for indoor locations or 600 mm (24 in.) above the grade level for outdoor locations.

This requirement shall not apply to portable ESVSE constructed in accordance with 627.44(A).

627.52 Ventilation.

Ventilation for charging ESVs in indoor enclosed spaces shall be determined by 627.52(A) or 627.52(B).

(A) Ventilation Not Required.

Where ESV storage batteries are used or where equipment is listed for charging ESVs indoors without ventilation, mechanical ventilation shall not be required.

(B) Ventilation Required.

Where equipment is listed for charging ESVs that require ventilation for indoor charging, mechanical ventilation shall be provided. The ventilation shall include both supply and exhaust equipment and shall be permanently installed and located to intake from, and vent directly to, the outdoors. Positive-pressure ventilation systems shall be permitted only in vehicle charging buildings or areas that have been specifically designed and approved for that application. Mechanical ventilation requirements shall be determined by one of the methods specified in 627.52(B)(1) through 627.52(B)(4).

Informational Note: An example of mechanical ventilation would be a fan.

(1) Table Values.

For supply voltages and currents specified in Table 627.52(B)(1)(1) or Table 627.52(B)(1)(2), the minimum ventilation requirements shall be as specified in Table 627.52(B)(1)(1) or Table 627.52(B)(1)(2) for each of the total number of electric vehicles that can be charged at one time.

Table 627.52(B)(1)(1) Minimum Ventilation Required in Cubic Meters per Minute (m³/min) for Each of the Total Number of ESVs That Can Be Charged at One Time

Branch-Circuit Ampere Rating	Branch-Circuit Voltage								
	Single-Phase					3-Phase			
	DC	240 V or			208 V or	480 V or		600 V or	
	≥ 50 V	120 V	208 V	120/240 V	208Y/120 V	240 V	480Y/277 V	600Y/347 V	
15	0.5	1.1	1.8	2.1	—	—	—	—	—
20	0.6	1.4	2.4	2.8	4.2	4.8	9.7	—	12
30	0.9	2.1	3.6	4.2	6.3	7.2	15	—	18
40	1.2	2.8	4.8	5.6	8.4	9.7	19	—	24
50	1.5	3.5	6.1	7	10	12	24	—	30
60	1.8	4.2	7.3	8.4	13	15	29	—	36
100	2.9	7	12	14	21	24	48	—	60
150	—	—	—	—	31	36	73	—	91
200	—	—	—	—	42	48	97	—	120
250	—	—	—	—	52	60	120	—	150
300	—	—	—	—	63	73	145	—	180
350	—	—	—	—	73	85	170	—	210
400	—	—	—	—	84	97	195	—	240

Table 627.52(B)(1)(2) Minimum Ventilation Required in Cubic Feet per Minute (cfm) for Each of the Total Number of Electric Vehicles That Can Be Charged at One Time

Branch-Circuit Ampere Rating	Branch-Circuit Voltage								
	Single-Phase					3-Phase			
	DC	240 V or			208 V or	480 V or		600 V or	
	≥ 50 V	120 V	208 V	120/240 V	208Y/120 V	240 V	480Y/277 V	600Y/347 V	
15	15.4	37	64	74	—	—	—	—	—
20	20.4	49	85	99	148	171	342	—	427
30	30.8	74	128	148	222	256	512	—	641
40	41.3	99	171	197	296	342	683	—	854
50	51.3	123	214	246	370	427	854	—	1066
60	61.7	148	256	296	444	512	1025	—	1281
100	102.5	246	427	493	740	854	1708	—	2135
150	—	—	—	—	1110	1281	2562	—	3203
200	—	—	—	—	1480	1708	3416	—	4270
250	—	—	—	—	1850	2135	4270	—	5338
300	—	—	—	—	2221	2562	5125	—	6406
350	—	—	—	—	2591	2989	5979	—	7473
400	—	—	—	—	2961	3416	6832	—	8541

(2) Other Values.

For supply voltages and currents other than specified in Table 627.52(B)(1)(1) or Table 627.52(B)(1)(2), the minimum ventilation requirements shall be calculated by means of Equation 627.52(B)(2)a or Equation 627.52(B)(2)b for single-phase ac or dc or Equation 627.52(B)(2)c or Equation 627.52(B)(2)d for 3-phase ac.

$$\text{ventilation single-phase ac or dc in cubic meters per minute} \left(\frac{\text{m}^3}{\text{min}} \right) = \frac{(\text{volts})(\text{amperes})}{1718} \quad [627.52(B)(2)a]$$

$$\text{ventilation single-phase ac or dc in cubic feet per minute (cfm)} = \frac{(\text{volts})(\text{amperes})}{48.7} \quad [627.52(B)(2)b]$$

$$\text{ventilation 3-phase ac or dc in cubic meters per minute} \left(\frac{\text{m}^3}{\text{min}} \right) = \frac{(1.732)(\text{volts})(\text{amperes})}{1718} \quad [627.52(B)(2)c]$$

$$\text{ventilation 3-phase ac or dc in cubic feet per minute (cfm)} = \frac{(1.732)(\text{volts})(\text{amperes})}{48.7} \quad [627.52(B)(2)d]$$

(3) Engineered Systems.

For equipment ventilation systems designed by persons qualified to perform such calculations as integral parts of total ventilation systems for buildings, minimum ventilation requirements shall be permitted to be determined in accordance with calculations specified in engineering studies.

(4) Supply Circuits.

Supply circuits to mechanical ventilation equipment shall be electrically interlocked with the equipment and remain energized during the entire electric vehicle charging cycle. Equipment receptacles rated at 125 volts, single phase, 15 and 20 amperes shall be switched, with mechanical ventilation systems electrically interlocked through the switch supply power to the receptacles. Equipment supplied from less than 50 volts dc shall be switched with mechanical ventilation systems electrically interlocked through the switch supply power to the equipment.

627.54 Ground-Fault Circuit-Interrupter Protection for Personnel.

All receptacles installed for the connection of ESVSE shall have GFCI protection for personnel.

627.56 Receptacle Enclosures.

All receptacles installed in wet locations for electric vehicle charging shall have enclosures that are weatherproof with attachment plug caps inserted or removed. Outlet box hoods installed for this purpose shall be listed and be identified as extra duty. Other listed products, enclosures, or assemblies providing weatherproof protection that do not use outlet box hoods shall not be required to be marked extra duty.

Part IV. Wireless Power Transfer Equipment

627.101 Grounding.

Primary pad base plates shall be constructed of nonferrous metal and be connected to circuit equipment grounding conductors unless the listed WPTE employs double-insulation systems. Base plates shall be sized to match the size of the primary pad enclosures.

627.102 Installation.

(A) General.

Control pads, if included in WPTE configuration, shall comply with 627.102(B). The primary pad shall comply with 627.102(C).

(B) Control Box.

Control box enclosures shall be suitable for the environment and be mounted at a height not less than 450 mm (18 in.) above the floor level for indoor locations or 600 mm (24 in.) above grade level for outdoor locations in one of the following forms:

- (1) Pedestals
- (2) Walls or poles
- (3) Buildings or structures
- (4) Raised concrete pads

(C) Primary Pads.

Primary pads shall be installed secured to the surface or embedded in the surface of the floor with their tops flush with or below the surface in accordance with the manufacturer's instructions and the following:

- (1) If located in an area requiring snow removal, primary pads shall not be located on or above the surface.
Exception: Where installed on private property where snow removal is done manually, primary pads shall be permitted to be installed on or above the surface.
- (2) Primary pad enclosures shall be suitable for the environment and, if located in an area subject to severe climatic conditions (e.g., flooding), suitably rated for those conditions.

(D) Protection of Cords and Cables to Primary Pads.

Output cables to primary pads shall be secured in place over its entire length to restrict movement and to prevent strain at the connection points. If installed in conditions where drive-over could occur, cables shall be provided with supplemental protection.

Where control boxes are not provided, cords or cables supplying power to primary pads shall be secured in place to restrict movement and to prevent strain at the connection points. Where subject to vehicular traffic, supplemental protection shall be provided.

(E) Other Wiring Systems.

Other wiring systems and fittings specifically listed for use on WPTE shall be permitted.

Statement of Problem and Substantiation for Public Comment

Task Group for CMP 12 was convened and we propose that this Article be accepted and numbered as Article 624 to be adjacent to the similar Article 625.

Related Item

- FR 9039

Submitter Information Verification

Submitter Full Name: Richard Shawbell

Organization: Florida East Coast Electrical

Street Address:

City:

State:

Zip:

Submittal Date: Tue Jul 23 10:44:40 EDT 2024

Committee: NEC-P12



Article 627 Electric Self-Propelled Vehicle Power Transfer Systems (ESVSEs)

Part I. General

627.1 Scope.

This article covers the electrical conductors and equipment connecting an electric self-propelled vehicle (ESV) to premises wiring for the purposes of charging, power export, or bidirectional current flow.

627.2 Listing Requirements.

Electric self-propelled vehicle supply equipment (ESVSE), including power supply cords for the purposes of charging, power export, or bidirectional current flow, shall be listed.

627.4 Voltages.

Unless other voltages are specified, the nominal ac system voltages of 120, 120/240, 208Y/120, 240, 480Y/277, 480, 600Y/347, 600, or 1000 volts or dc system input voltages of up to 1000 volts shall be used to supply equipment covered by Article 627.

Output voltages to the ESV are not specified.

Part II. Equipment Construction

627.17 Cords and Cables.

(A) Power-Supply Cords.

Cables for cord-connected ESVSE shall comply with all of the following:

- (1) Be any of the types specified in 627.17(B)(1) or hard service cord, junior hard service cord, or portable power cable types in accordance with Table 400.4. Hard service cord, junior hard service cord, or portable power cable types shall be listed, as applicable, for exposure to oil and damp and wet locations.
- (2) Have an ampacity as specified in Table 400.5(A)(1) or, for 8 AWG and larger, in the 60°C (140°F) columns of Table 400.5(A)(2)
- (3) Have an overall length as specified in either of the following:
 - a. When the interrupting device of the personnel protection system specified in 627.22 is located within the enclosure of the supply equipment or charging system, the power-supply cord is not more than indicated in either of the following:
 - i. For portable equipment in accordance with 627.44(A), not more than 300 mm (12 in.) long
 - ii. For fastened-in-place equipment in accordance with 627.44(B)627.44(B), not more than 1.8 m (6 ft) long, with equipment installed at a height that prevents the power-supply cord from contacting the floor when it is connected to the proper receptacle
 - b. When the interrupting device of the personnel protection system specified in 627.22 is located at the attachment plug, or within the first 300 mm (12 in.) of the power-supply cord, not more than 4.6 m (15 ft) long

(B) Output Cables to ESV.

Output cables to ESVs shall be either of the following

- (1) Listed Types EV, EVJ, EVE, EVJE, EVT, or EVJT flexible cables as specified in Table 400.4
- (2) Integral parts of listed ESVSE

(C) Overall Cord and Cable Length.

Overall usable length shall not exceed 7.5 m (25 ft) unless equipped with a cable management system that is part of the listed ESVSE.

(1) Portable Equipment.

For portable ESVSE, cord-exposed usable length shall be measured from the face of attachment plugs to the face of ESV connectors.

(2) Fastened-in-Place.

(a) Where ESVSE is fastened-in-place, the usable length of output cables to ESVs shall be measured from the cable exits of the ESVSE to the face of ESV connectors.

(b) Where wireless power transfer equipment (WPTE) is fastened-in-place, the output cables to the primary pads shall be measured from the cable exits of the control boxes to the cable inlets at the primary pads.

(D) Interconnecting Cabling Systems.

Other cabling systems that are integral parts of listed supply equipment and are intended to interconnect pieces of equipment within ESVSE systems using approved installation methods shall be permitted.

627.22 Personnel Protection Systems.

ESVSE shall have a listed system of protection against electric shock of personnel and comply with the following:

- (1) Where cord-and-plug-connected equipment is used, the interrupting device of a listed personnel protection system shall be provided according to 627.17(A).
- (2) A personnel protection system shall not be required for power transfer equipment that supplies less than 60 volts dc.

Part III. Installation

627.40 ESVSE Branch Circuits.

Each outlet installed for the purpose of supplying ESVSE greater than 16 amperes, or 120 volts, shall be supplied by an individual branch circuit.

Exception: Branch circuits shall be permitted to feed multiple ESVSE as permitted by 627.42(A) or 627.42(B).

627.41 Overcurrent Protection.

(A) General.

Overcurrent protection for feeders and branch circuits supplying ESVSE and WPTE, including bidirectional equipment, shall be sized for continuous duty and have a current rating of not less than 125 percent of the maximum load of the equipment.

(B) Noncontinuous Loads.

Where noncontinuous loads are supplied from the same feeder, overcurrent devices shall have current ratings of not less than the sum of the noncontinuous loads plus 125 percent of the continuous loads.

627.42 Rating.

ESVSE shall have sufficient rating to supply the load served. Charging loads shall be considered continuous loads for the purposes of this article. Service and feeders shall be sized in accordance with the product ratings, unless the overall rating of the installation can be limited through controls as permitted by 627.42(A) or 627.42(B).

(A) Energy Management System (EMS).

Where energy management systems (EMSs) in accordance with 130.30 provide load management of ESVSE, the maximum equipment load on service and feeders shall be the maximum load permitted by the EMS. EMSs shall be permitted to be integral to one piece of equipment or integral to listed systems consisting of more than one piece of equipment. When one or more pieces of equipment are provided with integral load management control, systems shall be marked to indicate such control is provided.

(B) Supply Equipment with Adjustable Settings.

Supply equipment with restricted access to an ampere adjusting means complying with 130.30(C) shall be permitted. If adjustments have an impact on the rating label, such changes shall comply with manufacturer's instructions, with the adjusted rating appearing on the rating label with sufficient durability to withstand the environment involved. Such supply equipment shall be permitted to have ampere ratings that are equal to the adjusted current setting.

627.43 Disconnecting Means.

Supply equipment rated more than 60 amperes or more than 150 volts to ground shall be provided with a disconnecting means installed in a readily accessible location. If the disconnecting means is installed remote from the equipment, a plaque shall be installed on the equipment denoting the location of the disconnecting means. The disconnecting means shall be lockable open in accordance with 110.25.

627.44 Equipment Connection.

ESVSE and WPTE shall be connected to the premises wiring system in accordance with one of the methods in 627.44(A) through 627.44(C).

(A) Portable Equipment.

Portable equipment shall be connected to the premises wiring system by one or more of the following methods:

- (1) A nonlocking, 2-pole, 3-wire grounding-type receptacle outlet rated at 125 volts, single phase, 15 or 20 amperes
- (2) A nonlocking, 2-pole, 3-wire grounding-type receptacle outlet rated at 250 volts, single phase, 15 or 20 amperes
- (3) A nonlocking, 2-pole, 3-wire or 3-pole, 4-wire grounding-type receptacle outlet rated at 250 volts, single phase, 30 or 50 amperes, or at 125/250 volts, single-phase, 30, 50, or 60 amperes
- (4) A nonlocking, 2-pole, 3-wire grounding-type receptacle outlet rated at 60 volts dc maximum, 15 or 20 amperes

(B) Fastened-in-Place Equipment.

Equipment that is fastened-in-place shall be connected to the premises wiring system by one of the following methods:

- (1) A nonlocking, 2-pole, 3-wire grounding-type receptacle outlet rated 125 volts or 250 volts, single phase, up to 50 amperes
- (2) A nonlocking, 3-pole, 4-wire grounding-type receptacle outlet rated 250 volts, three phase, up to 50 amperes
- (3) A nonlocking, 3-pole, 4-wire grounding-type receptacle outlet rated 125/250 volts, single phase, 30, 50, or 60 amperes
- (4) A nonlocking, 2-pole, 3-wire grounding-type receptacle outlet rated 60 volts dc maximum, 15 or 20 amperes

(C) Fixed-in-Place Equipment.

All other ESVSE and WPTE shall be permanently wired and fixed-in-place to supporting surfaces.

627.46 Loss of Primary Source.

Means shall be provided such that energy cannot be backfed through the ESV and supply equipment to the premises wiring system upon loss of voltage from the utility or other electrical systems unless permitted by 627.48.

627.47 Multiple Feeder or Branch Circuits.

Where equipment is identified for the application, more than one feeder or branch circuit shall be permitted to supply equipment.

627.48 Interactive Equipment.

ESVSE or WPTE that incorporates power export functions and are part of interactive systems that serve as optional standby systems, electric power production sources, or bidirectional power feeds shall be listed and marked as suitable for that purpose. When ESVSE or WPTE are used as optional standby systems, the requirements of Article 702, Parts I and II, shall apply; when ESVSE or WPTE are used as electric power production sources, the requirements of Article 705, Parts I and II, shall apply. Electric vehicle power export equipment (EVPE) that provide receptacle outlets as points of power export shall comply with 627.60.

627.49 Island Mode.

Electric self-propelled vehicle power export equipment (ESVPE) and bidirectional ESVSE that incorporate power export functions shall be permitted to be part of interconnected power systems operating in island mode.

627.50 Location.

ESVSE shall be located for direct electrical coupling of ESV connectors (conductive or inductive) to ESVs. Unless specifically listed and marked for the location, the coupling means of ESVs shall be stored or located at a height of not less than 450 mm (18 in.) above the floor level for indoor locations or 600 mm (24 in.) above the grade level for outdoor locations.

This requirement shall not apply to portable ESVSE constructed in accordance with 627.44(A).

627.52 Ventilation.

Ventilation for charging ESVs in indoor enclosed spaces shall be determined by 627.52(A) or 627.52(B).

(A) Ventilation Not Required.

Where ESV storage batteries are used or where equipment is listed for charging ESVs indoors without ventilation, mechanical ventilation shall not be required.

(B) Ventilation Required.

Where equipment is listed for charging ESVs that require ventilation for indoor charging, mechanical ventilation shall be provided. The ventilation shall include both supply and exhaust equipment and shall be permanently installed and located to intake from, and vent directly to, the outdoors. Positive-pressure ventilation systems shall be permitted only in vehicle charging buildings or areas that have been specifically designed and approved for that application. Mechanical ventilation requirements shall be determined by one of the methods specified in 627.52(B)(1) through 627.52(B)(4).

Informational Note: An example of mechanical ventilation would be a fan.

(1) Table Values.

For supply voltages and currents specified in Table 627.52(B)(1)(1) or Table 627.52(B)(1)(2), the minimum ventilation requirements shall be as specified in Table 627.52(B)(1)(1) or Table 627.52(B)(1)(2) for each of the total number of electric vehicles that can be charged at one time.

Table 627.52(B)(1)(1) Minimum Ventilation Required in Cubic Meters per Minute (m³/min) for Each of the Total Number of ESVs That Can Be Charged at One Time

Branch-Circuit Ampere Rating	Branch-Circuit Voltage								
	Single-Phase					3-Phase			
	DC ≥ 50 V	120 V	208 V	240 V or 120/240 V	208 V or 208Y/120 V	240 V	480 V or 480Y/277 V	600 V or 600Y/347 V	
15	0.5	1.1	1.8	2.1	—	—	—	—	
20	0.6	1.4	2.4	2.8	4.2	4.8	9.7	12	
30	0.9	2.1	3.6	4.2	6.3	7.2	15	18	
40	1.2	2.8	4.8	5.6	8.4	9.7	19	24	
50	1.5	3.5	6.1	7	10	12	24	30	
60	1.8	4.2	7.3	8.4	13	15	29	36	
100	2.9	7	12	14	21	24	48	60	
150	—	—	—	—	31	36	73	91	
200	—	—	—	—	42	48	97	120	
250	—	—	—	—	52	60	120	150	
300	—	—	—	—	63	73	145	180	
350	—	—	—	—	73	85	170	210	
400	—	—	—	—	84	97	195	240	

Table 627.52(B)(1)(2) Minimum Ventilation Required in Cubic Feet per Minute (cfm) for Each of the Total Number of Electric Vehicles That Can Be Charged at One Time

Branch-Circuit Ampere Rating	Branch-Circuit Voltage								
	Single-Phase					3-Phase			
	DC ≥ 50 V	120 V	208 V	240 V or 120/240 V	208 V or 208Y/120 V	240 V	480 V or 480Y/277 V	600 V or 600Y/347 V	
15	15.4	37	64	74	—	—	—	—	
20	20.4	49	85	99	148	171	342	427	
30	30.8	74	128	148	222	256	512	641	
40	41.3	99	171	197	296	342	683	854	
50	51.3	123	214	246	370	427	854	1066	
60	61.7	148	256	296	444	512	1025	1281	
100	102.5	246	427	493	740	854	1708	2135	
150	—	—	—	—	1110	1281	2562	3203	
200	—	—	—	—	1480	1708	3416	4270	
250	—	—	—	—	1850	2135	4270	5338	
300	—	—	—	—	2221	2562	5125	6406	
350	—	—	—	—	2591	2989	5979	7473	
400	—	—	—	—	2961	3416	6832	8541	

(2) Other Values.

For supply voltages and currents other than specified in Table 627.52(B)(1)(1) or Table 627.52(B)(1)(2), the minimum ventilation requirements shall be calculated by means of Equation 627.52(B)(2)a or Equation 627.52(B)(2)b for single-phase ac or dc or Equation 627.52(B)(2)c or Equation 627.52(B)(2)d for 3-phase ac.

$$\text{ventilation single-phase ac or dc in cubic meters per minute} \left(\frac{\text{m}^3}{\text{min}} \right) = \frac{(\text{volts})(\text{amperes})}{1718} \quad [627.52(B)(2)a]$$

$$\text{ventilation single-phase ac or dc in cubic feet per minute (cfm)} = \frac{(\text{volts})(\text{amperes})}{48.7} \quad [627.52(B)(2)b]$$

$$\text{ventilation 3-phase ac or dc in cubic meters per minute} \left(\frac{\text{m}^3}{\text{min}} \right) = \frac{(1.732)(\text{volts})(\text{amperes})}{1718} \quad [627.52(B)(2)c]$$

$$\text{ventilation 3-phase ac or dc in cubic feet per minute (cfm)} = \frac{(1.732)(\text{volts})(\text{amperes})}{48.7} \quad [627.52(B)(2)d]$$

(3) Engineered Systems.

For equipment ventilation systems designed by persons qualified to perform such calculations as integral parts of total ventilation systems for buildings, minimum ventilation requirements shall be permitted to be determined in accordance with calculations specified in engineering studies.

(4) Supply Circuits.

Supply circuits to mechanical ventilation equipment shall be electrically interlocked with the equipment and remain energized during the entire electric vehicle charging cycle. Equipment receptacles rated at 125 volts, single phase, 15 and 20 amperes shall be switched, with mechanical ventilation systems electrically interlocked through the switch supply power to the receptacles. Equipment supplied from less than 50 volts dc shall be switched with mechanical ventilation systems electrically interlocked through the switch supply power to the equipment.

627.54 Ground-Fault Circuit-Interrupter Protection for Personnel.

All receptacles installed for the connection of ES/SVSE shall have GFCI protection for personnel.

627.56 Receptacle Enclosures.

All receptacles installed in wet locations for electric vehicle charging shall have enclosures that are weatherproof with attachment plug caps inserted or removed. Outlet box hoods installed for this purpose shall be listed and be identified as extra duty. Other listed products, enclosures, or assemblies providing weatherproof protection that do not use outlet box hoods shall not be required to be marked extra duty.

Part IV. Wireless Power Transfer Equipment

627.101 Grounding.

Primary pad base plates shall be constructed of nonferrous metal and be connected to circuit equipment grounding conductors unless the listed WPTE employs double-insulation systems. Base plates shall be sized to match the size of the primary pad enclosures.

627.102 Installation.

(A) General.

Control pads, if included in WPTE configuration, shall comply with 627.102(B). The primary pad shall comply with 627.102(C).

(B) Control Box.

Control box enclosures shall be suitable for the environment and be mounted at a height not less than 450 mm (18 in.) above the floor level for indoor locations or 600 mm (24 in.) above grade level for outdoor locations in one of the following forms:

- (1) Pedestals
- (2) Walls or poles
- (3) Buildings or structures
- (4) Raised concrete pads

(C) Primary Pads.

Primary pads shall be installed secured to the surface or embedded in the surface of the floor with their tops flush with or below the surface in accordance with the manufacturer's instructions and the following:

- (1) If located in an area requiring snow removal, primary pads shall not be located on or above the surface.

Exception: Where installed on private property where snow removal is done manually, primary pads shall be permitted to be installed on or above the surface.

- (2) Primary pad enclosures shall be suitable for the environment and, if located in an area subject to severe climatic conditions (e.g., flooding), suitably rated for those conditions.

(D) Protection of Cords and Cables to Primary Pads.

Output cables to primary pads shall be secured in place over its entire length to restrict movement and to prevent strain at the connection points. If installed in conditions where drive-over could occur, cables shall be provided with supplemental protection.

Where control boxes are not provided, cords or cables supplying power to primary pads shall be secured in place to restrict movement and to prevent strain at the connection points. Where subject to vehicular traffic, supplemental protection shall be provided.

(E) Other Wiring Systems.

Other wiring systems and fittings specifically listed for use on WPTE shall be permitted.

Statement of Problem and Substantiation for Public Comment

Related Item

- FR-7788

Submitter Information Verification

Submitter Full Name: LATANE BRACKETT
Organization: Jackson State University
Street Address:
City:
State:
Zip:
Submittal Date: Wed Aug 28 17:30:28 EDT 2024
Committee: NEC-P12



Public Comment No. 809-NFPA 70-2024 [Article 627]

~~Article 627~~ Electric Self-Propelled Vehicle Power Transfer Systems (ESVSEs)

~~Part I~~— General

~~627.1~~ Scope:

This article covers the electrical conductors and equipment connecting an electric self-propelled vehicle (ESV) to premises wiring for the purposes of charging, power export, or bidirectional current flow.

~~627.2~~ Listing Requirements:

Electric self-propelled vehicle supply equipment (ESVSE), including power supply cords for the purposes of charging, power export, or bidirectional current flow, shall be listed.

~~627.4~~ Voltages:

Unless other voltages are specified, the nominal ac system voltages of 120, 120/240, 208Y/120, 240, 480Y/277, 480, 600Y/347, 600, or 1000 volts or dc system input voltages of up to 1000 volts shall be used to supply equipment covered by Article ~~627~~ .

Output voltages to the ESV are not specified.

~~Part II~~— Equipment Construction

~~627.17~~ Cords and Cables:

~~(A)~~ Power Supply Cords:

Cables for cord-connected ESVSE shall comply with all of the following:

- (1) ~~Be any of the types specified in 627.17(B)(1) or hard service cord, junior hard service cord, or portable power cable types in accordance with Table 400.4 . Hard service cord, junior hard service cord, or portable power cable types shall be listed, as applicable, for exposure to oil and damp and wet locations.~~
- (2) ~~Have an ampacity as specified in Table 400.5(A)(1) or, for 8 AWG and larger, in the 60°C (140°F) columns of Table 400.5(A)(2)~~
- (3) ~~Have an overall length as specified in either of the following:~~
 - (4) ~~When the interrupting device of the personnel protection system specified in 627.22 is located within the enclosure of the supply equipment or charging system, the power supply cord is not more than indicated in either of the following:~~
 - (5) ~~For portable equipment in accordance with 627.44(A) , not more than 300 mm (12 in.) long~~
 - (6) ~~For fastened-in-place equipment in accordance with 627.44(B) 627.44(D), not more than 1.8 m (6 ft) long, with equipment installed at a height that prevents the power supply cord from contacting the floor when it is connected to the proper receptacle~~
 - (7) ~~When the interrupting device of the personnel protection system specified in 627.22 is located at the attachment plug, or within the first 300 mm (12 in.) of the power supply cord, not more than 4.6 m (15 ft) long~~

~~(B)~~ Output Cables to ESV:

Output cables to ESVs shall be either of the following

- (1) ~~Listed Types EV, EVJ, EVE, EVJE, EVT, or EVJT flexible cables as specified in Table 400.4~~
- (2) ~~Integral parts of listed ESVSE~~

~~(C)~~ Overall Cord and Cable Length:

Overall usable length shall not exceed 7.5 m (25 ft) unless equipped with a cable management system that is part of the listed ESVSE.

~~(1)~~ Portable Equipment:

For portable ESVSE, cord-exposed usable length shall be measured from the face of attachment plugs to the face of ESV connectors:

~~(2)~~ Fastened-in-Place:

(a) ~~Where ESVSE is fastened-in-place, the usable length of output cables to ESVs shall be measured from the cable exits of the ESVSE to the face of ESV connectors.~~

(b) ~~Where wireless power transfer equipment (WPTE) is fastened-in-place, the output cables to the primary pads shall be measured from the cable exits of the control boxes to the cable inlets at the primary pads.~~

~~(D)~~ Interconnecting Cabling Systems:

Other cabling systems that are integral parts of listed supply equipment and are intended to interconnect pieces of equipment within ESVSE systems using approved installation methods shall be permitted:

~~627.22~~ Personnel Protection Systems:

ESVSE shall have a listed system of protection against electric shock of personnel and comply with the following:

- (1) ~~Where cord-and-plug-connected equipment is used, the interrupting device of a listed personnel protection system shall be provided according to 627.17(A) .~~
- (2) ~~A personnel protection system shall not be required for power transfer equipment that supplies less than 60 volts dc.~~

~~Part III~~— Installation

627.40- ESVSE Branch Circuits:

Each outlet installed for the purpose of supplying ESVSE greater than 16 amperes, or 120 volts, shall be supplied by an individual branch circuit.

Exception: Branch circuits shall be permitted to feed multiple ESVSE as permitted by 627.42(A) or 627.42(B) :

627.41- Overcurrent Protection:

(A)- General:

Overcurrent protection for feeders and branch circuits supplying ESVSE and WPTE, including bidirectional equipment, shall be sized for continuous duty and have a current rating of not less than 125 percent of the maximum load of the equipment.

(B)- Noncontinuous Loads:

Where noncontinuous loads are supplied from the same feeder, overcurrent devices shall have current ratings of not less than the sum of the noncontinuous loads plus 125 percent of the continuous loads.

627.42- Rating:

ESVSE shall have sufficient rating to supply the load served. Charging loads shall be considered continuous loads for the purposes of this article. Service and feeders shall be sized in accordance with the product ratings, unless the overall rating of the installation can be limited through controls as permitted by 627.42(A) or 627.42(B) :

(A)- Energy Management System (EMS):

Where energy management systems (EMSs) in accordance with 130.30 provide load management of ESVSE, the maximum equipment load on service and feeders shall be the maximum load permitted by the EMS. EMSs shall be permitted to be integral to one piece of equipment or integral to listed systems consisting of more than one piece of equipment. When one or more pieces of equipment are provided with integral load management control, systems shall be marked to indicate such control is provided.

(B)- Supply Equipment with Adjustable Settings:

Supply equipment with restricted access to an ampere adjusting means complying with 130.30(C) shall be permitted. If adjustments have an impact on the rating label, such changes shall comply with manufacturer's instructions, with the adjusted rating appearing on the rating label with sufficient durability to withstand the environment involved. Such supply equipment shall be permitted to have ampere ratings that are equal to the adjusted current setting.

627.43- Disconnecting Means:

Supply equipment rated more than 60 amperes or more than 150 volts to ground shall be provided with a disconnecting means installed in a readily accessible location. If the disconnecting means is installed remote from the equipment, a plaque shall be installed on the equipment denoting the location of the disconnecting means. The disconnecting means shall be lockable open in accordance with 110.25 :

627.44- Equipment Connection:

ESVSE and WPTE shall be connected to the premises wiring system in accordance with one of the methods in 627.44(A) through 627.44(C) :

(A)- Portable Equipment:

Portable equipment shall be connected to the premises wiring system by one or more of the following methods:

- (1) A nonlocking, 2-pole, 3-wire grounding-type receptacle outlet rated at 125 volts, single phase, 15 or 20 amperes
- (2) A nonlocking, 2-pole, 3-wire grounding-type receptacle outlet rated at 250 volts, single phase, 15 or 20 amperes
- (3) A nonlocking, 2-pole, 3-wire or 3-pole, 4-wire grounding-type receptacle outlet rated at 250 volts, single phase, 30 or 50 amperes, or at 125/250 volts, single phase, 30, 50, or 60 amperes
- (4) A nonlocking, 2-pole, 3-wire grounding-type receptacle outlet rated at 60 volts dc maximum, 15 or 20 amperes

(B)- Fastened-in-Place Equipment:

Equipment that is fastened-in-place shall be connected to the premises wiring system by one of the following methods:

- (1) A nonlocking, 2-pole, 3-wire grounding-type receptacle outlet rated 125 volts or 250 volts, single phase, up to 50 amperes
- (2) A nonlocking, 3-pole, 4-wire grounding-type receptacle outlet rated 250 volts, three phase, up to 50 amperes
- (3) A nonlocking, 3-pole, 4-wire grounding-type receptacle outlet rated 125/250 volts, single phase, 30, 50, or 60 amperes
- (4) A nonlocking, 2-pole, 3-wire grounding-type receptacle outlet rated 60 volts dc maximum, 15 or 20 amperes

(C)- Fixed-in-Place Equipment:

All other ESVSE and WPTE shall be permanently wired and fixed-in-place to supporting surfaces:

627.46- Loss of Primary Source:

Means shall be provided such that energy cannot be backed through the ESV and supply equipment to the premises wiring system upon loss of voltage from the utility or other electrical systems unless permitted by 627.48 :

627.47- Multiple Feeder or Branch Circuits:

Where equipment is identified for the application, more than one feeder or branch circuit shall be permitted to supply equipment.

627.48- Interactive Equipment:

ESVSE or WPTE that incorporates power export functions and are part of interactive systems that serve as optional standby systems, electric power production sources, or bidirectional power feeds shall be listed and marked as suitable for that purpose. When ESVSE or WPTE are used as optional standby systems, the requirements of Article 702 ,Parts I and II, shall apply; when ESVSE or WPTE are used as electric power production sources, the requirements of Article 705 ,Parts I and II, shall apply. Electric vehicle power export equipment (EVPE) that provide receptacle outlets as points of power export shall comply with 627.60.

627.49- Island Mode:

Electric self-propelled vehicle power export equipment (ESVPE) and bidirectional ESVSE that incorporate power export functions shall be permitted to be part of interconnected power systems operating in island mode:

627.50- Location:

ESVSE shall be located for direct electrical coupling of ESV connectors (conductive or inductive) to ESVs. Unless specifically listed and marked for the location, the coupling means of ESVs shall be stored or located at a height of not less than 450 mm (18 in.) above the floor level for indoor locations or 600 mm (24 in.) above the grade level for outdoor locations:

This requirement shall not apply to portable ESVSE constructed in accordance with 627.44(A) :

627.52- Ventilation:

Ventilation for charging ESVs in indoor enclosed spaces shall be determined by 627.52(A) or 627.52(B) :

(A)– Ventilation Not Required.

Where ESV storage batteries are used or where equipment is listed for charging ESVs indoors without ventilation, mechanical ventilation shall not be required.

(B)– Ventilation Required.

Where equipment is listed for charging ESVs that require ventilation for indoor charging, mechanical ventilation shall be provided. The ventilation shall include both supply and exhaust equipment and shall be permanently installed and located to intake from, and vent directly to, the outdoors. Positive-pressure ventilation systems shall be permitted only in vehicle charging buildings or areas that have been specifically designed and approved for that application. Mechanical ventilation requirements shall be determined by one of the methods specified in 627.52(B)(1) through 627.52(B)(4).

Informational Note: An example of mechanical ventilation would be a fan.

(1)– Table Values.

For supply voltages and currents specified in Table 627.52(B)(1)(1) or Table 627.52(B)(1)(2), the minimum ventilation requirements shall be as specified in Table 627.52(B)(1)(1) or Table 627.52(B)(1)(2) for each of the total number of electric vehicles that can be charged at one time.

Table 627.52(B)(1)(1) Minimum Ventilation Required in Cubic Meters per Minute (m^3/min) for Each of the Total Number of ESVs That Can Be Charged at One Time
Branch-Circuit Ampere Rating Branch-Circuit Voltage Single-Phase - 3-Phase DC

≥ 50 V 120 V 208 V 240 V or

120/240 V - 208 V or

208Y/120 V 240 V 480 V or

480Y/277 V 600 V or

600Y/347 V 15 0.5 1.1 1.8 2.4 - - - - -
20 0.6 1.4 2.4 2.8 - 4.2 4.8 9.7 12 30 0.9 2.1 3.6 4.2 - 6.3 7.2 15 18 40 1.2 2.8 4.8 5.6 - 8.4 9.7 19 24 50 1.5 3.5 6.1 7 - 10 12 24 30 60 1.8 4.2 7.3 8.4 - 13 15 29 36 -
- - - - - 34 36 73 91 200 - - - - - 42 48 97 120 250 - - - - - 52 60 120 150 300 - - - - - 63 73 145 180 350 - - - - - 73 85 170 210 400
- - - - - 84 97 195 240

Table 627.52(B)(1)(2) Minimum Ventilation Required in Cubic Feet per Minute (cfm) for Each of the Total Number of Electric Vehicles That Can Be Charged at One Time
Branch-Circuit Ampere Rating Branch-Circuit Voltage Single-Phase - 3-Phase DC

≥ 50 V 120 V 208 V 240 V or

120/240 V - 208 V or

208Y/120 V 240 V 480 V or

480Y/277 V 600 V or

600Y/347 V 15 15.4 37 64 74 - - - - -
20 20.4 49 85 99 - 148 174 342 427 30 30.8 74 128 148 - 222 256 512 641 40 41.3 99 171 197 - 296 342 683 854 50 51.3 123 214 246 - 370 427 854 1066 60 61 -
- - - - - 1110 1291 2562 3203 200 - - - - - 1480 1708 3416 4270 250 - - - - - 1850 2135 4270 5338 300 - - - - - 2224 2562 5125 6406 350
- - - - - 2591 2989 5979 7473 400 - - - - - 2961 3416 6832 8541

(2)– Other Values.

For supply voltages and currents other than specified in Table 627.52(B)(1)(1) or Table 627.52(B)(1)(2), the minimum ventilation requirements shall be calculated by means of Equation 627.52(B)(2)a or Equation 627.52(B)(2)b for single-phase ac or dc or Equation 627.52(B)(2)c or Equation 627.52(B)(2)d for 3-phase ac.

$$\text{ventilation single-phase ac or dc in cubic meters per minute} \left(\frac{m^3}{\text{min}} \right) = \frac{(\text{volts})(\text{amperes})}{1718} \quad [627.52(B)(2)a]$$

$$\text{ventilation single-phase ac or dc in cubic feet per minute (cfm)} = \frac{(\text{volts})(\text{amperes})}{48.7} \quad [627.52(B)(2)b]$$

$$\text{ventilation 3-phase ac or dc in cubic meters per minute} \left(\frac{m^3}{\text{min}} \right) = \frac{(1.732)(\text{volts})(\text{amperes})}{1718} \quad [627.52(B)(2)c]$$

$$\text{ventilation 3-phase ac or dc in cubic feet per minute (cfm)} = \frac{(1.732)(\text{volts})(\text{amperes})}{48.7} \quad [627.52(B)(2)d]$$

(3)– Engineered Systems.

For equipment ventilation systems designed by persons qualified to perform such calculations as integral parts of total ventilation systems for buildings, minimum ventilation requirements shall be permitted to be determined in accordance with calculations specified in engineering studies.

(4)– Supply Circuits.

Supply circuits to mechanical ventilation equipment shall be electrically interlocked with the equipment and remain energized during the entire electric vehicle charging cycle. Equipment receptacles rated at 125 volts, single phase, 15 and 20 amperes shall be switched, with mechanical ventilation systems electrically interlocked through the switch supply power to the receptacles. Equipment supplied from less than 50 volts dc shall be switched with mechanical ventilation systems electrically interlocked through the switch supply power to the equipment.

627.54– Ground-Fault Circuit-Interrupter Protection for Personnel.

All receptacles installed for the connection of ESVSE shall have GFCI protection for personnel.

627.56– Receptacle Enclosures.

All receptacles installed in wet locations for electric vehicle charging shall have enclosures that are weatherproof with attachment plug caps inserted or removed. Outlet box hoods installed for this purpose shall be listed and be identified as extra duty. Other listed products, enclosures, or assemblies providing weatherproof protection that do not use outlet box hoods shall not be required to be marked extra duty.

Part IV– Wireless Power Transfer Equipment

~~627.101~~ Grounding:

~~Primary pad base plates shall be constructed of nonferrous metal and be connected to circuit equipment grounding conductors unless the listed WPTE employs double-insulation systems. Base plates shall be sized to match the size of the primary pad enclosures.~~

~~627.102~~ Installation:

~~(A)~~ General:

~~Control pads, if included in WPTE configuration, shall comply with 627.102(D). The primary pad shall comply with 627.102(C):~~

~~(B)~~ Control Box:

~~Control box enclosures shall be suitable for the environment and be mounted at a height not less than 450 mm (18 in.) above the floor level for indoor locations or 600 mm (24 in.) above grade level for outdoor locations in one of the following forms:~~

- ~~(1) Pedestals~~
- ~~(2) Walls or poles~~
- ~~(3) Buildings or structures~~
- ~~(4) Raised concrete pads~~

~~(C)~~ Primary Pads:

~~Primary pads shall be installed secured to the surface or embedded in the surface of the floor with their tops flush with or below the surface in accordance with the manufacturer's instructions and the following:~~

- ~~(1) If located in an area requiring snow removal, primary pads shall not be located on or above the surface.
Exception: Where installed on private property where snow removal is done manually, primary pads shall be permitted to be installed on or above the surface.~~
- ~~(2) Primary pad enclosures shall be suitable for the environment and, if located in an area subject to severe climatic conditions (e.g., flooding), suitably rated for those conditions.~~

~~(D)~~ Protection of Cords and Cables to Primary Pads:

~~Output cables to primary pads shall be secured in place over its entire length to restrict movement and to prevent strain at the connection points. If installed in conditions where drive-over could occur, cables shall be provided with supplemental protection.~~

~~Where control boxes are not provided, cords or cables supplying power to primary pads shall be secured in place to restrict movement and to prevent strain at the connection points. Where subject to vehicular traffic, supplemental protection shall be provided.~~

~~(E)~~ Other Wiring Systems:

~~Other wiring systems and fittings specifically listed for use on WPTE shall be permitted.~~

Statement of Problem and Substantiation for Public Comment

Why are we adding ten pages of code when adding ten words to the scope of Article 625 would solve the problem?

Related Item

- FR 9039

Submitter Information Verification

Submitter Full Name: Ryan Jackson

Organization: Self-employed

Street Address:

City:

State:

Zip:

Submittal Date: Mon Aug 05 15:58:30 EDT 2024

Committee: NEC-P12



Public Comment No. 1198-NFPA 70-2024 [Section No. 627.1]

627.1 Scope.

This article covers the electrical conductors and equipment connecting an electric self-propelled vehicle (ESV) to premises wiring for the purposes of charging, power export, or bidirectional current flow.

[Informational Note No. 1: See NFPA 505-2018, Fire Safety Standard for Powered Industrial Trucks Including Type Designations, Areas of Use, Conversions, Maintenance, and Operations, for information on fire protection of industrial trucks.](#)

[Informational Note No. 2: See UL 2594-2016, Electrical Vehicle Supply Equipment, for information on conductive electric vehicle supply equipment.](#)

[Informational Note No. 3: See UL 2202-2009, Electric Vehicle Charging System Equipment, for information on conductive electric vehicle charging equipment.](#)

[Informational Note No. 4: See UL 2750-2020, Outline of Investigation for Wireless Power Transfer Equipment for Electric Vehicles, for information on wireless power transfer equipment for transferring power to an electric vehicle.](#)

[Informational Note No. 5: See NECA 413-2019, Installing and Maintaining Electric Vehicle Supply Equipment \(EVSE\), for information on the procedures for installing and maintaining AC Level 1, AC Level 2, and fast-charging dc electric vehicle supply equipment \(EVSE\).](#)

Statement of Problem and Substantiation for Public Comment

The purpose of this Public Comment is to revise 627.1 to be consistent with the informational references found in 625.1.

Related Item

- FR9039

Submitter Information Verification

Submitter Full Name: Megan Hayes

Organization: NEMA

Street Address:

City:

State:

Zip:

Submittal Date: Sat Aug 17 00:13:05 EDT 2024

Committee: NEC-P12



627.1 Scope.

This article covers the electrical conductors and equipment connecting an electric self-propelled vehicle (ESV) or other electricity-generating appliances to premises wiring for the purposes of charging, power export, or bidirectional current flow.

Statement of Problem and Substantiation for Public Comment

Merriam-Webster defines a vehicle as “a means of carrying or transporting something.” However, the current language in the National Electric Code (NEC) excludes unpropelled vehicles, such as solar and battery trailers and carts, as well as portable electricity-generating household appliances. This exclusion lacks a scientifically sound rationale. Unpropelled vehicles like carts, trailers, and cord-connected electricity-generating household appliances should be considered within the NEC's scope as Electric Vehicles (EVs). Without a compliant pathway through codes and standards, the market will likely continue to see the rise of “guerrilla” style solar and storage battery products.

These products, thriving in today's dynamic online marketplace, set the pace outside established regulatory frameworks. By clarifying the regulatory grey areas for mobile, grid-interconnected plug-in equipment, we can establish an unambiguous framework that significantly enhances safety in contrast to the the current “guerrilla style” installations. Including all “plug-in” vehicles, portable devices, and equipment within the NEC will allow us to legally support a safe and smart, interconnected future electric grid by fully including all bidirectional Distributed Energy Resources (DERs). This inclusion would enable lower- and moderate-income prosumers to participate in the electricity market, creating valid economic opportunities for these underserved communities.

Additionally, it would incentivize manufacturers to certify their products, thereby improving consumer protection.

Related Item

- Global FR 9093

Submitter Information Verification

Submitter Full Name: Christian Ofenheusle
Organization: EmpowerSource UG
Street Address:
City:
State:
Zip:
Submittal Date: Fri Aug 23 12:10:13 EDT 2024
Committee: NEC-P12



627.1 Scope.

[This article covers the electrical conductors and equipment connecting an electric self-propelled vehicle \(ESV\), or other electricity-generating appliances to premises wiring for the purposes of charging, power export, or bidirectional current flow.](#)

Statement of Problem and Substantiation for Public Comment

Merriam-Webster defines a vehicle as “a means of carrying or transporting something.”

However, the current language in the National Electric Code (NEC) excludes unpropelled vehicles, such as solar and battery trailers and carts, as well as portable electricity-generating household appliances. This exclusion lacks a scientifically sound rationale.

Unpropelled vehicles like carts, trailers, and cord-connected electricity-generating household appliances should be considered within the NEC's scope as Electric Vehicles (EVs). Without a compliant pathway through codes and standards, the market will likely continue to see the rise of “guerrilla” style solar and storage battery products.

These products, thriving in today's dynamic online marketplace, set the pace outside established regulatory frameworks. By clarifying the regulatory grey areas for mobile, grid-interconnected plug-in equipment, we can establish an unambiguous framework that significantly enhances safety in contrast to the the current “guerrilla style” installations.

Including all “plug-in” vehicles, portable devices, and equipment within the NEC will allow us to legally support a safe and smart, interconnected future electric grid by fully including all bidirectional Distributed Energy Resources (DERs). This inclusion would enable lower- and moderate-income prosumers to participate in the electricity market, creating valid economic opportunities for these underserved communities.

Additionally, it would incentivize manufacturers to certify their products, thereby improving consumer protection.

Related Item

- Global FR 9093

Submitter Information Verification

Submitter Full Name: Martin Winterling

Organization: private

Street Address:

City:

State:

Zip:

Submittal Date: Mon Aug 26 03:45:43 EDT 2024

Committee: NEC-P12



Public Comment No. 1661-NFPA 70-2024 [Section No. 627.1]

627.1 Scope.

This article covers the electrical conductors and equipment connecting an electric self-propelled vehicle (ESV) to premises wiring for the purposes of charging, power export, or bidirectional current flow.

Statement of Problem and Substantiation for Public Comment

Merriam-Webster defines a vehicle as “a means of carrying or transporting something.”

However, the current language in the National Electric Code (NEC) excludes unpropelled vehicles, such as solar and battery trailers and carts, as well as portable electricity-generating household appliances. This exclusion lacks a scientifically sound rationale.

Unpropelled vehicles like carts, trailers, and cord-connected electricity-generating household appliances should be considered within the NEC's scope as Electric Vehicles (EVs). Without a compliant pathway through codes and standards, the market will likely continue to see the rise of “guerrilla” style solar and storage battery products.

These products, thriving in today's dynamic online marketplace, set the pace outside established regulatory frameworks. By clarifying the regulatory grey areas for mobile, grid-interconnected plug-in equipment, we can establish an unambiguous framework that significantly enhances safety in contrast to the the current “guerrilla style” installations.

Including all “plug-in” vehicles, portable devices, and equipment within the NEC will allow us to legally support a safe and smart, interconnected future electric grid by fully including all bidirectional Distributed Energy Resources (DERs). This inclusion would enable lower- and moderate-income prosumers to participate in the electricity market, creating valid economic opportunities for these underserved communities.

Additionally, it would incentivize manufacturers to certify their products, thereby improving consumer protection.

Related Item

- Global FR 9093

Submitter Information Verification

Submitter Full Name: Ulrike Seiffert

Organization: Klimabeirat Wendlingen a.N.

Affiliation: Klimabeirat Wendlingen

Street Address:

City:

State:

Zip:

Submittal Date: Mon Aug 26 04:21:45 EDT 2024

Committee: NEC-P12



627.1 Scope.

[This article covers the electrical conductors and equipment connecting an electric self-propelled vehicle \(ESV\), or other electricity-generating appliances to premises wiring for the purposes of charging, power export, or bidirectional current flow.](#)

Statement of Problem and Substantiation for Public Comment

Merriam-Webster defines a vehicle as "a means of carrying or transporting something."

However, the current language in the National Electric Code (NEC) excludes unpropelled vehicles, such as solar and battery trailers and carts, as well as portable electricity-generating household appliances. This exclusion lacks a scientifically sound rationale.

Unpropelled vehicles like carts, trailers, and cord-connected electricity-generating household appliances should be considered within the NEC's scope as Electric Vehicles (EVs). Without a compliant pathway through codes and standards, the market will likely continue to see the rise of "guerrilla" style solar and storage battery products.

These products, thriving in today's dynamic online marketplace, set the pace outside established regulatory frameworks. By clarifying the regulatory grey areas for mobile, grid-interconnected plug-in equipment, we can establish an unambiguous framework that significantly enhances safety in contrast to the the current "guerrilla style" installations.

Including all "plug-in" vehicles, portable devices, and equipment within the NEC will allow us to legally support a safe and smart, interconnected future electric grid by fully including all bidirectional Distributed Energy Resources (DERs). This inclusion would enable lower- and moderate-income prosumers to participate in the electricity market, creating valid economic opportunities for these underserved communities.

Additionally, it would incentivize manufacturers to certify their products, thereby improving consumer protection.

Related Item

- Global FR 9093

Submitter Information Verification

Submitter Full Name: Michael Sterker

Organization: AG Mensch und Umwelt

Street Address:

City:

State:

Zip:

Submittal Date: Mon Aug 26 04:48:34 EDT 2024

Committee: NEC-P12



627.1 Scope.

[This article covers the electrical conductors and equipment connecting an electric self-propelled vehicle \(ESV\), or other electricity-generating appliances to premises wiring for the purposes of charging, power export, or bidirectional current flow.](#)

Statement of Problem and Substantiation for Public Comment

Merriam-Webster defines a vehicle as “a means of carrying or transporting something.”

However, the current language in the National Electric Code (NEC) excludes unpropelled vehicles, such as solar and battery trailers and carts, as well as portable electricity-generating household appliances. This exclusion lacks a scientifically sound rationale.

Unpropelled vehicles like carts, trailers, and cord-connected electricity-generating household appliances should be considered within the NEC's scope as Electric Vehicles (EVs). Without a compliant pathway through codes and standards, the market will likely continue to see the rise of “guerrilla” style solar and storage battery products.

These products, thriving in today's dynamic online marketplace, set the pace outside established regulatory frameworks. By clarifying the regulatory grey areas for mobile, grid-interconnected plug-in equipment, we can establish an unambiguous framework that significantly enhances safety in contrast to the the current “guerrilla style” installations.

Including all “plug-in” vehicles, portable devices, and equipment within the NEC will allow us to legally support a safe and smart, interconnected future electric grid by fully including all bidirectional Distributed Energy Resources (DERs). This inclusion would enable lower- and moderate-income prosumers to participate in the electricity market, creating valid economic opportunities for these underserved communities.

Additionally, it would incentivize manufacturers to certify their products, thereby improving consumer protection.

Related Item

- Global FR 9093

Submitter Information Verification

Submitter Full Name: Tim Glagau

Organization: Privat

Street Address:

City:

State:

Zip:

Submittal Date: Mon Aug 26 05:05:55 EDT 2024

Committee: NEC-P12



Public Comment No. 1664-NFPA 70-2024 [Section No. 627.1]

627.1 Scope.

This article covers the electrical conductors and equipment connecting an electric self-propelled vehicle (ESV) to premises wiring for the purposes of charging – power export, or bidirectional current flow.

Statement of Problem and Substantiation for Public Comment

Merriam-Webster defines a vehicle as “a means of carrying or transporting something.”

However, the current language in the National Electric Code (NEC) excludes unpropelled vehicles, such as solar and battery trailers and carts, as well as portable electricity-generating household appliances. This exclusion lacks a scientifically sound rationale.

Unpropelled vehicles like carts, trailers, and cord-connected electricity-generating household appliances should be considered within the NEC's scope as Electric Vehicles (EVs). Without a compliant pathway through codes and standards, the market will likely continue to see the rise of “guerrilla” style solar and storage battery products.

These products, thriving in today's dynamic online marketplace, set the pace outside established regulatory frameworks. By clarifying the regulatory grey areas for mobile, grid-interconnected plug-in equipment, we can establish an unambiguous framework that significantly enhances safety in contrast to the the current “guerrilla style” installations.

Including all “plug-in” vehicles, portable devices, and equipment within the NEC will allow us to legally support a safe and smart, interconnected future electric grid by fully including all bidirectional Distributed Energy Resources (DERs). This inclusion would enable lower- and moderate-income prosumers to participate in the electricity market, creating valid economic opportunities for these underserved communities.

Additionally, it would incentivize manufacturers to certify their products, thereby improving consumer protection.

Related Item

- Global FR 9093

Submitter Information Verification

Submitter Full Name: Holger Schmid

Organization: [Not Specified]

Street Address:

City:

State:

Zip:

Submittal Date: Mon Aug 26 05:15:08 EDT 2024

Committee: NEC-P12



Public Comment No. 1706-NFPA 70-2024 [Section No. 627.1]

627.1 Scope.

This article covers the electrical conductors and equipment connecting an electric self-propelled vehicle (ESV) or other electricity-generating appliances to premises wiring for the purposes of charging, power export, or bidirectional current flow.

Statement of Problem and Substantiation for Public Comment

Merriam-Webster defines a vehicle as “a means of carrying or transporting something.”

However, the current language in the National Electric Code (NEC) excludes unpropelled vehicles, such as solar and battery trailers and carts, as well as portable electricity-generating household appliances. This exclusion lacks a scientifically sound rationale.

Unpropelled vehicles like carts, trailers, and cord-connected electricity-generating household appliances should be considered within the NEC's scope as Electric Vehicles (EVs). Without a compliant pathway through codes and standards, the market will likely continue to see the rise of “guerrilla” style solar and storage battery products.

These products, thriving in today's dynamic online marketplace, set the pace outside established regulatory frameworks. By clarifying the regulatory grey areas for mobile, grid-interconnected plug-in equipment, we can establish an unambiguous framework that significantly enhances safety in contrast to the the current “guerrilla style” installations.

Including all “plug-in” vehicles, portable devices, and equipment within the NEC will allow us to legally support a safe and smart, interconnected future electric grid by fully including all bidirectional Distributed Energy Resources (DERs). This inclusion would enable lower- and moderate-income prosumers to participate in the electricity market, creating valid economic opportunities for these underserved communities.

Additionally, it would incentivize manufacturers to certify their products, thereby improving consumer protection.

Related Item

- Global FR 9093

Submitter Information Verification

Submitter Full Name: Jürgen Lessat

Organization: [Not Specified]

Affiliation: das journalistenbüro

Street Address:

City:

State:

Zip:

Submittal Date: Mon Aug 26 13:41:35 EDT 2024

Committee: NEC-P12



Public Comment No. 1712-NFPA 70-2024 [Section No. 627.1]

627.1 Scope.

This article covers the electrical conductors and equipment connecting an electric self-propelled vehicle (ESV) or other electricity-generating appliances to premises wiring for the purposes of charging, power export, or bidirectional current flow.

Statement of Problem and Substantiation for Public Comment

zur Web-Version

Mini-Solar-News
Aktuelle Informationen und Hintergründe zu

Mini-Solar-Kraftwerken

26.08.2024

In dieser Ausgabe:

Schick das Balkonkraftwerk übern großen Teich!
Deal der Woche: Gib deinen Alten in Zahlung!

Schick das Balkonkraftwerk übern größten Teich!

Disclaimer: Dieser Artikel beruht auf einem Text von Achim Ginsberg-Klemmt, GismoPower, den wir übersetzt, erweitert und an einigen Stellen angepasst haben.

Wenn du der Ansicht bist, dass Balkonkraftwerke auch in der größten Volkswirtschaft der Welt weit verbreitet und verfügbar sein sollten, dann läuft die Zeit ab, um hierfür deine Stimme zu erheben. Aktuell ist die Nutzung von Steckersolargeräten in den USA nämlich noch nicht so einfach möglich wie in Deutschland und die Frist für eine hierzu notwendige Anfrage zur Änderung des National Electric Code (NEC) endet am 28. August 2024, also diesen Mittwoch!

Die Änderung des NEC ist ein komplexer und langsamer Prozess, der oft durch restriktive Regeln behindert wird. Sicherheit ist ein zentrales Anliegen der National Fire Protection Association (NFPA), die den NEC überwacht. Der dringende Bedarf zur Reduzierung von Treibhausgasemissionen, zum Einsparen von Energie und zur Bereitstellung von erneuerbarer Energie für Mieter, kleine Unternehmen und Haushalte mit mittlerem Einkommen hingegen sind für die NFPA keine ausreichenden Gründe, um einen Freigabeprozess für Balkonkraftwerke von sich aus anzuregen.

Darüber kann man sich ärgern, das ändert aber meist wenig. Wenn du stattdessen lieber aktiv werden und selbst für die notwendigen Änderungen sorgen möchtest, dann findest du hier eine Schritt-für-Schritt-Anleitung, wie Du dazu beitragen kannst, das Balkonkraftwerk in die USA zu bringen:

Registriere dich auf der NFPA Webseite mit deinem bevorzugten Browser (Safari funktioniert nicht immer). Dazu klickst du unten Create an account, gibst deine Mailadresse ein, klickst auf Send verification code, trägst diesen Code, den du per Mail erhältst, ein und vervollständigst dann deine Daten in der Eingabemaske. Hinweis: Jetzt bist du ermächtigt, Änderungen am National Electric Code der USA einzureichen.

Klicke dann folgenden Link: <https://www.nfpa.org/codes-and-standards/nfpa-70-standard-development/70>

Wähle den Reiter Next Edition und klicke auf den Button Submit Public Comment Online.

Nach erneuter Bestätigung der Anmeldedaten, erweitere im linken Menü Chapter 6 - Special Equipment mit + und wähle dann Article 627 Electric Self-Propelled Vehicle Power Transfer Systems (ESVSEs) aus.

Hinweis: Während sich dieser Artikel derzeit auf Fahrzeug-Strom-Transfer-Systeme konzentriert, kann er ganz einfach erweitert werden, um Steckersolargeräte einzubeziehen.

Setze nun den Haken bei Punkt 627.1 Scope und drücke unten den Button Revise First Draft Section(s). Lösche dann den kompletten Text außer der Überschrift und ersetze ihn durch folgenden:

This article covers the electrical conductors and equipment connecting an electric self-propelled vehicle (ESV) or other electricity-generating appliances to premises wiring for the purposes of charging, power export, or bidirectional current flow.

Klicke dann auf Next. Dort wird dir die Änderung zum bisherigen Text angezeigt. Klicke zwei weitere Male auf Next bis zur Überschrift Statement of Problem and Substantiation for Public Comment (Required). Füge dort folgenden Text ein:

Merriam-Webster defines a vehicle as "a means of carrying or transporting something." However, the current language in the National Electric Code (NEC) excludes unpropelled vehicles, such as solar and battery trailers and carts, as well as portable electricity-generating household appliances. This exclusion lacks a scientifically sound rationale.

Unpropelled vehicles like carts, trailers, and cord-connected electricity-generating household appliances should be considered within the NEC's scope as Electric Vehicles (EVs). Without a compliant pathway through codes and standards, the market will likely continue to see the rise of "guerrilla" style solar and storage battery products.

These products, thriving in today's dynamic online marketplace, set the pace outside established regulatory frameworks. By clarifying the regulatory grey areas for mobile, grid-interconnected plug-in equipment, we can establish an unambiguous framework that significantly enhances safety in contrast to the the current "guerrilla style" installations.

Including all "plug-in" vehicles, portable devices, and equipment within the NEC will allow us to legally support a safe and smart, interconnected future electric grid by fully including all bidirectional Distributed Energy Resources (DERs). This inclusion would enable lower- and moderate-income prosumers to participate in the electricity market, creating valid economic opportunities for these underserved communities.

Additionally, it would incentivize manufacturers to certify their products, thereby improving consumer protection.

Related Item

- Global FR 9093

Submitter Information Verification

Submitter Full Name: Rene Gensert

Organization: Private

Street Address:

City:

State:

Zip:

Submittal Date: Mon Aug 26 14:37:02 EDT 2024

Committee: NEC-P12



Public Comment No. 1813-NFPA 70-2024 [Section No. 627.1]

627.1 Scope.

This article covers the electrical conductors and equipment connecting an electric self-propelled vehicle (ESV) or other electricity-generating appliances to premises wiring for the purposes of charging, power export, or bidirectional current flow.

Statement of Problem and Substantiation for Public Comment

Merriam-Webster defines a vehicle as “a means of carrying or transporting something.”

However, the current language in the National Electric Code (NEC) excludes unpropelled vehicles, such as solar and battery trailers and carts, as well as portable electricity-generating household appliances. This exclusion lacks a scientifically sound rationale.

Unpropelled vehicles like carts, trailers, and cord-connected electricity-generating household appliances should be considered within the NEC's scope as Electric Vehicles (EVs). Without a compliant pathway through codes and standards, the market will likely continue to see the rise of “guerrilla” style solar and storage battery products.

These products, thriving in today's dynamic online marketplace, set the pace outside established regulatory frameworks. By clarifying the regulatory grey areas for mobile, grid-interconnected plug-in equipment, we can establish an unambiguous framework that significantly enhances safety in contrast to the the current “guerrilla style” installations.

Including all “plug-in” vehicles, portable devices, and equipment within the NEC will allow us to legally support a safe and smart, interconnected future electric grid by fully including all bidirectional Distributed Energy Resources (DERs). This inclusion would enable lower- and moderate-income prosumers to participate in the electricity market, creating valid economic opportunities for these underserved communities.

Additionally, it would incentivize manufacturers to certify their products, thereby improving consumer protection.

Related Item

- Global FR 9093

Submitter Information Verification

Submitter Full Name: Pete Kern

Organization: onlinesolarschool

Street Address:

City:

State:

Zip:

Submittal Date: Tue Aug 27 14:17:22 EDT 2024

Committee: NEC-P12



Public Comment No. 1910-NFPA 70-2024 [Section No. 627.1]

627.1 Scope.

This article covers the electrical conductors and equipment connecting an electric self-propelled vehicle (ESV) or other electricity-generating appliances to premises wiring for the purposes of charging, power export, or bidirectional current flow.

Statement of Problem and Substantiation for Public Comment

Merriam-Webster defines a vehicle as “a means of carrying or transporting something.”

However, the current language in the National Electric Code (NEC) excludes unpropelled vehicles, such as solar and battery trailers and carts, as well as portable electricity-generating household appliances. This exclusion lacks a scientifically sound rationale.

Unpropelled vehicles like carts, trailers, and cord-connected electricity-generating household appliances should be considered within the NEC's scope as Electric Vehicles (EVs). Without a compliant pathway through codes and standards, the market will likely continue to see the rise of “guerrilla” style solar and storage battery products.

These products, thriving in today's dynamic online marketplace, set the pace outside established regulatory frameworks. By clarifying the regulatory grey areas for mobile, grid-interconnected plug-in equipment, we can establish an unambiguous framework that significantly enhances safety in contrast to the the current “guerrilla style” installations.

Including all “plug-in” vehicles, portable devices, and equipment within the NEC will allow us to legally support a safe and smart, interconnected future electric grid by fully including all bidirectional Distributed Energy Resources (DERs). This inclusion would enable lower- and moderate-income prosumers to participate in the electricity market, creating valid economic opportunities for these underserved communities.

Additionally, it would incentivize manufacturers to certify their products, thereby improving consumer protection.

Related Item

- Global FR 9093

Submitter Information Verification

Submitter Full Name: Benedikt Brecht

Organization:

Street Address:

City:

State:

Zip:

Submittal Date: Wed Aug 28 06:54:30 EDT 2024

Committee: NEC-P12



Public Comment No. 1200-NFPA 70-2024 [Section No. 627.4]

627.4 Voltages.

~~Unless other voltages are specified, the nominal ac system voltages of 120, 120/240, 208Y/120, 240, 480Y/277, 480, 600Y/347, 600, or 1000 volts or dc system input voltages of up to 1000 volts shall be used to supply equipment covered by Article 627.~~

~~Output voltages to the ESV are not specified.~~

Statement of Problem and Substantiation for Public Comment

The purpose of this comment is to delete 627.4. Since 627.2 requires ESVSE to be listed, there is no need for the NEC to identify what voltages are suitable to supply ESVSE. Supply voltage criteria is clearly outlined in the applicable safety product standard the ESVSE is listed to. This section is superfluous and adds no value to the code.

Related Item

- FR9039

Submitter Information Verification

Submitter Full Name: Megan Hayes

Organization: NEMA

Street Address:

City:

State:

Zip:

Submittal Date: Sat Aug 17 00:33:46 EDT 2024

Committee: NEC-P12



Public Comment No. 401-NFPA 70-2024 [Section No. 627.17(A)]

(A) Power-Supply Cords.

Cables for cord-connected ESVSE shall comply with all of the following:

- (1) Be any of the types specified in 627.17(B)(1) or hard service cord, junior hard service cord, or portable power cable types in accordance with Table 400.4. Hard service cord, junior hard service cord, or portable power cable types shall be listed, as applicable, for exposure to oil and damp and wet locations.
- (2) Have an ampacity as specified in Table 400.5(A)(1) or, for 8 AWG and larger, in the 60°C (140°F) columns of Table 400.5(A)(2)
- (3) Have an overall length as specified in either of the following: ~~When the interrupting device of the~~ a personnel protection system ~~specified in 627.22 is located within the enclosure of the supply equipment or charging system, the power supply cord is not more than indicated in either of the following:~~
 - (4) ~~For portable equipment in accordance with 627.44(A) ,not more than 300 mm (12 in.) long~~
 - (5) ~~For fastened-in-place equipment in accordance with 627.44(B) 627.44(D), not more than 1.8 m (6 ft) long, with equipment installed at a height that prevents the power supply cord from contacting the floor when it is connected to the proper receptacle~~

~~When the interrupting device of the personnel protection system specified in 627.22 is located at the~~ ESVSE, at the attachment plug, or within the first 300 mm (12 in.) of the power ~~supply cord ,not more than 4.6 m (15 ft) long and have an overall length not exceeding 15.25 m (50 feet).~~

Statement of Problem and Substantiation for Public Comment

The requirements in Article 627 are derived from Article 625. This was done because essentially the same technology is being used to charge other vehicles that fall outside the definition of an electric vehicle in Article 100, thereby falling outside the scope of Article 625. These other vehicles were addressed in the new proposed Article 627 with the idea that the basic requirements should be the same but that there is room for flexibility since some of these vehicles will demand a different approach. For example, when charging aircraft the cord length limitation cannot be upheld since the charger will not be able to get close enough to the aircraft. Due to wingspan of the aircraft, the aircraft cannot be parked closer to the wall receptacle. A second example has to do with industrial trucks that are charged with equipment within an industrial environment with trained and knowledgeable persons such that the prohibitions for cord length for use with the general public do not apply. Similar examples exist for construction equipment and agricultural equipment. Just based on general use cases for this equipment, the current cord length limitations will create issues and force people into using extension cords which should be avoided.

Additionally, the use cases covered under Article 627 are for vehicle types that will not be primarily charged or operated by the general public. The equipment is installed in a more controlled location with knowledgeable people that can be trained to avoid hazards. With this in mind, the overly stringent requirement for limiting the power supply cord to a total of 12 inches if the interrupting device of the personnel protection system is located inside the enclosure of the equipment is no longer needed.

Related Item

- FR9039

Submitter Information Verification

Submitter Full Name: Joseph Bablo

Organization: UL Solutions

Street Address:

City:

State:

Zip:

Submittal Date: Tue Jul 30 15:05:57 EDT 2024

Committee: NEC-P12



Public Comment No. 1201-NFPA 70-2024 [Section No. 627.42]

627.42 Rating.

ESVSE shall have sufficient rating to supply the load served. Charging loads shall be considered continuous loads for the purposes of this article. Service and feeders shall be sized in accordance with the product ratings, unless the overall rating of the installation can be limited through controls as permitted by 627.42(A) or 627.42(B).

(A) Energy Management System (EMS).

Where energy management systems (EMSs) in accordance with ~~430.30 provide~~ Article 130, Part II, provide load management of ESVSE, the maximum equipment load on service and feeders shall be the maximum load permitted by the EMS. EMSs shall be permitted to be integral to one piece of equipment or integral to listed systems consisting of more than one piece of equipment. When one or more pieces of equipment are provided with integral load management control, systems shall be marked to indicate such control is provided.

(B) Supply Equipment with Adjustable Settings.

Supply equipment with restricted access to an ampere adjusting means complying with 130.30 ~~70 (B)~~ shall be permitted. If adjustments have an impact on the rating label, such changes shall comply with manufacturer's instructions, with the adjusted rating appearing on the rating label with sufficient durability to withstand the environment involved. Such supply equipment shall be permitted to have ampere ratings that are equal to the adjusted current setting.

Statement of Problem and Substantiation for Public Comment

CMP-13 moved some of the requirements referenced to Article 750, Part II in FR 8095. The CC then moved the Article 750 to 130 in FCR 218.

The Public Comment improves the clarity by specifically referencing the subdivision that contains list of restricted access means. Secondly, this Public Comment maintains correlation by updating the section numbers to align with the rearrangements made by other committees.

Related Item

- FR9039

Submitter Information Verification

Submitter Full Name: Megan Hayes

Organization: NEMA

Street Address:

City:

State:

Zip:

Submittal Date: Sat Aug 17 00:36:21 EDT 2024

Committee: NEC-P12



Public Comment No. 650-NFPA 70-2024 [Section No. 627.42]

627.42 Rating.

ESVSE shall have sufficient rating to supply the load served. Charging loads shall be considered continuous loads for the purposes of this article. Service and feeders shall be sized in accordance with the product ratings, unless the overall rating of the installation can be limited through controls as permitted by 627.42(A) or 627.42(B).

(A) Energy Management System (EMS).

Where energy management systems (EMSs) in accordance with 130.30 provide load management of ESVSE, the maximum equipment load on service and feeders shall be the maximum load permitted by the EMS. EMSs shall be permitted to be integral to one piece of equipment or integral to listed systems consisting of more than one piece of equipment. When one or more pieces of equipment are provided with integral load management control, systems shall be marked to indicate such control is provided.

(B) Supply Equipment with Adjustable Settings.

Supply equipment with restricted access to an ampere adjusting means complying with 130.30(C) shall be permitted. If adjustments have an impact on the rating label, such changes shall comply with manufacturer's instructions, with the adjusted rating appearing on the rating label with sufficient durability to withstand the environment involved. Such supply equipment shall be permitted to have ampere ratings that are equal to the adjusted current setting.

Additional Proposed Changes

<u>File Name</u>	<u>Description</u>	<u>Approved</u>
CN_346.pdf		

Statement of Problem and Substantiation for Public Comment

NOTE: The following CC Note No. 346 appeared in the First Draft Report.

The requirements in this section should be revised to align the terminology with Article 130, Part II, "EMS with PCS", as determined by CMP 13.

Related Item

- Correlating Committee Note No. 346

Submitter Information Verification

Submitter Full Name: CC Notes
Organization: NEC Correlating Committee
Street Address:
City:
State:
Zip:
Submittal Date: Fri Aug 02 09:20:19 EDT 2024
Committee: NEC-P12



Correlating Committee Note No. 346-NFPA 70-2024 [Section No. 627.42]

Submitter Information Verification

Committee: NEC-AAC

Submittal Date: Fri May 10 08:07:21 EDT 2024

Committee Statement

Committee Statement: The requirements in this section should be revised to align the terminology with Article 130, Part II, "EMS with PCS", as determined by CMP 13.

Ballot Results

✔ This item has passed ballot

12 Eligible Voters

1 Not Returned

11 Affirmative All

0 Affirmative with Comments

0 Negative with Comments

0 Abstention

Not Returned

McDaniel, Roger D.

Affirmative All

Ayer, Lawrence S.

Bowmer, Trevor N.

Hickman, Palmer L.

Holub, Richard A.

Jackson, Peter D.

Kendall, David H.

Manche, Alan

Osborne, Robert D.

Porter, Christine T.

Schultheis, Timothy James

Williams, David A.



Public Comment No. 651-NFPA 70-2024 [Section No. 630.2]

630.2 Listing Requirements.

All welding and cutting power equipment under the scope of this article shall be listed.

Additional Proposed Changes

<u>File Name</u>	<u>Description</u>	<u>Approved</u>
CN_347.pdf		

Statement of Problem and Substantiation for Public Comment

NOTE: The following CC Note No. 347 appeared in the First Draft Report on First Revision No. 8732.

CMP 12 is requested to review the phrase "under the scope of this article" as it appears to be redundant text, because the listing requirement specifically applies to this article. In addition, it is noted that "laser welding" equipment is not specifically listed in the Scope Statement, though it may be considered "other similar equipment". As such, the panel is asked to review the scope statement for completeness in respect to available technology.

Related Item

- First Revision No. 8732

Submitter Information Verification

Submitter Full Name: CC Notes

Organization: NEC Correlating Committee

Street Address:

City:

State:

Zip:

Submittal Date: Fri Aug 02 09:22:15 EDT 2024

Committee: NEC-P12



Correlating Committee Note No. 347-NFPA 70-2024 [Section No. 630.2]

Submitter Information Verification

Committee: NEC-AAC

Submittal Date: Fri May 10 08:08:09 EDT 2024

Committee Statement

Committee Statement: CMP 12 is requested to review the phrase “under the scope of this article” as it appears to be redundant text, because the listing requirement specifically applies to this article. In addition, it is noted that “laser welding” equipment is not specifically listed in the Scope Statement, though it may be considered “other similar equipment”. As such, the panel is asked to review the scope statement for completeness in respect to available technology.

First Revision No. 8732-NFPA 70-2024 [Section No. 630.6]

Ballot Results

✓ **This item has passed ballot**

12 Eligible Voters

1 Not Returned

11 Affirmative All

0 Affirmative with Comments

0 Negative with Comments

0 Abstention

Not Returned

McDaniel, Roger D.

Affirmative All

Ayer, Lawrence S.

Bowmer, Trevor N.

Hickman, Palmer L.

Holub, Richard A.

Jackson, Peter D.

Kendall, David H.

Manche, Alan

Osborne, Robert D.

Porter, Christine T.

Schultheis, Timothy James



Public Comment No. 810-NFPA 70-2024 [Section No. 630.8]

~~630.8 – Ground-Fault Circuit-Interrupter Protection for Personnel:~~

~~All 125-volt, 15- and 20-ampere receptacles for electrical hand tools or portable lighting equipment, supplied by single-phase branch circuits rated 150 volts or less to ground, installed in work areas where welders are operated shall have ground-fault circuit-interrupter protection for personnel.~~

Statement of Problem and Substantiation for Public Comment

As indicated by multiple PIs by multiple people, the scope of this article does not cover the area around a welder. If the committee wishes it to include those areas it should change the scope in 630.1.

These PIs were rejected with a panel statement that says "GFCI protection is critical to the proper use of welding equipment." Electric welding predates the NEC. How critical can it be? GFCI certainly provides protection against electric shock, but we were fine for over 120 years without it in this article, so how is it critical? As indicated in the negative vote by Karl Reighard when this rule was put in, there are no documented incidents of electrocutions or even electric shocks. You would think that over 120 years the committee could point to at least one incident if this was truly "critical to the proper use of welding equipment."

And why did the committee choose to not even acknowledge the fact that 630.1 indicates that Article 630 applies only to the equipment doing the welding, cutting, etc.?

Related Item

- PI 577

Submitter Information Verification

Submitter Full Name: Ryan Jackson

Organization: Self-employed

Street Address:

City:

State:

Zip:

Submittal Date: Mon Aug 05 16:00:39 EDT 2024

Committee: NEC-P12



Public Comment No. 653-NFPA 70-2024 [Sections 640.1, 640.4]

Sections 640.1, 640.4

640.1 Scope.

(A) Covered.

This article covers equipment and wiring for audio signal generation, recording, processing, amplification, and reproduction; distribution of sound; public address; speech input systems; temporary audio system installations; and electronic organs or other electronic musical instruments.

Informational Note: Examples of permanently installed distributed audio system locations include, but are not limited to, restaurant, hotel, business office, commercial and retail sales environments, churches, and schools. Both portable and permanently installed equipment locations include, but are not limited to, residences, auditoriums, theaters, stadiums, and movie and television studios. Temporary installations include, but are not limited to, auditoriums, theaters, stadiums (which use both temporary and permanently installed systems), and outdoor events such as fairs, festivals, circuses, public events, and concerts.

(B) Not Covered.

This article does not cover the installation and wiring of fire and burglary alarm signaling devices.

640.4 Locations and Other Articles.

Circuits and equipment shall comply with 640.4(A) through 640.4(J), as applicable.

(A) Spread of Fire or Products of Combustion.

Section 300.23 shall apply.

(B) Ducts, Plenums, and Other Air-Handling Spaces.

Section 300.25(B) shall apply to circuits and equipment installed in ducts specifically fabricated for environmental air. Section 300.25(C) shall apply to circuits and equipment installed in other spaces used for environmental air (plenums).

Exception No. 1: Class 2 and Class 3 cables installed in accordance with 794.135(A) shall be permitted to be installed in ducts specifically fabricated for environmental air.

Exception No. 2: Class 2 and Class 3 cables installed in accordance with 794.135(A) shall be permitted to be installed in other spaces used for environmental air (plenums).

Informational Note: See NFPA 90A-2024, *Standard for the Installation of Air-Conditioning and Ventilating Systems*, 8.5.5.6, which permits loudspeakers, loudspeaker assemblies, and their accessories listed in accordance with UL 2043-2023, *Fire Test for Heat and Visible Smoke Release for Discrete Products and Their Accessories Installed in Air-Handling Spaces*, to be installed in other spaces used for environmental air (ceiling cavity plenums).

(C) Communications Cables.

Types CMP, CMR, CMG, and CM communications cables shall be permitted to substitute for Class 2 and Class 3 cables in accordance with 794.135(D).

(D) Cable Trays.

Cable trays and cable tray systems shall be installed in accordance with Article 392, Part II. The installation of Class 2, Class 3, and Type PLTC cables in cable trays shall be in accordance with 794.135(A).

(E) Hazardous (Classified) Locations.

Equipment used in hazardous (classified) locations shall comply with the applicable requirements of Chapter 5.

(F) Special Occupancies.

Audio equipment used in special occupancies shall comply with the requirements in the associated special occupancy article in Chapter 5.

(G) Combination Systems.

Where the authority having jurisdiction permits audio systems for paging or music, or both, to be combined with fire alarm systems, the wiring shall comply with 760.139(E).

Informational Note: See NFPA 72-2025, *National Fire Alarm and Signaling Code*, and NFPA 101-2024, *Life Safety Code*, for installation requirements for such combination systems.

(H) Antennas.

Equipment used in audio systems that contain an audio or video tuner and an antenna input shall comply with the Chapter 8 requirements. Wiring other than antenna wiring that connects such equipment to other audio equipment shall comply with this article.

(I) Generators.

Generators shall be installed in accordance with 445.10 through 445.12, 445.14 through 445.16, and 445.18. Grounding of portable and vehicle-mounted generators shall be in accordance with 250.34.

(J) Organ Pipes.

Additions of pipe organ pipes to an electronic organ shall be in accordance with 650.5 through 650.10.

Additional Proposed Changes

<u>File Name</u>	<u>Description</u>	<u>Approved</u>
CN_349.pdf		

Statement of Problem and Substantiation for Public Comment

NOTE: The following CC Note No. 349 appeared in the First Draft Report on First Revision No. 8486 and First Revision No. 8483.

The Correlating Committee directs the chair of CMP 12 to form a task group consisting of members from CMPs 12, 14, 15, and 17 to review and correlate the audio equipment installation requirements in Article 640 with any requirements for audio equipment in the special occupancy and special equipment articles under the purview these CMPs.

Related Item

• First Revision No. 8486 • First Revision No. 8483

Submitter Information Verification

Submitter Full Name: CC Notes

Organization: NEC Correlating Committee

Street Address:

City:

State:

Zip:

Submittal Date: Fri Aug 02 09:24:07 EDT 2024

Committee: NEC-P12



Correlating Committee Note No. 349-NFPA 70-2024 [Sections 640.1, 640.4]

Submitter Information Verification

Committee: NEC-AAC

Submittal Date: Fri May 10 08:30:09 EDT 2024

Committee Statement

Committee Statement: The Correlating Committee directs the chair of CMP 12 to form a task group consisting of members from CMPs 12, 14, 15, and 17 to review and correlate the audio equipment installation requirements in Article 640 with any requirements for audio equipment in the special occupancy and special equipment articles under the purview these CMPs.

First Revision No. 8486-NFPA 70-2024 [Section No. 640.3]

First Revision No. 8483-NFPA 70-2024 [Section No. 640.1(A)]

Ballot Results

✓ **This item has passed ballot**

12 Eligible Voters

1 Not Returned

11 Affirmative All

0 Affirmative with Comments

0 Negative with Comments

0 Abstention

Not Returned

McDaniel, Roger D.

Affirmative All

Ayer, Lawrence S.

Bowmer, Trevor N.

Hickman, Palmer L.

Holub, Richard A.

Jackson, Peter D.

Kendall, David H.

Manche, Alan

Osborne, Robert D.

Porter, Christine T.

Schultheis, Timothy James



Public Comment No. 404-NFPA 70-2024 [Section No. 640.4]

640.4 Locations and Other Articles.

Circuits and equipment shall comply with 640.4(A) through 640.4(J), as applicable.

~~(B)~~

~~(A) Spread of Fire or Products of Combustion:~~

~~Section 300.23 shall apply.~~

Ducts, Plenums, and Other Air-Handling Spaces.

Section 300.25(B) shall apply to circuits and equipment installed in ducts specifically fabricated for environmental air. Section 300.25(C) shall apply to circuits and equipment installed in other spaces used for environmental air (plenums).

Exception No. 1: Class 2 and Class 3 cables installed in accordance with 794.135(A) shall be permitted to be installed in ducts specifically fabricated for environmental air.

Exception No. 2: Class 2 and Class 3 cables installed in accordance with 794.135(A) shall be permitted to be installed in other spaces used for environmental air (plenums).

Informational Note: See NFPA 90A-2024, *Standard for the Installation of Air-Conditioning and Ventilating Systems*, 8.5.5.6, which permits loudspeakers, loudspeaker assemblies, and their accessories listed in accordance with UL 2043-2023, *Fire Test for Heat and Visible Smoke Release for Discrete Products and Their Accessories Installed in Air-Handling Spaces*, to be installed in other spaces used for environmental air (ceiling cavity plenums).

~~(B)~~ Communications Cables.

Types CMP, CMR, CMG, and CM communications cables shall be permitted to substitute for Class 2 and Class 3 cables in accordance with 794.135(D).

~~(C)~~ Cable Trays.

Cable trays and cable tray systems shall be installed in accordance with Article 392, Part II. The installation of Class 2, Class 3, and Type PLTC cables in cable trays shall be in accordance with 794.135(A).

~~(E)~~

~~(E) Hazardous (Classified) Locations:~~

~~Equipment used in hazardous (classified) locations shall comply with the applicable requirements of Chapter 5 :~~

~~(F) Special Occupancies:~~

~~Audio equipment used in special occupancies shall comply with the requirements in the associated special occupancy article in Chapter 5 :~~

D) Combination Systems.

Where the authority having jurisdiction permits audio systems for paging or music, or both, to be combined with fire alarm systems, the wiring shall comply with 760.139(E).

Informational Note: See *NFPA 72-2025, National Fire Alarm and Signaling Code*, and *NFPA 101-2024, Life Safety Code*, for installation requirements for such combination systems.

~~(H)~~ Antennas.

Equipment used in audio systems that contain an audio or video tuner and an antenna input shall comply with the Chapter 8 requirements. Wiring other than antenna wiring that connects such equipment to other audio equipment shall comply with this article.

~~(I)~~ Generators.

Generators shall be installed in accordance with 445.10 through 445.12, 445.14 through 445.16, and 445.18. Grounding of portable and vehicle-mounted generators shall be in accordance with 250.34.

~~(J)~~ Organ Pipes.

Additions of pipe organ pipes to an electronic organ shall be in accordance with 650.5 through 650.10.

Statement of Problem and Substantiation for Public Comment

First Revision 8486 modified 640.4 in order to remove references to complete articles in accordance with 4.1.4 of the Style Manual. A number of items were simply deleted because the reference to the complete article was a reference to portions of the code that are required to apply anyway in accordance with 90.3. As such, no reference is needed in Article 640. However, in doing this, the panel missed the opportunity to remove other similar references. As such, additional deletions are warranted.

Item (A) points to 300.23 which is required to be applied by 90.3. A reference here is not needed.

Item (E) points to Chapter 5 for hazardous locations. If the product is used within a hazardous location, then Chapter 5 applies without reference.

Item (F) points to Chapter 5 for special occupancies, and again, if those special occupancies apply, then Chapter 5 applies without reference.

Items (A), (E), and (F) can therefore be deleted and all remaining items can be revised as shown.

Related Item

- FR8486

Submitter Information Verification

Submitter Full Name: Joseph Bablo

Organization: UL Solutions

Street Address:

City:

State:

Zip:

Submittal Date: Tue Jul 30 15:16:23 EDT 2024

Committee: NEC-P12



Public Comment No. 1102-NFPA 70-2024 [Section No. 645.4(A)]

(A) Spread of Fire or Products of Combustion.

Sections 300.23, ~~770.26~~, and ~~800.26~~ 720.26-21, shall apply to penetrations of the fire-resistant room boundary.

Statement of Problem and Substantiation for Public Comment

Sections 770.26 and 800.26 are deleted in the First Draft report. Spread of Fire for limited-energy cables is in 720.21.

Related Public Comments for This Document

<u>Related Comment</u>	<u>Relationship</u>
Public Comment No. 1103-NFPA 70-2024 [Section No. 646.4(A)]	
Public Comment No. 1103-NFPA 70-2024 [Section No. 646.4(A)]	

Related Item

- FCR-228 • FCR-232

Submitter Information Verification

Submitter Full Name: Stanley Kaufman
Organization: CableSafe, Inc./OFS
Affiliation: Plastics Industry Association (PLASTICS)
Street Address:
City:
State:
Zip:
Submittal Date: Thu Aug 15 02:56:52 EDT 2024
Committee: NEC-P12



Public Comment No. 1104-NFPA 70-2024 [Section No. 645.4(B)]

(B) Wiring and Cabling in Other Spaces Used for Environmental Air (Plenums).

The following sections and tables shall apply to wiring and cabling in other spaces used for environmental air (plenums) above an information technology equipment room:

- (1) Wiring methods: 300.25(C)(1)
- (2) ~~Class 2, Class 3, and Class 4 Limited-energy~~ cables: ~~794.722, 435.131 (A B)~~
Fire alarm systems
- (3) ~~and Table 722.120~~
- (4) ~~Non-power-limited fire alarm cables : 760.53(B)(2) and Table 794.320~~
- (5) ~~Optical fiber cables: 770.113(C) and Table 770.154(a)~~
- (6) ~~Communications circuits: 800.133(C) and Table 800.154(a)~~
- (7) ~~CATV and radio distribution systems: 800.113(C) and Table 800.154(a)~~

Statement of Problem and Substantiation for Public Comment

Most of the cables in this section are limited-energy cables. These cables have one set of installation rules in 722.131(B) and Table 722.120.

Since power-limited fire alarm cable are limited-energy cables, non-power-limited fire alarm cables need reference in this section, 760.53(B)(2).

Related Public Comments for This Document

Related Comment

[Public Comment No. 1105-NFPA 70-2024 \[Section No. 646.4\(B\)\]](#)

[Public Comment No. 1105-NFPA 70-2024 \[Section No. 646.4\(B\)\]](#)

Relationship

Related Item

• FCR-228 • FCR-232

Submitter Information Verification

Submitter Full Name: Stanley Kaufman

Organization: CableSafe, Inc./OFS

Affiliation: Plastics Industry Association (PLASTICS)

Street Address:

City:

State:

Zip:

Submittal Date: Thu Aug 15 05:47:20 EDT 2024

Committee: NEC-P12



Public Comment No. 1484-NFPA 70-2024 [Section No. 645.4(B)]

(B) Wiring and Cabling in Other Spaces Used for Environmental Air (Plenums).

The following sections and tables shall apply to wiring and cabling in other spaces used for environmental air (plenums) above an information technology equipment room:

- (1) Wiring methods: 300.25(C)(1)
- (2) PLTC, Class 2, Class 3, and Class 4 cables: 794.135(A)
- (3) Fire alarm systems: 760.53(B)(2) and Table 794.320
- (4) Optical fiber cables: 770.113(C) and Table 770.154(a)
- (5) Communications circuits: 800.133(C) and Table 800.154(a)
- (6) CATV and radio distribution systems: 800.113(C) and Table 800.154(a)

Statement of Problem and Substantiation for Public Comment

There was no substantiation to remove PLTC type cables in this space. The committee removed this without justification or discussion.

Related Item

- FR8520

Submitter Information Verification

Submitter Full Name: Joel Goergen

Organization: Cisco Systems, Inc.

Affiliation: Cisco Systems, Inc.

Street Address:

City:

State:

Zip:

Submittal Date: Fri Aug 23 14:25:43 EDT 2024

Committee: NEC-P12



Public Comment No. 1106-NFPA 70-2024 [Section No. 645.4(E)]

(E).

~~Fire~~

Limited-Energy Cables. Limited-energy cables in an information technology room shall be listed in accordance with 722.2, and installed in accordance with 722.131 and Table 722.120.

(F) Fire Alarm Cables and Equipment.

Article 760, Parts I, II, and III shall apply to Power-limited fire alarm

~~systems~~
~~cables~~

~~and equipment installed~~
~~in an information technology equipment room~~

~~Only fire alarm cables listed in~~
~~shall be listed and installed in accordance with 645.4(E). Non-power-limited fire alarm circuits in an information technology room shall be installed in~~
~~accordance with Article 760, Part~~

~~IV and listed fire alarm equipment shall be permitted to be installed~~
~~II. Power-limited fire alarm circuits, in an information technology~~

~~equipment room~~
~~room shall be installed in accordance with Article 760, Part III.~~

Statement of Problem and Substantiation for Public Comment

Since power-limited fire alarm cables are limited-energy cables, and non-power-limited fire alarm cables are not limited-energy cables, the recommended text divides 645.4(E) into two sections, (E) which covers all limited-energy cables, and new (F) that covers non-power-limited fire alarm circuits (including non-power-limited fire alarm cables).

Related Public Comments for This Document

Related Comment

[Public Comment No. 1111-NFPA 70-2024 \[Section No. 646.4\(E\)\]](#)

[Public Comment No. 1111-NFPA 70-2024 \[Section No. 646.4\(E\)\]](#)

Related Item

- FCR-228 • FCR-232

Relationship

Submitter Information Verification

Submitter Full Name: Stanley Kaufman

Organization: CableSafe, Inc./OFS

Affiliation: Plastics Industry Association (PLASTICS)

Street Address:

City:

State:

Zip:

Submittal Date: Thu Aug 15 06:26:20 EDT 2024

Committee: NEC-P12



(
F
G)

Cable Routing Assemblies

and Communications

Wires, Cables,
Raceways

~~and Equipment. Sections 800.110, 800.113, and 800.154 shall apply to cable
Cable routing assemblies and communications raceways~~

~~Article 800, Parts I, II, III, IV, and V and Article 805, Parts I, II, III, IV, and V shall apply to communications wires, cables, and equipment installed
in an information technology equipment room~~

~~Only communications wires and cables
shall be listed in accordance with~~

~~800.170, cable routing assemblies, communications raceways listed
Article 723, Part II, and installed in accordance with~~

~~800.182, and communications equipment listed in accordance with 800.171 shall be permitted to be installed in
Article 723, Part III.~~

~~(H) **Communications Equipment.** Communications equipment in an information technology equipment room shall be listed in accordance with 720.2
This Article~~

~~645
shall apply to the powering of communications equipment in an information technology equipment room.~~

~~Informational Note: See Article 100 for a definition of communications equipment.~~

Statement of Problem and Substantiation for Public Comment

The First Draft Report includes cable routing assemblies and communications raceways in Article 722. However, they are outside the scope of the Article 722, since Article 722 only covers cables. We have submitted PC 52 to create Article 723 which covers cable routing assemblies and communications raceways exclusively.

The requirements for listing communications equipment have been moved to Article 720.

Related Public Comments for This Document

<u>Related Comment</u>	<u>Relationship</u>
Public Comment No. 1112-NFPA 70-2024 [Section No. 646.4(E)]	
Public Comment No. 1112-NFPA 70-2024 [Section No. 646.4(F)]	
<u>Related Item</u>	
• FCR-228 • FCR-232	

Submitter Information Verification

Submitter Full Name: Stanley Kaufman
Organization: CableSafe, Inc./OFS
Affiliation: Plastics Industry Association (PLASTICS)
Street Address:
City:
State:
Zip:
Submittal Date: Thu Aug 15 08:12:34 EDT 2024
Committee: NEC-P12



Public Comment No. 1113-NFPA 70-2024 [Sections 645.4(G), 645.4(H)]

Sections 645.4(G), 645.4(H)

~~(G) Community Antenna Television and Radio Distribution Systems Coaxial Cables and Equipment:~~

~~Article 800 , Parts I, II, III, IV, and V and Article 820 , Parts I, II, III, IV, and V shall apply to community antenna television and radio distribution systems coaxial cables and equipment installed in an information technology equipment room. Only community antenna television and radio distribution coaxial cables listed in accordance with 800.179 and listed CATV equipment shall be permitted to be installed in an information technology equipment room. Article 645 shall apply to the powering of community antenna television and radio distribution systems equipment installed in an information technology equipment room.~~

~~(H) Optical Fiber Cables:~~

~~Only optical fiber cables listed in accordance with 770.179 shall be permitted to be installed in an information technology equipment room.~~

Statement of Problem and Substantiation for Public Comment

Optical fiber cables and CATV-type coaxial cables are limited-energy cables that are covered under revised 645.4(E). CATV equipment is communications equipment that are covered under revised 645.4(F).

Related Public Comments for This Document

Related Comment

Relationship

[Public Comment No. 1114-NFPA 70-2024 \[Section No. 646.4\(G\)\]](#)

[Public Comment No. 1114-NFPA 70-2024 \[Section No. 646.4\(G\)\]](#)

Related Item

• FCR-228 • FCR-232

Submitter Information Verification

Submitter Full Name: Stanley Kaufman

Organization: CableSafe, Inc./OFS

Affiliation: Plastics Industry Association (PLASTICS)

Street Address:

City:

State:

Zip:

Submittal Date: Thu Aug 15 09:15:40 EDT 2024

Committee: NEC-P12



Public Comment No. 1115-NFPA 70-2024 [Section No. 645.5]

645.5 Special Requirements for Information Technology Equipment Room.

The alternative wiring methods to Chapter 3 and Article ~~725~~ 720, ~~Parts I and II for signaling wiring and Article 770~~, ~~Parts I and V for optical fiber cabling shall be permitted where all of the following conditions~~ Part II and 722.120 are met:

- (1) Disconnecting means complying with 645.10 are provided.
- (2) A heating/ventilating/air-conditioning (HVAC) system is provided in one of the methods identified in the following:
 - (3) A separate HVAC system that is dedicated for information technology equipment use and is separated from other areas of occupancy.
 - (4) An HVAC system that serves other occupancies and meets all of the following:
 - (5) . Also serves the information technology equipment room
 - (6) . Provides fire/smoke dampers at the point of penetration of the room boundary.
 - (7) . Activates the damper operation upon initiation by smoke detector alarms by operation of the disconnecting means required by 645.10 . or by both

Informational Note No. 1: See NFPA 75-2024, *Standard for the Fire Protection of Information Technology Equipment*, Chapter 11, Section 11.1, 11.1.1, 11.1.2, and 11.1.3, for further information.

- (8) All information technology and communications equipment installed in the room, including measurement, control, and laboratory equipment, is listed.
- (9) The room is occupied by, and accessible to, only those personnel needed for the maintenance and functional operation of the installed information technology equipment.
- (10) The room is separated from other occupancies by fire-resistant-rated walls, floors, and ceilings with protected openings.

Informational Note No. 2: See NFPA 75-2024, *Standard for the Fire Protection of Information Technology Equipment*, Chapter 6, for further information on room construction requirements.

- (11) Only electrical equipment and wiring associated with the operation of the information technology room is installed in the room.

Informational Note No. 3: HVAC systems, communications systems, and monitoring systems such as telephone, fire alarm systems, security systems, water detection systems, and other related protective equipment are examples of equipment associated with the operation of the information technology room.

Statement of Problem and Substantiation for Public Comment

Article 725, Parts I and II is the 2023 NEC cover Class 2 & 3 circuits. Class 2 & 3 circuits are limited-energy circuits. The wiring methods in the First Draft are covered by Article 720, Part II, and section 722.120.

All the recommended changes are in the first line of the section. TerraView is responsible for the extra underlining.

Related Item

- FCR-228 • FCR-232

Submitter Information Verification

Submitter Full Name: Stanley Kaufman

Organization: CableSafe, Inc./OFS

Affiliation: Plastics Industry Association (PLASTICS)

Street Address:

City:

State:

Zip:

Submittal Date: Thu Aug 15 09:52:47 EDT 2024

Committee: NEC-P12



Public Comment No. 99-NFPA 70-2024 [Section No. 645.6(A)]

~~(A) Branch-Circuit Conductors Circuits .~~

~~The branch-circuit conductors supplying one or more units of information technology equipment shall have an ampacity not less than 125 percent of the total connected load . Information technology equipment shall be considered a continuous load .~~

Statement of Problem and Substantiation for Public Comment

The panel rejected my PI with the following strange statement "Conductor sizes are increased for many reasons based on the specific installation including the requirements of 310.15, voltage drop, number of conductors in a raceway, etc., but does not require the overcurrent protection value to be increased. This is a modification of 210.20(A) to protect the equipment yet protect the wiring as a continuous load."

Is it the panels intent that we size the conductors at 125% and we size the OCPD at 100%? If yes, then why are we sizing the wire at 125% and the OCPD at 100%?

Simply state that this load is considered a continuous load and then allow us to apply 210.19 for conductor sizing and 210.20 for OCPD rating.

Related Item

- 3168

Submitter Information Verification

Submitter Full Name: Mike Holt

Organization: Mike Holt Enterprises Inc

Street Address:

City:

State:

Zip:

Submittal Date: Tue Jul 16 18:42:49 EDT 2024

Committee: NEC-P12



Public Comment No. 1116-NFPA 70-2024 [Section No. 645.6(E)(2)]

(2) Installation Requirements for Power-Supply Cords, Data Cables, Interconnecting Cables, and Grounding Conductors Under a Raised Floor.

The following cords, cables, and conductors shall be permitted to be installed under a raised floor:

- (1) Power-supply cords of listed information technology equipment in accordance with 645.6(B).
- (2) Interconnecting cables enclosed in a raceway.
- (3) Equipment grounding conductors.
- (4) Where the air space under a raised floor is protected by an automatic fire suppression system, in addition to wiring installed in compliance with ~~794.722, 435.131 (A, B)~~ and Table 722.120, Types CL2R, CL3R, CL4R, OFNR, OFCR, CL2, CL3, CL4, OFN, OFC, and substitute cables, including CMP, OFNP, OFCP, CMR, CM, and CMG, OFNG and OFCG, installed in accordance with ~~794.135(D)~~ - 722.122, shall be permitted under raised floors.
- (5) Where the air space under a raised floor is not protected by an automatic fire suppression system, in addition to wiring installed in compliance with ~~794.722, 435.131 (A, B)~~ and Table 722.120, substitute cable ~~Type CMP,~~ Types CMP, OFNP and OFCP, installed in accordance with ~~794.135(D)~~ - 722.122, shall be permitted under raised floors.
- (6) Listed Type DP cable having adequate fire-resistant characteristics suitable for use under raised floors of an information technology equipment room.

Informational Note: See CSA C22.2 No. 0.3, *Test Methods for Electrical Wires and Cables*, CSA Vertical Flame Test-Cables in Cable Trays for one method of defining resistance to the spread of fire where the damage (char length) of the cable does not exceed 1.5 m (4 ft 11 in.) or "UL Flame Exposure, Vertical Flame Tray Test" in UL 1685-2015, ~~Standard for Safety for Vertical-Tray Fire-Propagation and Smoke-Release Test for Electrical and Optical-Fiber Cables~~. The smoke measurements in the test method are not applicable.

Statement of Problem and Substantiation for Public Comment

794.135(A), the cable application table is replaced by 722.131(B) and Table 722.120 in the First Draft. The cable application table includes optical fiber cables since the table includes all limited-energy cables.

794.135(D), cable substitutions, is replaced by 722.122 in the First Draft. The cable substitution rules include optical fiber cables since the table includes all limited-energy cables.

Related Item

- Global FCR-238 • Global FCR-221

Submitter Information Verification

Submitter Full Name: Stanley Kaufman

Organization: CableSafe, Inc./OFS

Affiliation: Plastics Industry Association (PLASTICS)

Street Address:

City:

State:

Zip:

Submittal Date: Thu Aug 15 10:12:21 EDT 2024

Committee: NEC-P12



Public Comment No. 654-NFPA 70-2024 [Section No. 645.6(E)(2)]

(2) Installation Requirements for Power-Supply Cords, Data Cables, Interconnecting Cables, and Grounding Conductors Under a Raised Floor.

The following cords, cables, and conductors shall be permitted to be installed under a raised floor:

- (1) Power-supply cords of listed information technology equipment in accordance with 645.6(B).
- (2) Interconnecting cables enclosed in a raceway.
- (3) Equipment grounding conductors.
- (4) Where the air space under a raised floor is protected by an automatic fire suppression system, in addition to wiring installed in compliance with 794.135(A), Types CL2R, CL3R, CL4R, CL2, CL3, CL4, and substitute cables, including CMP, CMR, CM, and CMG, installed in accordance with 794.135(D) shall be permitted under raised floors.
- (5) Where the air space under a raised floor is not protected by an automatic fire suppression system, in addition to wiring installed in compliance with 794.135(A), substitute cable Type CMP installed in accordance with 794.135(D) shall be permitted under raised floors.
- (6) Listed Type DP cable having adequate fire-resistant characteristics suitable for use under raised floors of an information technology equipment room.

Informational Note: See CSA C22.2 No. 0.3, *Test Methods for Electrical Wires and Cables*, CSA Vertical Flame Test-Cables in Cable Trays for one method of defining resistance to the spread of fire where the damage (char length) of the cable does not exceed 1.5 m (4 ft 11 in.) or "UL Flame Exposure, Vertical Flame Tray Test" in UL 1685-2015, *Standard for Safety for Vertical-Tray Fire-Propagation and Smoke-Release Test for Electrical and Optical-Fiber Cables*. The smoke measurements in the test method are not applicable.

Additional Proposed Changes

<u>File Name</u>	<u>Description</u>	<u>Approved</u>
CN_350.pdf		

Statement of Problem and Substantiation for Public Comment

NOTE: The following CC Note No. 350 appeared in the First Draft Report on First Revision No. 8538.

CMP 12 should consider the use of the words "adequate" and "suitable" in list item 6 relative to the NEC Style Manual Section 3.2.1. The terms "adequate" and "suitable" in list item 6 appear to be unenforceable, but the panel should consider that and revise if required.

Related Item

- First Revision No. 8538

Submitter Information Verification

Submitter Full Name: CC Notes

Organization: NEC Correlating Committee

Street Address:

City:

State:

Zip:

Submittal Date: Fri Aug 02 09:26:23 EDT 2024

Committee: NEC-P12



Correlating Committee Note No. 350-NFPA 70-2024 [Section No. 645.6(E)(2)]

Submitter Information Verification

Committee: NEC-AAC

Submittal Date: Fri May 10 08:31:57 EDT 2024

Committee Statement

Committee Statement: CMP 12 should consider the use of the words “adequate” and “suitable” in list item 6 relative to the NEC Style Manual Section 3.2.1. The terms “adequate” and “suitable” in list item 6 appear to be unenforceable, but the panel should consider that and revise if required.

First Revision No. 8538-NFPA 70-2024 [Section No. 645.5(E)(2)]

Ballot Results

✓ **This item has passed ballot**

12 Eligible Voters

1 Not Returned

11 Affirmative All

0 Affirmative with Comments

0 Negative with Comments

0 Abstention

Not Returned

McDaniel, Roger D.

Affirmative All

Ayer, Lawrence S.

Bowmer, Trevor N.

Hickman, Palmer L.

Holub, Richard A.

Jackson, Peter D.

Kendall, David H.

Manche, Alan

Osborne, Robert D.

Porter, Christine T.

Schultheis, Timothy James

Williams, David A.



Public Comment No. 1117-NFPA 70-2024 [Section No. 645.6(E)(3)]

~~(3) Installation Requirements for Optical Fiber Cables Under a Raised Floor.~~

~~The installation of optical fiber cables shall comply with either of the following:~~

- ~~(1) Where the air space under a raised floor is protected by an automatic fire suppression system, optical fiber cables installed in accordance with 770.113(C), Types OFNR, OFCR, OFNG, OFGG, OFN, and OFG shall be permitted under raised floors.~~
- ~~(2) Where the air space under a raised floor is not protected by an automatic fire suppression system, only optical fiber cables installed in accordance with 770.113(C) shall be permitted under raised floors.~~

Statement of Problem and Substantiation for Public Comment

Optical fiber cables are limited-energy cables and are included in the installation rules in Articles 720 and 722.

Related Item

- FCR-221 • FCR-238

Submitter Information Verification

Submitter Full Name: Stanley Kaufman

Organization: CableSafe, Inc./OFS

Affiliation: Plastics Industry Association (PLASTICS)

Street Address:

City:

State:

Zip:

Submittal Date: Thu Aug 15 10:39:29 EDT 2024

Committee: NEC-P12



Public Comment No. 1141-NFPA 70-2024 [Section No. 645.10(B)]

(B) Critical Operations Data Systems.

Remote disconnecting controls shall not be required for critical operations data systems when all of the following conditions are met:

- (1) An approved procedure has been established and maintained for removing power and air movement within the room or zone.
- (2) Qualified personnel are continuously available to advise emergency responders and to instruct them of disconnecting methods.
- (3) A smoke-sensing fire detection system is in place.

Informational Note: See *NFPA 72-2025, National Fire Alarm and Signaling Code*, for further information.

- (4) An approved fire suppression system suitable for the application is in place.
- (5) Cables installed under a raised floor, other than branch-circuit wiring, and power cords are installed in compliance with 645.6(E)(2) or 645.6(E)(3), or in compliance with Table 645.10(B).

Table 645.10(B) Cables, Cable Routing Assemblies and Communications Raceways, Installed Under Raised Floors

~~Communications wires and cables, cable routing assemblies, and communications raceways. Coaxial CATV and radio distribution cables~~

<u>Cable Type</u>	<u>Applicable Sections</u>
Branch circuits under raised floors	645.6(E)(1)
Supply cords of listed information technology equipment	645.6(E)(2)(1), 300.25(C)
Class 2 and Class 3 remote control and Class 4 Limited-energy cables in other spaces used for environmental air (plenums)	Table 722.435(B)
Optical fiber cable in other spaces used for environmental air (plenums)	770.113(C) and Table 770.154(a)
120 and 722.131(B)	
<u>Cable routing assemblies</u> in other spaces used for environmental air (plenums)	800 Table 723.413(C) and Tables 800.154(a); <u>10(a) and 723.40(B)</u> 800.154(b), and 800.154(c)
<u>Communications raceways</u> in other spaces used for environmental air (plenums)	800 Table 723.413 10 (C b) and Table 800 723 .454 40 (a B)

Statement of Problem and Substantiation for Public Comment

Table 645.10(B) includes Class 2, 3 & 4 cables, optical fiber cables, communications cables and CATV-type coaxial cables. Since these cables are all limited-energy cables, the recommended text for Table 645.10(B) can be simplified.

Cable routing assemblies and communications raceways are being moved to new Article 723.

Related Public Comments for This Document

<u>Related Comment</u>	<u>Relationship</u>
Public Comment No. 52-NFPA 70-2024 [New Article after 722]	
<u>Related Item</u>	
• FCR-238 • FCR-221	

Submitter Information Verification

Submitter Full Name: Stanley Kaufman
Organization: CableSafe, Inc./OFS
Affiliation: Plastics Industry Association (PLASTICS)
Street Address:
City:
State:
Zip:
Submittal Date: Fri Aug 16 00:53:22 EDT 2024
Committee: NEC-P12



Public Comment No. 1485-NFPA 70-2024 [Section No. 645.10(B)]

(B) Critical Operations Data Systems.

Remote disconnecting controls shall not be required for critical operations data systems when all of the following conditions are met:

- (1) An approved procedure has been established and maintained for removing power and air movement within the room or zone.
- (2) Qualified personnel are continuously available to advise emergency responders and to instruct them of disconnecting methods.
- (3) A smoke-sensing fire detection system is in place.

Informational Note: See *NFPA 72-2025, National Fire Alarm and Signaling Code*, for further information.

- (4) An approved fire suppression system suitable for the application is in place.
- (5) Cables installed under a raised floor, other than branch-circuit wiring, and power cords are installed in compliance with 645.6(E)(2) or 645.6(E)(3), or in compliance with Table 645.10(B).

Table 645.10(B) Cables Installed Under Raised Floors

<u>Cable Type</u>	<u>Applicable Sections</u>
Branch circuits under raised floors	645.6(E)(1)
Supply cords of listed information technology equipment	645.6(E)(2)(1), 300.25(C)
PLTC, Class 2 and Class 3 remote control and Class 4 cables in other spaces used for environmental air (plenums)	722.135(B)
Optical fiber cable in other spaces used for environmental air (plenums)	770.113(C) and Table 770.154(a)
Communications wires and cables, cable routing assemblies, and communications raceways in other spaces used for environmental air (plenums)	800.113(C) and Tables 800.154(a), 800.154(b), and 800.154(c)
Coaxial CATV and radio distribution cables in other spaces used for environmental air (plenums)	800.113(C) and Table 800.154(a)

Statement of Problem and Substantiation for Public Comment

The panel removed PLTC type cables with substantiation or discussion.

Related Item

- FR8547

Submitter Information Verification

Submitter Full Name: Joel Goergen
Organization: Cisco Systems, Inc.
Affiliation: Cisco Systems, Inc.
Street Address:
City:
State:
Zip:
Submittal Date: Fri Aug 23 14:34:25 EDT 2024
Committee: NEC-P12



Public Comment No. 1778-NFPA 70-2024 [Section No. 645.16]

645.16 Marking.

Each unit of an information technology system supplied by a branch circuit shall be provided with a manufacturer's nameplate, which shall also include the input power requirements for voltage, frequency, and maximum rated load in amperes.

[Informational Note: See UL 62368-1, Audio/Video, Information and Communication Technology Equipment — Part 1: Safety Requirements, for information on product markings.](#)

Statement of Problem and Substantiation for Public Comment

Product marking and labeling requirements are primarily governed by end-product standards. Extensive Information and Communication Technology Equipment product markings and labeling requirements are written in UL 62368-1. The end-product standard mandates that manufacturers provide detailed instructions, warnings, and markings on their devices, ensuring users are aware of potential risks and proper usage within a product's established electrical rating. By following the UL 62368-1 standard, Information and Communication Technology Equipment manufacturers ensure that their products adhere to the stringent product safety marking and labeling requirements.

Related Item

- PI 2481-NFPA 70-2023

Submitter Information Verification

Submitter Full Name: Joseph Prisco

Organization: IBM

Affiliation: Information Technology Industry Council

Street Address:

City:

State:

Zip:

Submittal Date: Tue Aug 27 10:33:25 EDT 2024

Committee: NEC-P12



Public Comment No. 1103-NFPA 70-2024 [Section No. 646.4(A)]

(A) Spread of Fire or Products of Combustion.

Sections 300.23, ~~770.26~~, and ~~800.26~~ 720.26-21 shall apply to penetrations of a fire-resistant room boundary, if provided.

Statement of Problem and Substantiation for Public Comment

Sections 770.26 and 800.26 are deleted in the First Draft report. Spread of Fire for limited-energy cables is in 720.21.

Related Public Comments for This Document

<u>Related Comment</u>	<u>Relationship</u>
Public Comment No. 1102-NFPA 70-2024 [Section No. 645.4(A)]	
Public Comment No. 1102-NFPA 70-2024 [Section No. 645.4(A)]	

Related Item

- FCR-228 • FCR-232

Submitter Information Verification

Submitter Full Name: Stanley Kaufman
Organization: CableSafe, Inc./OFS
Affiliation: Plastics Industry Association (PLASTICS)
Street Address:
City:
State:
Zip:
Submittal Date: Thu Aug 15 03:08:07 EDT 2024
Committee: NEC-P12



Public Comment No. 1105-NFPA 70-2024 [Section No. 646.4(B)]

(B) Wiring and Cabling in Other Spaces Used for Environmental Air (Plenums).

The following sections and tables shall apply to wiring and cabling in other spaces used for environmental air (plenums) within a modular data center space:

- (1) Wiring methods: 300.25(C)(1)
~~760.53~~
- (2) ~~Class 2, Class 3, and Class 4 Limited-energy~~ cables: ~~794~~ 722 . ~~435(A)~~
Fire alarm systems:
- (3) 131(B)
~~(2)~~
- (4) and Table
~~794~~
- (5) 722 .
~~320~~ **Optical fiber**
- (6) 120
- (7) Non-power-limited fire alarm cables:
~~770~~
- (8) 760 .
~~443~~
- (9) 53 (
~~E~~
- (10) B)
~~and Table 800.154(a)~~
- (11) Communications circuits: 800.113(C) and Table 800.154(a)
- (12) CATV and radio distribution systems: 800.113(C) and Table 800.154(a)
- (13) 20

Informational Note: Environmentally controlled working spaces, aisles, and equipment areas in an MDC are not considered a plenum.

Statement of Problem and Substantiation for Public Comment

Most of the cables in this section are limited-energy cables. These cables have one set of installation rules in 722.131(B) and Table 722.120.

Since power-limited fire alarm cable are limited-energy cables, non-power-limited fire alarm cables need reference in this section, 760.53(B)(2).

Related Public Comments for This Document

Related Comment

Relationship

Public Comment No. 1104-NFPA 70-2024 [Section No. 645.4(B)]

Public Comment No. 1104-NFPA 70-2024 [Section No. 645.4(B)]

Related Item

- FCR-228 • FCR-232

Submitter Information Verification

Submitter Full Name: Stanley Kaufman

Organization: CableSafe, Inc./OFS

Affiliation: Plastics Industry Association (PLASTICS)

Street Address:

City:

State:

Zip:

Submittal Date: Thu Aug 15 06:12:59 EDT 2024

Committee: NEC-P12



Public Comment No. 1486-NFPA 70-2024 [Section No. 646.4(B)]

(B) Wiring and Cabling in Other Spaces Used for Environmental Air (Plenums).

The following sections and tables shall apply to wiring and cabling in other spaces used for environmental air (plenums) within a modular data center space:

- (1) Wiring methods: 300.25(C)(1)
- (2) PLTC, Class 2, Class 3, and Class 4 cables: 794.135(A)
- (3) Fire alarm systems: 760.53(B)(2) and Table 794.320
- (4) Optical fiber cables: 770.113(C) and Table 800.154(a)
- (5) Communications circuits: 800.113(C) and Table 800.154(a)
- (6) CATV and radio distribution systems: 800.113(C) and Table 800.154(a)

Informational Note: Environmentally controlled working spaces, aisles, and equipment areas in an MDC are not considered a plenum.

Statement of Problem and Substantiation for Public Comment

The panel removed PLTC type cable without any substantiation or discussion.

Related Item

- FR8566

Submitter Information Verification

Submitter Full Name: Joel Goergen

Organization: Cisco Systems, Inc.

Affiliation: Cisco Systems, Inc.

Street Address:

City:

State:

Zip:

Submittal Date: Fri Aug 23 14:42:16 EDT 2024

Committee: NEC-P12



Public Comment No. 1111-NFPA 70-2024 [Section No. 646.4(E)]

(E).

~~Fire Alarm Equipment: Article 760, Parts I, II, and III shall apply to fire alarm systems, cables, and equipment installed in an MDC, where provided. Only fire alarm cables listed in~~

Limited-Energy Cables. Limited-energy cables in an MDC shall be listed in accordance with 722.2, and installed in accordance with 722.131 and Table 722.120.

(F) Fire Alarm Cables and Equipment. Power-limited fire alarm cables in an MDC room shall be listed and installed in accordance with 645.4(E). Non-power-limited fire alarm circuits in an information technology room shall be installed in accordance with Article 760, Part

~~IV and listed fire alarm equipment shall be permitted to be installed in an MDC~~

~~II. Power-limited fire alarm circuits in an information technology room shall be installed in accordance with Article 760, Part III.~~

Statement of Problem and Substantiation for Public Comment

Since power-limited fire alarm cables are limited-energy cables, and non-power-limited fire alarm cables are not limited-energy cables, the recommended text divides 646.4(E) into two sections, (E) which covers all limited-energy cables, and new (F) that covers non-power-limited fire alarm circuits (including non-power-limited fire alarm cables).

Related Public Comments for This Document

Related Comment

[Public Comment No. 1106-NFPA 70-2024 \[Section No. 645.4\(E\)\]](#)

[Public Comment No. 1106-NFPA 70-2024 \[Section No. 645.4\(E\)\]](#)

Relationship

Related Item

- FCR-232 • FCR-228

Submitter Information Verification

Submitter Full Name: Stanley Kaufman

Organization: CableSafe, Inc./OFS

Affiliation: Plastics Industry Association (PLASTICS)

Street Address:

City:

State:

Zip:

Submittal Date: Thu Aug 15 08:13:07 EDT 2024

Committee: NEC-P12



(
F
G).

Cable Routing Assemblies and Communications

Wires, Cables,
Raceways

~~and Equipment Sections 800.110, 800.113, and 800.154 shall apply to cable
Cable routing assemblies and communications raceways~~

~~Article 800, Parts I, II, III, and IV and Article 805, Parts I, III, and IV shall apply to communications wires, cables, and equipment installed
in an MDC~~

~~Only communications wires and cables
shall be listed in accordance with~~

~~800.170, cable routing assemblies and communications raceways listed
Article 723, Part II, and installed in accordance with~~

~~800.102, and communications equipment
Article 723, Part III.~~

(H) Communications Equipment. Communications equipment in an MDC shall be listed in accordance with

800
720.

~~174 shall be permitted to be installed in an MDC. Informational Note: See Article 400 for a definition of communications equipment
This Article shall apply to the powering of communications equipment in an information technology equipment room.~~

Statement of Problem and Substantiation for Public Comment

The First Draft Report includes cable routing assemblies and communications raceways in Article 722. They are outside the scope of Article 722, since Article 722 only covers cables. We have submitted PC 52 to create Article 723 which covers cable routing assemblies and communications raceways exclusively.

The requirements for listing communications equipment have been moved to Article 720.

Related Public Comments for This Document

Related Comment

Relationship

Public Comment No. 1109-NFPA 70-2024 [Section No. 645.4(F)]

Public Comment No. 1109-NFPA 70-2024 [Section No. 645.4(E)]

Related Item

• FCR-228 • FCR-232

Submitter Information Verification

Submitter Full Name: Stanley Kaufman

Organization: CableSafe, Inc./OFS

Affiliation: Plastics Industry Association (PLASTICS)

Street Address:

City:

State:

Zip:

Submittal Date: Thu Aug 15 09:01:22 EDT 2024

Committee: NEC-P12



Public Comment No. 1114-NFPA 70-2024 [Section No. 646.4(G)]

~~(G) Community Antenna Television and Radio Distribution Systems Cables and Equipment.~~

~~Article 800 , Parts I, II, III, and IV and Article 820 , Parts I and V shall apply to community antenna television and radio distribution systems equipment installed in an MDC. Only community antenna television and radio distribution coaxial cables listed in accordance with 800.179 and listed CATV equipment shall be permitted to be installed in an MDC.~~

Statement of Problem and Substantiation for Public Comment

CATV equipment is communications equipment that are covered under revised 646.4(H).

Related Public Comments for This Document

<u>Related Comment</u>	<u>Relationship</u>
<u>Public Comment No. 1113-NFPA 70-2024 [Sections 645.4(G), 645.4(H)]</u>	
<u>Public Comment No. 1113-NFPA 70-2024 [Sections 645.4(G), 645.4(H)]</u>	

Related Item

- FCR-228 • FCR-232

Submitter Information Verification

Submitter Full Name: Stanley Kaufman
Organization: CableSafe, Inc./OFS
Affiliation: Plastics Industry Association (PLASTICS)
Street Address:
City:
State:
Zip:
Submittal Date: Thu Aug 15 09:21:42 EDT 2024
Committee: NEC-P12



Public Comment No. 1142-NFPA 70-2024 [Section No. 646.4(K)]

(K) Wiring Methods and Materials.

Wiring methods and materials shall comply with the following:

- (1) Unless modified elsewhere in this article, wiring methods and materials for power distribution shall comply with Chapter 3. Wiring shall be suitable for its use and installation and shall be listed and labeled.

Exception: This requirement shall not apply to wiring that is part of listed and labeled equipment.

- (2) The following wiring methods shall not be permitted:

- (3) Integrated gas spacer cable: Type IGS (Article 326).
- (4) Concealed knob-and-tube wiring (Article 394).
- (5) Messenger-supported wiring (Article 396).
- (6) Open wiring on insulators (Article 398).
- (7) Outdoor overhead conductors over 600 volts (Article 395).

- (8) Wiring in areas under a raised floor that are constructed and used for ventilation as described in 645.6(E) shall be permitted to use the wiring methods described in 645.6(E) if the conditions of 645.5 are met.

- (9) Installation of ~~wiring for remote control, signaling, and power-limited circuits~~ limited-energy cables shall comply with 722.120 and Article 725 722, Part I and H.

- (10) ~~Installation of optical fiber cables shall comply with Article 770, Part V.~~

- (11) Alternate wiring methods as permitted by Article 645 shall be permitted for MDCs, provided that all of the conditions of 645.5 are met.

Statement of Problem and Substantiation for Public Comment

Class 2 and 3 power-limited cables, and optical fiber cables are limited-energy cables.

Related Item

- Global FCR-238

Submitter Information Verification

Submitter Full Name: Stanley Kaufman

Organization: CableSafe, Inc./OFS

Affiliation: Plastics Industry Association (PLASTICS)

Street Address:

City:

State:

Zip:

Submittal Date: Fri Aug 16 04:56:04 EDT 2024

Committee: NEC-P12



Public Comment No. 655-NFPA 70-2024 [Section No. 646.21(C)]

(C) Power Transformers.

Power transformers that supply power only to the MDC shall be permitted to be installed in the MDC equipment enclosure. Only dry-type transformers shall be permitted to be installed in the MDC equipment enclosure. Such transformers shall be installed in accordance with Article 450, Parts I, II, and III.

Additional Proposed Changes

<u>File Name</u>	<u>Description</u>	<u>Approved</u>
CN_351.pdf		

Statement of Problem and Substantiation for Public Comment

NOTE: The following CC Note No. 351 appeared in the First Draft Report on First Revision No. 8582.

CMP 12 should revise the section in accordance with NEC® Style Manual Section 4.1.4. In accordance with 90.3 and Section 4.1.4, the panel should consider eliminating the reference to the transformer installation requirements or refer to the specific installation sections without referencing the entire article.

Related Item

- First Revision No. 8582

Submitter Information Verification

Submitter Full Name: CC Notes

Organization: NEC Correlating Committee

Street Address:

City:

State:

Zip:

Submittal Date: Fri Aug 02 09:27:58 EDT 2024

Committee: NEC-P12



Correlating Committee Note No. 351-NFPA 70-2024 [Section No. 646.21(C)]

Submitter Information Verification

Committee: NEC-AAC

Submittal Date: Fri May 10 08:33:49 EDT 2024

Committee Statement

Committee Statement: CMP 12 should revise the section in accordance with NEC® Style Manual Section 4.1.4. In accordance with 90.3 and Section 4.1.4, the panel should consider eliminating the reference to the transformer installation requirements or refer to the specific installation sections without referencing the entire article.

First Revision No. 8582-NFPA 70-2024 [Section No. 646.11(C)]

Ballot Results

✓ **This item has passed ballot**

12 Eligible Voters

1 Not Returned

11 Affirmative All

0 Affirmative with Comments

0 Negative with Comments

0 Abstention

Not Returned

McDaniel, Roger D.

Affirmative All

Ayer, Lawrence S.

Bowmer, Trevor N.

Hickman, Palmer L.

Holub, Richard A.

Jackson, Peter D.

Kendall, David H.

Manche, Alan

Osborne, Robert D.

Porter, Christine T.

Schultheis, Timothy James

Williams, David A.



Public Comment No. 1143-NFPA 70-2024 [Section No. 650.4(B)]

~~(B)– Optical Fiber Cable . . Limited-Energy Cables .~~

~~Installations of optical fiber limited-energy_ cables shall be in accordance with Article 770 , Parts I and V: 722.131 and Table 722.120.~~

Statement of Problem and Substantiation for Public Comment

Article 770 will be deleted. Optical fiber cables are limited-energy cables.

Related Item

- Global FCR-238

Submitter Information Verification

Submitter Full Name: Stanley Kaufman

Organization: CableSafe, Inc./OFS

Affiliation: Plastics Industry Association (PLASTICS)

Street Address:

City:

State:

Zip:

Submittal Date: Fri Aug 16 05:18:58 EDT 2024

Committee: NEC-P12



Public Comment No. 656-NFPA 70-2024 [Section No. 660.3]

660.3 Reconditioned Equipment.

All equipment for new X-ray installations and all used or reconditioned X-ray equipment moved to and reinstalled at a new location shall be of a permitted type.

Additional Proposed Changes

<u>File Name</u>	<u>Description</u>	<u>Approved</u>
CN_352.pdf		

Statement of Problem and Substantiation for Public Comment

NOTE: The following CC Note No. 352 appeared in the First Draft Report on First Revision No. 8752.

CMP 12 should consider the use of the ambiguous term "permitted" in this section in regard to NEC Style Manual Section 3.1.2. While "permitted" is not a defined term, it is often used in relation to seeking permission from the AHJ to install specific equipment or permitted alternate methods and that doesn't appear to be what the committee intends in this section. If the intent is to refer to the types allowed in 660.23, a reference to that section, here, would potentially clear this up. Additionally, the Correlating Committee directs CMP-12 to review the language used for reconditioned equipment based on the Correlating Committee Usability Task Group's recommended format:

XXX.3 Reconditioned Equipment

(A) Permitted to be Installed

The installation of the following reconditioned equipment shall be permitted.

(1) List item one

(2) List item two

(B) Not Permitted to be Installed

The installation of the following reconditioned equipment shall not be permitted.

(1) List item one

(2) List item two

(if only a single permitted use)

XXX.3 Reconditioned Equipment

The installation of reconditioned (item) shall be permitted.

(if only a single not permitted use)

XXX.3 Reconditioned Equipment

The installation of reconditioned (item) shall not be permitted.

Related Item

- First Revision No. 8752

Submitter Information Verification

Submitter Full Name: CC Notes

Organization: NEC Correlating Committee

Street Address:

City:

State:

Zip:

Submittal Date: Fri Aug 02 09:29:34 EDT 2024

Committee: NEC-P12



Correlating Committee Note No. 352-NFPA 70-2024 [Section No. 660.3]

Submitter Information Verification

Committee: NEC-AAC

Submittal Date: Fri May 10 09:05:03 EDT 2024

Committee Statement

Committee Statement: CMP 12 should consider the use of the ambiguous term “permitted” in this section in regard to NEC Style Manual Section 3.1.2. While “permitted” is not a defined term, it is often used in relation to seeking permission from the AHJ to install specific equipment or permitted alternate methods and that doesn’t appear to be what the committee intends in this section. If the intent is to refer to the types allowed in 660.23, a reference to that section, here, would potentially clear this up. Additionally, the Correlating Committee directs CMP-12 to review the language used for reconditioned equipment based on the Correlating Committee Usability Task Group’s recommended format:

XXX.3 Reconditioned Equipment

(A) Permitted to be Installed

The installation of the following reconditioned equipment shall be permitted.

(1) List item one

(2) List item two

(B) Not Permitted to be Installed

The installation of the following reconditioned equipment shall not be permitted.

(1) List item one

(2) List item two

(if only a single permitted use)

XXX.3 Reconditioned Equipment

The installation of reconditioned (item) shall be permitted.

(if only a single not permitted use)

XXX.3 Reconditioned Equipment

The installation of reconditioned (item) shall not be permitted.

First Revision No. 8752-NFPA 70-2024 [Section No. 660.10]

Ballot Results

✔ **This item has passed ballot**

12 Eligible Voters

1 Not Returned

11 Affirmative All

0 Affirmative with Comments

0 Negative with Comments

0 Abstention

Not Returned

McDaniel, Roger D.

Affirmative All

Ayer, Lawrence S.

Bowmer, Trevor N.

Hickman, Palmer L.

Holub, Richard A.

Jackson, Peter D.

Kendall, David H.

Manche, Alan

Osborne, Robert D.

Porter, Christine T.

Schultheis, Timothy James

Williams, David A.



Public Comment No. 658-NFPA 70-2024 [Section No. 660.35]

660.35 General.

Transformers and capacitors that are part of an X-ray equipment shall not be required to comply with 450.1 and 460.1.

Additional Proposed Changes

<u>File Name</u>	<u>Description</u>	<u>Approved</u>
CN_353.pdf		

Statement of Problem and Substantiation for Public Comment

NOTE: The following CC Note No. 353 appeared in the First Draft Report on First Revision No. 8751.

CMP 12 should revise this section in compliance with comply with NEC Style Manual Section 4.1.4, noting that references to entire articles are permitted where necessary for proper context. As an alternative the panel may also consider the approach used in FR-9059 on 517.76 by CMP15.

Related Item

- First Revision No. 8751

Submitter Information Verification

Submitter Full Name: CC Notes

Organization: NEC Correlating Committee

Street Address:

City:

State:

Zip:

Submittal Date: Fri Aug 02 09:31:41 EDT 2024

Committee: NEC-P12



Correlating Committee Note No. 353-NFPA 70-2024 [Section No. 660.35]

Submitter Information Verification

Committee: NEC-AAC

Submittal Date: Fri May 10 09:07:04 EDT 2024

Committee Statement

Committee Statement: CMP 12 should revise this section in compliance with comply with NEC Style Manual Section 4.1.4, noting that references to entire articles are permitted where necessary for proper context. As an alternative the panel may also consider the approach used in FR-9059 on 517.76 by CMP15.

First Revision No. 8751-NFPA 70-2024 [Section No. 660.35]

Ballot Results

✓ **This item has passed ballot**

12 Eligible Voters

1 Not Returned

11 Affirmative All

0 Affirmative with Comments

0 Negative with Comments

0 Abstention

Not Returned

McDaniel, Roger D.

Affirmative All

Ayer, Lawrence S.

Bowmer, Trevor N.

Hickman, Palmer L.

Holub, Richard A.

Jackson, Peter D.

Kendall, David H.

Manche, Alan

Osborne, Robert D.

Porter, Christine T.

Schultheis, Timothy James

Williams, David A.



Public Comment No. 660-NFPA 70-2024 [Section No. 668.4]

668.4 Other Articles.

(A) Lighting, Ventilating, Material Handling.

Chapters 1 through 4 shall apply to services, feeders, branch circuits, and apparatus for supplying lighting, ventilating, material handling, and the like that are outside the electrolytic cell line working zone.

(B) Systems Not Electrically Connected.

Those elements of a cell line power-supply system that are not electrically connected to the cell supply system, such as the primary winding of a two-winding transformer, the motor of a motor-generator set, feeders, branch circuits, disconnecting means, motor controllers, and overload protective equipment, shall be required to comply with all applicable sections of this code.

(C) Electrolytic Cell Lines.

Electrolytic cell lines shall comply with the provisions of Chapters 1 through 4 except as amended in 668.4(C)(1) through 668.4(C)(4).

(1) Conductors.

The electrolytic cell line conductors shall not be required to comply with 110.1, 120.1, 210.1, 215.1, and 225.1. See 668.12.

(2) Overcurrent Protection.

Overcurrent protection of electrolytic cell dc process power circuits shall not be required to comply with the requirements of 240.1.

(3) Grounding.

Except as required by this article, equipment located or used within the electrolytic cell line working zone or associated with the cell line dc power circuits shall not be required to comply with 250.1.

(4) Working Zone.

The electrolytic cells, cell line attachments, and the wiring of auxiliary equipment and devices within the cell line working zone shall not be required to comply with 110.1, 120.1, 210.1, 215.1, and 225.1. See 668.30.

Informational Note: See 668.15 for equipment, apparatus, and structural component grounding.

Additional Proposed Changes

<u>File Name</u>	<u>Description</u>	<u>Approved</u>
CN_354.pdf		

Statement of Problem and Substantiation for Public Comment

NOTE: The following CC Note No. 354 appeared in the First Draft Report on First Revision No. 8758.

CMP 12 should revise this section in compliance with NEC Style Manual Section 4.1.4. In this instance, for clarity, it may be preferable to refer to the entire article "for context" as opposed to referring the user to the scope sections of the referenced articles because those sections do not contain requirements and are an improper reference.

Related Item

- First Revision No. 8758

Submitter Information Verification

Submitter Full Name: CC Notes
Organization: NEC Correlating Committee
Street Address:
City:
State:
Zip:
Submittal Date: Fri Aug 02 09:38:55 EDT 2024
Committee: NEC-P12



Correlating Committee Note No. 354-NFPA 70-2024 [Section No. 668.4]

Submitter Information Verification

Committee: NEC-AAC

Submittal Date: Fri May 10 09:08:55 EDT 2024

Committee Statement

Committee Statement: CMP 12 should revise this section in compliance with NEC Style Manual Section 4.1.4. In this instance, for clarity, it may be preferable to refer to the entire article “for context” as opposed to referring the user to the scope sections of the referenced articles because those sections do not contain requirements and are an improper reference.

First Revision No. 8758-NFPA 70-2024 [Section No. 668.3]

Ballot Results

✓ **This item has passed ballot**

12 Eligible Voters

1 Not Returned

11 Affirmative All

0 Affirmative with Comments

0 Negative with Comments

0 Abstention

Not Returned

McDaniel, Roger D.

Affirmative All

Ayer, Lawrence S.

Bowmer, Trevor N.

Hickman, Palmer L.

Holub, Richard A.

Jackson, Peter D.

Kendall, David H.

Manche, Alan

Osborne, Robert D.

Porter, Christine T.

Schultheis, Timothy James

Williams, David A.



Public Comment No. 1623-NFPA 70-2024 [New Part after III.]

625.45 GFCI Protection For Personnel

Ground-fault circuit-interrupter protection for personnel shall be provided for all receptacles.

The ground-fault circuit-interrupter indication and reset shall be installed in a readily accessible location.

Ground-fault circuit-interrupter receptacles and breakers shall be listed, rated and marked for bidirectional use.

Statement of Problem and Substantiation for Public Comment

It appears that the necessity to establish requirements, testing procedures and labelling for bidirectional GFCI equipment has been overlooked, which results in a roadblock for bidirectional vehicles and devices.

GFCI breakers, receptacles and equipment rated and labeled for bidirectional use must be available on the market for purchase before actual systems can be installed in the field.

Related Item

- Global FR 9093 • FR-7788

Submitter Information Verification

Submitter Full Name: Achim Ginsberg-Klemmt

Organization: GismoPower LLC

Affiliation: Gismo Power LLC

Street Address:

City:

State:

Zip:

Submittal Date: Sun Aug 25 10:50:32 EDT 2024

Committee: NEC-P12



Sections 627.17(B), 627.17(C)

(B) Output Cables to ESV.

The output cable to the ESV shall comply with all of the following:

(1) Output cables to ESVs shall be

either

one of the following

(a) Listed Types EV, EVJ, EVE, EVJE, EVT, or EVJT flexible cables as specified in Table 400.4

(b) Integral parts of listed ESVSE

~~(c) Overall Cord and Output Cable Length.~~

~~Overall~~ The overall usable length of output cable to the ESV shall not exceed 7 15.5 m- 25 m (25 ft 50 ft) unless equipped with a cable management system that is part of the listed ESVSE.

~~(1) Portable Equipment:~~

~~For portable ESVSE, cord-exposed usable length shall be measured from the face of attachment plugs to the face of ESV connectors.~~

~~(2) Fastened-in-Place:~~

~~Where ESVSE is fastened-in-place, the usable length of~~

~~The usable length of output cables to ESVs shall be measured from the cable exits of~~

~~exit of the ESVSE to the face of ESV connectors.~~

Where wireless power transfer equipment (WPT) is fastened-in-place, the output cables to the primary pads shall be measured from the cable exits of the control boxes to the cable inlets at the primary pads.

Statement of Problem and Substantiation for Public Comment

The requirements for output cable length were based on the general idea of how long a cable needed to be so that regardless of how a car was parked the cable would be able to reach the inlet. Further, since the output cable was in an area where the general public was going to be moving about, there was a concern with trip hazards. In the case of Article 627, the Code is addressing other equipment such as agricultural tractors, construction equipment, industrial trucks, aircraft, ferries, etc. All of these instances are more aligned with qualified personnel rather than the general public. Additionally, the prohibition on the output cable length is overly restrictive in that these vehicles may need longer output cables to be used within their prescribed use cases. Two examples: 1) For aircraft that cannot be moved around as easily as other vehicles, the output cable needs to be able to reach the inlet on the aircraft while dealing with things like wingspan and overhead connection points. 2) For charging ferries, the vessel may be located at the end of a pier and not necessarily adjacent to the charger which may be installed further from the water's edge. In all cases, cable management can be included for cable lengths under 50 feet at the manufacturer's discretion, the same as it can be included for EV charging today. However, Article 625 required the use of cable management when over 25 feet and it is suggested by this comment that we increase this limit to 50 feet for Article 627.

Editorially, this change also integrates item (C) into item (B) to provide a parallel structure to item (A) and to clarify the concept of output cable length. As a note, item (D) would need to be revised to (C).

Related Item

- FR9039

Submitter Information Verification

Submitter Full Name: Joseph Bablo

Organization: UL Solutions

Street Address:

City:

State:

Zip:

Submittal Date: Tue Jul 30 15:10:22 EDT 2024

Committee: NEC-P12

Copyright Assignment

I, Joseph Bablo, hereby irrevocably grant and assign to the National Fire Protection Association (NFPA) all and full rights in copyright in this Public Comment (including both the Proposed Change and the Statement of Problem and Substantiation). I understand and intend that I acquire no rights, including rights as a joint author, in any publication of the NFPA in which this Public Comment in this or another similar or derivative form is used. I hereby warrant that I am the author of this Public Comment and that I have full power and authority to enter into this copyright assignment.

By checking this box I affirm that I am Joseph Bablo, and I agree to be legally bound by the above Copyright Assignment and the terms and conditions contained therein. I understand and intend that, by checking this box, I am creating an electronic signature that will, upon my submission of this form, have the same legal force and effect as a handwritten signature



Public Comment No. 1319-NFPA 70-2024 [Sections 625.44(A), 625.44(B)]

Sections 625.44(A), 625.44(B)

(A) Portable Equipment.

Portable equipment shall be connected to the premises wiring system by one or more of the following methods:

- (1) A nonlocking, 2-pole, 3-wire grounding-type receptacle outlet rated at 125 volts or 250 volts, single phase in accordance with one of the following:

- (2) 15 or 20 amperes

- (3) 30 or 50 amperes

~~listed and marked for EVSE and WPTE use~~

a.

- (4) A nonlocking, 3-pole, 4-wire grounding-type receptacle outlet rated at 125/250 volts, single phase in accordance with one of the following:

- (5) 15 or 20 amperes

- (6) 30, 50, or 60 amperes

~~listed and marked for EVSE and WPTE use~~

a.

- (7) A nonlocking, 2-pole, 3-wire grounding-type receptacle outlet rated at 277 volts, single phase in accordance with one of the following:

- (8) 15 or 20 amperes

- (9) 30 or 50 amperes

~~listed and marked for EVSE and WPTE use~~

a.

- (10) A nonlocking, 2-pole, 3-wire grounding-type receptacle outlet rated at 60 volts dc maximum, 15 or 20 amperes

(B) Fastened-in-Place Equipment.

Equipment that is fastened-in-place shall be connected to the premises wiring system by one of the following methods:

- (1) A nonlocking, 2-pole, 3-wire grounding-type receptacle outlet rated 125 volts or 250 volts, single phase in accordance with one of the following:

(2) 15 or 20 amperes

(3) 30 or 50 amperes

~~listed and marked for EVSE and WPTE use~~

a.

- (4) A nonlocking, 3-pole, 4-wire grounding-type receptacle outlet rated 250 volts, three phase in accordance with one of the following:

(5) 15 or 20 amperes

(6) 30, 50, or 60 amperes

~~listed and marked for EVSE and WPTE use~~

a.

- (7) A nonlocking, 3-pole, 4-wire grounding-type receptacle outlet rated 125/250 volts, single phase in accordance with one of the following:

(8) 15 or 20 amperes

(9) 30, 50, or 60 amperes

~~listed and marked for EVSE and WPTE use~~

a.

- (10) A nonlocking, 2-pole, 3-wire grounding-type receptacle outlet rated 277 volts, single phase in accordance with one of the following:

(11) 15 or 20 amperes

(12) 30, 50, or 60 amperes

~~listed and marked for EVSE and WPTE use~~

a.

- (13) A nonlocking, 3-pole, 4-wire grounding-type receptacle outlet rated at 120/208 volts, three phase in accordance with one of the following:

(14) 15 or 20 amperes

(15) 30, 50, or 60 amperes

~~listed and marked for EVSE and WPTE use~~

a.

- (16) A nonlocking, 2-pole, 3-wire grounding-type receptacle outlet rated 60 volts dc maximum, 15 or 20 amperes

The current drawn by EVSE is no different than the current drawn by other appliances, and as such there is no reason to impose a different set of requirement for EVSE/EV when no such requirement exists for other household appliances. Putting this requirement in NEC, creates unnecessary burden to consumer as EV/EVSE are being unfairly penalized, increasing the barrier to entry to adopt green and new technology. Deficiencies on receptacles (if any) should be addressed in the product standard level for receptacles, so that benefits of improved reliability and performance of receptacles can be shared across all applications and industries.

Related Item

- PI 2522

Submitter Information Verification

Submitter Full Name: Indra Wiryadinata

Organization: Tesla

Street Address:

City:

State:

Zip:

Submittal Date: Tue Aug 20 15:16:31 EDT 2024

Committee: NEC-P12

Copyright Assignment

I, Indra Wiryadinata, hereby irrevocably grant and assign to the National Fire Protection Association (NFPA) all and full rights in copyright in this Public Comment (including both the Proposed Change and the Statement of Problem and Substantiation). I understand and intend that I acquire no rights, including rights as a joint author, in any publication of the NFPA in which this Public Comment in this or another similar or derivative form is used. I hereby warrant that I am the author of this Public Comment and that I have full power and authority to enter into this copyright assignment.

By checking this box I affirm that I am Indra Wiryadinata, and I agree to be legally bound by the above Copyright Assignment and the terms and conditions contained therein. I understand and intend that, by checking this box, I am creating an electronic signature that will, upon my submission of this form, have the same legal force and effect as a handwritten signature



Sections 625.44(B), 625.44(C)

(B)– ~~Fastened-in-Place Equipment~~ Hand Fastened .

Equipment that is hand fastened ~~in-place~~ shall be connected to the premises wiring system by one of the following methods:

- (1) A nonlocking, 2-pole, 3-wire grounding-type receptacle outlet rated 125 volts or 250 volts, single phase in accordance with one of the following:
 - (2) 15 or 20 amperes
 - (3) 30 or 50 amperes listed and marked for EVSE and WPTE use
- (4) A nonlocking, 3-pole, 4-wire grounding-type receptacle outlet rated 250 volts, three phase in accordance with one of the following:
 - (5) 15 or 20 amperes
 - (6) 30, 50, or 60 amperes listed and marked for EVSE and WPTE use
- (7) A nonlocking, 3-pole, 4-wire grounding-type receptacle outlet rated 125/250 volts, single phase in accordance with one of the following:
 - (8) 15 or 20 amperes
 - (9) 30, 50, or 60 amperes listed and marked for EVSE and WPTE use
- (10) A nonlocking, 2-pole, 3-wire grounding-type receptacle outlet rated 277 volts, single phase in accordance with one of the following:
 - (11) 15 or 20 amperes
 - (12) 30, 50, or 60 amperes listed and marked for EVSE and WPTE use
- (13) A nonlocking, 3-pole, 4-wire grounding-type receptacle outlet rated at 120/208 volts, three phase in accordance with one of the following:
 - (14) 15 or 20 amperes
 - (15) 30, 50, or 60 amperes listed and marked for EVSE and WPTE use
- (16) A nonlocking, 2-pole, 3-wire grounding-type receptacle outlet rated 60 volts dc maximum, 15 or 20 amperes

(C)– ~~Fixed-in-Place~~ Securely Fastened in Place Equipment.

All other EVSE and WPTE shall be permanently wired and fixed-in-place to the supporting surface.

Additional Proposed Changes

<u>File Name</u>	<u>Description</u>	<u>Approved</u>
Substation_for_Comments_for_Fixed-Fastened.docx	Substantiation and impact on other Code areas	✓

Statement of Problem and Substantiation for Public Comment

Public inputs regarding the CMP-12 definitions for “Fixed-in-place” and “Fastened-in-place” by two prominent Code trainers and commentators (PI-2460 by Mike Holt and PI-4230 and 4231 by Jeffrey Simpson) clearly display the confusion that exists in the public with these definitions (their Public Inputs were resolved due to their errant substantiation based on their misunderstanding). Though technically correct as is, these minor changes will simplify and clarify the Code by modifying the one term and using a consistent phrase already in use throughout the Code.

Background

“Fastened in place” is used in the Code 58 times as follows”

Chapter 1: In addition to the CMP-12 definition it is used in the “Appliance” definition.

Chapter 2: 17 times, implies fixed and specifies (fixed) in a few places

Chapter 3: 19 times, prefaced with “securely” to make the phrase “securely fastened in place”; 20 times overall

Chapter 4: 1 time prefaced with “securely”; 2 times overall

Chapter 5: 2 times prefaced with “securely”; 6 times overall

Chapter 6: 5 times prefaced with “securely”; 10 times overall; the other 5 times in 625 (see below)

Chapter 8: 1 time prefaced with “securely”

The use of the phrase “securely fastened in place” is essentially the same definition that article 625 is applying to the term “fixed-in-place”.

“Fixed in place” is used only 1 time in the CMP-12 portion of the Code and two other times in total – 1 in Chapter 5 and 1 in Chapter 7. A term that is only used once does not require a definition since that same definition can be written in place of the term at the point of use. However, it is proposed to use the same phrase that is used 28 times in the Code to mean the same thing (securely fastened in place).

Related Public Comments for This Document

<u>Related Comment</u>	<u>Relationship</u>
<u>Public Comment No. 2033-NFPA 70-2024 [Definition: Fastened-in-Place (as applied to electric vehic...]</u>	
<u>Public Comment No. 2040-NFPA 70-2024 [Definition: Fixed-in-Place (as applied to electric vehicle ...]</u>	
<u>Public Comment No. 2045-NFPA 70-2024 [Section No. 625.17]</u>	

Related Item

- PI-2460, 4230, 4231

Submitter Information Verification

Submitter Full Name: Karl Cunningham

Organization: Self Employed

Street Address:

City:

State:

Zip:

Submittal Date: Wed Aug 28 16:52:54 EDT 2024

Committee: NEC-P12

Copyright Assignment

I, Karl Cunningham, hereby irrevocably grant and assign to the National Fire Protection Association (NFPA) all and full rights in copyright in this Public Comment (including both the Proposed Change and the Statement of Problem and Substantiation). I understand and intend that I acquire no rights, including rights as a joint author, in any publication of the NFPA in which this Public Comment in this or another similar or derivative form is used. I hereby warrant that I am the author of this Public Comment and that I have full power and authority to enter into this copyright assignment.

By checking this box I affirm that I am Karl Cunningham, and I agree to be legally bound by the above Copyright Assignment and the terms and conditions contained therein. I understand and intend that, by checking this box, I am creating an electronic signature that will, upon my submission of this form, have the same legal force and effect as a handwritten signature

Substantiation for NEC 70 Comments for Fixed-in-place, Fastened-in-place

Public inputs regarding the CMP-12 definitions for “Fixed-in-place” and “Fastened-in-place” by two prominent Code trainers and commentators (PI-2460 by Mike Holt and PI-4230 and 4231 by Jeffrey Simpson) clearly display the confusion that exists in the public with these definitions (their Public Inputs were resolved due to their errant substantiation based on their misunderstanding). Though technically correct as is, these minor changes will simplify and clarify the Code by modifying the one term and using a consistent phrase already in use throughout the Code.

Background

“Fastened in place” is used in the Code 58 times as follows”

Chapter 1: In addition to the CMP-12 definition it is used in the “Appliance” definition.

Chapter 2: 17 times, implies fixed and specifies (fixed) in a few places

Chapter 3: 19 times, prefaced with “securely” to make the phrase “securely fastened in place”; 20 times overall

Chapter 4: 1 time prefaced with “securely”; 2 times overall

Chapter 5: 2 times prefaced with “securely”; 6 times overall

Chapter 6: 5 times prefaced with “securely”; 10 times overall; the other 5 times in 625 (see below)

Chapter 8: 1 time prefaced with “securely”

The use of the phrase “securely fastened in place” is essentially the same definition that article 625 is applying to the term “fixed-in-place”.

“Fixed in place” is used only 1 time in the CMP-12 portion of the Code and two other times in total – 1 in Chapter 5 and 1 in Chapter 7. A term that is only used once does not require a definition since that same definition can be written in place of the term at the point of use. However, it is proposed to use the same phrase that is used 28 times in the Code to mean the same thing (securely fastened in place).

Proposal to delete the highlighted/strikethrough words and add in the **green** words as follows:

Fixed-in-Place.

Mounting means of equipment using fasteners that require a tool for removal. (625) (CMP-12)

Delete

Fastened-in-Place.

Mounting means of equipment in which the fastening means are specifically designed to permit removal without the use of a tool. (625) (CMP-12)

Change definition to “Hand Fastened”

625.17(A) Power-Supply Cord.

The cable for cord-connected electric vehicle supply equipment (EVSE) shall comply with all of the following:

1. (1)

Be any of the types specified in [625.17\(B\)\(1\)](#) or hard service cord, junior hard service cord, or portable power cable types in accordance with [Table 400.4](#). Hard service cord, junior hard service cord, or portable power cable types shall be listed, as applicable, for exposure to oil and damp and wet locations.

2. (2)

Have an ampacity as specified in [Table 400.5\(A\)\(1\)](#) or, for 8 AWG and larger, in the 60°C (140°F) columns of [Table 400.5\(A\)\(2\)](#).

3. (3)

Have an overall length as specified in either of the following:

1. a.

When the interrupting device of the personnel protection system specified in [625.22](#) is located within the enclosure of the supply equipment or charging system, the power-supply cord shall be not more than the length indicated in (i) or (ii):

1. (i)

For portable equipment in accordance with [625.44\(A\)](#), the power-supply cord shall be not more than 300 mm (12 in.) long.

2. (ii)

For ~~fastened-in-place~~ hand fastened equipment in accordance with [625.44\(B\)](#), the power-supply cord shall be not more than 1.8 m (6 ft) long and the equipment shall be installed at a height that prevents the power-supply cord from contacting the floor when it is connected to the proper receptacle.

2. b.

When the interrupting device of the personnel protection system specified in [625.22](#) is located at the attachment plug, or within the first 300 mm (12 in.) of the power-supply cord, the overall cord length shall be not greater than 4.6 m (15 ft).

625.17(B) Output Cable to Electric Vehicles.

The output cable to electric vehicles shall be one of the following:

1. (1)

Listed Type EV, EVJ, EVE, EVJE, EVT, or EVJT flexible cable as specified in [Table 400.4](#)

2. (2)

An integral part of listed electric vehicle supply equipment
Informational Note No. 1: See UL 2594-2016, *Standard for Electric Vehicle Supply Equipment*, for information on conductive electric vehicle supply equipment.

Informational Note No. 2: See UL 2202-2009, *Standard for Electric Vehicle (EV) Charging System Equipment*, for information on conductive electric vehicle charging equipment.

625.17(C) Overall Cord and Cable Length.

The overall usable length shall not exceed 7.5 m (25 ft) unless equipped with a cable management system that is part of the listed electric vehicle supply equipment.

625.17(C)(1) Portable Equipment.

For portable EVSE, the cord-exposed usable length shall be measured from the face of the attachment plug to the face of the electric vehicle connector.

625.17(C)(2) Fastened-in-Place. Hand Fastened

Where the EVSE is ~~fastened-in-place~~, **hand fastened** the usable length of the output cable to the electric vehicle shall be measured from the cable exit of the electric vehicle supply equipment to the face of the electric vehicle connector.

Where the wireless power transfer equipment (WPTE) is fastened-in-place, the output cable to the primary pad shall be measured from the cable exit of the control box to the cable inlet at the primary pad.

625.44(B) Fastened-in-Place Hand Fastened Equipment.

Equipment that is fastened-in-place shall be connected to the premises wiring system by one of the following methods:

1. (1)

A nonlocking, 2-pole, 3-wire grounding-type receptacle outlet rated 125 volts or 250 volts, single phase, up to 50 amperes

2. (2)

A nonlocking, 3-pole, 4-wire grounding-type receptacle outlet rated 250 volts, three phase, up to 50 amperes

3. (3)

A nonlocking, 3-pole, 4-wire grounding-type receptacle outlet rated 125/250 volts, single phase, 30, 50, or 60 amperes

4. (4)

A nonlocking, 2-pole, 3-wire grounding-type receptacle outlet rated 60 volts dc maximum, 15 or 20 amperes

625.44(C) Fixed-in-Place Securely Fastened in Place Equipment.

All other EVSE and WPTE shall be permanently wired and ~~fixed-in-place~~ securely fastened in place to the supporting surface.



Public Comment No. 327-NFPA 70-2024 [Global Input]

CMP 1 has deleted the definition for “In Sight From”, and the requirements that were part of that definition are now located in 110.29. This global Correlating Committee Note directs all CMP’s to review occurrences of the phrase “in sight from”, “within sight from”, and “within sight” and consider whether references to 110.29 or 110.39 should be included.

Additional Proposed Changes

<u>File Name</u>	<u>Description</u>	<u>Approved</u>
CN_26.pdf	NEC_CN26	✓

Statement of Problem and Substantiation for Public Comment

NOTE: The following CC Note No. 26 appeared in the First Draft Report on First Revision No. 9187.

CMP 1 has deleted the definition for “In Sight From”, and the requirements that were part of that definition are now located in 110.29. This global Correlating Committee Note directs all CMP’s to review occurrences of the phrase “in sight from”, “within sight from”, and “within sight” and consider whether references to 110.29 or 110.39 should be included.

Related Item

- First Revision No. 9187

Submitter Information Verification

Submitter Full Name: CC Notes

Organization: NEC Correlating Committee

Street Address:

City:

State:

Zip:

Submittal Date: Mon Jul 29 17:05:29 EDT 2024

Committee: NEC-P01

Copyright Assignment

I, CC Notes, hereby irrevocably grant and assign to the National Fire Protection Association (NFPA) all and full rights in copyright in this Public Comment (including both the Proposed Change and the Statement of Problem and Substantiation). I understand and intend that I acquire no rights, including rights as a joint author, in any publication of the NFPA in which this Public Comment in this or another similar or derivative form is used. I hereby warrant that I am the author of this Public Comment and that I have full power and authority to enter into this copyright assignment.

By checking this box I affirm that I am CC Notes, and I agree to be legally bound by the above Copyright Assignment and the terms and conditions contained therein. I understand and intend that, by checking this box, I am creating an electronic signature that will, upon my submission of this form, have the same legal force and effect as a handwritten signature



Correlating Committee Note No. 26-NFPA 70-2024 [Global Input]

Submitter Information Verification

Committee: NEC-AAC

Submittal Date: Tue May 07 14:23:07 EDT 2024

Committee Statement and Meeting Notes

Committee Statement: CMP 1 has deleted the definition for “In Sight From”, and the requirements that were part of that definition are now located in 110.29. This global Correlating Committee Note directs all CMP’s to review occurrences of the phrase “in sight from”, “within sight from”, and “within sight” and consider whether references to 110.29 or 110.39 should be included.

First Revision No. 9187-NFPA 70-2024 [Section No. 225.41]

Ballot Results

✔ **This item has passed ballot**

12 Eligible Voters

1 Not Returned

11 Affirmative All

0 Affirmative with Comments

0 Negative with Comments

0 Abstention

Not Returned

McDaniel, Roger D.

Affirmative All

Ayer, Lawrence S.

Bowmer, Trevor N.

Hickman, Palmer L.

Holub, Richard A.

Jackson, Peter D.

Kendall, David H.

Manche, Alan

Osborne, Robert D.

Porter, Christine T.

Schultheis, Timothy James

Williams, David A.



Public Comment No. 443-NFPA 70-2024 [Global Input]

The Correlating Committee directs all Code-Making Panels to verify cross-references to Article 200 are accurate due to the renumbering of the article.

Additional Proposed Changes

<u>File Name</u>	<u>Description</u>	<u>Approved</u>
CN_84.pdf		✓

Statement of Problem and Substantiation for Public Comment

NOTE: The following CC Note No. 84 appeared in the First Draft Report.

The Correlating Committee directs all Code-Making Panels to verify cross-references to Article 200 are accurate due to the renumbering of the article.

Related Item

- Correlating Committee Note No. 84

Submitter Information Verification

Submitter Full Name: CC Notes

Organization: NEC Correlating Committee

Street Address:

City:

State:

Zip:

Submittal Date: Tue Jul 30 17:35:49 EDT 2024

Committee: NEC-P05

Copyright Assignment

I, CC Notes, hereby irrevocably grant and assign to the National Fire Protection Association (NFPA) all and full rights in copyright in this Public Comment (including both the Proposed Change and the Statement of Problem and Substantiation). I understand and intend that I acquire no rights, including rights as a joint author, in any publication of the NFPA in which this Public Comment in this or another similar or derivative form is used. I hereby warrant that I am the author of this Public Comment and that I have full power and authority to enter into this copyright assignment.

By checking this box I affirm that I am CC Notes, and I agree to be legally bound by the above Copyright Assignment and the terms and conditions contained therein. I understand and intend that, by checking this box, I am creating an electronic signature that will, upon my submission of this form, have the same legal force and effect as a handwritten signature



Correlating Committee Note No. 84-NFPA 70-2024 [Global Input]

Submitter Information Verification

Committee: NEC-AAC

Submittal Date: Wed May 08 08:49:53 EDT 2024

Committee Statement

Committee Statement: The Correlating Committee directs all Code-Making Panels to verify cross-references to Article 200 are accurate due to the renumbering of the article.

Ballot Results

✓ **This item has passed ballot**

12 Eligible Voters

1 Not Returned

11 Affirmative All

0 Affirmative with Comments

0 Negative with Comments

0 Abstention

Not Returned

McDaniel, Roger D.

Affirmative All

Ayer, Lawrence S.

Bowmer, Trevor N.

Hickman, Palmer L.

Holub, Richard A.

Jackson, Peter D.

Kendall, David H.

Manche, Alan

Osborne, Robert D.

Porter, Christine T.

Schultheis, Timothy James

Williams, David A.



Public Comment No. 504-NFPA 70-2024 [Global Input]

The Correlating Committee directs the CMPs to review the revision of the title of Article 406 (Wiring Devices) and the new definition for the term "wiring device" in Article 100 for correlation of existing terminology using the newly define term in their articles.

Additional Proposed Changes

<u>File Name</u>	<u>Description</u>	<u>Approved</u>
CN_157.pdf		✓

Statement of Problem and Substantiation for Public Comment

NOTE: The following CC Note No. 157 appeared in the First Draft Report on First Revision No. 7965.

The Correlating Committee directs the CMPs to review the revision of the title of Article 406 (Wiring Devices) and the new definition for the term "wiring device" in Article 100 for correlation of existing terminology using the newly define term in their articles.

Related Item

- First Revision No. 7965

Submitter Information Verification

Submitter Full Name: CC Notes

Organization: NEC Correlating Committee

Street Address:

City:

State:

Zip:

Submittal Date: Tue Jul 30 22:29:14 EDT 2024

Committee: NEC-P18

Copyright Assignment

I, CC Notes, hereby irrevocably grant and assign to the National Fire Protection Association (NFPA) all and full rights in copyright in this Public Comment (including both the Proposed Change and the Statement of Problem and Substantiation). I understand and intend that I acquire no rights, including rights as a joint author, in any publication of the NFPA in which this Public Comment in this or another similar or derivative form is used. I hereby warrant that I am the author of this Public Comment and that I have full power and authority to enter into this copyright assignment.

By checking this box I affirm that I am CC Notes, and I agree to be legally bound by the above Copyright Assignment and the terms and conditions contained therein. I understand and intend that, by checking this box, I am creating an electronic signature that will, upon my submission of this form, have the same legal force and effect as a handwritten signature



Correlating Committee Note No. 157-NFPA 70-2024 [Global Input]

Submitter Information Verification

Committee: NEC-AAC

Submittal Date: Thu May 09 08:59:03 EDT 2024

Committee Statement and Meeting Notes

Committee Statement: The Correlating Committee directs the CMPs to review the revision of the title of Article 406 (Wiring Devices) and the new definition for the term "wiring device" in Article 100 for correlation of existing terminology using the newly define term in their articles.

First Revision No. 7965-NFPA 70-2024 [New Definition after Definition: Wireways, Nonmetallic..(No...)]

Ballot Results

✔ **This item has passed ballot**

12 Eligible Voters

1 Not Returned

11 Affirmative All

0 Affirmative with Comments

0 Negative with Comments

0 Abstention

Not Returned

McDaniel, Roger D.

Affirmative All

Ayer, Lawrence S.

Bowmer, Trevor N.

Hickman, Palmer L.

Holub, Richard A.

Jackson, Peter D.

Kendall, David H.

Manche, Alan

Osborne, Robert D.

Porter, Christine T.

Schultheis, Timothy James

Williams, David A.



Public Comment No. 527-NFPA 70-2024 [Global Input]

The CMPs are directed to review references to Article 220 in the articles under their purview and make necessary revisions based on Article 220 being relocated to Article 120.

Additional Proposed Changes

<u>File Name</u>	<u>Description</u>	<u>Approved</u>
CN_212.pdf		✓

Statement of Problem and Substantiation for Public Comment

NOTE: The following CC Note No. 212 appeared in the First Draft Report.

The CMPs are directed to review references to Article 220 in the articles under their purview and make necessary revisions based on Article 220 being relocated to Article 120.

Related Item

- Correlating Committee Note No. 212

Submitter Information Verification

Submitter Full Name: CC Notes

Organization: NEC Correlating Committee

Street Address:

City:

State:

Zip:

Submittal Date: Tue Jul 30 23:08:41 EDT 2024

Committee: NEC-P02

Copyright Assignment

I, CC Notes, hereby irrevocably grant and assign to the National Fire Protection Association (NFPA) all and full rights in copyright in this Public Comment (including both the Proposed Change and the Statement of Problem and Substantiation). I understand and intend that I acquire no rights, including rights as a joint author, in any publication of the NFPA in which this Public Comment in this or another similar or derivative form is used. I hereby warrant that I am the author of this Public Comment and that I have full power and authority to enter into this copyright assignment.

By checking this box I affirm that I am CC Notes, and I agree to be legally bound by the above Copyright Assignment and the terms and conditions contained therein. I understand and intend that, by checking this box, I am creating an electronic signature that will, upon my submission of this form, have the same legal force and effect as a handwritten signature



Correlating Committee Note No. 212-NFPA 70-2024 [Global Input]

Submitter Information Verification

Committee: NEC-AAC

Submittal Date: Thu May 09 11:53:08 EDT 2024

Committee Statement and Meeting Notes

Committee Statement: The CMPs are directed to review references to Article 220 in the articles under their purview and make necessary revisions based on Article 220 being relocated to Article 120.

Ballot Results

✔ This item has passed ballot

12 Eligible Voters

1 Not Returned

11 Affirmative All

0 Affirmative with Comments

0 Negative with Comments

0 Abstention

Not Returned

McDaniel, Roger D.

Affirmative All

Ayer, Lawrence S.

Bowmer, Trevor N.

Hickman, Palmer L.

Holub, Richard A.

Jackson, Peter D.

Kendall, David H.

Manche, Alan

Osborne, Robert D.

Porter, Christine T.

Schultheis, Timothy James

Williams, David A.



Public Comment No. 542-NFPA 70-2024 [Global Input]

The Correlating Committee directs the CMPs to review all references to requirements in Chapters 7 & 8 for accuracy in light of the relocation of requirements occurring in the First Draft.

Additional Proposed Changes

<u>File Name</u>	<u>Description</u>	<u>Approved</u>
CN_401.pdf		✓

Statement of Problem and Substantiation for Public Comment

NOTE: The following CC Note No. 401 appeared in the First Draft Report.

The Correlating Committee directs the CMPs to review all references to requirements in Chapters 7 & 8 for accuracy in light of the relocation of requirements occurring in the First Draft.

Related Item

- Correlating Committee Note No. 401

Submitter Information Verification

Submitter Full Name: CC Notes

Organization: NEC Correlating Committee

Street Address:

City:

State:

Zip:

Submittal Date: Tue Jul 30 23:39:04 EDT 2024

Committee: NEC-P03

Copyright Assignment

I, CC Notes, hereby irrevocably grant and assign to the National Fire Protection Association (NFPA) all and full rights in copyright in this Public Comment (including both the Proposed Change and the Statement of Problem and Substantiation). I understand and intend that I acquire no rights, including rights as a joint author, in any publication of the NFPA in which this Public Comment in this or another similar or derivative form is used. I hereby warrant that I am the author of this Public Comment and that I have full power and authority to enter into this copyright assignment.

By checking this box I affirm that I am CC Notes, and I agree to be legally bound by the above Copyright Assignment and the terms and conditions contained therein. I understand and intend that, by checking this box, I am creating an electronic signature that will, upon my submission of this form, have the same legal force and effect as a handwritten signature



Correlating Committee Note No. 401-NFPA 70-2024 [Global Input]

Submitter Information Verification

Committee: NEC-AAC

Submittal Date: Fri May 10 12:35:51 EDT 2024

Committee Statement

Committee Statement: The Correlating Committee directs the CMPs to review all references to requirements in Chapters 7 & 8 for accuracy in light of the relocation of requirements occurring in the First Draft.

Ballot Results

✔ **This item has passed ballot**

12 Eligible Voters

1 Not Returned

11 Affirmative All

0 Affirmative with Comments

0 Negative with Comments

0 Abstention

Not Returned

McDaniel, Roger D.

Affirmative All

Ayer, Lawrence S.

Bowmer, Trevor N.

Hickman, Palmer L.

Holub, Richard A.

Jackson, Peter D.

Kendall, David H.

Manche, Alan

Osborne, Robert D.

Porter, Christine T.

Schultheis, Timothy James

Williams, David A.

