



Public Input No. 50-NFPA 24-2019 [Global Input]

A public Input was submitted to move Figure A.10.19.1 from the body to the annex. If accepted, all language that reads Figure 10.10.1 needs to be changed to read Figure A.10.10.1

Statement of Problem and Substantiation for Public Input

A public Input was submitted to move Figure A.10.19.1 from the body to the annex. If accepted, all language that reads Figure 10.10.1 needs to be changed to read Figure A.10.10.1

Related Public Inputs for This Document

Related Input	Relationship
Public Input No. 48-NFPA 24-2019 [Section No. 10.10.1]	related
Public Input No. 49-NFPA 24-2019 [New Section after A.10.9.3]	related

Submitter Information Verification

Submitter Full Name: Roland Asp
Organization: National Fire Sprinkler Association
Affiliation: On behalf of NFSA Engineering and Standards Committee
Street Address:
City:
State:
Zip:
Submission Date: Fri Jun 07 10:09:29 EDT 2019
Committee:

Committee Statement

Resolution: [FR-29-NFPA 24-2019](#)

Statement: The current test certificates have not been updated for many cycles. It appears that the current code requires contractors to use the form found in figure 10.10.1 without modification. Several companies have moved to digital forms which are easier to read and edit on a screen and allow for digital signatures. Many of these companies have made modifications to their digital forms to provide various improvements to the current certificate:

1. Added important information found in the acceptance chapter that is not found on the form (for example, backfilling of trench)
2. Reconfiguring the form based on the party responsible for the data entry. The form requires input that is typically supplied by multiple parties. (for example, the designer, the project manager, and the fitter). The portion to be supplied by each party is scattered throughout the document making it difficult to fill out correctly. Usually this form is partially filled out by the designer (material and design criteria), then the project manager provides additional information (welding, O&Ms, etc.), and then the fitter supplies the testing results.
3. Reconfiguring the form based on the natural sequence of the testing. Most systems are hydrostatically tested weeks before the alarms are installed and ready for testing. Most system are trip and alarm tested before owner training is scheduled. Following the natural order makes the form more self-documenting, provides better instruction, and ensures completion.

4. Modify for multiple signatures. There is only one spot on this form for a signature even though multiple activities are covered by these forms which often take place by different people at separate occasions. Often, AHJs and GCs require paperwork to be submitted after each activity, resulting in the submission of incomplete forms, which looks bad and can expose one to liability.

5. A smart, digital form or software package could collect just the relevant information needed for acceptance, reducing the number of blank fields and duplicate entries. Modern software can not only make completing the form easier, but can also distribute the completed form for digital signatures, and archive the certificates in cloud storage.

6. Add additional instruction or legal language. The one-size-fits-all form prevents contractors from including important instruction or legal verbiage that may protect them from future legal action.

By moving this form to the annex, contractors will have the ability to tailor a form to be pertinent to the particular project. (This may be a Task Group project to update and modernize these forms.

This concept if accepted needs to be correlated with NFPA 24 and NFPA 13. Similar PI have been submitted to NFPA 13



Public Input No. 37-NFPA 24-2019 [Section No. 1.1]

GLOBAL: In the Committee Scope statement, in the Table of Contents and throughout Annex C and D, revise all references (10 locations) for “fire flow testing” to “water flow testing”.

1.1 Scope.

1.1.1

This standard shall cover the minimum requirements for the installation of private fire service mains and their appurtenances, which include supplying the following:

- (1) Automatic sprinkler systems
- (2) Open sprinkler systems
- (3) Water spray fixed systems
- (4) Foam systems
- (5) Private hydrants
- (6) Monitor nozzles or standpipe systems with reference to water supplies
- (7) Hose houses

1.1.2

This standard shall apply to combined service mains intended to carry water for fire service and other uses.

1.1.3

This standard shall not apply to the following situations:

- (1) Mains under the control of a water utility
- (2) Mains providing fire protection and/or domestic water that are privately owned but are operated as a water utility

1.1.4

This standard shall not apply to underground mains serving sprinkler systems designed and installed in accordance with NFPA 13R that are less than 4 in. (100 mm) in nominal diameter.

1.1.5

This standard shall not apply to underground mains serving sprinkler systems designed and installed in accordance with NFPA 13D.

Statement of Problem and Substantiation for Public Input

This proposal offered to clarify that the text in NFPA 24 does delve into the subject of “fire flow”. The fire flow required for actual fire fighting purposes is the subject matter for building and fire codes. It is not within the scope of NFPA 24, which is primarily an installation standard.

When NFPA 24 currently speaks to “fire flow testing” the subject matter is really just providing a method for conducting water flow tests for fire protection purposes, be it to determine the available water supply for things such as a sprinkler system design or a NFPA 25 requirement, or to actually confirm the water supply relative to a facility’s fire flow requirement.

Submitter Information Verification

Submitter Full Name: Larry Keeping

Organization: PLC Fire Safety Solutions

Street Address:

City:

State:

Zip:

Submittal Date: Sun Mar 17 14:32:10 EDT 2019

Committee: AUT-PRI

Committee Statement

Resolution: FR-2-NFPA 24-2019 is based on PI 37 with the exception of revising committee scope. PI 42 is part of the FR PI 2 is also part of the FR 2.

Statement: This proposal offered to clarify that the text in NFPA 24 does delve into the subject of "fire flow". The fire flow required for actual fire fighting purposes is the subject matter for building and fire codes. It is not within the scope of NFPA 24, which is primarily an installation standard.

When NFPA 24 currently speaks to "fire flow testing" the subject matter is really just providing a method for conducting water flow tests for fire protection purposes, be it to determine the available water supply for things such as a sprinkler system design or a NFPA 25 requirement, or to actually confirm the water supply relative to a facility's fire flow requirement.



Public Input No. 42-NFPA 24-2019 [Section No. 1.1.1]

1.1.1

This standard shall ~~cover the~~ provide the minimum requirements for the installation of private fire service mains and their appurtenances, which include supplying the following:

- (1) Automatic sprinkler systems
- (2) Open sprinkler systems
- (3) Water spray fixed systems
- (4) Foam systems
- (5) Private hydrants
- (6) Monitor nozzles or standpipe systems with reference to water supplies
- (7) Hose houses

Statement of Problem and Substantiation for Public Input

editorial in nature

Submitter Information Verification

Submitter Full Name: Robert Caputo
Organization: Fire & Life Safety America
Street Address:
City:
State:
Zip:
Submission Date: Thu Apr 18 15:44:58 EDT 2019
Committee: AUT-PRI

Committee Statement

Resolution: FR-2-NFPA 24-2019 is based on PI 37 with the exception of revising committee scope. PI 42 is part of the FR PI 2 is also part of the FR 2.

Statement: This proposal offered to clarify that the text in NFPA 24 does delve into the subject of "fire flow". The fire flow required for actual fire fighting purposes is the subject matter for building and fire codes. It is not within the scope of NFPA 24, which is primarily an installation standard.

When NFPA 24 currently speaks to "fire flow testing" the subject matter is really just providing a method for conducting water flow tests for fire protection purposes, be it to determine the available water supply for things such as a sprinkler system design or a NFPA 25 requirement, or to actually confirm the water supply relative to a facility's fire flow requirement.



Public Input No. 2-NFPA 24-2018 [Section No. 1.1.3]

1.1.3

This standard shall not apply to the following situations:

- (1) Mains under the control of a water utility
- (2) Mains providing fire protection and/or domestic water that are privately owned but are operated as a water utility
- (3) Dry fire hydrants utilized for drafting or mains connected to dry fire hydrants utilized for drafting

A.1.1.3 (3) The installation of dry fire hydrants is covered in NFPA 1142 Standard on Water Supplies for Suburban and Rural Fire Fighting.

Statement of Problem and Substantiation for Public Input

It does not appear that the standard is intended to cover dry hydrants utilized for drafting. These are covered under NFPA 1142. New annex test is also proposed to provide a pointer to the user on where to go for guidance on dry fire hydrants utilized for drafting purposes.

Submitter Information Verification

Submitter Full Name: Anthony Apfelbeck
Organization: Altamonte Springs Building/Fire Safety Division
Street Address:
City:
State:
Zip:
Submission Date: Fri Oct 12 13:07:15 EDT 2018
Committee: AUT-PRI

Committee Statement

Resolution: FR-2-NFPA 24-2019 is based on PI 37 with the exception of revising committee scope. PI 42 is part of the FR PI 2 is also part of the FR 2.

Statement: This proposal offered to clarify that the text in NFPA 24 does delve into the subject of "fire flow". The fire flow required for actual fire fighting purposes is the subject matter for building and fire codes. It is not within the scope of NFPA 24, which is primarily an installation standard.

When NFPA 24 currently speaks to "fire flow testing" the subject matter is really just providing a method for conducting water flow tests for fire protection purposes, be it to determine the available water supply for things such as a sprinkler system design or a NFPA 25 requirement, or to actually confirm the water supply relative to a facility's fire flow requirement.



Public Input No. 10-NFPA 24-2019 [Section No. 1.5]

1.5 Units.

1.5.1

Metric units of measurement in this standard shall be in accordance with the modernized metric system known as the International System of Units (SI). ~~Liter and bar units are not part of, but are recognized by, SI and are used commonly in international fire protection. These units are shown in~~

Delete existing Table 1.5.1

~~with conversion factors.~~

Table 1.5.1 Conversion Table for SI Units

Name of Unit	Unit Symbol	Conversion Factor
Liter	L	1 gal = 3.785 L
Liter per minute per square meter	(L/min)/m ²	1 gpm/ft ² = (40.746 L/min)/m ²
Cubic decimeter	dm ³	1 gal = 3.785 dm ³
Pascal	Pa	1 psi = 6894.757 Pa
Bar	bar	1 psi = 0.0689 bar
Bar	bar	1 bar = 10 ⁵ Pa

Note: For additional conversions and information, see ASTM SI10, *Standard for Use of the International System of Units (SI): The Modern Metric System*.

[1.5.1.1 Two units \(liter and bar\) are outside of but recognized by SI, are commonly used in international fire protection.](#)

[1.5.1.2 These units with conversion factors shall be used as listed in Table 1.5.1.](#)

1.5.2

If a value for a measurement given in this standard is followed by an equivalent value in other units, the first stated is to be regarded as the requirement. ~~A given equivalent value might be approximate.~~

1.5.3

SI units have been converted by multiplying the quantity by the conversion factor and then rounding the result to the appropriate number of significant digits.

Some dimensions used in this standard are exact and some are not. Nominal dimensions are often used, such as the dimensions used for pipe sizes. The metric equivalent shown in this standard might not be an exact conversion to the SI unit, but the nominal metric equivalent is typically used or a reasonably equivalent value or approximate conversion is used. It shall be acceptable to use the exact conversion or the conversions stated in the standard, even though they might not be exact.

Table 1.5.1 Conversion Table for SI Units

Quantity	Name of Unit	Unit Symbol	Conversion Factor
Length	meter	m	1 ft = 0.3048 m
Area	square meter	m ²	1 ft ² = 0.092903 m ²
Volume	cubic meter	m ³	1 ft ³ = 0.028317 m ³
Fluid Capacity	liter	L	1 gal. = 3.785 L
Flow	liter per minute	L/min	1 gpm = 3.785 L/min
Pressure	bar	bar	1 psi = 0.0689 bar
	kilopascal	kPa	1 psi = 6.894757 kPa
	Newton per square meter	N/m ²	1 lb _f /ft ² = 47.8800 N/m ²
Temperature	degrees Celsius	°C	1°F = 9/5 x C° + 32
Velocity	meter per second	m/s	1 fps = 0.3048 m/s
Force	Newton	N	1 lb _f = 4.448822 N
Stress	kilonewton per square meter	kN/m ²	1 lb _f /ft ² = 0.047880 kN/m ²
	megapascal	MPa	1 lb _f /in ² = 0.006895 MPA

Note: For additional conversions and information, see ASTM SI10, Standard for Use of the International System of Units (SI): The Modern Metric System.

Additional Proposed Changes

File Name	Description	Approved
Table_1_5_1.docx	Proposed New Table 1.5.1	

Statement of Problem and Substantiation for Public Input

This proposal is offered to better follow the Manual of Style and to provide the same information on metric conversions as is found in NFPA 13-2019.

The current Table 1.5.1 is of little value to users of NFPA 24, because some of the units such as those for “cubic decimeters” and “liter per minute per square meter” are not used in the standard and units such as the “Pascal” are seldom used, in lieu of larger units such as the “bar” or the “kilopascal”. The proposed table provides conversion factors for units which are actually used throughout the document.

Submitter Information Verification

Submitter Full Name: Larry Keeping
Organization: PLC Fire Safety Solutions
Street Address:
City:
State:
Zip:
Submittal Date: Sat Mar 16 21:22:11 EDT 2019
Committee: AUT-PRI

Committee Statement

Resolution: [FR-3-NFPA 24-2019](#)

Statement: This proposal is offered to better follow the Manual of Style and to provide the same information on metric conversions as is found in NFPA 13-2019.

The current Table 1.5.1 is of little value to users of NFPA 24, because some of the units such as those for “cubic decimeters” and “liter per minute per square meter” are not used in the standard and units such as the “Pascal” are seldom used, in lieu of larger units such as the “bar” or the “kilopascal”. The proposed table provides conversion factors for units which are actually used throughout the document.



Public Input No. 5-NFPA 24-2018 [Section No. 2.3]

2.3 Other Publications.

2.3.1 ASME Publications.

American Society of Mechanical Engineers, Two Park Avenue, New York, NY 10016-5990.

ASME B1.20.1, *Pipe Threads, General Purpose (Inch)*, 2013.

ASME B16.1, *Gray Iron Pipe Flanges and Flanged Fittings, Classes 12, 25, 125, and 250*, 2015.

ASME B16.3, *Malleable Iron Threaded Fittings, Classes 150 and 300*, 2014 201 6.

ASME B16.4, *Gray Iron Threaded Fittings, Classes 125 and 250*, 2014 201 6.

2.3.2 ASTM Publications.

ASTM International, 100 Barr Harbor Drive, P.O. Box C700, West Conshohocken, PA 19428-2959.

ASTM A53/A53M, *Standard Specification for Pipe, Steel, Black and Hot-Dipped, Zinc-Coated, Welded and Seamless*, 2012 201 8.

ASTM A135/A135M, *Standard Specification for Electric-Resistance-Welded Steel Pipe*, 2009- (, reapproved 2014) .

ASTM A312/312M, *Standard Specification for Seamless, Welded, and Heavily Cold Worked Austenitic Stainless Steel Pipes*, 2017.

ASTM A795/A795M, *Standard Specification for Black and Hot-Dipped Zinc-Coated (Galvanized) Welded and Seamless Steel Pipe for Fire Protection Use*, 2013.

ASTM B43, *Specification for Seamless Red Brass Pipe, Standard Sizes*, 2015.

ASTM B75/B75M, *Specification for Seamless Copper Tube*, 2011.

ASTM B88, *Specification for Seamless Copper Water Tube*, 2014 201 8.

ASTM B251/**B251M**, *Requirements for Wrought Seamless Copper and Copper-Alloy Tube*, 2010 201 7.

ASTM C136/136M, *Standard Test Method for Sieve Analysis of Fine and Coarse Aggregates*, 2014.

ASTM D2487, *Standard Practice for Classification of Soils for Engineering Purposes (Unified Soil Classification System)*, 2011 201 7.

ASTM SI10, *Standard for Use of the International System of Units (SI): The Modern Metric System*, 2010 201 6.

2.3.3 AWWA Publications.

American Water Works Association, 6666 West Quincy Avenue, Denver, CO 80235.

AWWA C104/A21.4, *Cement-Mortar Lining for Ductile-Iron Pipe and Fittings*, 2014 [201 6](#) .

AWWA C105/A21.5, *Polyethylene Encasement for Ductile-Iron Pipe Systems*, 2010.

AWWA C110/A21.10, *Ductile-Iron and Gray-Iron Fittings*, 2012.

AWWA C111/A21.11, *Rubber-Gasket Joints for Ductile-Iron Pressure Pipe and Fittings*, 2012 [201 7](#) .

AWWA C115/A21.15, *Flanged Ductile-Iron Pipe with Ductile-Iron or Gray-Iron Threaded Flanges*, 2011.

AWWA C150/A21.50, *Thickness Design of Ductile-Iron Pipe*, 2014.

AWWA C151/A21.51, *Ductile-Iron Pipe, Centrifugally Cast*, 2009 [20 17](#), [errata 2018](#) .

AWWA C153/A21.53, *Ductile-Iron Compact Fittings*, 2011.

AWWA C300, *Reinforced Concrete Pressure Pipe, Steel-Cylinder Type*, 2011 [201 6](#) .

AWWA C301, *Prestressed Concrete Pressure Pipe, Steel-Cylinder Type*, 2014.

AWWA C302, *Reinforced Concrete Pressure Pipe, Noncylinder Type*, 2011 [201 6](#) .

AWWA C303, *Reinforced Concrete Pressure Pipe, Bar-Wrapped, Steel-Cylinder Type*, 2008 [20 17](#) .

AWWA C600, *Installation of Ductile Iron Water Mains and Their Appurtenances*, 2010 [201 7](#) .

AWWA C602, *Cement-Mortar Lining of Water Pipe Lines in Place, 4 in. (100 mm) and Larger*, 2011 [201 7](#) .

AWWA C900, *Polyvinyl Chloride (PVC) Pressure Pipe and Fabricated Fittings, 4 in. Through 12 in Through 60 in . (100 mm Through 300 mm), for Water Transmission and Distribution* , 2007, Errata, 2008 Through [1,500 mm](#)), [2016](#) .

AWWA C905, *Polyvinyl Chloride (PVC) Pressure Pipe and Fabricated Fittings, 14 in. Through 48 in. (350 mm Through 1200 mm), for Water Transmission and Distribution*, 2010, Erratum, 2013.

AWWA C906, *Polyethylene (PE) Pressure Pipe and Fittings, 4 in. (100 mm) Through 63 in. (1575 mm [1650 mm](#)) for Waterworks*, 2015.

AWWA C909, *Molecularly Oriented Polyvinyl Chloride (PVCO) Pressure Pipe, 4 in. Through 24 in. (100 mm- Through 600 mm) , for Water, Wastewater, and Reclaimed Water Service* , 2009 [and Larger](#) , [2016](#) .

AWWA M23, *PVC Pipe — Design and Installation*, 2002.

AWWA M55, *PE Pipe — Design and Installation*, 2006.

2.3.4 Other Publications.

Merriam-Webster's Collegiate Dictionary, 11th edition, Merriam-Webster, Inc., Springfield, MA, 2003.

Statement of Problem and Substantiation for Public Input

Referenced current national consensus standard editions.

Submitter Information Verification

Submitter Full Name: Aaron Adamczyk
Organization: [Not Specified]
Street Address:
City:
State:
Zip:
Submission Date: Tue Oct 30 00:15:30 EDT 2018
Committee: AUT-PRI

Committee Statement

Resolution: [FR-4-NFPA 24-2019](#)

Statement: Referenced current national consensus standard editions.



Public Input No. 55-NFPA 24-2019 [New Section after 3.3.15]

3.3.16 System Working Pressure

The maximum anticipated static (nonflowing) or flowing pressure applied to fire protection system components exclusive of surge pressures and exclusive of pressure from the fire department connection.

Statement of Problem and Substantiation for Public Input

A definition of system working pressure is needed in this document.

Submitter Information Verification

Submitter Full Name: Peter Schwab

Organization: Wayne Automatic Fire Sprinkler

Street Address:

City:

State:

Zip:

Submission Date: Mon Jun 10 15:10:20 EDT 2019

Committee: AUT-PRI

Committee Statement

Resolution: [FR-5-NFPA 24-2019](#)

Statement: A definition of system working pressure is needed in this document.



Public Input No. 44-NFPA 24-2019 [Section No. 5.2]

5.2 Size of Fire Mains.

5.2.1 Private Fire Service Mains.

5.2.1.1 Hydraulic calculations shall show that the main is able to supply the total demand at the appropriate pressure.

5.2.1.2 For mains that supply fire hydrants, pipe size shall not be less than 6 in. (150 mm) nominal size.

5.2.2 Mains Not Supplying Hydrants.

For mains that do not supply hydrants, pipe sizes less than 6 in. (150 mm) nominal size shall be permitted to be used subject to the following restrictions:

- (1) The main shall supply only the following types of systems:
 - (2) Automatic sprinkler systems
 - (3) Open sprinkler systems
 - (4) Water spray fixed systems
 - (5) Foam systems
 - (6) Standpipe systems
- (7) Hydraulic calculations shall show that the main is able to supply the total demand at the appropriate pressure.
- (8) Systems that are not hydraulically calculated shall have a main at least as large as the riser.

Statement of Problem and Substantiation for Public Input

The current language in section 5.2.1 would allow mains supplying fire hydrants to be less than 6" if the hydraulic calculations would support such a design. Based on the language on 5.2.2, AWWA recommendations and best practices for the design of water distribution lines supplying fire hydrants, the appropriate minimum size for mains supplying fire hydrants is no less than 6". This PI clarifies that the hydraulic calculations much occur but that those calculations cannot be utilized to justify installing mains of less than 6" supplying fire hydrants.

Submitter Information Verification

Submitter Full Name: Anthony Apfelbeck

Organization: Altamonte Springs Building and Fire Safety Department

Street Address:

City:

State:

Zip:

Submission Date: Wed May 08 10:04:15 EDT 2019

Committee: AUT-PRI

Committee Statement

Resolution: FR-6-NFPA 24-2019 PI 11 is also part of this FR PI 12 is also part of this FR

Statement: The current language in section 5.2.1 would allow mains supplying fire hydrants to be less than 6" if the hydraulic calculations would support such a design. Based on the language on 5.2.2, AWWA recommendations and best practices for the design of water distribution lines supplying fire hydrants, the appropriate minimum size for mains supplying fire hydrants is no less than 6". This PI clarifies that the hydraulic calculations much occur but that those calculations cannot be utilized to justify installing mains of less than 6" supplying fire hydrants.



Public Input No. 11-NFPA 24-2019 [Section No. 5.2.1]

5.2.1 Private Fire Service Mains.

Hydraulic calculations shall show that the main is able to supply the total demand at the appropriate required design pressure.

Statement of Problem and Substantiation for Public Input

This proposal is to eliminate the word “appropriate”, which is not enforceable.

Submitter Information Verification

Submitter Full Name: Larry Keeping
Organization: PLC Fire Safety Solutions
Street Address:
City:
State:
Zip:
Submittal Date: Sat Mar 16 22:01:43 EDT 2019
Committee: AUT-PRI

Committee Statement

Resolution: FR-6-NFPA 24-2019 PI 11 is also part of this FR PI 12 is also part of this FR

Statement: The current language in section 5.2.1 would allow mains supplying fire hydrants to be less than 6" if the hydraulic calculations would support such a design. Based on the language on 5.2.2, AWWA recommendations and best practices for the design of water distribution lines supplying fire hydrants, the appropriate minimum size for mains supplying fire hydrants is no less than 6". This PI clarifies that the hydraulic calculations much occur but that those calculations cannot be utilized to justify installing mains of less than 6" supplying fire hydrants.



Public Input No. 12-NFPA 24-2019 [Section No. 5.2.2]

5.2.2 Mains Not Supplying Hydrants.

For mains that do not supply hydrants, pipe sizes less than 6 in. (150 mm) nominal size shall be permitted to be used subject to the following restrictions:

- (1) The main shall supply only the following types of systems:
 - (2) Automatic sprinkler systems
 - (3) Open sprinkler systems
 - (4) Water spray fixed systems
 - (5) Foam systems
 - (6) Standpipe systems
- (7) Hydraulic calculations shall show that the main is able to supply the total demand at the appropriate required design pressure.
- (8) Systems that are not hydraulically calculated shall have a main at least as large as the riser.

Statement of Problem and Substantiation for Public Input

This proposal is to eliminate the word "appropriate", which is not enforceable.

Submitter Information Verification

Submitter Full Name: Larry Keeping
Organization: PLC Fire Safety Solutions
Street Address:
City:
State:
Zip:
Submittal Date: Sat Mar 16 22:04:33 EDT 2019
Committee: AUT-PRI

Committee Statement

Resolution: FR-6-NFPA 24-2019 PI 11 is also part of this FR PI 12 is also part of this FR

Statement: The current language in section 5.2.1 would allow mains supplying fire hydrants to be less than 6" if the hydraulic calculations would support such a design. Based on the language on 5.2.2, AWWA recommendations and best practices for the design of water distribution lines supplying fire hydrants, the appropriate minimum size for mains supplying fire hydrants is no less than 6". This PI clarifies that the hydraulic calculations much occur but that those calculations cannot be utilized to justify installing mains of less than 6" supplying fire hydrants.



Public Input No. 13-NFPA 24-2019 [Section No. 5.8]

5.8 Penstocks, Rivers, Lakes, or Reservoirs.

Water supply connections from penstocks, rivers, lakes, or reservoirs shall be designed to ~~avoid~~ prevent the introduction of mud and sediment and shall be provided with approved, double, removable screens or approved strainers installed in an approved manner.

5.8.1* When water supply connections are from penstocks, rivers, lakes, or reservoirs, special attention shall be given to prevent freezing either underground or underwater.

A.5.8.1 Intakes installed in surface water such as springs, creeks, lakes and man-made reservoirs should be designed to protect against ice development. Still water (non-flowing) will freeze at the air/water interface and form sheet ice reducing the total volume of available water for fire protection needs. Turbulent or flowing water can still have icing issues called frazil ice.

The density of water is at its highest at 39°F (4°C) causing any ice formations to float and not pose any potential danger to intakes below the surface. While ice may be present on the surface, warmer water may settle to the bottom of the reservoir. Circulating this warmer water can be another method of freeze protection. Further, submerged aeration systems whether by solar, wind or commercial power can create a mixing effect and prevent freezing.

The effects of cold temperatures can be estimated by obtaining the Freezing Index of the local area. The Freezing Index can be used to estimate the thickness of ice using the following formula:

Maximum Ice Thickness (in.) = 1.42 √ Freezing Index (°C)

For example a freezing index of 68 will result in: Maximum Ice Thickness = 1.42 √ 68 = 11.7 inches

Therefore an intake drawing water from a pond or lake in this locale should be deeper than 12 inches to remain free of any ice buildup during winter months.

For more information see Fact Sheet – Winter Considerations, Ice Formation, Freezing Index, and Frost Penetration, Ministry of Agriculture and Lands, British Columbia.

Statement of Problem and Substantiation for Public Input

This proposal regarding Section 5.8 is to eliminate the word “avoid”, which is not enforceable.

The new Section 5.8.1 and A.5.8.1 is proposed to alert users of the standard that as well as sediment and mud, when the water supply is from penstocks, rivers, lakes, or reservoirs, freezing considerations also have to be examined.

The text for the proposed 5.8.1 was adapted from Section 4.16.6.2.2 of NFPA 20-2019.

The text for the proposed A.5.8.1 was adapted from the Fact Sheet – Winter Considerations, Ice Formation, Freezing Index, and Frost Penetration, Ministry of Agriculture and Lands, British Columbia.

Submitter Information Verification

Submitter Full Name: Larry Keeping

Organization: PLC Fire Safety Solutions

Street Address:

City:

State:

Zip:

Submission Date: Sat Mar 16 22:07:35 EDT 2019

Committee: AUT-PRI

Committee Statement

Resolution: [FR-7-NFPA 24-2019](#)

Statement: This proposal regarding Section 5.8 is to eliminate the word “avoid”, which is not enforceable.

The new Section 5.8.1 and A.5.8.1 is proposed to alert users of the standard that as well as sediment and mud, when the water supply is from penstocks, rivers, lakes, or reservoirs, freezing considerations also have to be examined.

The text for the proposed 5.8.1 was adapted from Section 4.16.6.2.2 of NFPA 20-2019.

The text for the proposed A.5.8.1 was adapted from the Fact Sheet – Winter Considerations, Ice Formation, Freezing Index, and Frost Penetration, Ministry of Agriculture and Lands, British Columbia.



Public Input No. 14-NFPA 24-2019 [Section No. 5.9.1.3]

5.9.1.3-*

Fire department connections shall be equipped with approved plugs or caps that are secured and arranged for easy removal by fire departments.

[A.5.9.13 The caps need to be lubricated and installed wrench tight to avoid their inadvertent loss and to prevent corrosion or obstructive materials from being introduced, while still being capable of removal by fire department personnel, with the use of a hydrant/hose coupling wrench.](#)

Statement of Problem and Substantiation for Public Input

This proposal is to eliminate the word “easy”, which is not enforceable. Additionally, if the caps are easily removed, they would not necessarily be secure.

The new Annex text is offered to better clarify why the caps/plugs must be “secure” and how removal by the F.D. is to be accomplished.

Submitter Information Verification

Submitter Full Name: Larry Keeping
Organization: PLC Fire Safety Solutions
Street Address:
City:
State:
Zip:
Submission Date: Sat Mar 16 22:16:37 EDT 2019
Committee: AUT-PRI

Committee Statement

Resolution: [FR-8-NFPA 24-2019 Proposed annex material was not accepted.](#)

Statement: This proposal is to eliminate the word “easy”, which is not enforceable. Additionally, if the caps are easily removed, they would not necessarily be secure.

The new Annex text is offered to better clarify why the caps/plugs must be “secure” and how removal by the F.D. is to be accomplished.



Public Input No. 54-NFPA 24-2019 [New Section after 5.9.1.4]

5.9.1.5

A single fire department connection shall be permitted to supply multiple buildings where permitted by the AHJ.

Statement of Problem and Substantiation for Public Input

There are some situations where it is more desirable for the responding fire department to connect to a single FDC to pressurize multiple buildings. This could be a site where vehicle access may be limited. It could also be on a site with multiple buildings supplied by a single fire pump.

Submitter Information Verification

Submitter Full Name: Peter Schwab
Organization: Wayne Automatic Fire Sprinkler
Street Address:
City:
State:
Zip:
Submittal Date: Mon Jun 10 15:03:17 EDT 2019
Committee: AUT-PRI

Committee Statement

Resolution: FR-9-NFPA 24-2019 Insert as a new 5.9.1.2 and renumber 5.9.1.2 and subsequent sections.

Statement: There are some situations where it is more desirable for the responding fire department to connect to a single FDC to pressurize multiple buildings. This could be a site where vehicle access may be limited. It could also be on a site with multiple buildings supplied by a single fire pump.



Public Input No. 45-NFPA 24-2019 [Section No. 5.9.2.4]

5.9.2.4

Nonthreaded couplings shall be permitted where required by the AHJ.

5.9.2.4.1

Nonthreaded couplings shall be listed.

5.9.2.4.2*

Nonthreaded fire department connection couplings, which are greater than 3", shall be equipped with an intergal straining screen.

A.5.9.2.4.2*

Fire department connections, which are greater than 3", are particularly susceptible to debris being disposed of within the connection. Integral screens, as part of the listed device, are a key component to ensuring the integrity of the large orifice fire department connections.

Statement of Problem and Substantiation for Public Input

Fire department connections, which are greater than 3", are particularly susceptible to debris being disposed of within the connection. Integral screens, as part of the listed device, are a key component to ensuring the integrity of the large orifice fire department connections. This PI ensures that large orifice FDC's are provided with screens and such screens are part of the listing of the device.

Submitter Information Verification

Submitter Full Name: Anthony Apfelbeck

Organization: Altamonte Springs Building and Fire Safety Department

Street Address:

City:

State:

Zip:

Submittal Date: Wed May 08 10:13:10 EDT 2019

Committee: AUT-PRI

Committee Statement

Resolution: Obstructions issues are not limited to 3" and above but also 2.5"



Public Input No. 15-NFPA 24-2019 [Section No. 5.9.5.1]

5.9.5.1*

Remote fire department connections shall be located ~~at the nearest point of~~ [adjacent to a street or an access route, to permit](#) fire department apparatus accessibility or at a location approved by the AHJ.

Statement of Problem and Substantiation for Public Input

This proposal is to eliminate the word “nearest”, since it may not be always practical or desirable to locate an FDC at the nearest point, depending on the landscaping, etc.

Submitter Information Verification

Submitter Full Name: Larry Keeping
Organization: PLC Fire Safety Solutions
Street Address:
City:
State:
Zip:
Submittal Date: Sat Mar 16 22:21:21 EDT 2019
Committee: AUT-PRI

Committee Statement

Resolution: [FR-10-NFPA 24-2019](#)

Statement: This proposal is to eliminate the word “nearest”, since it may not be always practical or desirable to locate an FDC at the nearest point, depending on the landscaping, etc.



Public Input No. 16-NFPA 24-2019 [Section No. 6.2.7]

6.2.7

Where a pump is located in a combustibile pump house or exposed to danger from fire or falling walls, or where a tank discharges into a private fire service main fed by another supply, one of the following requirements shall be met:

- (1) * The check valve in the connection shall be located in a pit.
- (2) The control valve shall be of the post indicator type and located ~~a safe distance outside buildings~~ - [not less than 40 ft \(12 m\) from](#) .
- (3) [For buildings less than 40 ft \(12 m\) in height, a post indicator valve shall be permitted to be installed closer than 40 ft \(12 m\) but at least as far from the building as the height of the wall facing the post indicator valve .](#)

Statement of Problem and Substantiation for Public Input

This proposal is to eliminate the words "safe distance", which is not enforceable. The new text is provided to specify the where the valve needs to be located.

Submitter Information Verification

Submitter Full Name: Larry Keeping
Organization: PLC Fire Safety Solutions
Street Address:
City:
State:
Zip:
Submittal Date: Sat Mar 16 22:26:04 EDT 2019
Committee: AUT-PRI

Committee Statement

Resolution: [FR-11-NFPA 24-2019](#)

Statement: This proposal is to eliminate the words "safe distance", which is not enforceable. The new text is provided to specify the where the valve needs to be located.



Public Input No. 47-NFPA 24-2019 [Section No. 6.2.9]

6.2.9

All connections to private fire service mains for fire protection systems shall be arranged in accordance with one of the following so that they can be isolated:

- (1) * A post indicator valve installed not less than 40 ft (12 m) from the building
- (2) For buildings less than 40 ft (12 m) in height, a post indicator valve shall be permitted to be installed closer than 40 ft (12 m) but at least as far from the building as the height of the wall facing the post indicator valve.
- (3) A wall post indicator valve
- (4) An indicating valve in a pit, installed in accordance with Section 6.4
- (5) * A backflow preventer with at least one indicating valve not less than 40 ft (12 m) from the building
 - (6) For buildings less than 40 ft (12 m) in height, a backflow preventer with at least one indicating valve shall be permitted to be installed closer than 40 ft (12 m) but at least as far from the building as the height of the wall facing the backflow preventer.
- (7) * A nonindicating valve, such as an underground gate valve with an approved roadway box, complete with T-wrench, located not less than 40 ft (12 m) from the building
 - (8) For buildings less than 40 ft (12 m) in height, a nonindicating valve, such as an underground gate valve with an approved roadway box, complete with T-wrench, shall be permitted to be installed closer than 40 ft (12 m) but at least as far from the building as the height of the wall facing the non-indicating valve.
- (9) Control valves installed in a fire-rated room accessible from the exterior
- (10) Control valves in a fire-rated stair enclosure accessible from the exterior as permitted by the AHJ

Statement of Problem and Substantiation for Public Input

Delete the requirement for the PIV to be 40 ft. from the building (and delete the annex material as well). Item No.2 allows for a Wall PIV to be mounted on the building , so why should a PIV be required to be located away from the building by any specific distance. This requirement is often not feasible and often not enforced.

Submitter Information Verification

Submitter Full Name: James Peterkin
Organization: TLC Engineering
Street Address:
City:
State:
Zip:
Submission Date: Wed Jun 05 07:59:02 EDT 2019
Committee: AUT-PRI

Committee Statement

Resolution: It is desirable to keep the valve at a safe distance from the building.



Public Input No. 17-NFPA 24-2019 [Sections 6.4.1, 6.4.2, 6.4.3]

Sections 6.4.1, 6.4.2, 6.4.3

6.4.1

Valve pits located at or near the base of the riser of [on the discharge pipe](#) of an elevated tank shall be designed in accordance with Chapter 14 of NFPA 22.

6.4.2

Where used, valve pits shall be of adequate size and accessible [a size to permit access](#) for inspection, operation, testing, maintenance, and removal of equipment contained therein.

6.4.3

Valve pits shall be constructed and arranged properly to protect the installed equipment from movement of earth, freezing, and accumulation of water.

6.4.3.1

Depending on soil conditions and the size of the pit, valve pits shall be permitted to be constructed of any of the following materials:

- (1) Poured-in-place or precast concrete, with or without reinforcement
- (2) Brick
- (3) Other approved materials

6.4.3.2

Where the water table is low and the soil is porous, crushed stone or gravel shall be permitted to be used for the floor of the pit.

Statement of Problem and Substantiation for Public Input

This proposal is to revise 6.4.1, 6.4.2 and 6.4.3 to eliminate the terms “or near”, “adequate” and “appropriate”, which are not enforceable.

The new text is for 6.4.1 is proposed, to better specify when the valve pit must be installed per NFPA 22 and the reference to Chapter 14 of NFPA 22 was deleted, because with the revisions to that standard, the requirements for pits and valve houses is no longer in that chapter.

Submitter Information Verification

Submitter Full Name: Larry Keeping
Organization: PLC Fire Safety Solutions
Street Address:
City:
State:
Zip:
Submission Date: Sat Mar 16 22:34:52 EDT 2019
Committee: AUT-PRI

Committee Statement

Resolution: [FR-12-NFPA 24-2019](#)

Statement: This proposal is to revise 6.4.1, 6.4.2 and 6.4.3 to eliminate the terms “or near”, “adequate” and “appropriate”, which are not enforceable.

The new text is for 6.4.1 is proposed, to better specify when the valve pit must be installed per NFPA

22 and the reference to Chapter 14 of NFPA 22 was deleted, because with the revisions to that standard, the requirements for pits and valve houses is no longer in that chapter.



Public Input No. 18-NFPA 24-2019 [Section No. 6.6.1]

6.6.1*

Sectional valves shall be provided at appropriate locations within piping sections such that the number of fire protection connections between sectional valves does not exceed six.

Statement of Problem and Substantiation for Public Input

This proposal is to eliminate the word “appropriate”, which is not enforceable.

Submitter Information Verification

Submitter Full Name: Larry Keeping
Organization: PLC Fire Safety Solutions
Street Address:
City:
State:
Zip:
Submission Date: Sat Mar 16 22:46:46 EDT 2019
Committee: AUT-PRI

Committee Statement

Resolution: [FR-13-NFPA 24-2019 PI 53 is also part of the FR.](#)

Statement: This proposal is to eliminate the word “appropriate”, which is not enforceable.



Public Input No. 53-NFPA 24-2019 [Section No. 6.6.1]

6.6.1 *

Sectional valves shall be provided at on loop systems at appropriate locations within piping sections such that the number of fire protection connections between sectional valves does not exceed six.

Statement of Problem and Substantiation for Public Input

This section should apply to loop systems not all systems. On a dead end system, this section only provides a benefit if the section that needs repair is the last 6 fire protection connections.

Submitter Information Verification

Submitter Full Name: Peter Schwab
Organization: Wayne Automatic Fire Sprinkler
Street Address:
City:
State:
Zip:
Submittal Date: Mon Jun 10 14:58:17 EDT 2019
Committee: AUT-PRI

Committee Statement

Resolution: [FR-13-NFPA 24-2019 PI 53](#) is also part of the [FR](#).

Statement: This proposal is to eliminate the word "appropriate", which is not enforceable.



Public Input No. 19-NFPA 24-2019 [Section No. 7.1.1.3]

7.1.1.3*

The number, size, and arrangement of outlets; the size of the main valve opening; and the size of the barrel shall be suitable- [determined by the required flow and pressure](#) _ for the protection to be provided and shall be approved by the AHJ.

Statement of Problem and Substantiation for Public Input

This proposal is to eliminate the term “suitable for”, which is not enforceable.

Submitter Information Verification

Submitter Full Name: Larry Keeping
Organization: PLC Fire Safety Solutions
Street Address:
City:
State:
Zip:
Submittal Date: Sat Mar 16 22:48:59 EDT 2019
Committee: AUT-PRI

Committee Statement

Resolution: [FR-14-NFPA 24-2019](#)

Statement: This proposal is to eliminate the term “suitable for”, which is not enforceable.



Public Input No. 1-NFPA 24-2018 [New Section after 7.1.3]

Add a new 7.1.4 as follows:

7.1.4 Hydrants shall be painted in accordance with the requirements of the authority having jurisdiction.

Statement of Problem and Substantiation for Public Input

Many jurisdictions have specifications for the painting of fire hydrants. Some of those specifications include painting hydrants in accordance with standards that communicate to the operations fire department staff the flow availability from a fire hydrant. It is reasonable to conclude that a new hydrant installation should include the painting of a fire hydrant to the jurisdiction's specifications. If it is not included in NFPA 24, then when and who would be expected to paint the hydrant or assign a color code if the flow test data is required to be represented on the hydrant? It seems intuitive that the fire protection contractor installing the hydrant should have this responsibility and that responsibility should be called out in NFPA 24.

Submitter Information Verification

Submitter Full Name: Anthony Apfelbeck
Organization: Altamonte Springs Building/Fire Safety Division
Street Address:
City:
State:
Zip:
Submission Date: Fri Oct 12 12:58:05 EDT 2018
Committee: AUT-PRI

Committee Statement

Resolution: This is redundant language since an AHJ may already require a hydrant to be painted a certain color.



Public Input No. 20-NFPA 24-2019 [Section No. 7.2]

7.2 Number and Location.

7.2.1*

Hydrants shall be provided and spaced in accordance with the requirements of the AHJ.

7.2.1.1 Fire hydrants shall be provided in accordance with both of the following:

(1) The maximum distance to a fire hydrant from the closest point on the building shall not exceed 400 ft (120 m). [NFPA 1:18.5.3]

(2) The maximum distance between fire hydrants shall not exceed 500 ft (150 m). [NFPA 1:18.5.3]

7.2.2

Public hydrants shall be permitted to be recognized as meeting all or part of the requirements of Section 7.2.

7.2.3* – Fire hydrants shall be located not more than 12 ft (3.7 m) from the fire department access road. [NFPA 1: 18.5.1.6]

7.2.4* Hydrants shall be located not less than 40 ft (12 m) from the buildings to be protected.

7.2.4 – 5

Where hydrants cannot be located in accordance with 7.2.3, hydrants located closer than 40 ft (12 m) from the building or wall hydrants shall be permitted to be used where approved by the AHJ.

7.3 Clear Space Around Hydrants. [NFPA 1:18.5.7]

7.3.1 A 36 in. (900 mm) clear space shall be maintained around the circumference of fire hydrants except as otherwise required or approved. [NFPA 1:18.5.7.1]

7.3.2 A clear space of not less than 60 in. (1500 mm) shall be provided in front of each hydrant connection having a diameter greater than 2½ in. (65 mm).[NFPA 1:18.5.7.2]

7.4 Marking of Hydrants. [NFPA 1: 18.5.10]

7.4.1 Fire hydrants shall be marked with an approved reflector affixed to the roadway surface where required by the AHJ. [NFPA 1: 18.5.10.1]

7.4.2 Fire hydrants shall be marked with an approved flag or other device affixed to or proximate to the fire hydrant where required by the AHJ. [NFPA 1:18.5.10.2]

7.4.3* Where required by the AHJ, fire hydrants shall be color coded or otherwise marked with an approved system indicating the available flow capacity. [NFPA 1: 18.5.10.3*]

Also renumber the existing A.7.2.3 as A.7.2.4 and add the new A.7.4.3 as follows:

A.7.4.3 Color coding or stenciling a fire hydrant with the actual flow capacity are two methods to accomplish the capacity marking of fire hydrants when it is required by the AHJ. NFPA 291, Recommended Practice for Fire Flow Testing and Marking of Hydrants, specifies the following approach to hydrant marking for flow indication:

Classification of Hydrants. Hydrants should be classified in accordance with their rated capacities [at 20 psi (1.4 bar) residual pressure or other designated value] as follows:

- (1) Class AA — Rated capacity of 1500 gpm (5700 L/min) or greater
- (2) Class A — Rated capacity of 1000–1499 gpm (3800– 5675 L/min)
- (3) Class B — Rated capacity of 500–999 gpm (1900–3780 L/ min)
- (4) Class C — Rated capacity of less than 500 gpm (1900 L/ min)

The tops and nozzle caps should be painted with the following capacity-indicating color scheme:

- (1) Class AA — Light blue
- (2) Class A — Green
- (3) Class B — Orange
- (4) Class C — Red paint

The capacity colors should be of a reflective-type paint. [NFPA 1: A.18.5.10.3]

Renumber the existing Section 7.3 as 7.5.

Statement of Problem and Substantiation for Public Input

One of the problems in dealing with NFPA 24 is that it does not provide enough information concerning hydrant location, spacing, clearances, etc. By extracting the pertinent provisions from NFPA 1, this proposal fills that gap.

Submitter Information Verification

Submitter Full Name: Larry Keeping
Organization: PLC Fire Safety Solutions
Street Address:
City:
State:

Zip:

Submittal Date: Sat Mar 16 23:07:36 EDT 2019

Committee: AUT-PRI

Committee Statement

Resolution: Code language is not appropriate in a standard.



Public Input No. 21-NFPA 24-2019 [Sections 7.3.1, 7.3.2]

Sections 7.3.1, 7.3.2

7.3.1*

Hydrants shall be installed on flat stones, concrete slabs or other approved materials.

7.3.2

Small stones or an approved equivalent shall be provided about the drain for dry barrel hydrants .

7.3.2.1

Where soil is such that the hydrants will not drain properly with the arrangement specified in 7.3.2, or where groundwater stands at levels above that of the drain, the hydrant drain shall be plugged before installation.

7.3.2.1.1*

Hydrants with drain plugs shall be marked to indicate the need for pumping out after usage.

Also revise A.7.3.1 as follows:

A.7.3.1 See Figure A.7.3.1 (a) and Figure A.7.3.1(b) .

Delete existing Figures A7.3.1(a) and A.7.3.1(b) and replace them with the following new Figure A.7.3.1:

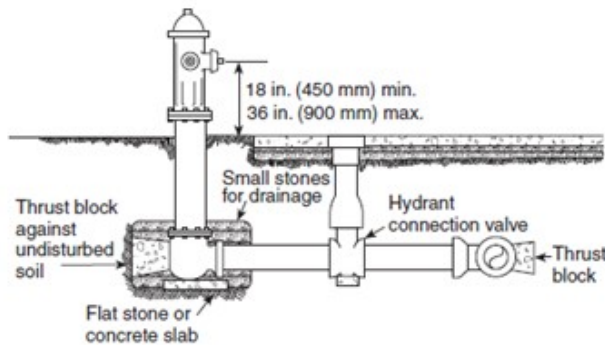

Figure A.7.3.1 Typical Dry Barrel Hydrant Connection

Statement of Problem and Substantiation for Public Input

This proposal is to clarify that only dry barrel hydrants require a bed of stone for drainage. Wet barrel hydrants are not equipped with drain ports.

This proposal is also to eliminate redundancy. The only difference between the current Figures A.7.3.1(a) and A.7.3.1(b) is the maximum and minimum heights of the hydrant outlets. Those values can be shown on just one illustration.

Additionally, for 7.3.2.1 the word "properly" is proposed to be deleted, because the tem is unenforceable.

Submitter Information Verification

Submitter Full Name: Larry Keeping

Organization: PLC Fire Safety Solutions

Street Address:

City:

State:

Zip:

Submittal Date: Sat Mar 16 23:24:02 EDT 2019

Committee: AUT-PRI

Committee Statement

Resolution: [FR-16-NFPA 24-2019 PI 43](#) is included as part of [FR 16](#)

Statement: This proposal is to clarify that only dry barrel hydrants require a bed of stone for drainage. Wet barrel hydrants are not equipped with drain ports.

This proposal is also to eliminate redundancy. The only difference between the current Figures A.7.3.1(a) and A.7.3.1(b) is the maximum and minimum heights of the hydrant outlets. Those values can be shown on just one illustration.

Additionally, for 7.3.2.1 the word "properly" is proposed to be deleted, because the tem is unenforceable.



Public Input No. 43-NFPA 24-2019 [Section No. 7.3.2 [Excluding any Sub-Sections]]

Small stones or an approved equivalent shall be provided about the drain below and around the drain in an adequate amount to prevent the weep hole from being clogged with native soil, mud or debris that would prevent adequate drainage .

Statement of Problem and Substantiation for Public Input

the term, "about the drain" doesn't adequately describe the need to provide enough gravel for drainage. By stating the reason, installers and AHJ's might be encouraged to add enough gravel or stones to prevent the inevitable future drainage problems often found with private hydrants

Submitter Information Verification

Submitter Full Name: Robert Caputo
Organization: Fire & Life Safety America
Street Address:
City:
State:
Zip:
Submittal Date: Thu Apr 18 15:50:45 EDT 2019
Committee: AUT-PRI

Committee Statement

Resolution: [FR-16-NFPA 24-2019 PI 43](#) is included as part of [FR 16](#)

Statement: This proposal is to clarify that only dry barrel hydrants require a bed of stone for drainage. Wet barrel hydrants are not equipped with drain ports.

This proposal is also to eliminate redundancy. The only difference between the current Figures A.7.3.1(a) and A.7.3.1(b) is the maximum and minimum heights of the hydrant outlets. Those values can be shown on just one illustration.

Additionally, for 7.3.2.1 the word "properly" is proposed to be deleted, because the tem is unenforceable.



Public Input No. 22-NFPA 24-2019 [Section No. 7.3.6]

7.3.6

The following shall not be installed in the service stub between a fire hydrant and private water supply piping:

- (1) Check valves
- (2) Detector check valves
- (3) Backflow prevention valves
- (4) Other ~~similar~~ appurtenances

Statement of Problem and Substantiation for Public Input

This proposal is to eliminate the word "similar", which is not enforceable.

Submitter Information Verification

Submitter Full Name: Larry Keeping
Organization: PLC Fire Safety Solutions
Street Address:
City:
State:
Zip:
Submittal Date: Sat Mar 16 23:40:49 EDT 2019
Committee: AUT-PRI

Committee Statement

Resolution: The term "similar" in this section provides value in relation to the other products listed.



Public Input No. 51-NFPA 24-2019 [Section No. 7.3.6]

7.3.6

The following shall not be ~~installed in the service stub between~~ installed between a fire hydrant and private water supply piping ~~the control valve for that hydrant~~ :

- (1) Check valves
- (2) Detector check valves
- (3) Backflow prevention valves
- (4) Other similar appurtenances

Statement of Problem and Substantiation for Public Input

The term "service stub" is not defined. The intention of this section is to not install one of these devices in the hydrant assembly. Realistically, as long as the device has been listed and evaluated, why can't a device such as this be installed?

Submitter Information Verification

Submitter Full Name: Peter Schwab
Organization: Wayne Automatic Fire Sprinkler
Street Address:
City:
State:
Zip:
Submittal Date: Mon Jun 10 14:49:08 EDT 2019
Committee: AUT-PRI

Committee Statement

Resolution: [FR-18-NFPA 24-2019](#)

Statement: The term "service stub" is not defined. The intention of this section is to not install one of these devices in the hydrant assembly. Realistically, as long as the device has been listed and evaluated, why can't a device such as this be installed?



Public Input No. 23-NFPA 24-2019 [Section No. 8.2.2]

8.2.2

Hydrants within hose houses shall be ~~as close to~~ located at the front of the house ~~as possible and still~~ allow sufficient with room behind the doors for the hose gates and the attached hose.

Statement of Problem and Substantiation for Public Input

This proposal is to eliminate the terms “as possible and “sufficient”, which are not enforceable.

Submitter Information Verification

Submitter Full Name: Larry Keeping
Organization: PLC Fire Safety Solutions
Street Address:
City:
State:
Zip:
Submittal Date: Sat Mar 16 23:42:39 EDT 2019
Committee: AUT-PRI

Committee Statement

Resolution: [FR-19-NFPA 24-2019](#)

Statement: This proposal is to eliminate the terms “as possible and “sufficient”, which are not enforceable.



Public Input No. 24-NFPA 24-2019 [Sections 9.1, 9.2]

Sections 9.1, 9.2

9.1* Master Streams.

Master streams shall be delivered by monitor nozzles, hydrant-mounted monitor nozzles, and similar- other master stream equipment capable of delivering more than 250 gpm (950 ~~lpm~~ L/min).

9.2 Application and Special Considerations Situations .

Master streams shall be provided as protection for the following:

- (1) Large amounts of combustible materials located in yards
- (2) Average- Substantial amounts of combustible materials in inaccessible locations
- (3) Occupancies presenting special hazards, as required by the authority having jurisdiction

Statement of Problem and Substantiation for Public Input

This proposal is to eliminate the terms “similar”, “considerations” and “average”, which are not enforceable.

Additionally, the abbreviation for liters per minute was editorially corrected from “lpm” to “L/min”.

Submitter Information Verification

Submitter Full Name: Larry Keeping

Organization: PLC Fire Safety Solutions

Street Address:

City:

State:

Zip:

Submittal Date: Sat Mar 16 23:45:59 EDT 2019

Committee: AUT-PRI

Committee Statement

Resolution: FR-20-NFPA 24-2019

Statement: This proposal is to eliminate the terms “similar”, “considerations” and “average”, which are not enforceable.

Additionally, the abbreviation for liters per minute was editorially corrected from “lpm” to “L/min”.



Public Input No. 46-NFPA 24-2019 [Section No. 10.1.1.1]

A large, empty rectangular box with a thin border, intended for public input or comments.

10.1.1.1 Listing Use .

Piping manufactured in accordance with Table 10.1.1.1 shall be permitted to be used.

Table 10.1.1.1 Manufacturing Standards for Underground Pipe

AWWA-C905

Materials and Dimensions	Standard
Ductile Iron	-
<i>Cement-Mortar Lining for Ductile-Iron Pipe and Fittings</i>	AWWA C104/A21.4
<i>Polyethylene Encasement for Ductile-Iron Pipe Systems</i>	AWWA C105/A21.5
<i>Rubber-Gasket Joints for Ductile-Iron Pressure Pipe and Fittings</i>	AWWA C111/A21.11
<i>Flanged Ductile-Iron Pipe with Ductile-Iron or Gray-Iron Threaded Flanges</i>	AWWA C115/A21.15
<i>Thickness Design of Ductile-Iron Pipe</i>	AWWA C150/A21.50
<i>Ductile-Iron Pipe, Centrifugally Cast</i>	AWWA C151/A21.51
<i>Standard for the Installation of Ductile Iron Water Mains and Their Appurtenances</i>	AWWA C600
-	-
Concrete	-
<i>Reinforced Concrete Pressure Pipe, Steel-Cylinder Type</i>	AWWA C300
<i>Prestressed Concrete Pressure Pipe, Steel-Cylinder Type</i>	AWWA C301
<i>Reinforced Concrete Pressure Pipe, Non-Cylinder Type</i>	AWWA C302
<i>Reinforced Concrete Pressure Pipe, Steel-Cylinder Type, Pretensioned</i>	AWWA C303
-	-
<i>Cement-Mortar Lining of Water Pipe Lines in Place, 4 in. (100 mm) and Larger</i>	AWWA C602
-	-
Plastic	-
<i>Polyvinyl Chloride (PVC) Pressure Pipe, 4 in. Through 12 in. (100 mm Through 300 mm), for Water Transmission and Distribution</i>	AWWA C900
<i>Polyethylene (PE) Pressure Pipe and Fittings, 4 in. (100 mm) Through 63 in. (1575 mm) for Waterworks</i>	AWWA C906
<i>Molecularly Oriented Polyvinyl Chloride (PVCO), 4 in. Through 24 in. (100 mm Through 600 mm) for Water, Wastewater, and Reclaimed Water Service</i>	AWWA C909
-	-
<i>Polyvinyl Chloride (PVC) Pressure Pipe and Fabricated Fittings, 14 in 4 In . Through 48 in 60 In . (350 mm Through 1200 mm), for Water Transmission and Distribution</i>	AWWA C900
	100 mm Through 1,500 mm)

Materials and Dimensions	Standard
Brass	-
<i>Specification for Seamless Red Brass Pipe, Standard Sizes</i>	ASTM B43
-	-
Copper	-
<i>Specification for Seamless Copper Tube</i>	ASTM B75/B75M
<i>Specification for Seamless Copper Water Tube</i>	ASTM B88
<i>Requirements for Wrought Seamless Copper and Copper-Alloy Tube</i>	ASTM B251
Stainless Steel	-
<i>Standard Specification for Seamless, Welded, and Heavily Cold Worked Austenitic Stainless Steel Pipes</i>	ASTM A312/312M

Statement of Problem and Substantiation for Public Input

There are two changes proposed here. The first is just to change the title of the section from "Listing" to "Uses". This is suggested because the standard does not require a listing. As long as the pipe is manufactured in accordance with the table, it is not required to be listed. If the title "Listing" is used at all, it should be used with 10.1.1.2

The other change is to correct the title of C900 pipe to expand it to 60 inches (1500mm). This is consistent with the change made by the AWWA to consolidate C905 into C900 and get rid of C905. There are no longer two standards. AWWA now uses C900 for all sizes of PVC pipe from small to very large.

Submitter Information Verification

Submitter Full Name: Kenneth Isman
Organization: University of Maryland
Street Address:
City:
State:
Zip:
Submission Date: Fri May 17 16:50:12 EDT 2019
Committee: AUT-PRI

Committee Statement

Resolution: [FR-21-NFPA 24-2019](#) The table was also revised to remove the title of each referenced standard under the "Materials and Dimensions" heading as it is the intent to list the material and not the standard's title. See attached file

Statement: There are two changes proposed here. The first is just to change the title of the section from "Listing" to "Uses". This is suggested because the standard does not require a listing. As long as the pipe is manufactured in accordance with the table, it is not required to be listed. If the title "Listing" is used at all, it should be used with 10.1.1.2

The other change is to correct the title of C900 pipe to expand it to 60 inches (1500mm). This is consistent with the change made by the AWWA to consolidate C905 into C900 and get rid of C905. There are no longer two standards. AWWA now uses C900 for all sizes of PVC pipe from small to very large.



Public Input No. 25-NFPA 24-2019 [Section No. 10.1.4]

10.1.4*

Underground piping shall be permitted to extend into the building through the slab or wall not more than 24 in. (600 mm).

[10.1.4.1 Underground piping extended vertically into the building through the slab shall be installed plumb.](#)

Statement of Problem and Substantiation for Public Input

This proposal offered as an attempt to try to eliminate a common site problem, whereby the spigot piece of an underground installation is not installed "true", such that extra fittings or a dutchman or a wedge gasket is needed to align the fire protection system(s) inside the building.

Submitter Information Verification

Submitter Full Name: Larry Keeping
Organization: PLC Fire Safety Solutions
Street Address:
City:
State:
Zip:
Submittal Date: Sat Mar 16 23:48:43 EDT 2019
Committee: AUT-PRI

Committee Statement

Resolution: [FR-22-NFPA 24-2019](#)

Statement: This proposal offered as an attempt to try to eliminate a common site problem, whereby the spigot piece of an underground installation is not installed "true", such that extra fittings or a dutchman or a wedge gasket is needed to align the fire protection system(s) inside the building.



Public Input No. 38-NFPA 24-2019 [Section No. 10.2.1.1]

A large, empty rectangular box with a thin black border, intended for public input or comments.

steel pipe fittings should be deleted from the table. However, for some reason in the TerraView copy of the table, the provisions for copper and bronze fittings were inadvertently shown in "strikeout text" as well, so now, as published, the table only recognizes cast iron and ductile iron fittings as appropriate for underground piping installations.

Additionally, in Public Comment No. 6, it was proposed to add the references for stainless steel fittings, to correspond with the information shown in NFPA 13 - 2016, Table 6.4.1. This matter was "accepted in principle" by the Technical Committee and it was intended to be reflected in Second Revision No. 7, but mistakenly, it was not included.

The missing information needs to be added to Table, 10.2.1.1, to allow the appropriate fittings to be utilized when copper, bronze or stainless steel pipe is employed in underground piping installations.

Also, please note that since Table 10.2.1.1 is extracted into NFPA 13 - 2019 as Table 6.2.1.1, the missing information needs to be added to NFPA 13, Table 6.2.1.1 as well.

Submitter Information Verification

Submitter Full Name: Larry Keeping
Organization: PLC Fire Safety Solutions
Street Address:
City:
State:
Zip:
Submittal Date: Sun Mar 17 14:48:01 EDT 2019
Committee: AUT-PRI

Committee Statement

Resolution: FR-23-NFPA 24-2019 Removed "specification for" since this table is not intended to be a listing of the standard titles.

Statement: This proposal seeks to rectify a discrepancy that was introduced during the Second Draft stage of the revision process, when as per Public Comment No. 11, and Second Revision No. 7, it was requested that the references to steel pipe fittings should be deleted from the table. However, for some reason in the TerraView copy of the table, the provisions for copper and bronze fittings were inadvertently shown in "strikeout text" as well, so now, as published, the table only recognizes cast iron and ductile iron fittings as appropriate for underground piping installations.

Additionally, in Public Comment No. 6, it was proposed to add the references for stainless steel fittings, to correspond with the information shown in NFPA 13 - 2016, Table 6.4.1. This matter was "accepted in principle" by the Technical Committee and it was intended to be reflected in Second Revision No. 7, but mistakenly, it was not included.

The missing information needs to be added to Table, 10.2.1.1, to allow the appropriate fittings to be utilized when copper, bronze or stainless steel pipe is employed in underground piping installations.

Also, please note that since Table 10.2.1.1 is extracted into NFPA 13 - 2019 as Table 6.2.1.1, the missing information needs to be added to NFPA 13, Table 6.2.1.1 as well.



Public Input No. 26-NFPA 24-2019 [Section No. 10.4.3]

10.4.3 Private Fire Service Mains Under Buildings.

Except as ~~allowed~~ permitted by 10.4.3, private fire service mains shall not be ~~allowed to be~~ run under buildings.

10.4.3.1*

Private fire service mains supplying fire protection systems within the building shall be permitted to extend no more than 10 ft (3.0 m), as measured from the outside of the building, under the building to the riser location.

10.4.3.1.1* – _

Pipe joints shall not be located directly under foundation footings.

10.4.3.1.2* – _

Piping shall be installed a minimum of 12 in. (300 mm) below the bottom of building foundations or footers.

10.4.3.1.2.1

The requirements of 10.4.3.1.2 shall not apply when the piping is sleeved with an approved material.

10.4.3.2*

Private fire service mains shall not be permitted to extend more than 10 ft (3 m) under the building except as allowed in 10.4.3.2.1.

10.4.3.2.1 – *_

Where private fire service mains extend more than 10 ft (3 m) into the building, they shall be run in a covered trench.

10.4.3.2.1.1*

The trench shall be accessible from within the building.

10.4.3.2.1.2

The trench shall have rigid walls and a base.

10.4.3.2.1.3

The trench shall be constructed of noncombustible materials.

10.4.3.2.1.4*

Provisions for draining water shall be provided for the trench.

10.4.3.2.1.5

Where the piping in the trench is installed under foundations or footers, clearance shall be provided in accordance with 10.4.3.1.2 or 10.4.3.1.2.1.

10.4.3.2.2

Piping in the trench shall be permitted to be in accordance with 10.1.1.

10.4.3.2.2.1

Aboveground piping in accordance with NFPA 13 shall be permitted to be used.

10.4.3.2.2.2

Where piping installed in the trench is in accordance with 10.1.1, all joints shall be restrained in accordance with 10.6.2 or 10.6.3.

10.4.3.2.3*

Where piping is installed in a trench as permitted by 10.4.3.2.1, a valve shall be provided where the underground piping enters the trench.

10.4.3.2.4

When piping is installed in a trench, bury depths of 10.4.2.2 shall not apply.

10.4.3.2.4.1

Piping in the trench shall be protected from freezing in accordance with 10.4.2.1.4.

Also Revise Section A.10.4.3.1.1 and A.10.4.3.2.2 and Delete Figures A.10.4.3.1, A.10.4.3.1.1 and A.10.4.3.1.2 and replace them with the following new Figure A.10.4.3.1:as follows:

A.10.4.3.1.1 The individual piping standards should be followed for load and bury depth, accounting for the load and stresses imposed by the building foundation.

Figure A.10.4.3.1.1 shows location where pipe joints would be prohibited.

A.10.4.3.1.2 Sufficient clearance should be provided when piping passes beneath foundations or footers. See Figure A.10.4.3.1.2.

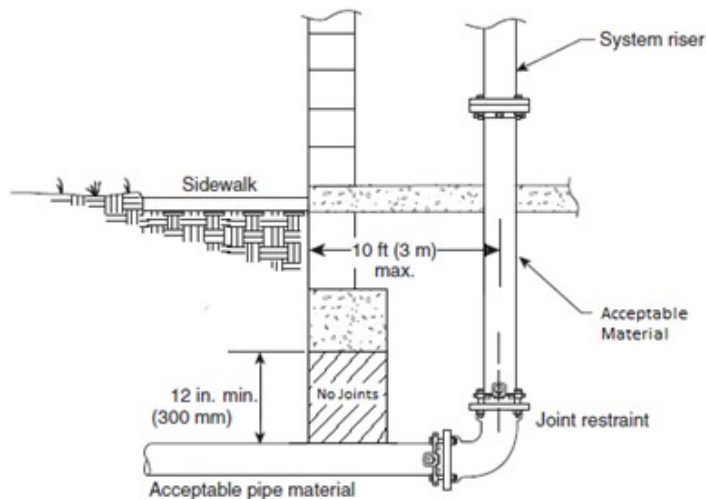

FIGURE A.10.4.3.1 Riser Entrance Location and Clearance

Also add a new Section A.10.4.3.2.1 and add a new Figure A.10.4.3.2.1, as follows:

A.10.4.3.2.1 See Figure A.10.4.3.2.1

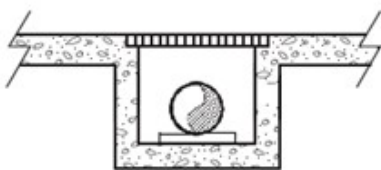

Figure A.10.4.3.2.1 Private Service Main in a Covered Trench

Statement of Problem and Substantiation for Public Input

This proposal is to eliminate the word “allowed”, which is used twice in the current 10.4.3 and to eliminate redundancy, and to provide an illustration of a main being run in a covered trench below the floor.

The only significant difference between the current Figures A.10.4.3.1, A.10.4.3.1.1 and A.10.4.3.1.2 is the maximum distance inside the building, the minimum distance below the footing and the area below the footing where no joints are allowed. Those matter can be shown on just one illustration.

These actions call for the asterix (*) for Sections 10.4.3.1.1 and 10.4.3.1.2 to be deleted and for a new asterix (*) to be added to Section 10.4.3.2.1.

Submitter Information Verification

Submitter Full Name: Larry Keeping

Organization: PLC Fire Safety Solutions

Committee Statement

City:

Resolution: FR-24-NFPA 24-2019

State:

Statement: This proposal is to eliminate the word "allowed", which is used twice in the current 10.4.3 and to eliminate redundancy. and to provide an illustration of a main being run in a covered trench below

Zip: floor. Sun Mar 17 13:27:39 EDT 2019

Submittal Date:

AUT-PRI

The only significant difference between the current Figures A.10.4.3.1, A.10.4.3.1.1 and A.10.4.3.1.2 is the maximum distance inside the building, the minimum distance below the footing and the area below the footing where no joints are allowed. Those matter can be shown on just one illustration.

These actions call for the asterix (*) for Sections 10.4.3.1.1 and 10.4.3.1.2 to be deleted and for a new asterix (*) to be added to Section 10.4.3.2.1.



Public Input No. 56-NFPA 24-2019 [New Section after 10.6.2]

10.6.2.1

Restrained joint systemys shall not be required to be listed.

Statement of Problem and Substantiation for Public Input

The standard currently implies that restraint methods are not required to be listed. This PI helps to clarify that position. My recommendation is that this should apply to nuts, bolts, washers, rod etc. It would be prudent to require bell joint restraints, retainer glands, megalugs, etc. to be listed for fire protection.

Submitter Information Verification

Submitter Full Name: Peter Schwab
Organization: Wayne Automatic Fire Sprinkler
Street Address:
City:
State:
Zip:
Submittal Date: Mon Jun 10 15:24:39 EDT 2019
Committee: AUT-PRI

Committee Statement

Resolution: See Committee FR 25



Public Input No. 52-NFPA 24-2019 [Section No. 10.6.2.5]

10.6.2.5* Corrosion Resistance.

After installation, rods, nuts, bolts, washers, clamps, and other restraining devices shall be cleaned and thoroughly coated with ~~a bituminous or other~~ an acceptable corrosion-retarding material.

10.6.2.5.1

The requirements of 10.6.2.5 shall not apply to epoxy-coated fittings, valves, glands, or other accessories.

Statement of Problem and Substantiation for Public Input

A bituminous coating is simply an example of a coating. Remove from the body and add it to the annex.

Submitter Information Verification

Submitter Full Name: Peter Schwab

Organization: Wayne Automatic Fire Sprinkler

Street Address:

City:

State:

Zip:

Submittal Date: Mon Jun 10 14:53:19 EDT 2019

Committee: AUT-PRI

Committee Statement

Resolution: FR-25-NFPA 24-2019 PI 52 is part of FR 25 remove word "acceptable"

Statement: Clarifies restrained joint systems

Annex: Moved to a more appropriate section.



Public Input No. 27-NFPA 24-2019 [Section No. 10.7.1.1.1]

10.7.1.1.1

The restraint specified in 10.7.1.1 shall be to natural rock or to ~~suitable~~ piles or piers built on the downhill side of the bell.

Statement of Problem and Substantiation for Public Input

This proposal is to eliminate the word “suitable”, which is not enforceable.

Additionally, the option to restrain the pipe with piles is proposed, as an option to building piers.

Submitter Information Verification

Submitter Full Name: Larry Keeping
Organization: PLC Fire Safety Solutions
Street Address:
City:
State:
Zip:
Submittal Date: Sun Mar 17 13:59:55 EDT 2019
Committee: AUT-PRI

Committee Statement

Resolution: [FR-27-NFPA 24-2019](#)

Statement: This proposal is to eliminate the word “suitable”, which is not enforceable.

Additionally, the option to restrain the pipe with piles is proposed, as an option to building piers.



Public Input No. 28-NFPA 24-2019 [Section No. 10.8.5]

10.8.5

All piping, fittings, valves, and hydrants shall be examined for cracks or other defects while suspended above the trench and lowered into the trench using ~~appropriate~~ equipment designed for such use .

Statement of Problem and Substantiation for Public Input

This proposal is to eliminate the word “appropriate”, which is not enforceable.

Submitter Information Verification

Submitter Full Name: Larry Keeping

Organization: PLC Fire Safety Solutions

Street Address:

City:

State:

Zip:

Submittal Date: Sun Mar 17 14:01:33 EDT 2019

Committee: AUT-PRI

Committee Statement

Resolution: [FR-28-NFPA 24-2019](#)

Statement: This proposal is to eliminate the word “appropriate”, which is not enforceable.



Public Input No. 48-NFPA 24-2019 [Section No. 10.10.1]

A large, empty rectangular box with a thin border, intended for public input or comments.

10.10.1 Approval of Underground Piping.

The installing contractor shall be responsible for the following:

- (1) Notifying the AHJ and the owner's representative of the time and date testing is to be performed
- (2) Performing all required acceptance tests
- (3) Completing and signing the contractor's material and test certificate(s) shown in Figure A. 10.10.1

Move figure 10.10.1 to annex

Figure 10.10.1 Sample of Contractor's Material and Test Certificate for Underground Piping.

Contractor's Material and Test Certificate for Underground Piping	
<p>PROCEDURE Upon completion of work, inspection and tests shall be made by the contractor's representative and witnessed by an owner's representative. All defects shall be corrected and system left in service before contractor's personnel finally leave the job. A certificate shall be filled out and signed by both representatives. Copies shall be prepared for approving authorities, owners, and contractor. It is understood the owner's representative's signature in no way prejudices any claim against contractor for faulty material, poor workmanship, or failure to comply with approving authority's requirements or local ordinances.</p>	
Property name	Date
Property address	
Accepted by approving authorities (names)	
Address	
Plans	Installation conforms to accepted plans <input type="checkbox"/> Yes <input type="checkbox"/> No
	Equipment used is approved <input type="checkbox"/> Yes <input type="checkbox"/> No If no, state deviations
Instructions	Has person in charge of fire equipment been instructed as to location of control valves and care and maintenance of this new equipment? <input type="checkbox"/> Yes <input type="checkbox"/> No If no, explain
	Have copies of appropriate instructions and care and maintenance charts been provided to the owner or owner's representative? <input type="checkbox"/> Yes <input type="checkbox"/> No If no, explain
Location	
Supplies building	
Pipe types and class	
Underground pipe and joints	Pipe conforms to _____ standard <input type="checkbox"/> Yes <input type="checkbox"/> No
	Fittings conform to _____ standard <input type="checkbox"/> Yes <input type="checkbox"/> No If no, explain
	Joints needing anchorage clamped, strapped, or blocked in accordance with _____ standard <input type="checkbox"/> Yes <input type="checkbox"/> No If no, explain
Test description	Flushing: Flow the required rate until water is verified to be clear of debris at outlets such as hydrants and blow-offs. Flush at one of the flow rates as specified in 10.10.2.1.3.
	Hydrostatic: All piping and attached appurtenances subjected to system working pressure shall be hydrostatically tested at 200 psi (13.8 bar) or 50 psi (3.4 bar) in excess of the system working pressure, whichever is greater, and shall maintain that pressure ±5 psi (0.34 bar) for 2 hours. Hydrostatic Testing Allowance: Where additional water is added to the system to maintain the test pressures required by 10.10.2.2.1, the amount of water shall be measured and shall not exceed the limits of the following equation (for metric equation, see 10.10.2.2.6): $L = \frac{SD\sqrt{P}}{148,000}$ L = testing allowance (makeup water), in gallons per hour (lpm) S = length of pipe tested, in feet (m) D = nominal diameter of the pipe, in inches (mm) P = average test pressure during the hydrostatic test, in pounds per square inch (gauge) (bar)
Flushing tests	New underground piping flushed according to standard by (company) <input type="checkbox"/> Yes <input type="checkbox"/> No If no, explain
	How flushing flow was obtained <input type="checkbox"/> Public water <input type="checkbox"/> Tank or reservoir <input type="checkbox"/> Fire pump Through what type opening <input type="checkbox"/> Hydrant butt <input type="checkbox"/> Open pipe Lead-ins flushed according to _____ standard by (company) <input type="checkbox"/> Yes <input type="checkbox"/> No If no, explain How flushing flow was obtained <input type="checkbox"/> Public water <input type="checkbox"/> Tank or reservoir <input type="checkbox"/> Fire pump Through what type opening <input type="checkbox"/> Y connection to flange and spigot <input type="checkbox"/> Open pipe
© 2018 National Fire Protection Association NFPA 24 (p. 1 of 2)	
Hydrostatic test	All new underground piping hydrostatically tested at _____ psi (bar) for _____ hours <input type="checkbox"/> Yes <input type="checkbox"/> No Joints covered <input type="checkbox"/> Yes <input type="checkbox"/> No
Leakage test	Total amount of leakage measured _____ gallons (liters) _____ hours
	Allowable leakage _____ gallons (liters) _____ hours
Forward flow test of backflow preventer	Forward flow test performed in accordance with 10.10.2.5.2 <input type="checkbox"/> Yes <input type="checkbox"/> No
Hydrants	Number installed _____ Type and make _____ All operate satisfactorily <input type="checkbox"/> Yes <input type="checkbox"/> No
Control valves	Water control valves left wide open <input type="checkbox"/> Yes <input type="checkbox"/> No If no, state reason _____ Hose threads of fire department connections and hydrants interchangeable with those of fire department answering alarm <input type="checkbox"/> Yes <input type="checkbox"/> No
Remarks	Date left in service _____
Signatures	Name of installing contractor _____
	Tests witnessed by _____
Signatures	For property owner (signed) _____ Title _____ Date _____
	For installing contractor (signed) _____ Title _____ Date _____
Additional explanation and notes	
© 2018 National Fire Protection Association NFPA 24 (p. 2 of 2)	

Statement of Problem and Substantiation for Public Input

The current test certificates have not been updated for many cycles. It appears that the current code requires

contractors to use the form found in figure 10.10.1 without modification. Several companies have moved to digital forms which are easier to read and edit on a screen and allow for digital signatures. Many of these companies have made modifications to their digital forms to provide various improvements to the current certificate:

1. Added important information found in the acceptance chapter that is not found on the form (for example, backfilling of trench)
2. Reconfiguring the form based on the party responsible for the data entry. The form requires input that is typically supplied by multiple parties. (for example, the designer, the project manager, and the fitter). The portion to be supplied by each party is scattered throughout the document making it difficult to fill out correctly. Usually this form is partially filled out by the designer (material and design criteria), then the project manager provides additional information (welding, O&Ms, etc.), and then the fitter supplies the testing results.
3. Reconfiguring the form based on the natural sequence of the testing. Most systems are hydrostatically tested weeks before the alarms are installed and ready for testing. Most system are trip and alarm tested before owner training is scheduled. Following the natural order makes the form more self-documenting, provides better instruction, and ensures completion.
4. Modify for multiple signatures. There is only one spot on this form for a signature even though multiple activities are covered by these forms which often take place by different people at separate occasions. Often, AHJs and GCs require paperwork to be submitted after each activity, resulting in the submission of incomplete forms, which looks bad and can expose one to liability.
5. A smart, digital form or software package could collect just the relevant information needed for acceptance, reducing the number of blank fields and duplicate entries. Modern software can not only make completing the form easier, but can also distribute the completed form for digital signatures, and archive the certificates in cloud storage.
6. Add additional instruction or legal language. The one-size-fits-all form prevents contractors from including important instruction or legal verbiage that may protect them from future legal action.

By moving this form to the annex, contractors will have the ability to tailor a form to be pertinent to the particular project. (This may be a Task Group project to update and modernize these forms. This concept if accepted needs to be correlated with NFPA 24 and NFPA 13. Similar PI have been submitted to NFPA 13

Related Public Inputs for This Document

Related Input	Relationship
Public Input No. 49-NFPA 24-2019 [New Section after A.10.9.3]	
Public Input No. 50-NFPA 24-2019 [Global Input]	

Submitter Information Verification

Submitter Full Name: Roland Asp
Organization: National Fire Sprinkler Association
Affiliation: on behalf of NFSA Engineering and Standards Committee
Street Address:
City:
State:
Zip:
Submission Date: Fri Jun 07 09:49:41 EDT 2019
Committee: AUT-PRI

Committee Statement

Resolution: [FR-29-NFPA 24-2019](#)

Statement: The current test certificates have not been updated for many cycles. It appears that the current code requires contractors to use the form found in figure 10.10.1 without modification. Several companies have moved to digital forms which are easier to read and edit on a screen and allow for digital signatures. Many of these companies have made modifications to their digital forms to provide various improvements to the current certificate:

1. Added important information found in the acceptance chapter that is not found on the form (for

example, backfilling of trench)

2. Reconfiguring the form based on the party responsible for the data entry. The form requires input that is typically supplied by multiple parties. (for example, the designer, the project manager, and the fitter). The portion to be supplied by each party is scattered throughout the document making it difficult to fill out correctly. Usually this form is partially filled out by the designer (material and design criteria), then the project manager provides additional information (welding, O&Ms, etc.), and then the fitter supplies the testing results.

3. Reconfiguring the form based on the natural sequence of the testing. Most systems are hydrostatically tested weeks before the alarms are installed and ready for testing. Most systems are trip and alarm tested before owner training is scheduled. Following the natural order makes the form more self-documenting, provides better instruction, and ensures completion.

4. Modify for multiple signatures. There is only one spot on this form for a signature even though multiple activities are covered by these forms which often take place by different people at separate occasions. Often, AHJs and GCs require paperwork to be submitted after each activity, resulting in the submission of incomplete forms, which looks bad and can expose one to liability.

5. A smart, digital form or software package could collect just the relevant information needed for acceptance, reducing the number of blank fields and duplicate entries. Modern software can not only make completing the form easier, but can also distribute the completed form for digital signatures, and archive the certificates in cloud storage.

6. Add additional instruction or legal language. The one-size-fits-all form prevents contractors from including important instruction or legal verbiage that may protect them from future legal action.

By moving this form to the annex, contractors will have the ability to tailor a form to be pertinent to the particular project. (This may be a Task Group project to update and modernize these forms.)

This concept if accepted needs to be correlated with NFPA 24 and NFPA 13. Similar PIs have been submitted to NFPA 13



Public Input No. 39-NFPA 24-2019 [Section No. 10.10.2.1.3 [Excluding any Sub-Sections]]

The minimum rate of flow shall be in accordance with Table 10.10.2.1.3.

Table 10.10.2.1.3 Flow Required to Produce Velocity of 10 ft/sec (3.0 m/sec) in Pipes

<u>Nominal Pipe Size</u>						
<u>Flow Rate</u>		<u>Nominal Pipe Size</u>	<u>Flow Rate</u>			
<u>(in.)</u>	<u>(gpm)</u>		<u>(mm)</u>	<u>-</u>	<u>gpm</u>	<u>(L/min)</u>
2	100		50	-	400	380
2½	150		65	-	450	570
3	80 220		75	220	833	
4	390		100	-	390	1500
5	610		125	-	640	2300
6	880		150	-	880	3350
8	1,560		200	-	1560	5900
10	2,440		250	-	2440	9250
12	3,520		300	-	3520	13,300

Statement of Problem and Substantiation for Public Input

To align the format of the table with similar tables in NFPA 20

Related Public Inputs for This Document

Related Input	Relationship
Public Input No. 41-NFPA 24-2019 [New Section after 10.10.2.1.4]	

Submitter Information Verification

Submitter Full Name: Marinus Both
Organization:
Affiliation: Technical Committee on Fire Pumps (NFPA 20)
Street Address:
City:
State:
Zip:
Submission Date: Tue Apr 16 08:46:39 EDT 2019
Committee: AUT-PRI

Committee Statement

Resolution: FR-30-NFPA 24-2019
Statement: To align the format of the table with similar tables in NFPA 20



Public Input No. 29-NFPA 24-2019 [Section No. 10.10.2.1.3.1]

10.10.2.1.3.1

Where the flow rates established in Table 10.10.2.1.3 are not attainable, the maximum allowable flow rate available at the minimum allowable residual pressure to the system shall be acceptable.

Statement of Problem and Substantiation for Public Input

This proposal is offered to clarify the acceptable flow rate if the values from Table 10.10.2.1.3 cannot be obtained. Many municipalities do not allow residual pressures to fall below 20 psi, so while more flow might be “available” at lesser pressures, the “allowable” flow rate would be somewhat less.

Submitter Information Verification

Submitter Full Name: Larry Keeping
Organization: PLC Fire Safety Solutions
Street Address:
City:
State:
Zip:
Submission Date: Sun Mar 17 14:05:01 EDT 2019
Committee: AUT-PRI

Committee Statement

Resolution: FR-31-NFPA 24-

Statement: This proposal is offered to clarify the acceptable flow rate if the values from Table 10.10.2.1.3 cannot be obtained. Many municipalities do not allow residual pressures to fall below 20 psi, so while more flow might be “available” at lesser pressures, the “allowable” flow rate would be somewhat less.



Public Input No. 4-NFPA 24-2018 [Section No. 10.10.2.1.3.1]

10.10.2.1.3.1

Where the flow rates established in Table 10.10.2.1.3 are not attainable, the maximum flow rate available to the system shall be acceptable.

10.10.2.1.3.2

In lieu of flushing with the waterflow rates prescribed in 10.10.2.1.3 and 10.10.2.1.3.1 water main swabbing of the piping, by the forceful introduction of a large sponge through the pipe, to remove debris, shall be permitted.

10.10.2.1.3.2.1

Water main swabbing shall be repeated, as necessary, until the last sponge that has fully penetrated the pipe is clean and the discharge water is clear.

Additional Proposed Changes

File Name	Description	Approved
NFPA_24_PC12.pdf	NFPA_24_PC12	

Statement of Problem and Substantiation for Public Input

NOTE: This Public Input appeared as "Reject but Hold" in Public Comment No. 12 of the (A2018) Second Draft Report for NFPA 24 and per the Regs. at 4.4.8.3.1.

Water conservation has become a very large issue in many regions and the water flow rates prescribed by the standard are very high and often not permitted by the municipal authority. Water main swabbing is an excellent alternative to the current flushing requirements. It is more obtrusive than flushing and thus more effective and can use significantly less water to achieve the desired results.

Submitter Information Verification

Submitter Full Name: TC on AUT-PRI
Organization: NFPA
Street Address:
City:
State:
Zip:
Submission Date: Mon Oct 29 13:33:16 EDT 2018
Committee: AUT-PRI

Committee Statement

Resolution: FR-31-NFPA 24-

Statement: This proposal is offered to clarify the acceptable flow rate if the values from Table 10.10.2.1.3 cannot be obtained. Many municipalities do not allow residual pressures to fall below 20 psi, so while more flow might be "available" at lesser pressures, the "allowable" flow rate would be somewhat less.



Public Input No. 41-NFPA 24-2019 [New Section after 10.10.2.1.4]

10.10.2.1.4*

The minimum rate of flow shall be in accordance with Table 10.10.2.1.4. for underground piping supplying one or more fire pumps directly, or at the hydraulically calculated water demand rate of the system, whichever is greater.

Table 10.10.2.1.4 Minimum Flow Rates for Flushing Underground Piping supplying Fire Pump(s)

<u>Nominal Pipe Size</u>	<u>Flow rate</u>	<u>Nominal Pipe Size</u>	<u>Flow Rate</u>
<u>∅</u>	<u>∅</u>	<u>∅</u>	<u>∅</u>
<u>(in.)</u>	<u>(gpm)</u>	<u>(mm)</u>	<u>(L/min)</u>
<u>2</u>	<u>150</u>	<u>50</u>	<u>570</u>
<u>2 ½</u>	<u>230</u>	<u>65</u>	<u>870</u>
<u>3</u>	<u>330</u>	<u>75</u>	<u>1,250</u>
<u>3 ½</u>	<u>450</u>	<u>85</u>	<u>1,710</u>
<u>4</u>	<u>590</u>	<u>100</u>	<u>2,240</u>
<u>5</u>	<u>920</u>	<u>125</u>	<u>3,490</u>
<u>6</u>	<u>1,360</u>	<u>150</u>	<u>5,150</u>
<u>8</u>	<u>2,350</u>	<u>200</u>	<u>8,900</u>
<u>10</u>	<u>3,670</u>	<u>250</u>	<u>13,900</u>
<u>12</u>	<u>5,290</u>	<u>300</u>	<u>20,100</u>
<u>14</u>	<u>7,200</u>	<u>350</u>	<u>27,300</u>
<u>16</u>	<u>9,400</u>	<u>400</u>	<u>35,600</u>

10.10.2.1.4.1

Where the maximum flow available from the water supply cannot provide the flow rate provided in Table 10.10.2.1.4, the flushing flow rate shall be equal to or greater than 150 percent of rated flow of the connected fire pump.

10.10.2.1.4.2

Where the maximum flow available from the water supply cannot provide a flow of 150 percent of the rated flow of the pump, the flushing flow rate shall be the greater of 100 percent of rated flow of the connected fire pump or the maximum flow demand of the fire protection system.

10.10.2.1.4.3

A reduced flushing flow capacity in accordance with 10.10.2.1.4.2 shall constitute an acceptable test, provided that the flow rate is as much as can be safely achieved and it exceeds the fire protection system design flow rate.

Statement of Problem and Substantiation for Public Input

The addition of this section would include the requirement to flush underground piping adequately when used to supply fire pumps, aligning the requirements in NFPA 24 with those in NFPA 20 for fire pump suction piping.

Related Public Inputs for This Document

Related Input	Relationship
Public Input No. 39-NFPA 24-2019 [Section No. 10.10.2.1.3 [Excluding any Sub-Sections]]	Tables in both section to be similar in layout

Submitter Information Verification

Submitter Full Name: Marinus Both
Organization:
Affiliation: Technical Committee on Fire Pumps (NFPA 20)
Street Address:
City:
State:
Zip:
Submittal Date: Tue Apr 16 09:04:18 EDT 2019
Committee: AUT-PRI

Committee Statement

Resolution: [FR-32-NFPA 24-2019 PI 41](#) is included in [FR32](#)

Statement: This proposal is for a new Section 10.10.2.1.4 for an alternate cleaning procedure, in lieu of the tradition flushing. Water conservation has become a very large issue in many regions and the water flow rates prescribed by the standard are very high and often not permitted by the municipal authority. Water main swabbing is an excellent alternative to the current flushing requirements. It is more obtrusive than flushing and thus more effective and can use significantly less water to achieve the desired results.

Please note, this is similar to Public Comment 12, from the previous revision cycle, which was held, because at that time it was considered to be new material.

This proposal is also to eliminate the word "proper" from the existing Section 10.10.2.1.4 (now proposed as 10.10.2.1.5), which is not enforceable, and to provide additional text to help clarify what is meant by "disposal".



Public Input No. 30-NFPA 24-2019 [Section No. 10.10.2.1.4]

10.10.2.1.4

In lieu of flushing with the waterflow rates prescribed in 10.10.2.1.3 and 10.10.2.1.3.1 water main cleaning of the piping, by the forceful introduction of polyurethane foam swabs through the pipe, shall be permitted.

10.10.2.1.4.1

Water main swabbing shall be repeated, as necessary, until the last sponge that has fully penetrated the pipe is clean and the discharge water is clear.

10.10.2.1.5

Provision shall be made for the proper disposal of water used for flushing or testing to minimize any water damage caused by the discharge .

Additional Proposed Changes

File Name	Description	Approved
Water_Main_Swabbing_-_Handout.pdf	Presentation on Water Main Swabbing	

Statement of Problem and Substantiation for Public Input

This proposal is for a new Section 10.10.2.1.4 for an alternate cleaning procedure, in lieu of the tradition flushing. Water conservation has become a very large issue in many regions and the water flow rates prescribed by the standard are very high and often not permitted by the municipal authority. Water main swabbing is an excellent alternative to the current flushing requirements. It is more obtrusive than flushing and thus more effective and can use significantly less water to achieve the desired results.

Please note, this is similar to Public Comment 12, from the previous revision cycle, which was held, because at that time it was considered to be new material.

This proposal is also to eliminate the word "proper" from the existing Section 10.10.2.1.4 (now proposed as 10.10.2.1.5), which is not enforceable, and to provide additional text to help clarify what is meant by "disposal".

Submitter Information Verification

Submitter Full Name: Larry Keeping
Organization: PLC Fire Safety Solutions
Street Address:
City:
State:
Zip:
Submittal Date: Sun Mar 17 14:07:39 EDT 2019
Committee: AUT-PRI

Committee Statement

Resolution: FR-32-NFPA 24-2019 PI 41 is included in FR32

Statement: This proposal is for a new Section 10.10.2.1.4 for an alternate cleaning procedure, in lieu of the tradition flushing. Water conservation has become a very large issue in many regions and the water flow rates prescribed by the standard are very high and often not permitted by the municipal authority. Water main swabbing is an excellent alternative to the current flushing requirements. It is more obtrusive than flushing and thus more effective and can use significantly less water to achieve the desired results.

Please note, this is similar to Public Comment 12, from the previous revision cycle, which was held, because at that time it was considered to be new material.

This proposal is also to eliminate the word “proper” from the existing Section 10.10.2.1.4 (now proposed as 10.10.2.1.5), which is not enforceable, and to provide additional text to help clarify what is meant by “disposal”.



Public Input No. 31-NFPA 24-2019 [Section No. 10.10.2.2.2]

10.10.2.2.2

~~Acceptable~~ Successful test results shall be determined by indication of ~~either~~ a pressure loss less than gauge pressure of 5 psi ~~or~~ and by no visual leakage.

Statement of Problem and Substantiation for Public Input

This proposal is to eliminate the word “acceptable”, which is not enforceable and not permitted by the Manual of Style.

Additionally, the word “or” was changed to “and” because both visual leakage and a pressure loss of more than 5 psi are indications of an unsuccessful test. If the pressure drops more than 5 psi, the test fails. If water can be visually seen to be leaking, the test fails.

Submitter Information Verification

Submitter Full Name: Larry Keeping

Organization: PLC Fire Safety Solutions

Street Address:

City:

State:

Zip:

Submittal Date: Sun Mar 17 14:11:42 EDT 2019

Committee: AUT-PRI

Committee Statement

Resolution: The option for visible leakage is needed.



Public Input No. 32-NFPA 24-2019 [Sections 10.10.2.4.2, 10.10.2.4.3]

Sections 10.10.2.4.2, 10.10.2.4.3

10.10.2.4.2

Dry barrel hydrants shall be checked for proper drainage.

10.10.2.4.3

All control valves shall be fully closed and opened under system water pressure to ensure proper operation.

Statement of Problem and Substantiation for Public Input

This proposal is to eliminate the word “proper”, which is not enforceable.

Submitter Information Verification

Submitter Full Name: Larry Keeping

Organization: PLC Fire Safety Solutions

Street Address:

City:

State:

Zip:

Submittal Date: Sun Mar 17 14:14:33 EDT 2019

Committee: AUT-PRI

Committee Statement

Resolution: FR-34-NFPA 24-2019 PI 7 is resolved - submitter did not provide proposed language or means to complete the intended task.

Statement: This proposal is to eliminate the word “proper”, which is not enforceable.



Public Input No. 7-NFPA 24-2018 [New Section after 10.10.2.4.3]

TITLE OF NEW CONTENT

Type your content here ...

Operational Test

New requirement: Positive isolation downstream of each control valve shall be verified by inspection.

Statement of Problem and Substantiation for Public Input

Control valves are installed to isolate the water supply to the downstream section of pipe. To ensure that the valve provides it's intended service, a physical inspection downstream of the control valve is warranted. Only operating the control valve from an open to shut position and returning to the open position doesn't ensure the intent of the control valve. The valve can be operated to what the operator thinks is the shut position and then re-opened only to find out later that the seat of the control valve is messed up or misaligned and the control valve cannot isolated the water supply as intended.

Submitter Information Verification

Submitter Full Name: Tom Christman
Organization: [Not Specified] Self-employed
Affiliation: None
Street Address:
City:
State:
Zip:
Submission Date: Mon Nov 05 06:43:05 EST 2018
Committee: AUT-PRI

Committee Statement

Resolution: [FR-34-NFPA 24-2019 PI 7 is resolved - submitter did not provide proposed language or means to complete the intended task.](#)

Statement: This proposal is to eliminate the word "proper", which is not enforceable.



Public Input No. 33-NFPA 24-2019 [Section No. 10.10.2.5.1]

10.10.2.5.1

The backflow prevention assembly shall be forward flow tested to ensure proper operation . [verify that the backflow preventer will open to allow water to extinguish a fire](#) .

Statement of Problem and Substantiation for Public Input

This proposal is to eliminate the word “proper”, which is not enforceable.

The additional text is proposed, to clarify the goal of the forward flow test.

Submitter Information Verification

Submitter Full Name: Larry Keeping
Organization: PLC Fire Safety Solutions
Street Address:
City:
State:
Zip:
Submittal Date: Sun Mar 17 14:16:43 EDT 2019
Committee: AUT-PRI

Committee Statement

Resolution: [FR-35-NFPA 24-2019](#)

Statement: This proposal is to eliminate the word “proper”, which is not enforceable.

The additional text is proposed, to clarify the goal of the forward flow test.



Public Input No. 34-NFPA 24-2019 [New Section after 11.2]

TITLE OF NEW CONTENT

[11.3 Hydraulic calculations of system piping shall be in accordance with the procedures of NFPA 13.](#)

Statement of Problem and Substantiation for Public Input

This proposal offered to provide additional instruction concerning hydraulic calculation procedures. Currently NFPA 24 does not contain any information concerning C-factors, fitting equivalents, adjustments, etc.

Submitter Information Verification

Submitter Full Name: Larry Keeping
Organization: PLC Fire Safety Solutions
Street Address:
City:
State:
Zip:
Submission Date: Sun Mar 17 14:20:04 EDT 2019
Committee: AUT-PRI

Committee Statement

Resolution: [FR-36-NFPA 24-2019](#)

Statement: This proposal offered to provide additional instruction concerning hydraulic calculation procedures. Currently NFPA 24 does not contain any information concerning C-factors, fitting equivalents, adjustments, etc.



Public Input No. 35-NFPA 24-2019 [Section No. 13.3]

13.3 Mains Supplying Fire Protection Systems.

The size of private fire service mains supplying fire protection systems shall be approved by the authority having jurisdiction, and based on the following factors- ~~shall be considered~~ :

- (1) Construction and occupancy of the plant
- (2) Fire flow and pressure of the water required
- (3) Adequacy of the water supply

Statement of Problem and Substantiation for Public Input

This proposal is to eliminate the word “considered”, which is not enforceable.

Submitter Information Verification

Submitter Full Name: Larry Keeping
Organization: PLC Fire Safety Solutions
Street Address:
City:
State:
Zip:
Submittal Date: Sun Mar 17 14:22:56 EDT 2019
Committee: AUT-PRI

Committee Statement

Resolution: [FR-37-NFPA 24-2019](#)

Statement: This proposal is to eliminate the word “considered”, which is not enforceable.



Public Input No. 36-NFPA 24-2019 [Section No. 14.1]

14.1 General.

A private fire service main and its appurtenances installed in accordance with this standard shall be properly inspected, tested, and maintained in accordance with NFPA 25 ~~to provide at least the same level of performance and protection as designed~~ [ensure the system continues to provide a reasonable degree of protection for life and property from fire](#) .

Statement of Problem and Substantiation for Public Input

This proposal is to eliminate the word “properly”, which is not enforceable.

This proposal also suggests revised wording, more in line with the Purpose of NFPA 25, since that standard does not endeavor to verify the adequacy of the design of the system. As explained in Section A.1.1.3.1 of NFPA 25: “The requirement to evaluate the adequacy of the design of the installed system or the capability of the fire protection system to protect the building or its contents, is not a part of the periodic inspection, testing, and maintenance requirements of this standard.”

Submitter Information Verification

Submitter Full Name: Larry Keeping
Organization: PLC Fire Safety Solutions
Street Address:
City:
State:
Zip:
Submittal Date: Sun Mar 17 14:27:15 EDT 2019
Committee: AUT-PRI

Committee Statement

Resolution: [FR-38-NFPA 24-2019](#)

Statement: This proposal is to eliminate the word “properly”, which is not enforceable.

This proposal also suggests revised wording, more in line with the Purpose of NFPA 25, since that standard does not endeavor to verify the adequacy of the design of the system. As explained in Section A.1.1.3.1 of NFPA 25: “The requirement to evaluate the adequacy of the design of the installed system or the capability of the fire protection system to protect the building or its contents, is not a part of the periodic inspection, testing, and maintenance requirements of this standard.”



Public Input No. 49-NFPA 24-2019 [New Section after A.10.9.3]

Figure A.10.10.1 Sample of Contractor's Material and Test Certificate for Underground Piping.

Move Figure 10.10.1 to Annex...

Statement of Problem and Substantiation for Public Input

The current test certificates have not been updated for many cycles. It appears that the current code requires contractors to use the form found in figure 10.10.1 without modification. Several companies have moved to digital forms which are easier to read and edit on a screen and allow for digital signatures. Many of these companies have made modifications to their digital forms to provide various improvements to the current certificate:

1. Added important information found in the acceptance chapter that is not found on the form (for example, backfilling of trench)
2. Reconfiguring the form based on the party responsible for the data entry. The form requires input that is typically supplied by multiple parties. (for example, the designer, the project manager, and the fitter). The portion to be supplied by each party is scattered throughout the document making it difficult to fill out correctly. Usually this form is partially filled out by the designer (material and design criteria), then the project manager provides additional information (welding, O&Ms, etc.), and then the fitter supplies the testing results.
3. Reconfiguring the form based on the natural sequence of the testing. Most systems are hydrostatically tested weeks before the alarms are installed and ready for testing. Most system are trip and alarm tested before owner training is scheduled. Following the natural order makes the form more self-documenting, provides better instruction, and ensures completion.
4. Modify for multiple signatures. There is only one spot on this form for a signature even though multiple activities are covered by these forms which often take place by different people at separate occasions. Often, AHJs and GCs require paperwork to be submitted after each activity, resulting in the submission of incomplete forms, which looks bad and can expose one to liability.
5. A smart, digital form or software package could collect just the relevant information needed for acceptance, reducing the number of blank fields and duplicate entries. Modern software can not only make completing the form easier, but can also distribute the completed form for digital signatures, and archive the certificates in cloud storage.
6. Add additional instruction or legal language. The one-size-fits-all form prevents contractors from including important instruction or legal verbiage that may protect them from future legal action.

By moving this form to the annex, contractors will have the ability to tailor a form to be pertinent to the particular project. (This may be a Task Group project to update and modernize these forms.

This concept if accepted needs to be correlated with NFPA 24 and NFPA 13. Similar PI have been submitted to NFPA 13

Submitter Information Verification

Related Public Inputs for This Document

Related Input	Relationship
Public Input No. 48-NFPA 24-2019 [Section No. 10.10.1]	related

Submitter Information Verification

Submitter Full Name: Roland Asp

Organization: National Fire Sprinkler Association

Affiliation: on behalf of NFSA Engineering and Standards Committee

Street Address:

City:

State:

Zip:

Submission Date: Fri Jun 07 10:01:03 EDT 2019

Committee: AUT-PRI

Committee Statement

Resolution: See action on PI 50