



First Revision No. 18-NFPA 13E-2018 [Global Input]

This revision will reorganize the following chapters:

Chapter 4, General: Includes all items that apply to sprinkler and standpipe systems

Chapter 5, Properties Protected by Sprinkler Systems: Includes all items specific to sprinkler systems and exterior exposure sprinkler systems

Chapter 6, Properties Protected by Standpipe Systems: Includes all items specific to manual and automatic standpipe systems.

All other chapters remain in the same format as the 2015 edition

See attached for reorganized changes to Chapters 4, 5, and 6.

Supplemental Information

<u>File Name</u>	<u>Description</u>	<u>Approved</u>
13E_Annex_A_-_reorg_w_TC.docx	Annex A with Track Changes	
13E_Chapter_4_-_reorg_-_clean.docx	Chapter 4 - clean text	
13E_Chapter_5_-_reorg_-_clean.docx	Chapter 5 - clean text	
13E_Chapter_6_-_reorg_clean.docx	Chapter 6 - clean text	
13E_Move_tracking.xlsx	Excel spreadsheet showing new location of all main body text and figures from Chps 3, 4, 5, Annex A, and new locations of FR/PI	

Submitter Information Verification

Submitter Full Name: Jeremy Souza

Organization: NFPA

Street Address:

City:

State:

Zip:

Submission Date: Mon Apr 09 13:56:13 EDT 2018

Committee Statement

Committee Statement: The Committee has chosen to reorganize Chapters 4, 5, and 6 in order to better group similar items, and remove redundant text that is repeated through those chapters.

Response Message:



Annex A Explanatory Material

Annex A is not a part of the recommendations of this NFPA document but is included for informational purposes only. This annex contains explanatory material, numbered to correspond with the applicable text paragraphs.

A.3.2.1 Approved.

The National Fire Protection Association does not approve, inspect, or certify any installations, procedures, equipment, or materials; nor does it approve or evaluate testing laboratories. In determining the acceptability of installations, procedures, equipment, or materials, the authority having jurisdiction may base acceptance on compliance with NFPA or other appropriate standards. In the absence of such standards, said authority may require evidence of proper installation, procedure, or use. The authority having jurisdiction may also refer to the listings or labeling practices of an organization that is concerned with product evaluations and is thus in a position to determine compliance with appropriate standards for the current production of listed items.

A.3.2.2 Authority Having Jurisdiction (AHJ).

The phrase “authority having jurisdiction,” or its acronym AHJ, is used in NFPA documents in a broad manner, since jurisdictions and approval agencies vary, as do their responsibilities. Where public safety is primary, the authority having jurisdiction may be a federal, state, local, or other regional department or individual such as a fire chief; fire marshal; chief of a fire prevention bureau, labor department, or health department; building official; electrical inspector; or others having statutory authority. For insurance purposes, an insurance inspection department, rating bureau, or other insurance company representative may be the authority having jurisdiction. In many circumstances, the property owner or his or her designated agent assumes the role of the authority having jurisdiction; at government installations, the commanding officer or departmental official may be the authority having jurisdiction.

A.3.2.4 Listed.

The means for identifying listed equipment may vary for each organization concerned with product evaluation; some organizations do not recognize equipment as listed unless it is also labeled. The authority having jurisdiction should utilize the system employed by the listing organization to identify a listed product.

A.3.3.2.1 Private Fire Hydrant.

Where connected to a public water system, private hydrants are supplied by a private service main that begins at the point designated by the AHJ, usually at a manually operated valve near the property line.

A.3.3.4 Sprinkler System.

As applied to the definition of a sprinkler system, each system riser serving a portion of a single floor of a facility or where individual floor control valves are used in a multistory building should be considered a separate sprinkler system. Multiple sprinkler systems can be supplied by a common supply main. [13, 2016]

A.3.3.5 Standpipe System.

This arrangement is accomplished by means of connections to water supply systems or by means of pumps, tanks, and other equipment necessary to provide an adequate supply of water to the hose connections. [14, 2016]

A.4.1

Records of the National Fire Protection Association and other fire protection associations around the world clearly indicate the highly effective performance of automatic sprinkler systems.

A.4.2

Figure A.4.2 shows a typical layout of water supply and sprinkler system features serving a building.

Figure A.4.2 A Typical Layout of a Water Supply System for Automatic Sprinkler Systems.

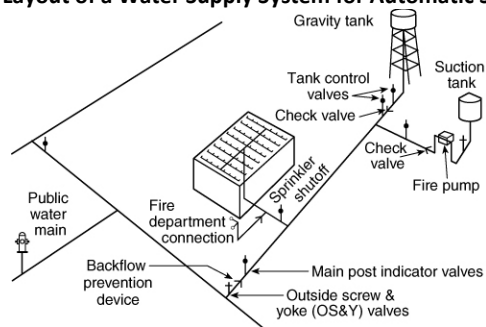

A.4.2.1(3)

The diagram in Figure A.4.2 indicates two types of valves that fire department personnel need to understand the function of and be able to recognize and locate in emergencies. These are the outside screw and yoke valves that control the flow of water for the entire system from various points and the post indicator valves that control the flow of water to specific mains and sections of the system. These two types of valves are shown in Figure A.4.2.1(3).

Figure A.4.2.1(3) Two Types of Control Valves That Fire Department Personnel Should Readily Recognize and Understand the Purposes of.

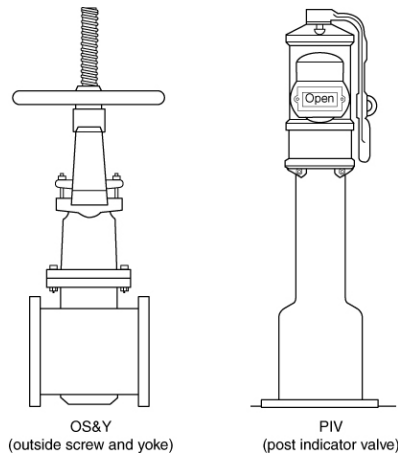

~~A.6.1.3~~

~~The procedure for fire department pre-incident planning for properties protected by standpipe systems is in many ways similar to that for automatic sprinkler systems.~~

~~A.6.1.6—A.4.2.3.3~~

Hose outlets on manual standpipes should be tested annually by opening and closing the valve and checking for proper operation and good working condition. Note that pressure-restricting devices (PRD) and pressure-reducing valves (PRV) are generally used only on automatic standpipe systems and are typically not installed on manual standpipe outlets.

~~A.6.6—A.4.2.3.4~~

NFPA 20 might require pressure-relief devices to be installed in the standpipe to protect the standpipe from over pressurization.

When pressure-relief devices are required, they should be located on the discharge side of the fire pump and before the check valve. A pressure-relief device should not limit the standpipe pressure when the system demand is supplied through the fire department connection. The intent is to allow the fire department to pump additional pressure above system demand into the fire department connection if necessary. It is recommended to pump no more than 50 psi (3.4 bar) above system demand to avoid over-pressurizing the standpipe beyond its required test pressure and design limitations.

NFPA 14 requires the use of pressure-reducing valves to limit residual and static pressure at the outlet of the hose connection to no more than 175 psi (12.1 bar). Prior to 1993, pressure-reducing valves were required to limit residual and static pressure at the outlet of the hose connection to no more than 100 psi (6.9 bar).

Pressure-restricting devices (PRD) limit pressure only when water is flowing. Pressure-restricting devices attached to the discharge threads of existing standpipe outlet valves can be removed to increase pressure and flow when necessary. Standpipe outlet valves can have

removable clips or stops that limit how far the valve can be opened. Removing the clips or stops should allow the valves to be fully opened and no longer restricting pressure and flow. Pressure-reducing valves regulate pressure under both flowing and static conditions. Pressure-reducing valves reduce a higher inlet pressure to a lower outlet pressure, which is a ratio of the inlet to outlet pressure. A valve with an inlet pressure of 300 psi (20.7 bar) with an outlet pressure of 100 psi (6.9 bar) would have a pressure-reducing ratio of 3:1. Pumping an additional 50 psi (3.4 bar) above system demand into the fire department connection would result in 350 psi (24.1 bar) to the inlet side of the pressure-reducing valve with approximately 117 psi (8.1 bar) on the discharge side.

Pressure-reducing valves are installed on automatic standpipe outlets and sprinkler connections on combined systems. Pressure-reducing valves should not be removed from the standpipe while the system is under pressure. If a pressure-reducing valve was removed, the pipe threads at the standpipe connection would not be compatible with fire hose threads.

~~A.5.3.1~~—~~A.4.3.1~~

Alternative sources of water meeting the requirements of NFPA 1142 can be used to supplement fire department water sources for supplying standpipe and sprinkler systems.

~~A.6.2.1~~—~~A.4.3.3~~

Manual wet-pipe systems supplied only by fire department connections are also used.

~~A.6.5.1~~—~~A.4.3.6.1~~

NFPA 14 requires a minimum residual pressure of 100 psi (6.9 bar) at any 2½ in. (63.5 mm) standpipe outlet and also requires that pressure-reducing valves be used anytime an outlet pressure to a hose connection is greater than 175 psi (12.1 bar). Normal expected outlet pressure ranges on these systems could be from 100 psi (6.9 bar) to 175 psi (12.1 bar). Connecting an in-line pressure gauge between the hose line and the standpipe outlet on the floor below the fire floor allows a fire fighter stationed at the standpipe to accurately set and maintain the correct pressure to a flowing hose line by gating down a higher outlet pressure. A 100 psi (6.9 bar) residual outlet pressure would support approximately 500 ft (152 m) of 2½ in. (63.5 mm) hose line with a 50 psi (3.4 bar) nozzle flowing 250 gpm (946 L/m). This would place a maximum of 475 ft (145 m) of working hose line on the fire floor when connected to the standpipe outlet one floor below the fire floor.

Prior to 1993, NFPA 14 required a minimum residual pressure of 65 psi (4.5 bar) at 2½ in. (63.5 mm) standpipe outlets and required pressure-reducing valves when standpipe outlet pressures at hose connections were greater than 100 psi (6.9 bar). Normal expected outlet pressures on systems built to pre-1993 standards could be from 65 psi (4.5 bar) to 100 psi (6.9 bar). A 65 psi (4.5 bar) residual outlet pressure would support 150 ft (45 m) of 2½ in. (63.5 mm) hose line with a 50 psi (3.4 bar) nozzle flowing 250 gpm (946 L/m). When connected to the standpipe outlet one floor below the fire floor, this places a maximum of 125 ft (38 m) of hose line on the fire floor. Connecting additional lengths of 2½ in. (63.5 mm) hose line can increase the friction loss of the hose line and reduce the flow and reach of the nozzle.

A 65 psi (4.5 bar) residual outlet pressure would not support traditional hotel bundles or high rise bundles utilizing 1¾ in. (44.4 mm) hose line and 75 psi (5.2 bar) or 100 psi (6.9 bar) nozzles. A 100 psi (6.9 bar) residual outlet pressure would be able to support only 100 ft (30 m) of 1¾ in. (44.4 mm) hose line with a 75 psi (5.2 bar) nozzle flowing 150 gpm (568 L/m). This would place a maximum of 75 ft (23 m) of working hose line on the fire floor. A 100 psi (6.9 bar) residual outlet pressure would not support the use of 100 psi (6.9 bar) nozzles.

Automatic or constant-pressure nozzles are not recommended for use on automatic standpipes. Potential low system pressures insufficient to supply the required nozzle pressure can cause the nozzle orifice to constrict, which greatly reduces the flow and reach of the hose line.

Combination nozzles with adjustable patterns are easily fouled by standpipe debris, which can result in a partial or complete blockage. Smooth-bore nozzles are less prone to blockage from standpipe debris and generally function in a predictable manner when under-pressurized. Attaching a 2½ in. (63.5 mm) by 2½ in. (63.5 mm) gated wye to a standpipe outlet to allow the connection of two 2½ in. (63.5 mm), or large diameter hose lines is not always a recommended practice because 2½ in. (63.5 mm) standpipe outlets are only required to flow 250 gpm (946 L/m) and might not support flowing two handlines simultaneously. Pressure-reducing valves (PRV) connected to 2½ in. (63.5 mm) standpipe outlets are generally sized for 250 gpm (946 L/m) to 400 gpm (1514 L/m) and should generally not provide adequate flow for two large diameter hose lines. Initial actions should be to connect a single large diameter hose line to each standpipe hose connection. Additional hose lines can be connected to standpipe hose connections on lower floors.

A.6.5.2—A.4.3.6.2

NFPA 14 requires signage at the fire department connection to indicate the pressure required to be pumped into the fire department connection to supply the automatic standpipe system demand. Signage is also required to identify the type of standpipe, whether it is part of a combined sprinkler system, and the location of the standpipe services.

Fire departments should have knowledge of all system demand pressures required to support all of the automatic standpipe systems in their jurisdictions. Hose lines used to connect a hydrant to the intake of a pumper should have a working pressure rating equal to or greater than the available hydrant pressure. Hose lines used to connect the discharge of a pumper to the fire department connection on an automatic standpipe should have a working pressure rating equal to or greater than the system demand pressure of the automatic standpipe system. NFPA 14 limits automatic standpipe pressures to no more than 350 psi (24.1 bar). Fire department pumpers should be configured to provide the highest system demand pressure for automatic standpipes in their jurisdictions. An accepted rule of thumb is one pumper per 150 psi (10.3 bar) of system demand pressure required. The configuration of pumpers should also provide the required flow into the fire department connection.

A fire department pumper with a two-stage pump in volume mode connected to a hydrant with 50 psi (3.4 bar) residual pressure can deliver 200 psi (13.8 bar) into an automatic standpipe while maximizing the pump's flow capacity. [150 psi + 50 psi = 200 psi (10.3 bar + 3.4 bar = 13.8 bar)]. At a net discharge pressure of 150 psi (10.3 bar), the pump impeller can deliver its maximum flow capacity plus additional flow from the incoming hydrant pressure. Using a single

pumper to supply pressure into systems requiring pressures greater than 200 psi (13.8 bar) can reduce the flow capacity of the pump when the pump's net discharge pressure exceeds 150 psi (10.3 bar). Operating a two-stage pump in pressure mode allows the pump to generate higher discharge pressures at lower engine speeds but limits the pump to half its rated flow capacity. Configuring two pumpers in series on a hydrant with 50 psi (3.4 bar) residual pressure will allow the pumpers to split the work load and deliver 350 psi (24.1 bar) into the standpipe [150 psi + 150 psi + 50 psi = 350 psi (10.3 bar + 10.3 bar + 3.4 bar = 24.1 bar)]. In a series configuration, both pumps can remain in volume mode and operate at the optimum net discharge pressure to maximize the flow capacity of both engines into the standpipe. Standpipes that are part of a combined system are required to be at least 6 in. (152.4 mm) in size. When supplying water at the system demand pressure into the fire department connection, fire department pumpers with a higher flow capacity than the standpipe fire pump can potentially increase the flow capacity of the standpipe.

~~A.6.5.3~~—A.4.3.6.3

The fire pump motor is paired with an impeller that is sized to provide the standpipe system's required water flow capacity. Fire department connections are required to be sized to provide one 2½ in. (63.5 mm) inlet for every 250 gpm (946 L/m) of standpipe capacity. An automatic standpipe designed to flow 750 gpm (2839 L/m) would be supplied by a 750 gpm (2839 L/m) fire pump and would have three 2½ in. (63.5 mm) inlets at the fire department connection. Fire departments should pump into automatic standpipes at the system demand pressure regardless of the fire location.

A standpipe supplied at one system pressure should have incrementally higher pressures at each floor below the highest standpipe sprinkler connection by virtue of diminishing head pressure.

Pressure-reducing valves connected to the standpipe utilize water pressure inside the valve body to manipulate an internal piston that opens and closes to deliver the intended discharge pressure and flow. Pressure-reducing valves are designed to operate from the specific standpipe pressure that is present at each floor while the standpipe is being supplied at the system demand pressure.

When an automatic standpipe fire pump is not working and the fire department has taken over supplying water into the standpipe, pumping to the fire floor would not provide the system demand inlet pressure required for the pressure-reducing valves to function. This would produce significantly low discharge pressures and reduced flow from the pressure-reducing valve.

Automatic standpipes that are combined systems should have sprinkler connections to the standpipe at each floor. The standpipe pressure at each floor could require a pressure-reducing valve to be installed at the sprinkler connection to the standpipe, reducing the standpipe pressure down to the required sprinkler system operating pressure.

In an automatic standpipe system design where pressure-reducing valves are not installed on the standpipe outlets for hose connections, any sprinkler connection that utilizes a pressure-reducing valve could still require the standpipe to be supplied at system demand for the pressure-reducing valve to operate correctly.

It is possible for the fire department to pump to the fire floor when standpipe outlets for hose connections do not have pressure-reducing valves installed. However, the calculated pump discharge pressure just to the fire floor or highest operating hose line would not be sufficient to allow the sprinkler system pressure-reducing valves to operate correctly. Unless the fire location was at the top of the standpipe and the calculated discharge pressure was equal to the system demand, pumping to the fire floor could effectively disable all of the sprinklers connected to the standpipe on or above the fire floor. It is recommended practice to keep the sprinklers functioning on and above the fire floor as well as throughout the rest of the building whenever possible.

The system demand pressure should always be pumped when taking over automatic standpipe systems to allow all of the pressure-regulating and distribution components to operate correctly. This provides the designed working pressure and flow to any outlet or sprinkler head in the system.

~~A.4.3.4~~ ~~A.5.1.4~~

Fire department pumpers should only be connected to public and private fire hydrants that have a confirmed capability to provide adequate water quantities and pressures to supply the designed water supply needs for an automatic sprinkler or standpipe system.

Commented [SJ1]: FR 13 / PI 5

It might be necessary to alter the pressure of 150 psi (10.3 bar) to properly supply foam-water sprinkler systems, hydraulically calculated sprinkler systems, or high rise systems. Performance of certain systems,

such as foam-water sprinkler systems or hydraulically calculated sprinkler systems, can be adversely affected by increased pressures beyond the design limits of the system.

The 150 psi (10.3 bar) is a starting point for the initial connection. The working pressure of sprinkler system aboveground components are a minimum 175 psi (12.1 bar) and will have been hydrostatically tested at a minimum of 200 psi (14 bar). The pump operator should look for a sign at the fire department connection indicating the required pressure. For a sprinkler system, the purpose of the fire department connection is to only supplement the pressure. On combination systems (sprinkler system and standpipe system), there is a sign required to indicate the required pressure for the standpipe system which in many situations will far exceed 150 psi (10.3 bar).

~~A.4.6.2~~ ~~A.5.1.12.2~~

Continued operation enables the sprinklers to achieve full control of the fire, which, in some cases, can take 20 minutes or more.

~~A.4.4.4~~ ~~A.5.2.4~~

Adding 1/2 in. (13 mm) and 3/4 in. (19 mm) pipe nipples 6 in. (152 mm) in length with pipe caps installed on one end to the standard engine company inventory allows sprinkler systems a

Commented [SJ2]: FR 3 / PI 2, 10, 26

~~prompt return to service if no spare sprinklers are on site. In addition, a brightly painted and identified pipe nipple installed can assist fire inspectors and code enforcement officials with identifying areas of activation, while the absence of pipe nipples signifies the sprinkler system was restored to service.~~

~~A fire department and its members are not qualified to do any work on a sprinkler system and, therefore, should not be doing any type of work on the system. Taking any part of the system out of service to get another part back in service should only be done by a licensed professional.~~

A.5.2.4.1

Activated sprinklers potentially have evidentiary value and may need to be documented in place, collected, handled, and stored as evidence.

~~A.4.5.1—A.5.3.1~~

Reports on emergencies are essential to providing an accurate record of a department's activities, including sprinkler performance in structure alarms and fires.

Reports also serve as a basis for determining local, state, and national fire trends and for establishing the needs of a fire department. NFPA 901 should be used as the basis for classifying data on emergency incidents. The National Fire Incident Reporting System (NFIRS) of the Federal Emergency Management Agency should form the basis of an incident reporting system.

~~A.4.5.2(9)—A.5.3.2(9)~~

Some departments now use large diameter hose (LDH) lines to supply fire department connections.

~~A.5.1.1—A.5.4.1~~

These systems can be designed for automatic thermostatically operated or manual open-sprinkler operation. Some are specially designed sprinklers on pipes extending from a wet- or dry-pipe sprinkler system inside the building and placed to protect window openings.

~~A.5.4.1—A.5.5.1~~

The purpose of exterior sprinkler systems is to prevent the extension of fires to exposed properties.

~~A.6.1.3—A.6.1.2~~

The procedure for fire department pre-incident planning for properties protected by standpipe systems is in many ways similar to that for automatic sprinkler systems.

~~A.6.3.1—A.6.2.1~~

Many buildings could have sprinkler systems, standpipe systems, or a combination of these systems. Alternative sources of water meeting the requirements of NFPA 1142 can be used to supplement fire department water sources for supplying standpipe and sprinkler systems.

~~A.6.3.3~~—~~A.6.2.3~~

Standpipes can be combined with automatic sprinkler systems when the residual pressure from the municipal water mains provides adequate pressure and flow to the sprinkler systems. Fire departments will still need to charge the standpipe to the pressure required to give the desired working pressure at the standpipe outlets being used for hose line operations.

~~A.6.3.4~~—~~A.6.2.4~~

Fire department standpipe outlets are required by NFPA 14 to be located in the stair towers, adjacent to the horizontal exits, and near entrances to exit access corridors. In some cases, however, the standpipe might be located on the exterior of the building, frequently adjacent to outside stairs or a fire escape. Accepted practice in standpipe operations is to connect the fire department hose to an outlet located at the intermediate stair landing or one floor below the fire and to advance the line up the flight of stairs. The purpose of this practice is to prevent an intense fire on the fire floor from driving fire fighters away from the standpipe connection. Where additional lines are needed, connections can be made to lower outlets.

~~A.6.4.1~~—~~A.6.3.1~~

Automatic standpipes with fire pumps are very different from manual standpipes in many ways. NFPA 14 requires automatic standpipe systems to contain water at all times and be attached to a water supply capable of supplying the system demand at all times and requiring no action other than opening a hose valve to provide water at hose connections. This means automatic standpipe systems are designed to supply water, on-demand, without any assistance from the department pumpers.

~~A.7.1~~—~~A.7.1~~

An impairment is generally defined as a shutdown of a system or portion thereof. The two types of impairments are emergency and planned. An emergency impairment results from an unexpected occurrence. A planned impairment is scheduled for the purposes of repair or revisions.



Chapter 4 General

4.1* General.

Fire departments should be prepared to support fire protection systems provided with Fire Department Connections

Fire department administrations should use the record of effectiveness of automatic sprinkler systems and current data to promote these systems and should focus on actively supporting the operations of these systems.

4.1.1

Fire department personnel should be knowledgeable of and prepared to deal with the following three principal causes of unsatisfactory sprinkler performance:

- (1) A closed valve in the water supply line
- (2) The delivery of an inadequate water supply to the sprinkler system
- (3) Occupancy changes that render the installed system unsuitable

4.1.2

The fire department should correct these situations by implementing effective departmental pre-incident planning, inspections, and other appropriate actions. The use of sprinkler systems initially designed for a low-heat-release product or intended only to accommodate low storage when a change has been made to a high-heat commodity, a significantly increased storage height, or new storage configurations can result in unsuccessful sprinkler performance, so the fire department or authority having jurisdiction should take steps to correct such problems.

4.1.3

Whenever automatic sprinklers are installed within the jurisdiction, the fire department training program should include a course on the fundamentals of automatic sprinkler systems. The fire department should recognize the following:

- (1) When properly designed, installed, maintained, and supported by the fire department, a sprinkler system can apply water directly to the fire in a more effective manner than can the fire department using manual fire suppression methods.
- (2) Not all sprinkler systems are equally effective in their performance. Systems might not have been properly maintained or might not be effective for the current occupancy.
- (3) Changing conditions, including the following, might have reduced the required water supply calculated for sprinklers by the system designer:
 - (a) Installation of a backflow preventor
 - (b) Increased demand in area
 - (c) Partially closed valves
 - (d) Use of hose streams in larger volumes than anticipated

- (e) Deterioration of the water supply
 - (f) Degradation of the sprinkler pipe caused by corrosion
- (4) Changes in occupancies and commodity storage packaging and configuration methods might necessitate increased fire department support for the sprinkler system. Knowledge of sprinklered buildings within the response area will enable fire companies to be alert for the types of changes described in 4.1.3(3), which should be referred to the authority having jurisdiction so it can determine the need for sprinkler system modification.
- (5) Sprinkler systems are installed in single-family and multiple-family dwellings as well as other types of residential occupancies. Some of these systems might not have the traditional fire department connection and other traditional exterior building fittings or dedicated separate water supplies.

4.2* Inspection and Pre-Incident Planning.

4.2.1

Fire personnel should thoroughly understand the following about properties protected by automatic sprinklers and standpipes:

- (1) The construction, contents, and layout of the buildings, the nature of the occupancies protected by automatic sprinklers and/or standpipes, the extent of this protection, and the type of fire protection systems
- (2) The water supply to the fire protection systems, including the source and type of supply, the flow and pressure normally available, and the anticipated duration of the available supply
- (3) *The location of all sprinkler and/or standpipe control valves, the area controlled by each valve, and the consequence of shutting off each valve
- (4) The location of fire department connections to fire protection systems, the specific area each connection serves, and the water supply, hose, and pumper layout that will be used to feed the fire department connections (*See Figure 4.2.1.*)
- (5) The location of water supplies for handlines that can be used without jeopardizing the water supply to the operating sprinklers
- (6) An alternative means for supplying water to the system in case of damage to the fire department connection
- (7) The location of spare or replacement sprinklers
- (8) The location of water flow indicators and annunciator panels associated with the fire protection systems
- (9) Keyholder information for contact in case of emergency. Arrangements should be made with the property owners for entering the building as quickly as possible following

activation of sprinkler systems when the building is unattended in order to avoid using forcible entry equipment and the resulting damage.

- (10) The specific company assignment having the primary responsibility for charging the fire department connection
- (11) Fire department personnel should periodically verify that fire department connection inlet caps or plugs and inlet swivel(s) are operation and free from debris.
- (12) Standpipe hose threads should be checked for compatibility with fire department threads.

Figure 4.2.1 Fire Department Connection to Automatic Sprinkler and Standpipe Systems.

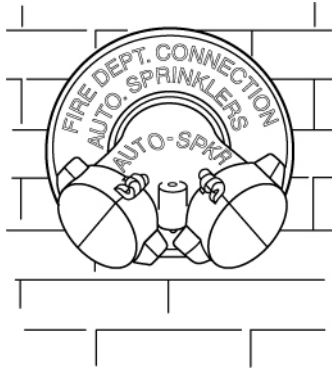

4.2.2 Periodic Inspection of Fire Department Connections

The company that is assigned primary responsibility for charging the sprinkler connection during pre-incident planning or annual inspections should

- (1) hook up to the fire department connection to verify hose thread compatibility
- (2) verify that fire department connection inlet caps or plugs and inlet swivel(s) are operational
- (3) verify that the fire department connection inlet is free from debris

4.2.3 Standpipe Systems

4.2.3.1

Where the fire department is required to supply hose outlets several hundred feet (meters) from the fire department connection, plans should be made in advance to provide the required pressure and fire flow based on the size of hose, the length of pipe, the maximum height of standpipe outlets, and the number of streams to be supplied.

4.2.3.2

Pre-incident planning should include identification of pressure-regulation devices installed within the system. For those standpipe systems with devices that regulate the pressure available to the hose lines attached to the system, fire personnel should be aware of the devices and their placement on standpipe systems and know how to adjust them so that they

work properly with the hose lines and nozzles that can be attached to them. Pressure-regulation device settings should be compatible with the hose and nozzles used by the local fire department.

4.2.3.3*

Standpipe hose outlets should be checked annually by opening and closing the valves.

4.2.3.4* Pressure-Regulating Devices Used in Automatic Standpipe Systems.

Fire department personnel should be thoroughly familiar with the design and function of the various types of pressure-regulating devices used in automatic standpipe systems in their jurisdictions.

4.3 Water Supply for Fire Fighting.

4.3.1*

A sketch should be prepared showing the location of the control valves, the fire department supply connections, and the hydrants to be used for pumping into the system. Where exposure fire is a problem, an assumption should be made that a major fire could happen that will also require a number of hose streams for manual firefighting. An assumption should also be made that standard automatic sprinkler systems might be in the fire area that must be supplied with lines from pumpers as their water supplies.

4.3.2

When possible, fire departments should avoid drafting from open water sources into sprinkler systems and standpipe systems where such systems are connected to potable water supplies unless appropriate backflow protection equipment is installed.

4.3.3.*

Fire personnel should be familiar with the variety of supply sources for water used in firefighting, including standpipe systems with water supplied by public or private water mains, as well as fire pumps, gravity tanks, pressure tanks, fire department connections, or combinations of these, in order to provide water at adequate pressure and quantity at the outlets.

4.3.4 Fire personnel should determine the needed pressure and quantity of water at the highest and lowest hose outlets, and they should develop procedures to provide appropriate amounts of water for firefighting when using the system.

4.3.5

Alternative means of supplying water to the fire area should be identified in case the standpipe system is unusable or needs to be supplemented at the time of a fire.

4.3.6 Automatic Standpipe Water Supply Considerations.

4.3.6.1*

Fire departments should plan water supply operations to support the automatic standpipe systems in their jurisdictions.

4.3.6.2*

The fire department's initial water supply action should be to support the automatic standpipe as a secondary water supply.

4.3.6.3*

Fire department pumpers should pump the system demand pressure and flow into the fire department connection when taking over any automatic standpipe or standpipe zone.



Chapter 5 Properties Protected by Sprinkler Systems

5.1 Fireground Operations in Sprinklered Properties.

5.1.1

Each fire department responding to properties protected by automatic sprinkler systems should implement standard operating procedures for handling fires in sprinklered buildings. The incident commander should ensure that these procedures are carried out as promptly and efficiently as possible. (See Annex B.)

5.1.2

Fire fighters operating in properties protected by automatic sprinkler systems should base operations on a thorough knowledge of the property gained from prior inspection and pre-incident planning.

5.1.3

A sprinkler system should not be shut down to improve visibility.

5.1.4*

When arriving at a property protected by an automatic sprinkler system, fire companies should take prompt action to supply the system. [See Figure 5.1.4(a) and Figure 5.1.4(b).] A minimum of one sprinkler supply line should be connected to the fire department connection and should be supplemented according to fire conditions. The supply line should be pumped and the line charged to a pressure of 150 psi (10.3 bar) unless the system is posted for a different pressure. Additional hose lines should be stretched to the fire area as directed by the incident commander in charge. [See Figure 5.1.4(c).]

Figure 5.1.4(a) Public Water Supply to the Sprinkler System.

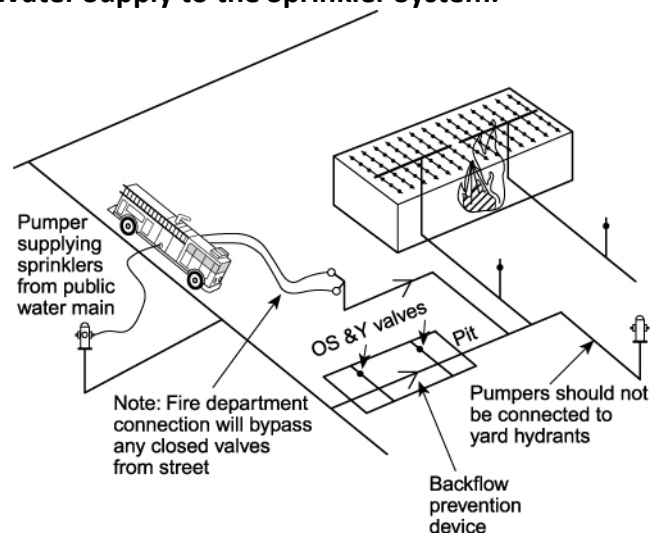

Figure 5.1.4(b) Water Supply to the Fire Department Connection.

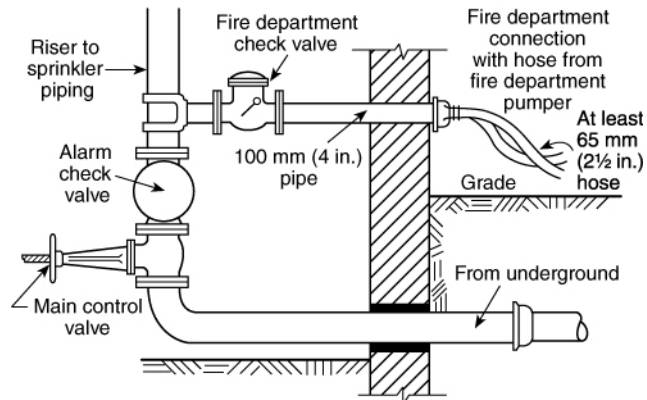
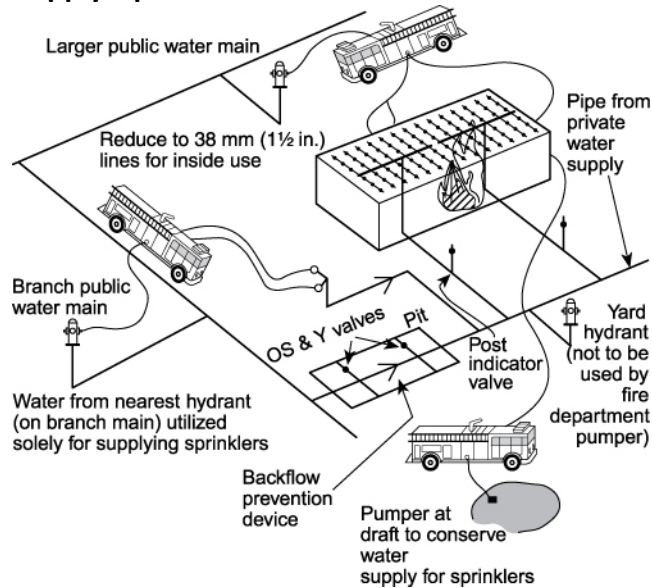

Figure 5.1.4(c) Pumper Supply Options That Should Be Considered.



5.1.5

Where hose streams will be used, water should be taken from sources that do not reduce the sprinklered protection. Pumpers should be supplied by one of the following methods:

- (1) Connecting pumpers to large mains from which flow tests have indicated adequate flows to supply both sprinklers and the required hose streams
- (2) Connecting pumpers to water mains not needed for sprinkler supply
- (3) Drafting pumpers from static sources

5.1.6

Immediately after all water supply connections have been completed and the fire department connection has been charged, the incident commander should verify that water is flowing into the sprinkler system. If water is not flowing, the incident commander should take action to verify that all accessible control valves are open. If a valve is found to be closed, the incident commander should be notified promptly and the valve should be opened fully unless it is tagged "Closed for Repairs." Valves found closed should be reported to the fire investigator

after the incident. If the system is supplied or augmented by a fire pump, a fire fighter should also be assigned to verify that the pump is in operation.

5.1.7

When possible, fire departments should avoid drafting from open water sources into sprinkler systems and standpipe systems where such systems are connected to potable water supplies unless appropriate backflow protection equipment is installed.

5.1.8

Personnel performing ladder company functions should provide ventilation as needed to avoid delay in advancing hose lines to complete extinguishment. *(See Section 5.1.12 for other considerations regarding ventilation procedures.)*

5.1.9

Salvage covers should be used to protect those items or areas likely to be affected by operating sprinklers, hose lines, or both. Special attention should be given to those areas on floor levels below the area of sprinkler operation.

5.1.10

Fire personnel should be aware that not all residential sprinkler piping is tested to the same level as commercial sprinkler piping. Therefore, a residential sprinkler system should not be pressurized to more than water main pressure if this system has a fire department connection.

5.1.11

Appropriate plans for water removal should be undertaken.

5.1.12 Ventilation in Storage Occupancies.

5.1.12.1

Fire department personnel should study occupancies with a wide variety of configurations and a wide range of storage commodities to determine whether there is a need for special procedures, particularly where storage heights are in excess of 12 ft (3.66 m). This study should be done because, in some cases, routine ventilation procedures in the early stages of a fire can hinder effective sprinkler operation. The fire department should discuss its pre-incident plan for these types of occupancies with the occupant, sprinkler system designer, and insurance carrier to determine whether a modification in procedures is appropriate.

5.1.12.2*

Where search and rescue operations have been completed prior to the fire department's performance of ventilation work, the incident commander should allow the automatic sprinklers to continue to operate without further ventilation.

5.2 Post-Fire Operations.

5.2.1

Automatic sprinklers should not be shut off until the fire has been extinguished. If there is a sectional or floor fire control valve, this valve should be closed in lieu of the main valve. A fire fighter with a means of communication should be assigned to remain at the valve until overhaul is completed. Orders should also be given to the pump operator to shut down the lines connected to the fire department connection, because these lines can bypass the main sprinkler valve and, in the absence of a floor valve, water will flow until the pump discharge gates are closed. Where a combined sprinkler–standpipe system is installed, the hose lines

should be charged and maintained charged until fire overhaul is completed. Where only a few sprinklers are operating, sprinkler tongs, tapered wooden wedges, or dowels should be used to immediately stop the flow from the opened sprinklers without shutting off the entire system.

(See Figure 5.2.1.)

Figure 5.2.1 Sprinkler with Sprinkler Wedge Installed.

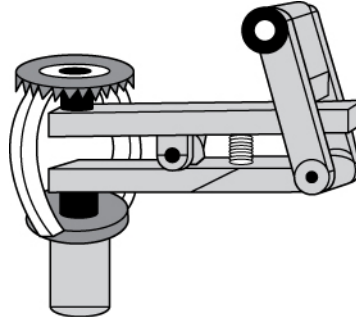

5.2.2

Routine overhaul should be provided and a cause and origin investigation should be initiated.

5.2.3

When the fire is extinguished and overhaul is completed, the lines from the pumper to the sprinkler system fire department connection should be ordered disconnected.

5.2.4*

Where appropriate, the fire department should assist in restoring the sprinkler system. Because actions to restore a sprinkler system can present potential consequences for improper or negligent actions, fire department personnel should not replace fire sprinklers. Sprinklers that were exposed to high heat conditions during a fire should be examined by a qualified sprinkler installer and replaced as needed.

5.2.4.1

Sprinklers that have operated during a fire emergency should not be removed until approved by fire investigators.

A.5.2.4.1 Activated sprinklers potentially have evidentiary value and may need to be documented in place, collected, handled, and stored as evidence.

5.2.5

Code enforcement and fire prevention authorities should be notified of any event that involves activation of an automatic sprinkler system.

5.2.5.1

If the sprinkler system cannot be restored to operating condition by the time the fire department leaves the premises, the code enforcement and/or fire prevention authorities and the building owner/representative should be promptly notified of the structure's noncompliant status. Depending on post-fire conditions, the fire department or code enforcement authority should consider requiring a fire watch.

5.3 Reports.

5.3.1*

The officer in charge should include data regarding the operation of the sprinkler system in the incident report.

5.3.2

Past incident analysis of fire department operations and the performance of the automatic sprinkler system should be reported to improve future operations at sprinklered properties. The following information should be gathered to use in the analysis process:

- (1) Location of operating sprinklers
- (2) Number of sprinklers operating
- (3) Result of sprinkler operation
- (4) Reason for any unsatisfactory operation
- (5) Employee assigned to check control valve
- (6) Whether the fire department connected to the sprinkler system and, if not, the reason
- (7) Company and engine number that connected to the sprinkler system
- (8) Number of hose lines used
- (9) *Size of hose lines used
- (10) Whether water was pumped into the system; if so, for how long and at what pressure; and any issues with the backflow device or pressure-reducing devices
- (11) Whether the valve was closed after the fire, and which employee ordered that the valve be closed
- (12) Number of sprinklers replaced by the fire department
- (13) Type of sprinklers installed
- (14) Whether sprinkler protection was fully restored and by whom
- (15) Actions taken to restore service
- (16) Whether the private water supply to sprinklers operated satisfactorily
- (17) Whether the fire prevention bureau was notified
- (18) Whether the representative of management was notified as well as the names of the employee making notification and of those notified

5.4 Exterior Sprinkler Systems.

5.4.1*

Fire department personnel should be aware that many buildings or properties that have a severe exposure problem might be equipped with exterior sprinkler systems designed to provide a water curtain capable of shielding the property from fires in other buildings or in storage areas.

5.4.2

Fire department training and operational protocols should be in place so that, when used properly, sprinklers for exterior protection (specially designed for a water curtain effect) and sprinkler systems will prevent an exposure fire from entering the building.

5.5 Fireground Operations Involving Exterior Sprinklers.

5.5.1*

The incident commander in charge should ensure that exterior systems are used to fulfill their intended purpose and should be aware of the existence of the system and the means of water supply.

5.5.2

The incident commander should determine as quickly as possible whether exterior sprinklers are operating. If the system is manually operated, a fire department member with a portable radio should immediately be sent to open the valve in case the exterior sprinklers are needed later. In some cases, several valves control different exposed parts of a protected building, so the correct valve must be opened. Care should be taken to conserve the water supply and minimize potential water damage by shutting off the exterior sprinklers when they are no longer required.

5.5.3

Where a fire department connection is provided, an engine company should pump into the connection.

5.5.4

The incident commander in charge should be responsible for the following:

- (1) Ordering fire personnel into the exposed buildings to ascertain that all windows are closed and fire has not extended into the buildings concerned
- (2) Setting up fire department lines in the exposed buildings if the exposure is severe; standpipe facilities can be used if available.
- (3) Sending fire personnel to the roof to make certain that no part of the roof structure has ignited
- (4) Ordering salvage operations in exposed buildings
- (5) Ordering exterior sprinklers to be shut off and drained when no longer needed
- (6) Ordering the system to be restored (*see 4.4.4*)



Chapter 6 Properties Protected by Standpipe Systems

6.1 Inspection and Pre-Incident Planning.

6.1.1

Personnel responsible for inspection and pre-incident planning should be aware that many properties have standpipe systems serving fire hose outlets in various parts of one or more buildings and that standpipe systems can be used by the fire personnel to place streams in service quickly in areas that cannot be reached conveniently with hose lines that are directly connected to pumpers or hydrants outside of buildings.

6.1.2*

Fire personnel should determine the source and reliability of the water supply and follow the piping, while noting the location of control valves.

6.2 Fireground Operations Involving Properties Protected by Manual Dry or Manual Wet Standpipe Systems.

6.2.1*

Fire department personnel should carefully plan operations in properties protected by standpipe systems designed to supply fire department hose streams. These procedures should be similar to operations in buildings protected by automatic sprinklers.

6.2.2

Standpipes should be utilized when fires occur on floors above the reach of ground or aerial ladders and when valuable time will be lost in stretching lines up stairways. Careful pre-incident and on-scene fireground planning should be performed to ensure successful operations.

6.2.3*

Where standpipe systems provide fire department connections, lines from a pumper supplied by a water main should be connected and charged to the pressure required to give the desired working pressure on the standpipe outlets being used. Where several independent standpipes are available for fire department use in the fire area, each standpipe should be charged. (See *Figure 6.2.3.*)

Figure 6.2.3 Standpipe Connection.



6.2.4* Fire Department Standpipe Connections and Pump Discharge Pressures for Manual Dry or Manual Wet Standpipes.

6.2.4.1

When pumping to a fire department standpipe connection, the pump operator should consider the following factors in calculating pump discharge pressure:

- (1) Friction loss in the hose line between the pump and the standpipe connection
- (2) Friction loss in the standpipe system
- (3) Pressure loss due to elevation of the nozzle(s)
- (4) Number, length, and size of attack lines operating from the standpipe
- (5) Pressure desired at the nozzle(s)

6.2.4.2

Pump discharge pressure in excess of 200 psi (13.8 bar) should not be used unless the standpipe system has been designed to withstand higher pressures. Fire suppression personnel should be familiar with options and acceptable practices available to them in response to varying configurations and locations of standpipe outlets.

6.2.5

Hose or “house lines” attached to standpipe outlets should not be used except in the case of extreme emergency. Fire personnel should provide hose and nozzles of appropriate size and length along with proper accessory equipment for the anticipated fire conditions.

6.2.6

Limitations of communication devices, as well as the essential ability to maintain effective portable radio communications between the incident command post and officers on the upper floors, should be identified and resolved during pre-incident planning.

6.2.7

Where private water supplies serve the standpipe system, fire personnel should make certain that supply valves are open and private fire pumps, if any, are operating.

6.2.8

Before proceeding upstairs, fire personnel should ensure that all hose outlet valves on lower floors are closed.

6.2.9

Fire departments should operate hose lines from standpipe hose valves on the intermediate stair landing or floor below the fire floor in multi-story buildings and in areas remote from the emergency in other standpipe-equipped structures. Where possible to do so, fire fighters should connect and deploy hose lines from standpipe hose valves outside any immediately dangerous to life and health (IDLH) environment to ensure the safety and operational effectiveness of all fire department personnel.

6.2.10

Fire departments operating in standpipe-equipped buildings should utilize appropriately sized hose lines based on their required pre-incident planning for those structures. Fire fighters should base this decision upon necessary fire flows for the hazard of the building, conditions at the time of the incident, and operational capabilities of the system. Fire departments should be cognizant of the possibility of low operating pressures that can warrant the choosing of larger hose lines of 2½ in. (63.5 mm) and nozzles that require lower operating pressures for initial

fire department operations from a standpipe system. The authority having jurisdiction should have the ultimate decision in regard to the fire department hose line selection for use when operating from standpipes.

6.3 Fireground Operations Involving Properties Protected by Automatic Standpipe Systems with Fire Pumps.

6.3.1*

Fire department personnel should carefully plan operations in properties protected by automatic standpipe systems that are designed to supply fire department hose streams and combined sprinkler systems. These procedures should be specific to automatic standpipes with fire pumps.

6.3.2

Fire suppression operations can be limited to the pressure and flow design of the standpipe. Fire departments should limit interior fire suppression operations to be within the pressure and flow parameters specific to each automatic standpipe system.



First Revision No. 23-NFPA 13E-2018 [Detail]

5.2.4.1*

Sprinklers that have operated during a fire emergency should not be removed until approved by fire investigators.

A.5.2.4.1

Activated sprinklers potentially have evidentiary value and might need to be documented in place, collected, handled, and stored as evidence.

Submitter Information Verification

Submitter Full Name: Jeremy Souza

Organization: National Fire Protection Assoc

Street Address:

City:

State:

Zip:

Submittal Date: Mon May 07 17:26:45 EDT 2018

Committee Statement

Committee Statement: The Committee agrees that that activated sprinkler heads should be retained for evidence.

Response Message:

Public Input No. 27-NFPA 13E-2018 [New Section after 4.4.4]



First Revision No. 24-NFPA 13E-2018 [Detail]

4.1* General.

Fire departments should be prepared to support fire protection systems provided with fire department connections. Fire department administrations should use the record of effectiveness of automatic sprinkler systems and current data to promote these systems and should focus on actively supporting the operations of these systems

Submitter Information Verification

Submitter Full Name: Sonia Barbosa
Organization: [Not Specified]
Street Address:
City:
State:
Zip:
Submittal Date: Thu May 10 11:40:16 EDT 2018

Committee Statement

Committee Statement: The committee has added this opening statement to better emphasize the overall objective of this Guide.
Response Message:



First Revision No. 6-NFPA 13E-2018 [Section No. 2.2]

2.2 NFPA Publications.

National Fire Protection Association, 1 Batterymarch Park, Quincy, MA 02169-7471.

NFPA 25, *Standard for the Inspection, Testing, and Maintenance of Water-Based Fire Protection Systems*, 2014 2020 edition.

NFPA 241, *Standard for Safeguarding Construction, Alteration, and Demolition Operations*, 2013 2019 edition.

Submitter Information Verification

Submitter Full Name: Robert Fash

Organization: National Fire Protection Assoc

Street Address:

City:

State:

Zip:

Submittal Date: Tue Mar 20 22:48:28 EDT 2018

Committee Statement

Committee Statement: NFPA editions updated

Response Message:

[Public Input No. 20-NFPA 13E-2018 \[Chapter 2\]](#)



First Revision No. 7-NFPA 13E-2018 [Section No. 2.4]

2.4 References for Extracts in Recommendations Sections.

NFPA 13, *Standard for the Installation of Sprinkler Systems*, 2019 edition.

NFPA 14, *Standard for the Installation of Standpipe and Hose Systems*, 2013 2019 edition.

NFPA 24, *Standard for the Installation of Private Fire Service Mains and Their Appurtenances*, 2013 2019 edition.

Submitter Information Verification

Submitter Full Name: Robert Fash

Organization: National Fire Protection Assoc

Street Address:

City:

State:

Zip:

Submittal Date: Tue Mar 20 22:53:50 EDT 2018

Committee Statement

Committee Statement: NFPA 13 added, NFPA editions updated

Response Message:



First Revision No. 16-NFPA 13E-2018 [Section No. 3.3]

3.3 General Definitions.

3.3.1 Fire Department Connection.

A connection through which the fire department can pump supplemental water into the sprinkler system, standpipe, or other water-based fire protection systems, thereby supplementing existing water supplies. [24, 2019]

3.3.2 Hydrant.

An exterior valved connection to a water supply system that provides hose connections.

3.3.2.1* Private Fire Hydrant.

A valved connection on a water supply system having one or more outlets that is used to supply hose and fire department pumpers with water on private property.

A.3.3.2.1 Private Fire Hydrant.

Where connected to a public water system, private hydrants are supplied by a private service main that begins at the point designated by the AHJ, usually at a manually operated valve near the property line.

3.3.2.2 Public Hydrant.

A valved connection on a water supply system having one or more outlets that is used to supply hose and fire department pumpers with water.

3.3.2.3 Yard Hydrant.

A hydrant that is not designed to supply a fire department pumper.

3.3.3 Pressure-Regulating Device.

A device designed for the purpose of reducing, regulating, controlling, or restricting water pressure.

[24,2013 2019]

3.3.4* Sprinkler System.

A system, commonly activated by heat from a fire and discharges water over the fire area, that consists of an integrated network of piping designed in accordance with fire protection engineering standards that includes a water supply source, a water control valve, a waterflow alarm, and a drain. The portion of the sprinkler system above ground is a network of specifically sized or hydraulically designed piping installed in a building, structure, or area, generally overhead, and to which sprinklers are attached in a systematic pattern. [13, 2019]

A.3.3.4 Sprinkler System.

As applied to the definition of a sprinkler system, each system riser serving a portion of a single floor of a facility or where individual floor control valves are used in a multistory building should be considered a separate sprinkler system. Multiple sprinkler systems can be supplied by a common supply main. [13, 2019]

3.3.5 Standpipe System.

An arrangement of piping, valves, hose connections, and ~~allied~~ associated equipment installed in a building or structure, with the hose connections located in such a manner that water can be discharged in streams or spray patterns through attached hose and nozzles, for the purpose of extinguishing a fire, thereby protecting a building or structure and its contents in addition to protecting the occupants.

[14,2013 2019]

3.3.5.1 Automatic Dry Standpipe System.

A standpipe system permanently attached to a water supply capable of supplying the system demand at all times, containing air or nitrogen under pressure, the release of which (as from opening a hose valve) opens a dry pipe valve to allow water to flow into the piping system and out of the opened hose valve.

[14, 2019]

3.3.5.2 Automatic Wet Standpipe System.

A standpipe system containing water at all times that is attached to a water supply capable of supplying the system demand at all times and that requires no action other than opening a hose valve to provide water at hose connections. [14, 2019]

3.3.5.3 Combined System.

A standpipe system that supplies both hose connections and automatic sprinklers. [14, 2019]

3.3.5.4 Manual Dry Standpipe System.

A standpipe system with no permanently attached water supply that relies exclusively on the fire department connection to supply the system demand. [14, 2019]

3.3.5.5 Manual Wet Standpipe System.

A standpipe system containing water at all times that relies exclusively on the fire department connection to supply the system demand. [14, 2019]

3.3.5.6 Semiautomatic Dry Standpipe System.

A standpipe system permanently attached to a water supply that is capable of supplying the system demand at all times arranged through the use of a device such as a deluge valve and that requires activation of a remote control device to provide water at hose connections. [14, 2019]

3.3.5.7 Wet Standpipe System.

A standpipe system having piping containing water at all times. [14, 2019]

Supplemental Information

<u>File Name</u>	<u>Description</u>	<u>Approved</u>
13E_Chapter_3_w_new_definitions.docx	Clean version/includes annex--for staff use	

Submitter Information Verification

Submitter Full Name: Robert Fash
Organization: National Fire Protection Assoc
Street Address:
City:
State:
Zip:
Submittal Date: Tue Apr 03 13:36:50 EDT 2018

Committee Statement

Committee Statement: Definitions added and updated as necessary for the standard.

Response Message:



First Revision No. 19-NFPA 13E-2018 [Section No. 4.2.1]



4.2.1

Fire personnel should thoroughly understand the following about properties protected by automatic sprinklers and standpipe systems :

- (1) The construction, contents, and layout of the buildings, the nature of the occupancies protected by automatic sprinklers or standpipes , the extent of this protection, and the type of sprinkler fire protection systems.
- (2) The water supply to the sprinklers fire protection systems , including the source and type of supply, the flow and pressure normally available, and the anticipated duration of the available supply.
- (3)* The location of all sprinkler or standpipe control valves, the area controlled by each valve, and the consequence of shutting off each valve.
- (4) The location of fire department connections to sprinkler fire protection systems, the specific area each connection serves, and the water supply, hose, and pumper layout that will be used to feed the sprinkler fire department connections. (See Figure 4.2.1.)
- (5) The location of water supplies for handlines that can be used without jeopardizing the water supply to the operating sprinklers.
- (6) An alternative means for supplying water to the system in case of damage to the fire department connection.
- (7) The location of spare or replacement sprinklers.
- (8) The location of water flow indicators and annunciator panels associated with the fire protection systems.
- (9) Keyholder information for contact in case of emergency. Arrangements should be made with the property owners for entering the building as quickly as possible following activation of sprinkler systems when the building is unattended in order to avoid using forcible entry equipment and the resulting damage.
- (10) The company assigned responsibility for charging the fire department connection.
- (11) Fire department personnel should periodically verify that fire department connection inlet caps or plugs and inlet swivel(s) are operational and free from debris.
- (12) Standpipe hose threads should be checked for compatibility with fire department threads.

Figure 4.2.1 Fire Department Connection to Automatic Sprinkler Systems.

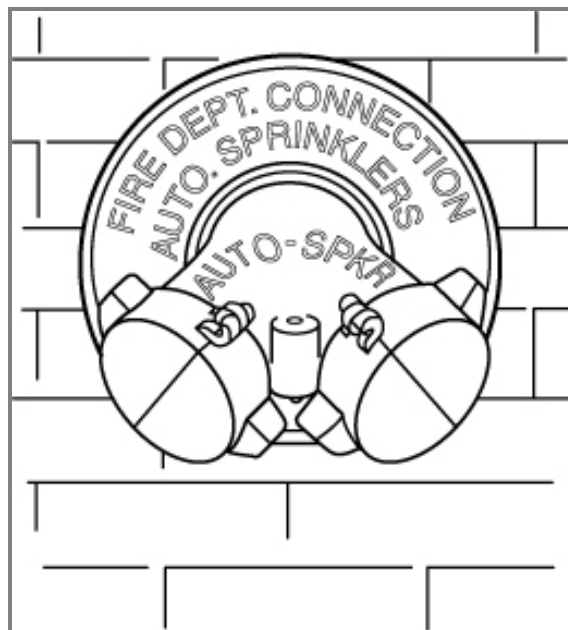

Submitter Full Name: Jeremy Souza

Organization: National Fire Protection Assoc

Committee Statement

Street Address:

City:

Committee

State:

Response

Message

Date: Wed May 02 11:01:30 EDT 2018

List items 10, 11, and 12 added to consolidate with similar lists in Chapters 5 and 6. Instances of "sprinkler" in the section expanded to include standpipes as well.



First Revision No. 20-NFPA 13E-2018 [Section No. 4.2.2]

4.2.2 Periodic Inspection of Fire Department Connections.

The company that is assigned primary responsibility for charging the sprinkler connection during pre-incident planning or annual inspections should do the following:

- (1) Hook Hook up to the fire department connection to verify hose thread compatibility.
- (2) Verify that fire department connection inlet caps of plugs and inlet swivel(s) are operational.
- (3) Verify that the fire department connection inlet is free from debris.

Submitter Information Verification

Submitter Full Name: Jeremy Souza
Organization: National Fire Protection Assoc
Street Address:
City:
State:
Zip:
Submittal Date: Wed May 02 13:46:14 EDT 2018

Committee Statement

Committee Statement: Items were added to this section to better describe the inspection process of a fire department connection.
Response Message:



First Revision No. 2-NFPA 13E-2018 [Section No. 4.3.9]

5.1.9*

Salvage covers should be used to protect those items or areas likely to be affected by operating sprinklers, hose lines, or both. Special attention should be given to those areas on floor levels below the area of sprinkler operation.

A.5.1.9

Preplanning should include the collection of information needed to prioritize salvage of particularly valuable or sensitive items. Some occupancies, such as museums and libraries, will have formal salvage plans in place that should be consulted. For example, NFPA 909 provides a structured approach for this purpose.

Submitter Information Verification

Submitter Full Name: Robert Fash
Organization: National Fire Protection Assoc
Street Address:
City:
State:
Zip:
Submittal Date: Tue Mar 20 17:24:58 EDT 2018

Committee Statement

Committee Statement: The committee added annex language to recognize salvage pre-planning for valuable or sensitive items associated with museums, libraries and similar occupancies.

Response Message:

Public Input No. 24-NFPA 13E-2018 [Section No. 4.3.9]



First Revision No. 3-NFPA 13E-2018 [Section No. 4.4.4]

5.2.4*

Where appropriate, the fire department should assist in restoring the sprinkler system. Because actions to restore a sprinkler system can present potential consequences for improper or negligent actions, each fire department should review its policy on this matter. Where fire departments are tasked with restoring sprinkler systems post-fire or after accidental sprinkler activations, departments should consider using $\frac{1}{2}$ in. (13 mm) or $\frac{3}{4}$ in. (19 mm) pipe nipples with caps if spare sprinklers are not available. This provides complete sprinkler protection, which facilitates reoccupation of areas not affected by fire, smoke, or water damage. department personnel should not replace fire sprinklers. Sprinklers that were exposed to high heat conditions during a fire should be examined by a qualified sprinkler installer and replaced as needed.

A.5.2.4

Adding $\frac{1}{2}$ in. (13 mm) and $\frac{3}{4}$ in. (19 mm) pipe nipples 6 in. (152 mm) in length with pipe caps installed on one end to the standard engine company inventory allows sprinkler systems a prompt return to service if no spare sprinklers are on site. In addition, a brightly painted and identified pipe nipple installed can assist fire inspectors and code enforcement officials with identifying areas of activation, while the absence of pipe nipples signifies the sprinkler system was restored to service. A fire department and its members are not qualified to do any work on a sprinkler system and, therefore, should not be doing any type of work on the system. Taking any part of the system out of service to get another part back in service should only be done by a licensed professional.

[Detail FR-23](#)

5.2.4.1*

Sprinklers that have operated during a fire emergency should not be removed until approved by fire investigators.

Supplemental Information

<u>File Name</u>	<u>Description Approved</u>
13E_FR-3_Annex_changes_to_be_included_in_ballot.docx	For staff use

Submitter Information Verification

Submitter Full Name: Robert Fash
Organization: National Fire Protection Assoc
Street Address:
City:
State:
Zip:
Submission Date: Tue Mar 20 17:31:50 EDT 2018

Committee Statement

Committee Statement: The committee revised this section to give guidance that a qualified person should place a fire sprinkler system back into service.

Response Message:

[Public Input No. 10-NFPA 13E-2017 \[Section No. 4.4.4\]](#)

[Public Input No. 2-NFPA 13E-2016 \[Section No. 4.4.4\]](#)

[Public Input No. 26-NFPA 13E-2018 \[Section No. 4.4.4\]](#)



First Revision No. 5-NFPA 13E-2018 [Section No. 4.4.5.1]

5.2.5.1

If the sprinkler system cannot be restored to operating condition by the time the fire department leaves the premises, the code enforcement and/or fire prevention authorities and the building owner/representative should be promptly notified of the structure's noncompliant status. ~~Depending on post-fire conditions, the fire department or code enforcement authority should consider requiring a fire watch. This condition~~ should be regarded as an impairment. *(See Chapter 7 Impairments.)*

Submitter Information Verification

Submitter Full Name: Robert Fash
Organization: National Fire Protection Assoc
Street Address:
City:
State:
Zip:
Submission Date: Tue Mar 20 17:48:41 EDT 2018

Committee Statement

Committee Statement: This modification removes redundancy and improves consistency within the document.

Response Message:

[Public Input No. 25-NFPA 13E-2018 \[Section No. 4.4.5.1\]](#)



First Revision No. 10-NFPA 13E-2018 [Section No. 6.2.2]

4.3.4

Fire personnel should determine the needed pressure and quantity of water at the highest and lowest outlets, and they should develop procedures to provide appropriate amounts of water for fire fighting when using the system.

Submitter Information Verification

Submitter Full Name: Robert Fash

Organization: National Fire Protection Assoc

Street Address:

City:

State:

Zip:

Submittal Date: Tue Mar 20 23:11:53 EDT 2018

Committee Statement

Committee Statement: Committee recognizes the need to account for hose connections below grade that require adjustment in water pressure by the fire department pumper.

Response

Message:



First Revision No. 21-NFPA 13E-2018 [Section No. 6.2.3]

4.3.5

Alternative means of supplying water to the fire area should be identified in case the standpipe system is unusable or needs to be supplemented at the time of a fire.

Submitter Information Verification

Submitter Full Name: Jeremy Souza

Organization: National Fire Protection Assoc

Street Address:

City:

State:

Zip:

Submittal Date: Wed May 02 14:34:18 EDT 2018

Committee Statement

Committee Statement: Text added to clarify the type of system the section refers to.

Response Message:



First Revision No. 8-NFPA 13E-2018 [Section No. 6.3.4.1]

6.2.4.1

When pumping to a fire department standpipe connection, the pump operator should consider the following factors in calculating pump discharge pressure:

- (1) Friction loss in the hose line between the pump and the standpipe connection
- (2) Friction loss in the standpipe system
- (3) Pressure loss due to elevation of the nozzle(s)
- (4) Number, length, and size of attack lines operating from the standpipe
- (5) Pressure desired at the nozzle(s)
- (6) Signage on the fire department connection indicating pressure required at the inlet

Submitter Information Verification

Submitter Full Name: Robert Fash

Organization: National Fire Protection Assoc

Street Address:

City:

State:

Zip:

Submittal Date: Tue Mar 20 23:07:16 EDT 2018

Committee Statement

Committee Statement: The committee added the requirement for signage to be consistent with NFPA 14.

Response Message:

Public Input No. 3-NFPA 13E-2016 [Section No. 6.3.4.1]



First Revision No. 9-NFPA 13E-2018 [Section No. 6.3.4.2]

6.2.4.2

Pump discharge pressure in excess of 200 psi (13.8 bar) should not be used unless the standpipe system has been designed to withstand higher pressures as indicated on the sign at the fire department connection . Fire suppression personnel should be familiar with options and acceptable practices available to them in response to varying configurations and locations of standpipe outlets.

Submitter Information Verification

Submitter Full Name: Robert Fash
Organization: National Fire Protection Assoc
Street Address:
City:
State:
Zip:
Submittal Date: Tue Mar 20 23:09:30 EDT 2018

Committee Statement

Committee Statement: NFPA 14 requires that a sign be provided at the fire department connection. (Section 6.4.5.2.2). There are many buildings (especially high rise) where the required pressures far exceed 200 PSI.

Response Message:

[Public Input No. 4-NFPA 13E-2016 \[Section No. 6.3.4.2\]](#)



First Revision No. 11-NFPA 13E-2018 [Section No. 7.1 [Excluding any Sub-Sections]]

When a sprinkler system or standpipe system is found to be impaired, fire department procedures should be followed as covered in Chapter 41 15 of NFPA 25. Each building owner should appoint an impairment coordinator for the purpose of authorizing planned impairments and dealing with emergency impairments.

Submitter Information Verification

Submitter Full Name: Robert Fash

Organization: National Fire Protection Assoc

Street Address:

City:

State:

Zip:

Submittal Date: Tue Mar 20 23:27:46 EDT 2018

Committee Statement

Committee Statement: The modification updates the reference to NFPA 25 (2017).

Response Message:

[Public Input No. 17-NFPA 13E-2018 \[Section No. 7.1 \[Excluding any Sub-Sections\]\]](#)



First Revision No. 12-NFPA 13E-2018 [Section No. 7.1.1]

7.1.1

When an impairment occurs, the following procedure should be performed by the impairment coordinator:

- (1) Determine the extent and expected duration of the impairment
- (2) Determine the increased risk in the areas of the building affected
- (3) Submit recommendations to the owner or manager of the building for dealing with the risk
- (4) Where a fire protection system is out of service for more than 10 hours in a 24-hour period, arrange for one of the following:
 - (a) Evacuation of the building or portion of the building affected by the system out of service
 - (b)* Establishment of an approved fire watch

A.7.1.1(4)(b)

A fire watch should consist of trained personnel who continuously patrol the affected area. Ready access to fire extinguishers and the ability to promptly notify the fire department are important items to consider. During the patrol of the area, the person should not only be looking for fire, but making sure that the other fire protection features of the building such as egress routes and alarm systems are available and functioning properly.

[**25:** A.15.5.2(4)(b)]

- (c)* Establishment of a temporary water supply
 - (d)* Establishment and implementation of an approved program to eliminate potential ignition sources and limit the amount of fuel available to the fire
 - (5) Notify the fire department and the dispatch center for emergency services
 - (6) Notify the insurance carrier, the alarm company, the building property owner or manager designated representative , and other involved authorities having jurisdiction
 - (7) Notify the supervisors in the area being affected
 - (8) Install an impairment tag on the affected control valve and fire department connection
 - (9) Assemble the necessary tools and materials to make the repair as quickly as possible
- ~~Prohibit all welding, cutting, and other forms of hot work~~
- ~~Consider establishing a fire watch~~

Supplemental Information

<u>File Name</u>	<u>Description Approved</u>
13E-7.1.1.1.docx	For staff use

Submitter Information Verification

Submitter Full Name: Robert Fash
Organization: National Fire Protection Assoc
Street Address:
City:
State:

Zip:

Submittal Date: Tue Mar 20 23:32:37 EDT 2018

Committee Statement

Committee Statement: This modification aligns the text with NFPA 25 (2017) (See attached document for clarity)

Response Message:

[Public Input No. 18-NFPA 13E-2018 \[Section No. 7.1.1\]](#)



First Revision No. 1-NFPA 13E-2018 [Section No. 9.1]

9.1 Site Visits.

Fire department personnel should provide continual preplan visits to high-rise buildings under construction to evaluate special needs in accordance with the provisions of Chapter 5 7 of NFPA 241.

Submitter Information Verification

Submitter Full Name: Robert Fash

Organization: National Fire Protection Assoc

Street Address:

City:

State:

Zip:

Submittal Date: Tue Mar 20 14:54:42 EDT 2018

Committee Statement

Committee Statement: Committee changed the NFPA 241 (2013) Chapter 7 Fire Protection

Response Message:

Public Input No. 19-NFPA 13E-2018 [Section No. 9.1]



First Revision No. 13-NFPA 13E-2018 [Section No. A.4.3.4]

A.5.1.4

Fire department pumpers should only be connected to public and private fire hydrants that have a confirmed capability to provide adequate water quantities and pressures to supply the designed water supply needs for an automatic sprinkler or standpipe system.

It might be necessary to alter the pressure of 150 psi (10.3 bar) to properly supply foam-water sprinkler systems, hydraulically calculated sprinkler systems, or high-rise systems. Performance of certain systems, such as foam-water sprinkler systems or hydraulically calculated sprinkler systems, can be adversely affected by increased pressures beyond the design limits of the system.

The 150 psi (10.3 bar) is a starting point for the initial connection. The working pressure of sprinkler system aboveground components is a minimum 175 psi (12.1 bar) and will have been hydrostatically tested at a minimum of 200 psi (14 bar). The pump operator should look for a sign at the fire department connection indicating the required pressure. For a sprinkler system, the purpose of the fire department connection is to only supplement the pressure. On combination systems (sprinkler system and standpipe system), a sign is required to indicate the required pressure for the standpipe system, which in many situations will far exceed 150 psi (10.3 bar).

Submitter Information Verification

Submitter Full Name: Robert Fash

Organization: National Fire Protection Assoc

Street Address:

City:

State:

Zip:

Submittal Date: Wed Mar 21 09:08:12 EDT 2018

Committee Statement

Committee Statement: The Committee understands that the 150 PSI guidance works well for sprinkler systems. However, many times there will be a combination system. In that situation, the 150 PSI may not be enough pressure to supply the standpipe demand.

Response Message:

[Public Input No. 5-NFPA 13E-2016 \[Section No. A.4.3.4\]](#)



First Revision No. 15-NFPA 13E-2018 [Section No. C.1.1]

C.1.1 NFPA Publications.

National Fire Protection Association, 1 Batterymarch Park, Quincy, MA 02169-7471.

NFPA 13, *Standard for the Installation of Sprinkler Systems*, 2013 2019 edition.

NFPA 14, *Standard for the Installation of Standpipe and Hose Systems*, 2013 2019 edition.

NFPA 20, *Standard for the Installation of Stationary Pumps for Fire Protection*, 2013 2019 edition.

NFPA 901, *Standard Classifications for Incident Reporting and Fire Protection Data*, 2011 2020 edition.

NFPA 909, *Code for the Protection of Cultural Resource Properties — Museums, Libraries, and Places of Worship*, 2017 edition.

NFPA 1142, *Standard on Water Supplies for Suburban and Rural Fire Fighting*, 2012 2017 edition.

Submitter Information Verification

Submitter Full Name: Robert Fash

Organization: National Fire Protection Assoc

Street Address:

City:

State:

Zip:

Submittal Date: Tue Apr 03 11:29:31 EDT 2018

Committee Statement

Committee Statement: NFPA Publications updated

Response Message:



First Revision No. 22-NFPA 13E-2018 [Section No. C.3]

C.3 References for Extracts in Informational Sections. (Reserved)

NFPA 13 . *Standard for the Installation of Sprinkler Systems* , 2019 edition.

NFPA 25 . *Standard for the Inspection, Testing, and Maintenance of Water-Based Fire Protection Systems* , 2020 edition.

Submitter Information Verification

Submitter Full Name: Jeremy Souza

Organization: National Fire Protection Assoc

Street Address:

City:

State:

Zip:

Submittal Date: Thu May 03 10:50:04 EDT 2018

Committee Statement

Committee Statement: References updated to reflect new documents used in Annex.

Response Message: